

# **FSV100 and FSV200 Series**

## **General Purpose Solenoid Valves**

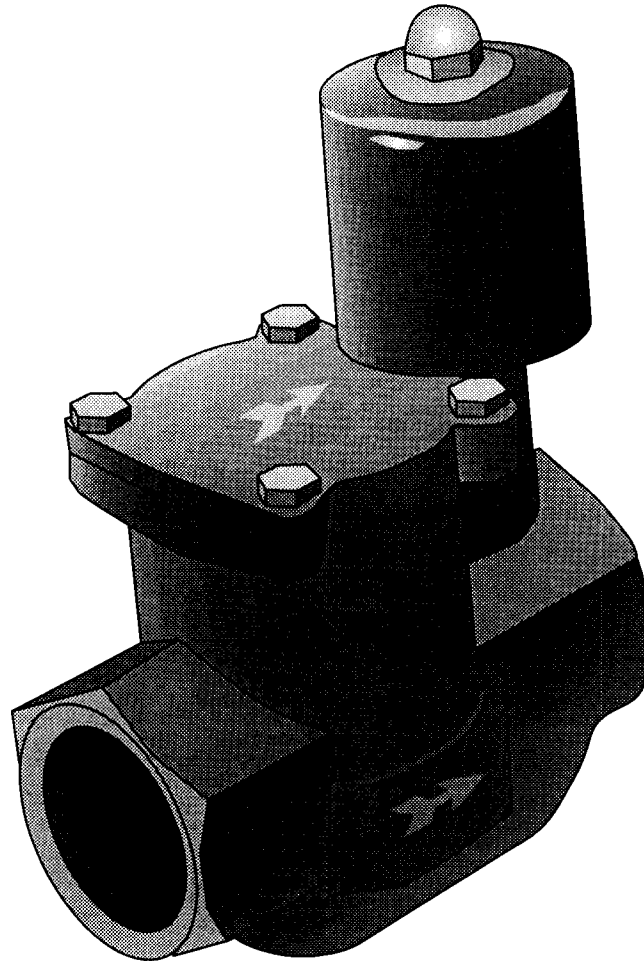

**Operator's Manual**



## Servicing USA and Canada: Call OMEGA Toll Free

### USA

One Omega Drive, Box 4047  
Stamford, CT 06907-0047  
Telephone: (203) 359-1660  
FAX: (203) 359-7700

### Canada

976 Bergar  
Laval (Quebec) H7L 5A1  
Telephone: (514) 856-6928  
FAX: (514) 856-6886

Sales Service: 1-800-826-6342 / 1-800-TC-OMEGA<sup>SM</sup>  
Customer Service: 1-800-622-2378 / 1-800-622-BEST<sup>SM</sup>  
Engineering Service: 1-800-872-9436 / 1-800-USA-WHEN<sup>SM</sup>  
TELEX: 996404 EASYLINK: 62968934 CABLE OMEGA

## Servicing Europe: United Kingdom Sales and Distribution Center

25 Swannington Road, Broughton Astley, Leicestershire  
LE9 6TU, England  
Telephone: 44 (1455) 285520 FAX: 44 (1455) 283912

## The OMEGA Complete Measurement and Control Handbooks & Encyclopedias

- ✓ Temperature
- ✓ Pressure, Strain & Force
- ✓ Flow and Level
- ✓ pH and Conductivity
- ✓ Data Acquisition Systems
- ✓ Electric Heaters
- ✓ Environmental Monitoring and Control



Call for Your **FREE Handbook Request Form Today: (203) 359-RUSH**

**Table of Contents**  
**FSV100 / FSV200 Series**  
**General Purpose Solenoid Valve**

	<b>Page</b>
<b>Chapter 1 Introduction</b> .....	<b>1</b>
1.1 Unpacking .....	1
1.2 Description .....	1
1.3 Features .....	2
1.4 Available Models .....	2
1.5 Typical Applications.....	3
<b>Chapter 2 Parts of the Solenoid Valve</b> .....	<b>4</b>
<b>Chapter 3 Installation</b> .....	<b>4</b>
<b>Chapter 4 Troubleshooting Guide</b> .....	<b>5</b>
<b>Chapter 5 Spare Parts List</b> .....	<b>6</b>
<b>Chapter 6 Specifications</b> .....	<b>7</b>

## Notes

# Chapter 1 Introduction

## 1.1 Unpacking

Remove the Packing List and verify that you have received all equipment, including the following (quantities in parentheses):

General Purpose Solenoid Valve (1)

Operator's Manual (1)

If you have any questions about the shipment, please call OMEGA Customer Service Department. When you receive the shipment, inspect the container and equipment for signs of damage. Note any evidence of rough handling in transit. Immediately report any damage to the shipping agent.

### NOTE

The carrier will not honor any claims unless all shipping material is saved for inspection. After examining and removing contents, save packing material and carton in the event reshipment is necessary.

## 1.2 Description

The OMEGA® FSV100 and FSV200 Series Two-Way Normally Closed Pilot Operated Piston-Type Solenoid Valves cover most industrial applications. A two-way valve controls the flow of fluid through a single passage. It has two ports, an inlet and an outlet. A normally closed valve does not pass fluid unless it is energized. There is fail safe positive valve closing in the event of power failure that prevents flooding or overfilling.

These valves cover a wide range of operating pressures and temperatures. 5 PSI to 150 PSI pressure and temperatures to 195°F affords broad application and tremendous flexibility. The long life bronze castings and waterproof coils insure performance consistency for a long life. Since the valves are very rugged, they provide low incidence of down time and maintenance.

Minimum pressure drop internal design of this valve assures exceptional flow performance.

### 1.3 Features

The FSV100/FSV200 solenoid valves have the following features:

- 2-way Normally Closed
- Pilot-Operated
- Piston-Type
- Bronze Construction
- Variety of Voltages
- Maximum Temperature of 195°F
- Maximum Pressure 150 PSI

### 1.4 Available Models

OMEGA Engineering, Inc. has the following models with the following characteristics:

#### FSV100 Series for Water

Part Number *	Description
FSV101	Solenoid Valve with BUNA N/EPDM Seal and 3/8" NPT Connector
FSV102	Solenoid Valve with BUNA N/EPDM Seal and 1/2" NPT Connector
FSV103	Solenoid Valve with BUNA N/EPDM Seal and 3/4" NPT Connector
FSV104	Solenoid Valve with BUNA N/EPDM Seal and 1.00" NPT Connector
FSV105	Solenoid Valve with BUNA N/EPDM Seal and 1.25" NPT Connector
FSV106	Solenoid Valve with BUNA N/EPDM Seal and 1.50" NPT Connector
FSV107	Solenoid Valve with BUNA N/EPDM Seal and 2.00" NPT Connector

\* For DIN coil option, add suffix "-DIN" to the part number.

## FSV200 Series for Light Oils and Solvents

Part Number *	Description
FSV201	Solenoid Valve with Viton Seal and 3/8" NPT Connector
FSV202	Solenoid Valve with Viton Seal and 1/2" NPT Connector
FSV203	Solenoid Valve with Viton Seal and 3/4" NPT Connector
FSV204	Solenoid Valve with Viton Seal and 1.0" NPT Connector
FSV205	Solenoid Valve with Viton Seal and 1.25" NPT Connector
FSV206	Solenoid Valve with Viton Seal and 1.50" NPT Connector
FSV207	Solenoid Valve with Viton Seal and 2.00" NPT Connector

\* For DIN coil option, add suffix "- DIN" to the part number.

### 1.5 Typical Applications

- Commercial Laundry Equipment and Facilities
- Commercial Dishwashers, Bottlewashers, Pot/Pan Washers
- Car & Truck Wash Facilities
- Irrigation Systems
- Humidification
- Water Treatment
- Poultry Incubators/Watering Equipment
- Industrial Maintenance, Repair, and Operation

## Chapter 2 Parts of the Solenoid Valve

### FSV100/200 Series

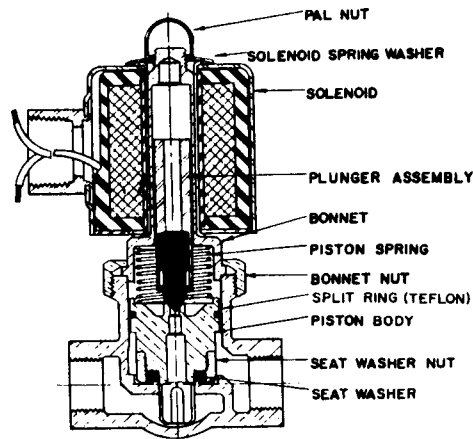

Figure 2-1. 3/8", 1/2", 3/4" NPT

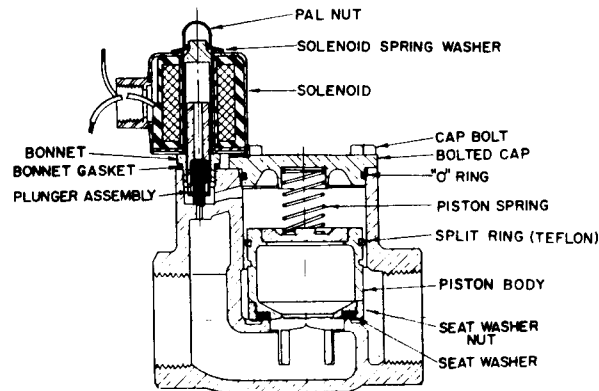

Figure 2-2. 1", 1 1/4", 1 1/2", 2" NPT

## Chapter 3 Installation

Be sure to adhere to the following when installing your solenoid valve:

- Arrow on valve body indicates direction of flow.
- Apply wrench only on end of valve being connected; (leverage on other valve parts can cause damage)
- Install in horizontal position with solenoid vertical.
- Make electrical connections in compliance with electrical code.

### CAUTION

Be certain electric power is of the same voltage and cycles as marked on solenoid.



## Chapter 4 Troubleshooting Guide

Problem	Possible Cause	Corrective Action
Failure to open when solenoid energized	1. Low voltage at solenoid (below 85% of rated voltage)	Insure proper voltage at solenoid
	2. Solenoid failure	Check for excessive voltage at solenoid
	3. Worn rings	Replace split rings
	4. Pressure drop less than 5 PSI	Increase pressure differential to 5 PSI
	5. Bonnet bent	Install new bonnet
	6. Should have approximately 1/16" gap in split piston rings.	Trim as required
Failure to close when solenoid de-energized	1. Piston Ring binding between body bore and piston	Remove piston and place ring in groove, then insert piston in body
	2. Foreign matter lodged on body seat	Remove piston and clean out matter
	3. Foreign matter preventing plunger from seating	Clean out foreign matter at plunger seat hole
	4. Plunger tip is broken or badly worn	Replace plunger assembly
Leakage	1. Plunger seat hole eroded	3/8", 1/2", & 3/4" replace piston  1", 1-1/4", 1-1/2", & 2" replace valve
	2. Piston seat washer takes a deep set	Replace seat washer

Caution: Do not apply voltage to solenoid coil that has been removed from valve.

## Chapter 5 Spare Parts List

Solenoid Electrical Data	Volts	Spare Part Number	Max. Watts Holding	Max. Volt Amps		Duty
				In Rush	Holding	
Coil with 1/2" NPT Conduit outlet and 30" lead wires. Fits all valve sizes.	24 Vac	7373209	19	72	39	Continuous
	120 Vac	7367909	23	77	46	Continuous
	208 Vac	7373309	20	75	42	Continuous
	240 Vac	7373109	22	77	46	Continuous
	480 Vac	7459909	18	62	34	Continuous

Consult Factory for other voltages and coils with ground wire.

### 3/8"•1/2"•3/4"•1"•1¼"•1½"•2" NPT Connector Styles

FSV100					
	3/8" & 1/2"	3/4"	1" & 1¼"	1½"	2"
Plunger Assembly	7319503	7319503	7319503	7319503	7319503
Bonnet	83021	73026	83192	83192	83192
Bonnet Gasket	N/A	N/A	82224	82224	82224
Bonnet Nut	76303	76028	N/A	N/A	N/A
Bolted Cap	N/A	N/A	76744	7674701	7668801
"O" Ring	N/A	N/A	87407	85321	85799
Cap Bolt	N/A	N/A	84552	88234	85459
Pal Nut	83069	83069	83069	83069	83069
Solenoid Spring Washer	83600	83600	83600	83600	83600
Piston Spring	82486	82488	82486	82486	82486
Piston Assembly	7735501	77300	7643101	7646901	7647001
Teflon Split Piston Ring (2 Req'd)	8502901	8503002	8503102	86549	86550
Piston Seat Washer	8222301	8249801	84048	84571	84518
Piston Seat Washer Nut	82222	86030	76745	76750	7673801

FSV200					
Same Parts as FSV100 Except Following Parts of Viton:					
	3/8" & 1/2"	3/4"	1" & 1¼"	1½"	2"
Plunger Assembly	74777	74777	74777	74777	74777
"O" Ring	N/A	N/A	87408	85649	85650
Piston Assembly	7735504	7730002	7643103	7646902	7647002
Piston Seat Washer	84689	84688	84794	85614	85612

# Chapter 6 Specifications

## FSV100/FSV200 Series

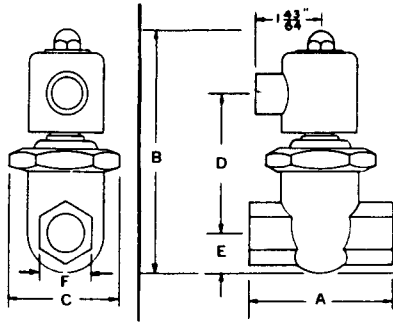

Figure 6-1. 3/8", 1/2", & 3/4"

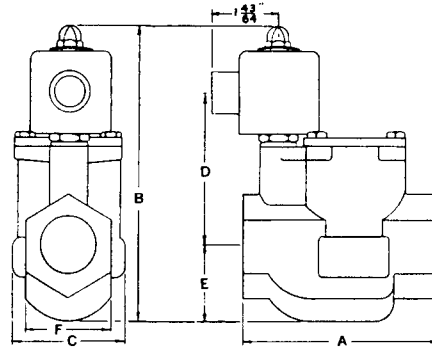

Figure 6-2. 1", 1 1/4", 1 1/2", & 2"

FSV100: For fluids compatible with bronze, 430 F Stainless Steel, Ethylene Propylene, and Teflon  
 FSV200: For fluids compatible with bronze, 430 F Stainless Steel, Viton, and Teflon

Pipe Size (Valve Size)						
Dimension	3/8"	1/2"	3/4"	1 & 1/4"	1 1/2"	2"
A	2-17/32"	2-21/32"	3-3/4"	4-13/16"	5-7/16"	6-1/32"
B	5-1/16"	5-1/16"	6-1/32"	6-31/32"	7-11/32"	8-3/16"
C	1-55/64"	1-55/64"	2-13/16"	2-3/4"	3-1/8"	3-3/4"
D	2-27/32"	2-27/32"	3-1/2"	3-5/8"	4-5/16"	4-21/32"
E	11/16"	11/16"	1"	1-3/4"	1-1/2"	1-15/16"
F	15/16"	1-3/32"	1-3/8"	2-1/16"	2-3/8"	2-7/8"

Pipe Size	3/8"	1/2"	3/4"	1"	1-1/4"	1-1/2"	2"
Cv Factor	2.3	3.3	7.5	9.8	15	28	39

Note: (Cv Factor) The amount of water that will flow through the valve with a 1 PSI pressure drop at 60 F. This should be used for a comparison flow.

Weight	3/8"	1/2"	3/4"	1"	1-1/4"	1-1/2"	2"
Lbs.	2.00	2.12	3.50	7.20	7.25	10.00	13.75
Kgs.	0.91	0.96	1.59	3.27	3.29	4.55	6.25

Maximum Viscosity:	17.8 Centistokes
Minimum Pressure:	5 PSI
Maximum Pressure:	150 PSI
Temperature Range:	32°F to 195° (0°C to 90°C)
Medium:	Water (FSV100): Oil/and Solvents (FSV200)
Power:	23 Watts, 120 Vac coils
Wetted Parts:	Bronze, Teflon, EPDM (FSV200 Series - Viton)
Cv Values:	Refer to flow Capacity Charts
Dimensions:	Refer to above figures
Weight:	Refer to above table

# Specifications (con't)

## Flow Capacity Charts

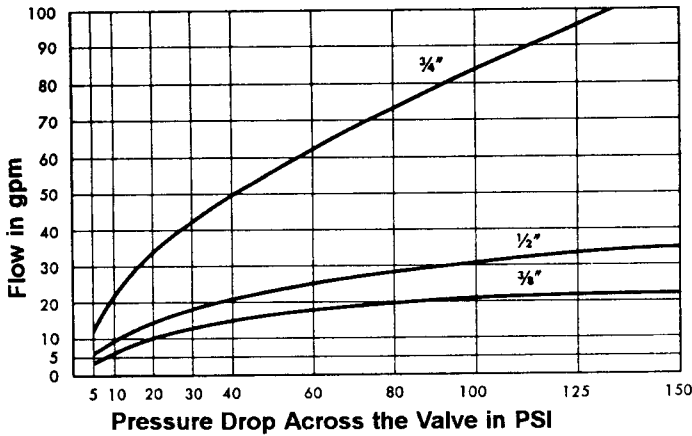

Figure 6-3. 3/8", 1/2", 3/4" NPT

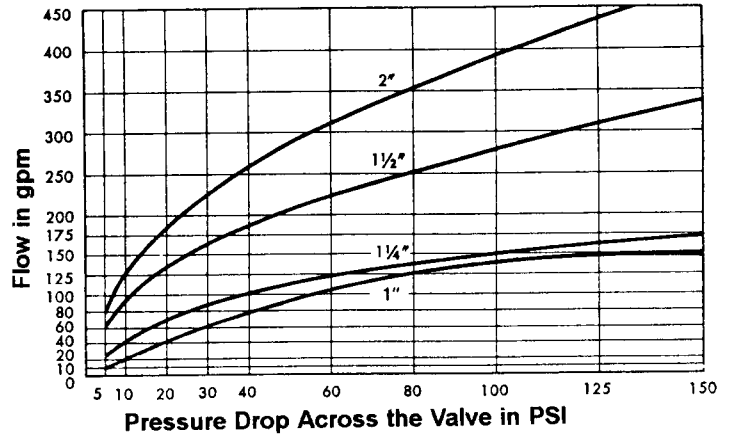

Figure 6-4. 1", 1 1/4", 1 1/2", 2" NPT

- \* Valves require minimum 5 PSI pressure differential for reliable operation.
- \* Must be installed in horizontal piping with solenoid in vertical position.
- \* Valve should be sized to flow requirement, not pipe size.
- \* Average closing time: 3/8"-3/4" 1-3 sec., 1"-2" 2-5 sec.

Part Number	NPT	Orifice	Seal	Response Time (Sec)		Tolerance
				Open	Close	
<b>FSV100 Series for Water</b>						
FSV101	3/8	0.439	BunaN/EPDM	0.85	0.015	±0.001
FSV102	1/2	0.439	BunaN/EPDM	0.85	0.015	±0.001
FSV103	3/4	0.849	BunaN/EPDM	0.6-4.5	0.1-0.25	±0.005
FSV104	1.00	1.250	BunaN/EPDM	0.6-4.5	0.1-0.25	±0.002
FSV105	1.25	1.250	BunaN/EPDM	0.8-5.8	0.2-0.5	±0.002
FSV106	1.50	1.500	BunaN/EPDM	1.5-9	0.2-0.4	±0.002
FSV107	2.00	2.000	BunaN/EPDM	1.5-9.5	0.25-0.45	±0.002
<b>FSV200 Series for Light Oils and Solvents, Max. Viscosity: 17.8 Ck.</b>						
FSV201	3/8	0.439	Viton	0.85	0.015	±0.001
FSV202	1/2	0.439	Viton	0.85	0.015	±0.001
FSV203	3/4	0.849	Viton	0.6-4.5	0.1-0.25	±0.005
FSV204	1.00	1.250	Viton	0.6-4.5	0.1-0.25	±0.002
FSV205	1.25	1.250	Viton	0.8-5.8	0.2-0.5	±0.002
FSV206	1.50	1.500	Viton	1.5-9	0.2-0.4	±0.002
FSV207	2.00	2.000	Viton	1.5-9.5	0.25-0.45	±0.002

## Notes

## Notes



## WARRANTY

OMEGA warrants this unit to be free of defects in materials and workmanship and to give satisfactory service for a period of **13 months** from date of purchase. OMEGA Warranty adds an additional one (1) month grace period to the normal **one (1) year product warranty** to cover handling and shipping time. This ensures that OMEGA's customers receive maximum coverage on each product. If the unit should malfunction, it must be returned to the factory for evaluation. OMEGA's Customer Service Department will issue an Authorized Return (AR) number immediately upon phone or written request. Upon examination by OMEGA, if the unit is found to be defective it will be repaired or replaced at no charge. However, this WARRANTY is VOID if the unit shows evidence of having been tampered with or shows evidence of being damaged as a result of excessive corrosion; or current, heat, moisture or vibration; improper specification; misapplication; misuse or other operating conditions outside of OMEGA's control. Components which wear or which are damaged by misuse are not warranted. These include contact points, fuses, and triacs.

**OMEGA is glad to offer suggestions on the use of its various products. Nevertheless, OMEGA only warrants that the parts manufactured by it will be as specified and free of defects.**

**OMEGA MAKES NO OTHER WARRANTIES OR REPRESENTATIONS OF ANY KIND WHATSOEVER, EXPRESSED OR IMPLIED, EXCEPT THAT OF TITLE AND ALL IMPLIED WARRANTIES INCLUDING ANY WARRANTY OF MERCHANTABILITY AND FITNESS FOR A PARTICULAR PURPOSE ARE HEREBY DISCLAIMED.**

**LIMITATION OF LIABILITY: The remedies of purchaser set forth herein are exclusive and the total liability of OMEGA with respect to this order, whether based on contract, warranty, negligence, indemnification, strict liability or otherwise, shall not exceed the purchase price of the component upon which liability is based. In no event shall OMEGA be liable for consequential, incidental or special damages.**

Every precaution for accuracy has been taken in the preparation of this manual; however, OMEGA ENGINEERING, INC. neither assumes responsibility for any omissions or errors that may appear nor assumes liability for any damages that result from the use of the products in accordance with the information contained in the manual.

**SPECIAL CONDITION:** Should this equipment be used in or with any nuclear installation or activity, purchaser will indemnify OMEGA and hold OMEGA harmless from any liability or damage whatsoever arising out of the use of the equipment in such a manner.

## RETURN REQUESTS / INQUIRIES

Direct all warranty and repair requests/inquiries to the OMEGA ENGINEERING Customer Service Department. BEFORE RETURNING ANY PRODUCT(S) TO OMEGA, PURCHASER MUST OBTAIN AN AUTHORIZED RETURN (AR) NUMBER FROM OMEGA'S CUSTOMER SERVICE DEPARTMENT (IN ORDER TO AVOID PROCESSING DELAYS). The assigned AR number should then be marked on the outside of the return package and on any correspondence.

FOR **WARRANTY** RETURNS, please have the following information available BEFORE contacting OMEGA:

1. P.O. number under which the product was PURCHASED,
2. Model and serial number of the product under warranty, and
3. Repair instructions and/or specific problems relative to the product.

FOR **NON-WARRANTY** REPAIRS OR **CALIBRATION**, consult OMEGA for current repair/calibration charges. Have the following information available BEFORE contacting OMEGA:

1. P.O. number to cover the COST of the repair/calibration,
2. Model and serial number of product, and
3. Repair instructions and/or specific problems relative to the product.

OMEGA's policy is to make running changes, not model changes, whenever an improvement is possible. This affords our customers the latest in technology and engineering.

OMEGA is a registered trademark of OMEGA ENGINEERING, INC.

© Copyright 1994 OMEGA ENGINEERING, INC. All rights reserved. This documentation may not be copied, photocopied, reproduced, translated, or reduced to any electronic medium or machine-readable form, in whole or in part, without prior written consent of OMEGA ENGINEERING, INC.

# Where Do I Find Everything I Need for Process Measurement and Control? OMEGA...Of Course!

## **TEMPERATURE**

- Thermocouple, RTD & Thermistor Probes, Connectors, Panels & Assemblies
- Wire: Thermocouple, RTD & Thermistor
- Calibrators & Ice Point References
- Recorders, Controllers & Process Monitors
- Infrared Pyrometers

## **PRESSURE/STRAIN FORCE**

- Transducers & Strain Gages
- Load Cells & Pressure Gauges
- Displacement Transducers
- Instrumentation & Accessories

## **FLOW/LEVEL**

- Rotameters, Gas Mass Flowmeters & Flow Computers
- Air Velocity Indicators
- Turbine/Paddlewheel Systems
- Totalizers & Batch Controllers

## **pH/CONDUCTIVITY**

- pH Electrodes, Testers & Accessories
- Benchtop/Laboratory Meters
- Controllers, Calibrators, Simulators & Pumps
- Industrial pH & Conductivity Equipment

## **DATA ACQUISITION**

- Data Acquisition and Engineering Software
- Communications-Based Acquisition Systems
- Plug-in Cards for Apple, IBM & Compatibles
- Datalogging Systems
- Recorders, Printers & Plotters

## **HEATERS**

- Heating Cable
- Cartridge & Strip Heaters
- Immersion & Band Heaters
- Flexible Heaters
- Laboratory Heaters

## **ENVIRONMENTAL MONITORING AND CONTROL**

- Metering & Control Instrumentation
- Refractometers
- Pumps & Tubing
- Air, Soil & Water Monitors
- Industrial Water & Wastewater Treatment
- pH, Conductivity & Dissolved Oxygen Instruments