

**Hamilton Beach®**

# *Electric Griddle*

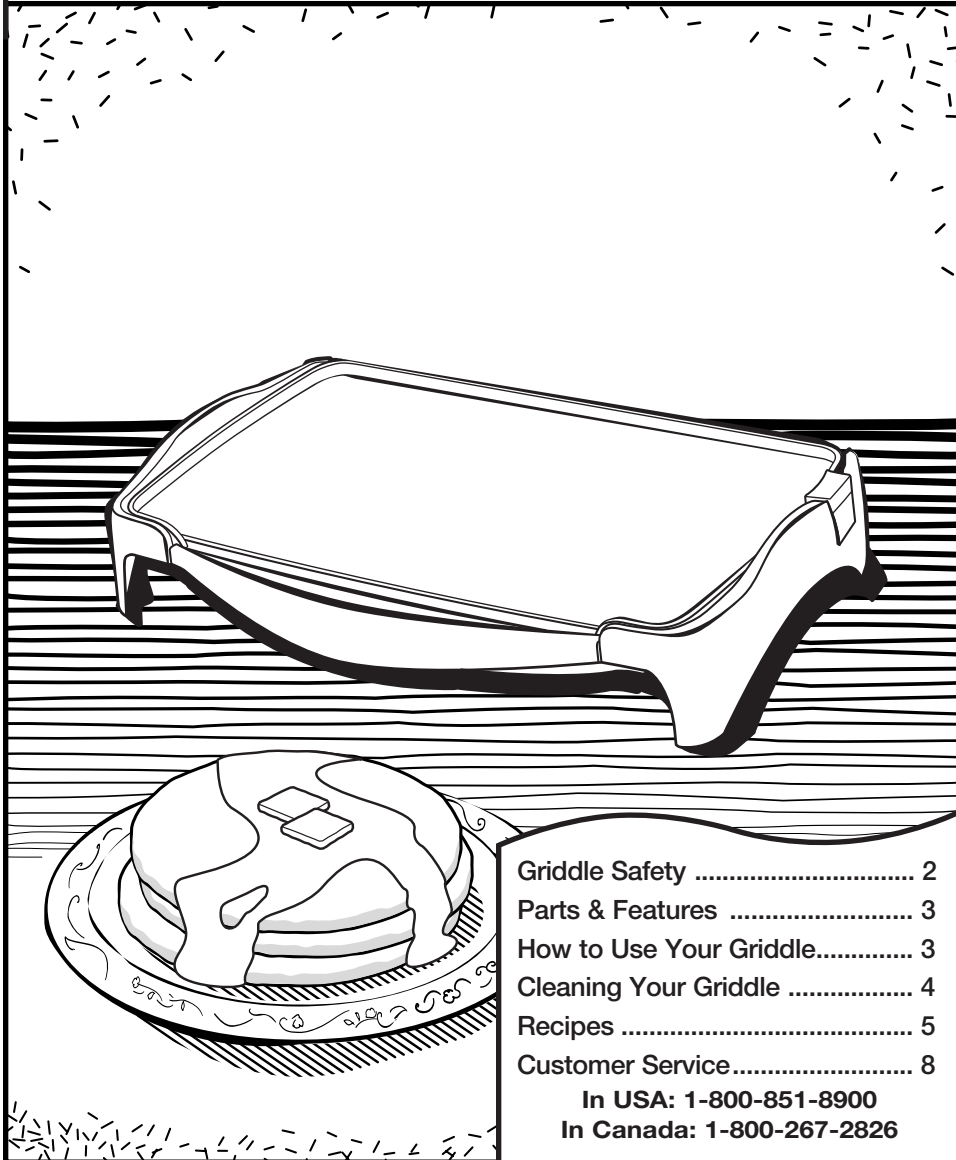

Griddle Safety .....	2
Parts & Features .....	3
How to Use Your Griddle.....	3
Cleaning Your Griddle .....	4
Recipes .....	5
Customer Service.....	8

**In USA: 1-800-851-8900**  
**In Canada: 1-800-267-2826**

840098400

# Griddle Safety

## IMPORTANT SAFEGUARDS

When using electrical appliances, basic safety precautions should always be followed, including the following:

1. Read all instructions.
2. Do not touch hot surfaces. Use handles or knobs, which may be warm. Use oven mitts.
3. To protect against electric shock, do not immerse cord, plug, or variable heat power cord in water or other liquid.
4. Close supervision is necessary when any appliance is used by or near children.
5. Unplug from outlet when not in use and before cleaning. Allow to cool before putting on or taking off parts, and before cleaning the appliance.
6. Do not operate any appliance with a damaged cord or plug, or after the appliance malfunctions, or has been dropped or damaged in any manner. Call our toll-free customer service number for examination, repair, or adjustment.
7. The use of accessory attachments not recommended by Hamilton Beach/Proctor-Silex may cause injuries.
8. Do not use outdoors.
9. Do not let cord hang over edge of table or counter, or touch hot surfaces, including the stove.
10. Do not place on or near a hot gas or electric burner, or in a heated oven.
11. Extreme caution must be used when moving an appliance containing hot oil or other hot liquids.
12. Always attach plug to appliance first, then plug cord into the wall outlet. To disconnect, turn any control to "MIN" then remove plug from wall outlet.
13. Use only the power cord provided with this appliance.
14. Do not use appliance for other than intended use.

## SAVE THESE INSTRUCTIONS!

### Consumer Safety Information

To avoid an electrical circuit overload, do not operate another high wattage appliance on the same circuit with the griddle.

This appliance is equipped with a grounded-type 3-wire cord (3-prong plug). This type of plug will only fit into an electrical outlet made for a 3-prong plug. This is a safety feature intended to help reduce the risk of electrical shock. If the plug should fail to fit contact a qualified electrician to replace the obsolete outlet. Do not attempt to defeat the safety purpose of the grounding pin, by modifying the plug in any way.

The length of the cord used on this appliance was selected to reduce the hazards of becoming tangled in, or tripping over a longer cord. If a longer cord is necessary an approved extension cord may be used. The electrical rating of the extension cord must be equal to or greater than the rating of the electric griddle and be a grounded 3-wire cord. Care must be taken to arrange the extension cord so that it will not drape over the countertop or tabletop where it can be pulled on by children or accidentally tripped over.

**Before First Use:** Wash griddle in hot, soapy water. Rinse thoroughly and dry. The griddle may also be washed in a dishwasher.

# Parts & Features

1. Nonstick Griddle
2. Variable Heat Power Cord
3. Drip Tray

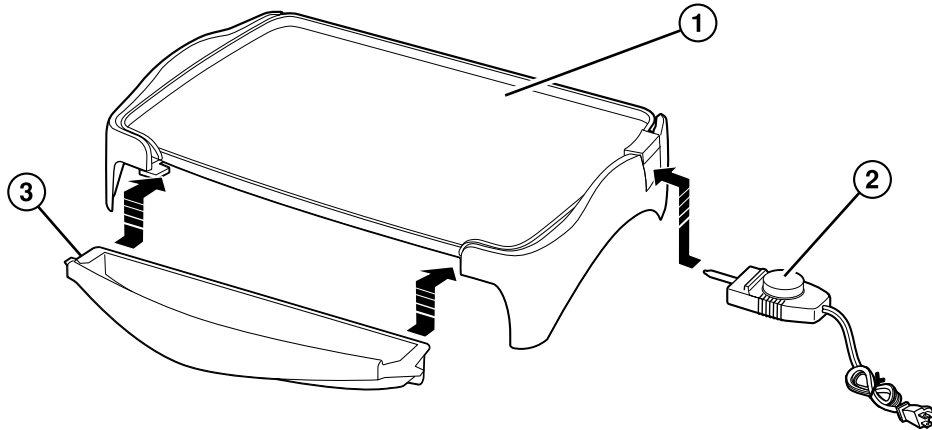

## How to Use Your Griddle

1. Always use griddle on a dry, level, heat-resistant surface.
2. Make sure drip tray is in place.
3. Set power cord control to MIN. Plug power cord into griddle.
4. Plug cord into electrical outlet.
5. Refer to the Cooking Chart for selecting the correct heat setting.
6. Preheat griddle 5 to 10 minutes until desired temperature is reached.
7. When the indicator light on the variable heat power cord goes out, the cooking temperature has been reached. You may now add the food.
8. When finished cooking, remove food, turn temperature control to MIN, and unplug unit.

### NOTES:

- For best results, space foods evenly on the griddle and do not overload the griddle.
- Only use wooden or plastic cooking utensils to prolong the life of the nonstick coating.
- Do not place any pot, pan, or dish on the nonstick griddle surface.

## Cooking Chart

Food	Temperature	Time
Fried Eggs	325°F	2 to 3 minutes
French Toast	350°F	8 to 10 minutes
Grilled Cheese Sandwiches	375°F	4 to 5 minutes
Pancakes	375°F	4 to 5 minutes
Hamburgers (1/3 lb. each)	350°F	15 to 20 minutes
Bacon	350°F	10 to 15 minutes
Sausage Links and Patties	350°F	15 minutes
Hot Dogs	325°F	15 minutes

## *Cleaning Your Griddle*

1. When finished cooking, turn variable heat power cord control to MIN and unplug from outlet.
2. Let griddle cool completely. Remove power cord. Remove drip tray by lifting up and then pulling out.
3. Clean griddle and drip tray with hot, soapy water, using a plastic or nylon scouring pad. Rinse then dry. Or place the griddle and drip tray in automatic dishwasher.

4. Clean variable heat power cord with a damp cloth.

**Do not use metal scouring pads or abrasive cleansers. This will damage the nonstick coating.**

**⚠WARNING: To reduce the risk of shock, do not immerse Variable Heat Power Cord in water or other liquid.**

# Recipes

## *Pancake Basics!*

- Since pancake batter does not need a lot of mixing, over-mixing is a frequent mistake. The dry ingredients and wet ingredients should be stirred together until just mixed. A few lumps will remain. If your batter looks too thick you may add more liquid. Using the liquid that is called for in the recipe, add only one tablespoon at a time until the batter reaches desired consistency.
- A properly preheated griddle is also very important to perfect pancakes. So don't skip the preheating.
- Once you have poured batter onto the griddle, the pancakes should only be turned once. When the top of the pancake is covered with bubbles it is ready to be turned. The second side will not take as long to cook as the first.

## **Your Favorite Pancakes**

---

Make one batch of basic pancakes from your favorite scratch recipe or a boxed mix. Preheat griddle according to directions. Pour batter by  $\frac{1}{4}$  cupfuls onto the griddle. Sprinkle with one of the following mix-ins then turn and cook until done. Use the suggested topping or regular syrup.

### **Mix-Ins:**

Mini-Chocolate Chips  
Chopped Pecans  
Chopped Peanuts  
Chopped Bananas  
Cooked, Crumbled Bacon

### **Toppings:**

Whipped Topping  
Maple Syrup  
Warmed Grape Jelly  
Strawberry Preserves  
Scrambled Eggs

## **Pancakes**

---

1 cup flour	1 egg
2 teaspoons baking powder	1 cup milk
$\frac{1}{2}$ teaspoon salt	3 tablespoons butter, melted
2 tablespoons sugar	

Preheat griddle to 375°F. Combine all ingredients in a bowl until just mixed. Using  $\frac{1}{4}$  cup per pancake, pour batter onto griddle. Cook approximately 4 to 5 minutes turning once. **Makes 10 pancakes.**

## Buttermilk Pancakes

---

2 cups all purpose flour	½ teaspoon salt
3 tablespoons sugar	2 cups buttermilk
1 tablespoon baking powder	3 eggs

Preheat griddle to 375°F. Stir together flour, sugar, baking powder and salt in large bowl to blend. Combine buttermilk and eggs to blend. Add to dry ingredients and stir until mixed. Pour batter by ¼ cupfuls onto griddle. Cook about 3 to 4 minutes turning once. **Makes 20-22 pancakes.**

## Overnight Raisin Oatmeal Pancakes

---

2 cups quick cooking oats	2 tablespoons sugar
2½ cups milk	1 teaspoon baking powder
2 eggs	1 teaspoon baking soda
¼ cup vegetable oil	½ teaspoon ground cinnamon
½ cup flour	½ teaspoon salt
	⅓ cup raisins

Mix together the oatmeal, milk, eggs and oil. Mix together the flour, sugar, baking powder, baking soda, cinnamon and salt. Add to oatmeal mixture and stir to mix. Cover and refrigerate overnight. The next morning, stir in raisins. Allow batter to sit for 10 minutes before cooking. Preheat griddle to 375°F. Pour batter by ¼ cupfuls onto griddle. Cook about 5 minutes turning once. **Makes 16-18 pancakes.**

## Apple-Molasses Pancakes

---

1½ cups milk	2 cups flour
2 tart apples such as Granny Smith, peeled, cored, and cut in large chunks	1½ teaspoons baking powder
1 egg	¼ teaspoon baking soda
4 tablespoons butter, melted	¼ teaspoon salt
2 tablespoons molasses	¼ teaspoon cinnamon

Preheat griddle to 325°F. Place milk, apple chunks, egg, butter and molasses in blender jar.\* Pulse or blend briefly (3 to 5 seconds) until apples are finely chopped. In a large bowl, combine flour, baking powder, baking soda, salt and cinnamon. Stir the dry ingredients to mix. Add apple/milk mixture and stir until just combined. Batter will be thick but still pourable. Pour batter by ¼ cupfuls onto griddle. Cook for 3 to 4 minutes then turn pancakes and cook about 2 to 3 minutes more.

**Makes 16-18 pancakes.**

\*If you do not have a blender, finely shred apples using a grater.

## Peanut Butter and Jelly Pancakes

---

1 cup flour	½ cup peanut butter
1 tablespoon sugar	1 egg
2 teaspoons baking powder	1 tablespoon oil
½ teaspoon salt	Jelly or preserves
1¼ cups milk	

Preheat griddle to 350°F. Combine flour, sugar, baking powder, and salt. In a separate bowl combine milk, peanut butter, egg, and oil. Stir until combined, then add to dry ingredients. Pour batter by ¼ cupfuls onto griddle. Cook about 5 minutes turning once. Serve with jelly or preserves. **Makes 14-16 pancakes.**

## Blueberry Pancakes

---

2½ cups flour	1 tablespoon vegetable oil
1 teaspoon salt	2 eggs
1 tablespoon baking powder	2 cups milk
2 tablespoons sugar	1½ cups frozen blueberries; thawed, rinsed, and dried on paper towel

Preheat griddle to 375°F. In a large bowl, mix together flour, salt, baking powder and sugar. In a small bowl, beat together oil, eggs and milk. Stir into flour mixture. Fold in the blueberries. Pour batter by ¼ cupfuls onto griddle. Cook about 5 minutes turning once. **Makes 20-24 pancakes.**

## French Toast

---

1 tablespoon butter, melted	½ teaspoon vanilla
4 eggs	¼ teaspoon cinnamon
½ teaspoon salt	8 slices of bread
1 cup milk	

Preheat griddle to 350°F. Mix eggs, butter, salt, milk, vanilla, and cinnamon in a large bowl. One at a time, dip slices of bread in the egg mixture to coat thoroughly on both sides. Place bread onto the griddle and fry until golden brown, about 5 minutes per side. **Makes 8 slices.**

## Campers' Egg & Cinnamon Toast

---

4 slices bread	1 teaspoon cinnamon
Softened butter or margarine	4 eggs
1 tablespoon sugar	Salt and pepper

Preheat griddle to 325°F. Lightly butter both sides of bread slices. Cut or tear a 3-inch hole in the center of each bread slice. (Hole must be big enough so most of egg touches griddle. Save the centers; do not discard. In a small bowl combine sugar and cinnamon. Sprinkle both sides of bread slices and centers with the cinnamon-sugar. Place bread and centers on griddle and cook for about 2 minutes. Flip all bread and centers over. Break one egg into each of the 4 holes. Season with salt & pepper. Cook for about 4 minutes or to desired doneness. Flip again if desired. Serve with the extra bread center sitting atop the egg. **Makes 4 servings.**

## Johnnycakes

---

1½ cups stone-ground cornmeal	1 teaspoon sugar
1 teaspoon salt	2½ cups boiling water

Preheat griddle to 325°F. Combine the cornmeal, salt and sugar in a large bowl. Stirring constantly, slowly add the boiling water to the bowl. Set batter aside for 10 minutes. The batter should be thick but not stiff. Scoop ¼ cup batter onto griddle. The cakes should be thick (about ¾ inch) and no more than 3 inches across. Cook until the underside is a deep golden brown, 6 to 11 minutes. Turn the cakes over and continue to cook for another 6 to 11 minutes. **Makes about 10 cakes.**

# Customer Service

Call our toll-free customer service numbers. Please note the model, type, and series number on the variable heat power cord, or have the griddle close by when you call. This will help us answer your questions.

## LIMITED WARRANTY

This product is warranted to be free from defects in material and workmanship for a period of two (2) years for Hamilton Beach Portfolio products or one (1) year for Hamilton Beach products from the date of original purchase, except as noted below. During this period, we will repair or replace this product, at our option, at no cost. THE FOREGOING WARRANTY IS IN LIEU OF ANY OTHER WARRANTY, WHETHER EXPRESS OR IMPLIED, WRITTEN OR ORAL INCLUDING ANY WARRANTY OF MERCHANTABILITY OR FITNESS FOR A PARTICULAR PURPOSE. ANY LIABILITY IS EXPRESSLY LIMITED TO AN AMOUNT EQUAL TO THE PURCHASE PRICE PAID, AND ALL CLAIMS FOR SPECIAL, INCIDENTAL AND CONSEQUENTIAL DAMAGES ARE HEREBY EXCLUDED. There is no warranty with respect to the following, which may be supplied with this product: glass parts, glass containers, cutter/strainer, blades, and/or agitators. This warranty extends only to the original consumer purchaser and does not cover a defect resulting from abuse, misuse, neglect, use for commercial purposes, or any use not in conformity with the printed directions. This warranty gives you specific legal rights, and you may also have other legal rights which vary from state to state, or province to province. Some states or provinces do not allow limitations on implied warranties or special, incidental or consequential damages, so the foregoing limitations may not apply to you.

If you have a claim under this warranty, DO NOT RETURN THE APPLIANCE TO THE STORE! Please call our CUSTOMER SERVICE NUMBER. (For faster service please have model, series, and type numbers ready for operator to assist you.)

## CUSTOMER SERVICE NUMBERS

In the U.S. 1-800-851-8900

In Canada 1-800-267-2826

Web site address: [www.hamiltonbeach.com](http://www.hamiltonbeach.com)

**KEEP THESE NUMBERS FOR FUTURE REFERENCE!**

HAMILTON BEACH ♦ PROCTOR-SILEX, INC.

263 Yadkin Road  
Southern Pines, North Carolina 28387

840098400

Web site address: [www.hamiltonbeach.com](http://www.hamiltonbeach.com)

PROCTOR-SILEX CANADA, INC.

Picton, Ontario K0K 2T0

3/02