

Grizzly **Industrial, Inc.**®

MODEL T25100 POWDER COATING SYSTEM OWNER'S MANUAL *(For models manufactured since 8/12)*



COPYRIGHT © DECEMBER, 2012 BY GRIZZLY INDUSTRIAL, INC. REVISED SEPTEMBER, 2013 (TR)
**WARNING: NO PORTION OF THIS MANUAL MAY BE REPRODUCED IN ANY SHAPE
OR FORM WITHOUT THE WRITTEN APPROVAL OF GRIZZLY INDUSTRIAL, INC.**
#TS15269 PRINTED IN CHINA



WARNING!

This manual provides critical safety instructions on the proper setup, operation, maintenance, and service of this machine/tool. Save this document, refer to it often, and use it to instruct other operators.

Failure to read, understand and follow the instructions in this manual may result in fire or serious personal injury—including amputation, electrocution, or death.

The owner of this machine/tool is solely responsible for its safe use. This responsibility includes but is not limited to proper installation in a safe environment, personnel training and usage authorization, proper inspection and maintenance, manual availability and comprehension, application of safety devices, cutting/sanding/grinding tool integrity, and the usage of personal protective equipment.

The manufacturer will not be held liable for injury or property damage from negligence, improper training, machine modifications or misuse.



WARNING!

Some dust created by power sanding, sawing, grinding, drilling, and other construction activities contains chemicals known to the State of California to cause cancer, birth defects or other reproductive harm. Some examples of these chemicals are:

- **Lead from lead-based paints.**
- **Crystalline silica from bricks, cement and other masonry products.**
- **Arsenic and chromium from chemically-treated lumber.**

Your risk from these exposures varies, depending on how often you do this type of work. To reduce your exposure to these chemicals: Work in a well ventilated area, and work with approved safety equipment, such as those dust masks that are specially designed to filter out microscopic particles.

Table of Contents

- INTRODUCTION..... 2**
 - Tool Description 2
 - Contact Info 2
 - Manual Accuracy..... 2
 - Identification 3
 - Specifications 3

- SECTION 1: SAFETY 4**
 - Safety Instructions for Machinery 4
 - Additional Safety for Powder Coating Systems 6

- SECTION 2: POWER SUPPLY 7**
 - Availability..... 7
 - 120V Circuit Requirements 7
 - Grounding & Plug Requirements 8
 - Extension Cords 8

- SECTION 3: SETUP 9**
 - Unpacking 9
 - Inventory..... 9
 - Site Considerations 10
 - Space Allocation..... 10
 - Physical Environment..... 10
 - Ventilation..... 10
 - Electrical Installation..... 10
 - Lighting..... 10
 - Moisture Filter Installation 10

- SECTION 4: OPERATIONS 11**
 - Operation Overview..... 11
 - Basic Controls & Components 12
 - Operational Points..... 13
 - Workpiece Preparation..... 14
 - Scatter Tips 14
 - Powder Cups..... 15
 - Curing..... 15

- SECTION 5: ACCESSORIES 16**

- SECTION 6: MAINTENANCE..... 17**
 - Schedule 17
 - Cleaning 17

- SECTION 7: SERVICE 18**
 - Troubleshooting..... 18

- SECTION 8: PARTS..... 20**

- WARRANTY & RETURNS 21**

INTRODUCTION

Tool Description

Powder coating with the Model T25100 is a superior alternative finishing process to wet painting on metal parts. A few of the advantages of powder coating are high durability, high-impact and stress resistance, and uniform control of finish.

The powder coating process uses a dry, finely-ground polymer of various types and mixtures that is electrically charged and applied onto the metal workpiece through electrical attraction. After completing the powder application, the finish must be cured (baked) in a dedicated electric oven.

Contact Info

We stand behind our machines. If you have any questions or need help, use the information below to contact us. Before contacting, please get the serial number and manufacture date of your machine. This will help us help you faster.

Grizzly Technical Support
1203 Lycoming Mall Circle
Muncy, PA 17756
Phone: (570) 546-9663
Email: techsupport@grizzly.com

We want your feedback on this manual. What did you like about it? Where could it be improved? Please take a few minutes to give us feedback.

Grizzly Documentation Manager
P.O. Box 2069
Bellingham, WA 98227-2069
Email: manuals@grizzly.com

Manual Accuracy

We are proud to provide a high-quality owner's manual with your new tool!

We made every effort to be exact with the instructions, specifications, drawings, and photographs contained inside. Sometimes we make mistakes, but our policy of continuous improvement also means that **sometimes the tool you receive will be slightly different than what is shown in the manual.**

If you find this to be the case, and the difference between the manual and tool leaves you confused about a procedure, check our website for an updated version. We post current manuals and manual updates for free on our website at **www.grizzly.com**.

Alternatively, you can call our Technical Support for help. Before calling, please write down the **Manufacture Date** and **Serial Number** stamped into the machine ID label (see below). This information helps us determine if updated documentation is available for your tool.

		MODEL GXXXX MACHINE NAME	
SPECIFICATIONS		▲ WARNING!	
Motor:		To reduce risk of serious injury when using this machine:	
Specification:		1. Read manual before operation.	
Specification:		2. Wear safety glasses and respirator.	
Specification:		3. Make sure machine is properly adjusted/setup and	
Specification:		4. Make sure the motor has stopped and disconnect	
Weight:		5. DO NOT expose to rain or dampness.	
		6. DO NOT modify this machine in any way.	
		7.	
		8.	
		9. Do not use while under the influence of drugs or alcohol.	
		10. Maintain machine carefully to prevent accidents.	

Manufactured for Grizzly in Taiwan

Manufacture Date []

Serial Number []



Identification

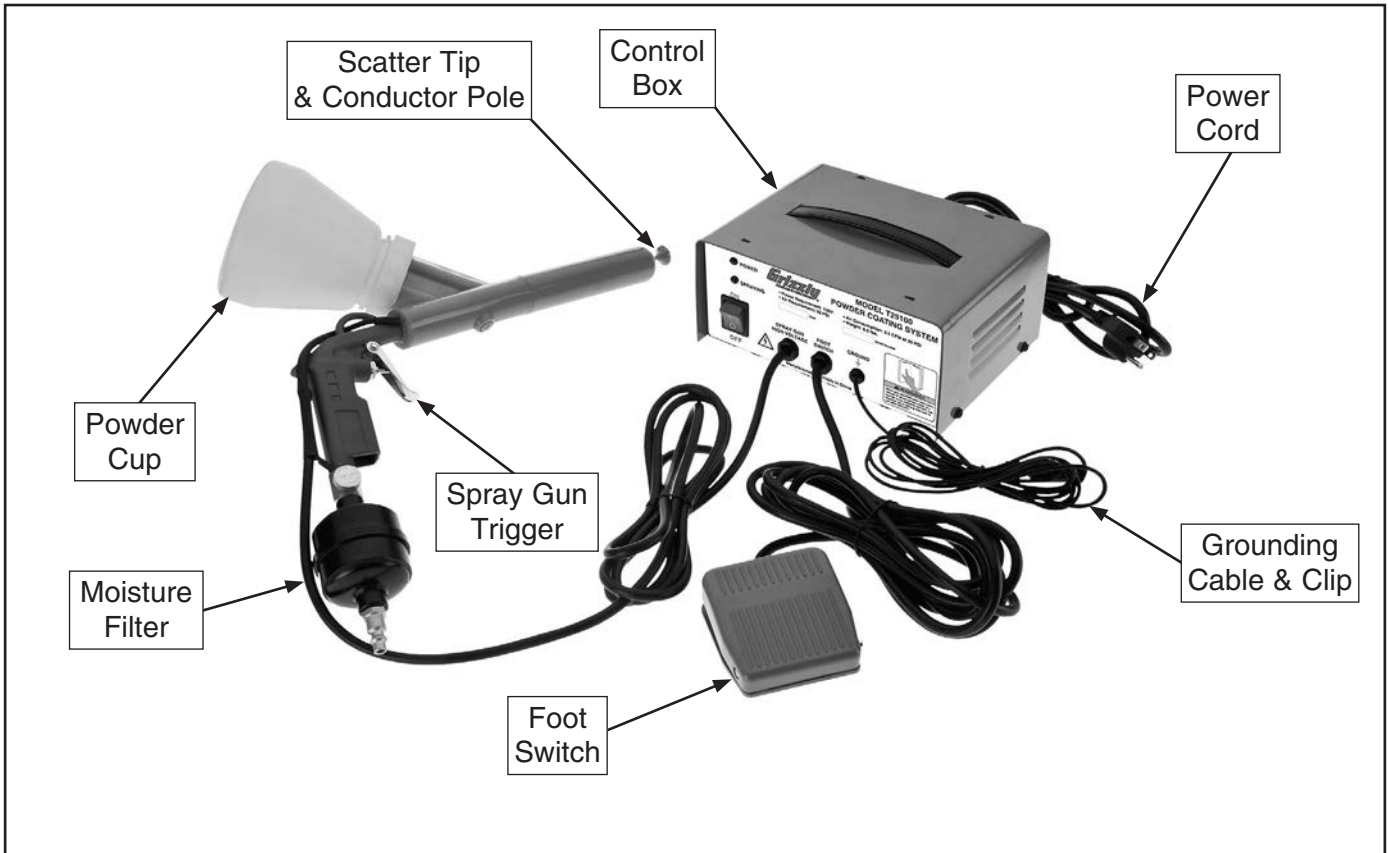

Specifications

Power Requirement.....	120V, 15A
Recommended Air Supply	10–30 PSI
Maximum Air Supply	30 PSI
Air Consumption.....	3.5 CFM at 30 PSI
Output Voltage.....	10kv–13kv
Air Quick-Connect Size	1/4" NPT
Powder Coating Gun Cord Length	8 ft.
Grounding Cable Length	8 ft.
Foot Pedal Cord Length	10 ft.
Power Cord Length.....	6 ft.
Included Plug.....	NEMA 5-15
Weight	6.5 lbs.

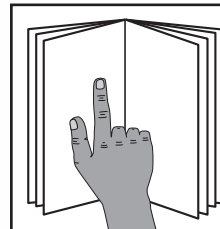

! WARNING

To reduce your risk of serious injury, read this entire manual **BEFORE** using machine.



SECTION 1: SAFETY

For Your Own Safety, Read Instruction Manual Before Operating This Machine

The purpose of safety symbols is to attract your attention to possible hazardous conditions. This manual uses a series of symbols and signal words intended to convey the level of importance of the safety messages. The progression of symbols is described below. Remember that safety messages by themselves do not eliminate danger and are not a substitute for proper accident prevention measures. Always use common sense and good judgment.

 **DANGER** Indicates an imminently hazardous situation which, if not avoided, **WILL** result in death or serious injury.

 **WARNING** Indicates a potentially hazardous situation which, if not avoided, **COULD** result in death or serious injury.

 **CAUTION** Indicates a potentially hazardous situation which, if not avoided, **MAY** result in minor or moderate injury. It may also be used to alert against unsafe practices.

NOTICE This symbol is used to alert the user to useful information about proper operation of the machine.

Safety Instructions for Machinery

WARNING

OWNER'S MANUAL. Read and understand this owner's manual **BEFORE** using machine.

TRAINED OPERATORS ONLY. Untrained operators have a higher risk of being hurt or killed. Only allow trained/supervised people to use this machine. When machine is not being used, disconnect power, remove switch keys, or lock-out machine to prevent unauthorized use—especially around children. Make workshop kid proof!

DANGEROUS ENVIRONMENTS. Do not use machinery in areas that are wet, cluttered, or have poor lighting. Operating machinery in these areas greatly increases the risk of accidents and injury.

MENTAL ALERTNESS REQUIRED. Full mental alertness is required for safe operation of machinery. Never operate under the influence of drugs or alcohol, when tired, or when distracted.

ELECTRICAL EQUIPMENT INJURY RISKS. You can be shocked, burned, or killed by touching live electrical components or improperly grounded machinery. To reduce this risk, only allow qualified service personnel to do electrical installation or repair work, and always disconnect power before accessing or exposing electrical equipment.

DISCONNECT POWER FIRST. Always disconnect machine from power supply **BEFORE** making adjustments, changing tooling, or servicing machine. This prevents an injury risk from unintended startup or contact with live electrical components.

EYE PROTECTION. Always wear ANSI-approved safety glasses or a face shield when operating or observing machinery to reduce the risk of eye injury or blindness from flying particles. Everyday eyeglasses are **NOT** approved safety glasses.



WARNING

WEARING PROPER APPAREL. Do not wear clothing, apparel or jewelry that can become entangled in moving parts. Always tie back or cover long hair. Wear non-slip footwear to avoid accidental slips, which could cause loss of workpiece control.

HAZARDOUS DUST. Dust created while using machinery may cause cancer, birth defects, or long-term respiratory damage. Be aware of dust hazards associated with each workpiece material, and always wear a NIOSH-approved respirator to reduce your risk.

HEARING PROTECTION. Always wear hearing protection when operating or observing loud machinery. Extended exposure to this noise without hearing protection can cause permanent hearing loss.

REMOVE ADJUSTING TOOLS. Tools left on machinery can become dangerous projectiles upon startup. Never leave chuck keys, wrenches, or any other tools on machine. Always verify removal before starting!

USE CORRECT TOOL FOR THE JOB. Only use this tool for its intended purpose—do not force it or an attachment to do a job for which it was not designed. Never make unapproved modifications—modifying tool or using it differently than intended may result in malfunction or mechanical failure that can lead to personal injury or death!

AWKWARD POSITIONS. Keep proper footing and balance at all times when operating machine. Do not overreach! Avoid awkward hand positions that make workpiece control difficult or increase the risk of accidental injury.

CHILDREN & BYSTANDERS. Keep children and bystanders at a safe distance from the work area. Stop using machine if they become a distraction.

GUARDS & COVERS. Guards and covers reduce accidental contact with moving parts or flying debris. Make sure they are properly installed, undamaged, and working correctly.

FORCING MACHINERY. Do not force machine. It will do the job safer and better at the rate for which it was designed.

NEVER STAND ON MACHINE. Serious injury may occur if machine is tipped or if the cutting tool is unintentionally contacted.

STABLE MACHINE. Unexpected movement during operation greatly increases risk of injury or loss of control. Before starting, verify machine is stable and mobile base (if used) is locked.

USE RECOMMENDED ACCESSORIES. Consult this owner's manual or the manufacturer for recommended accessories. Using improper accessories will increase the risk of serious injury.

UNATTENDED OPERATION. To reduce the risk of accidental injury, turn machine **OFF** and ensure all moving parts completely stop before walking away. Never leave machine running while unattended.

MAINTAIN WITH CARE. Follow all maintenance instructions and lubrication schedules to keep machine in good working condition. A machine that is improperly maintained could malfunction, leading to serious personal injury or death.

CHECK DAMAGED PARTS. Regularly inspect machine for any condition that may affect safe operation. Immediately repair or replace damaged or mis-adjusted parts before operating machine.

MAINTAIN POWER CORDS. When disconnecting cord-connected machines from power, grab and pull the plug—NOT the cord. Pulling the cord may damage the wires inside. Do not handle cord/plug with wet hands. Avoid cord damage by keeping it away from heated surfaces, high traffic areas, harsh chemicals, and wet/damp locations.

EXPERIENCING DIFFICULTIES. If at any time you experience difficulties performing the intended operation, stop using the machine! Contact our Technical Support at (570) 546-9663.



WARNING

Additional Safety for Powder Coating Systems

ELECTROSTATIC GROUNDING. The powder coating system electrically charges the powder and gun during application. To prevent electrical shock or dust explosion from electrostatic sparks, make sure that the power circuit, control box, and workpiece are well grounded. Make sure your body is well grounded to an earth ground, not the powder coating system—use a grounding strap if standing on non-grounded or insulated surface.

PERSONAL HEALTH. Powder used in this tool can cause eye, lung, and skin injuries with sustained exposure. Always wear ANSI-approved goggles/face mask, NIOSH-approved respirator, non-insulating gloves, and anti-static clothing that will protect your skin when handling the powder and during application.

DUST EXPLOSION. The finely-ground powder is flammable when floating in the air. Stay at least 50 feet away from any ignition source (e.g., open flame, hot water heater, welder, etc.) when handling the powder or during operation. Keep a multi-class fire extinguisher in the immediate work area.

AIR PRESSURE. Using air pressure with this tool that exceeds 30 PSI could cause the spray gun to break apart, which could result in impact injury or explosion. Never exceed 30 PSI of air pressure during operation.

ELECTRIC SHOCK. To avoid electrical shock when tool is connected to power, never touch conductor pole that protrudes from the gun nose—the conductor pole is electrically charged! After turning the control box **OFF**, touch the conductor pole to the grounding clip to discharge current. **NEVER** touch the metal workpiece during operation—it is also electrically charged! Do not use tool if you have electronic medical devices (e.g., pacemaker).

CURING FUMES. The fumes produced during curing can cause severe eye, lung, and skin injuries. Always make sure the oven is well-ventilated. Always wear ANSI approved goggles/face mask, respirator, and clothing that will protect your skin when exposed to curing fumes. **DO NOT** use a gas oven that could cause the fumes to explode—only use an electric oven. **DO NOT** use an oven that will be used for cooking food. Always keep the oven at least 50 feet away from any ignition source during the curing process—the fumes are volatile!

CAUTION

No list of safety guidelines can be complete. Every shop environment is different. Always consider safety first, as it applies to your individual working conditions. Use this and other equipment with caution and respect. Failure to do so could result in serious personal injury, damage to equipment, or poor work results.

WARNING

Like all equipment there is potential danger when operating this tool. Accidents are frequently caused by lack of familiarity or failure to pay attention. Use this tool with respect and caution to decrease the risk of operator injury. If normal safety precautions are overlooked or ignored, serious personal injury may occur.



SECTION 2: POWER SUPPLY

Availability

Before using the Model T25100, consider the availability and proximity of the required power supply circuit. If an existing circuit does not meet the requirements for this tool, a new circuit must be installed. To minimize the risk of electrocution, fire, or tool damage, installation work and electrical wiring must be done by an electrician or qualified service personnel in accordance with all applicable codes and standards.

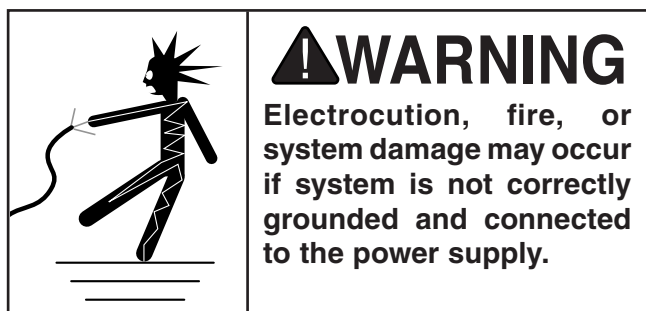

120V Circuit Requirements

This tool is prewired to operate on a power supply circuit that has a verified ground and meets the following requirements:

Nominal Voltage 120V
Cycle 60 Hz
Phase Single-Phase
Power Supply Circuit 15 Amps

A power supply circuit includes all electrical systems between the breaker box or fuse panel in the building and the T25100 control box. The power supply circuit used for this tool must be sized to safely handle the current drawn from the tool for an extended period of time. (If this machine is connected to a circuit protected by fuses, use a time delay fuse marked D.)

Note: *The circuit requirements listed in this manual apply to a dedicated circuit—where only one tool or machine will be running at a time. If this tool will be connected to a shared circuit where multiple tools or machines will be running at the same time, consult a qualified electrician to ensure that the circuit is properly sized for safe operation.*



Grounding & Plug Requirements

This system **MUST** be grounded. In the event of certain malfunctions or breakdowns, grounding reduces the risk of electric shock by providing a path of least resistance for electric current.

This system is equipped with a power cord that has an equipment-grounding wire and a grounding plug (similar to the figure below). The plug must only be inserted into a matching receptacle (outlet) that is properly installed and grounded in accordance with all local codes and ordinances.

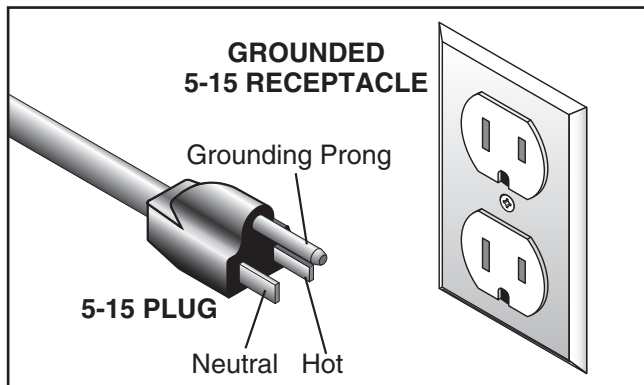

Figure 1. Typical 5-15 plug and receptacle.

⚠ CAUTION

SHOCK HAZARD!

Two-prong outlets do not meet the grounding requirements for this machine. Do not modify or use an adapter on the plug provided—if it will not fit the outlet, have a qualified electrician install the proper outlet with a verified ground.

Improper connection of the equipment-grounding wire can result in a risk of electric shock. The wire with green insulation (with or without yellow stripes) is the equipment-grounding wire. If repair or replacement of the power cord or plug is necessary, do not connect the equipment-grounding wire to a live (current carrying) terminal.

Check with a qualified electrician or service personnel if you do not understand these grounding requirements, or if you are in doubt about whether the tool is properly grounded. If you ever notice that a cord or plug is damaged or worn, disconnect it from power, and immediately replace it with a new one.

Extension Cords

We do not recommend using an extension cord with this tool. If you must use an extension cord, only use it if absolutely necessary and only on a temporary basis.

Extension cords cause voltage drop, which may damage electrical components and shorten tool life. Voltage drop increases as the extension cord size gets longer and the gauge size gets smaller (higher gauge numbers indicate smaller sizes).

Any extension cord used with this tool must contain a ground wire, match the required plug and receptacle, and meet the following requirements:

Minimum Gauge Size 16 AWG
Maximum Length (Shorter is Better).....50 ft.



SECTION 3: SETUP

Unpacking

Your machine was carefully packaged for safe transportation. Remove the packaging materials from around your machine and inspect it. If you discover any damage, *please call us immediately at (570) 546-9663 for advice.*

Save the containers and all packing materials for possible inspection by the carrier or its agent. *Otherwise, filing a freight claim can be difficult.*

When you are completely satisfied with the condition of your shipment, inventory the contents.

	<p>!WARNING SUFFOCATION HAZARD! Keep children and pets away from plastic bags or packing materials shipped with this machine. Discard immediately.</p>
--	--

Inventory

The following is a list of items shipped with your machine. Before beginning setup, lay these items out and inventory them.

If any non-proprietary parts are missing (e.g. a nut or a washer), we will gladly replace them; or for the sake of expediency, replacements can be obtained at your local hardware store.

<p>NOTICE If you cannot find an item on this list, carefully check around/inside the machine and packaging materials. Often, these items get lost in packaging materials while unpacking or they are pre-installed at the factory.</p>
--

Box Inventory (Figures 2–3):	Qty
A. Powder Coating System.....	1
B. Powder Cups w/Gaskets & Lids.....	2
C. Moisture Filter.....	1
D. Powder Flow Regulator Screw O-Ring	1
E. Fuse 0.5A, Fast-Acting.....	1
F. Scatter Tip 1/2"	1
G. Scatter Tip 3/4".....	1
H. Scatter Tip 1".....	1



Figure 2. Powder coating system.

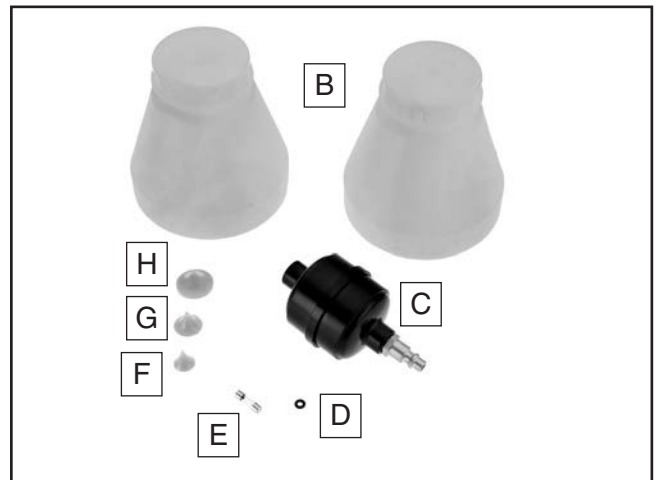

Figure 3. Small item inventory.



Site Considerations

Space Allocation

Consider the largest size of workpiece that will be processed with the powder coating system. Provide enough space for adequate operator material handling or the installation of auxiliary equipment.

Physical Environment

The physical environment where this tool is operated is important for safe operation and longevity of the tool components. For best results, operate the powder coating system in a clean, dry environment that is free from excessive moisture, hazardous chemicals, airborne abrasives, or extreme conditions. Make sure that all flammable sources (e.g., open flame, hot water heater, welder, etc.) are at least 50 feet away from the work area.

Ventilation

The powder coating and curing processes produce hazardous dust or fumes that can cause long-term eye, lung, or skin injuries. Make sure the work area is well ventilated with either mechanical means or adequate exposure to outside air.

Electrical Installation

Operate this tool near an existing power source. Make sure all power cords are protected from traffic, material handling, moisture, chemicals, or other hazards. Make sure to leave access to a means of disconnecting the power source or engaging a lockout/tagout device, if required.

Lighting

Lighting around the work area must be adequate enough that operations can be performed safely. Shadows, glare, or strobe effect that may distract or impede the operator must be eliminated.

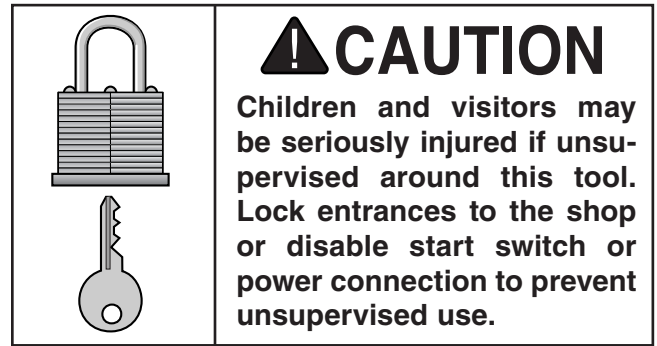

Moisture Filter Installation

Thread the moisture filter onto the spray gun handle, as shown in **Figure 4**.



Figure 4. Moisture filter installed.



SECTION 4: OPERATIONS

Operation Overview

The purpose of this overview is to provide the novice operator with a basic understanding of how the tool is used during operation, so the tool controls/components discussed later in this manual are easier to understand.

Due to the generic nature of this overview, it is not intended to be an instructional guide. To learn more about specific operations, read this entire manual and seek additional training from experienced operators, and do additional research outside of this manual by reading "how to" books, trade magazines, or websites.

	<p>!WARNING To reduce your risk of serious injury, read this entire manual BEFORE using this tool.</p>
--	--

<p>!WARNING Eye injuries, respiratory problems, or skin damage can occur while operating this tool. Wear approved safety goggles, respirator, non-insulating gloves, and anti-static clothing to protect your skin.</p>
--

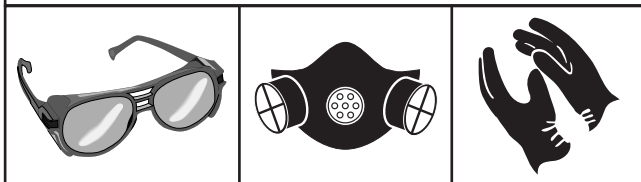

<p>NOTICE If you are not experienced with this type of equipment, WE STRONGLY RECOMMEND that you seek additional training outside of this manual. Read books/magazines or get formal training before beginning any projects. Regardless of the content in this section, Grizzly Industrial will not be held liable for accidents caused by lack of training.</p>
--

To complete a typical operation, the operator does the following:

1. Examines the metal workpiece to make sure it is dry, clean, and suitable for powder coating. Sandblasting the workpiece is one efficient method of cleaning it.
2. Places the workpiece on a stable surface or securely hangs it in a dry, clean, and well-ventilated area. If using a hanger, make sure that it is made of clean metal and makes good metal-to-metal contact with the workpiece.
3. Installs the proper scatter tip on the conductor pole.
4. Attaches the grounding clip to the workpiece or hanger with good metal-to-metal contact.
5. Puts on ANSI-approved goggles/face mask, respirator, and clothing that protects the operator's skin.
6. Fills the powder cup with approximately 2" of the selected powder.
7. Attaches the powder cup to the spray gun.
8. Connects the spray gun to a dry, clean, pressurized air source between 10 PSI and 30 PSI.
9. Connects the control box to power and turns the system **ON**.
10. Aims the spray gun at the workpiece, then simultaneously steps on the foot switch and pulls the gun trigger to direct the powder cloud onto the workpiece.
11. Maintain an even powder thickness of approximately 2mm.
12. When finished, turns the system **OFF**, and immediately grounds the conductor pole to the grounding clip to discharge the gun's electrical charge.



Basic Controls & Components

Use **Figures 5–7** and the following descriptions to gain a better understanding of the Model T25100 controls and components.

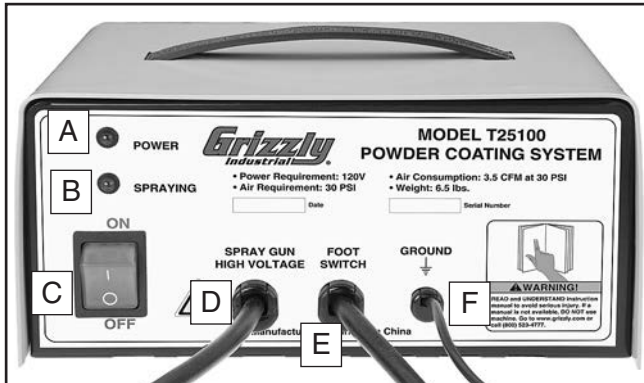

Figure 5. Control box panel.

- A. Power Lamp.** Illuminates when power is enabled to the control box.
- B. Spraying Lamp.** Illuminates when power is enabled to the spray gun.
- C. ON/OFF Switch.** Enables air power to the control box.
- D. Spray Gun Cable.** Connects the spray gun to the control box.
- E. Foot Switch Cable.** Connects the foot switch to the control box.
- F. Grounding Cable.** Provides an electrical ground for the workpiece.
- G. Air Quick-Connect.** Provides a 1/4" NPT connection for incoming air pressure.
- H. Moisture Filter.** A disposable unit that removes moisture from the incoming air. We recommend that you also use an additional in-line moisture filter on the air compressor.
- I. Air Pressure Regulating Valve.** Increases/decreases air flow to the spray gun.

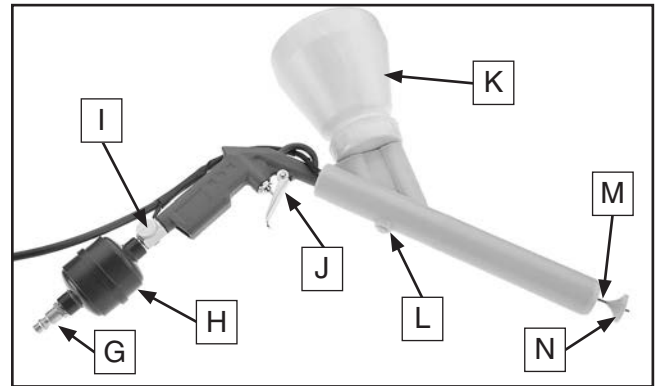

Figure 6. Spray gun controls.

- J. Spray Gun Trigger.** Enables air to flow through the powder cup and gun. To begin spraying, use the spray gun trigger and the foot switch simultaneously.
- K. Powder Cup.** Holds the powder coating material. Air is circulated inside the cup to provide a fine dust for spraying.
- L. Powder Flow Regulating Screw.** Fine tunes the flow of powder from the gun.
- M. Conductor Pole.** Electrically charges the powder dust as it leaves the spray gun.
- N. Scatter Tip.** Provides the spray pattern for the powder dust.

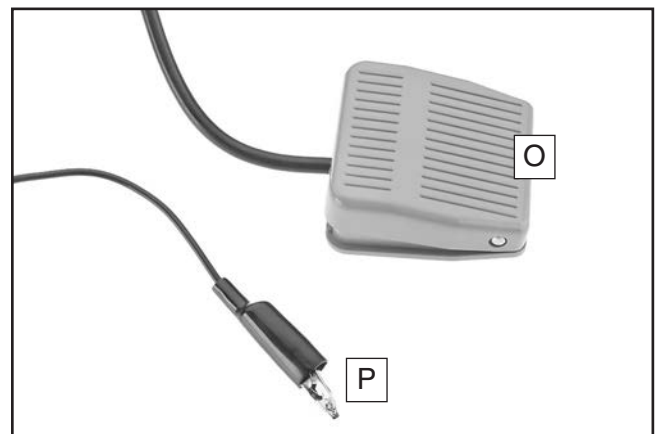

Figure 7. Foot switch and grounding clip.

- O. Foot Switch.** Enables power to the spray gun conductor pole. To begin spraying use the foot switch and the spray gun trigger simultaneously.
- P. Grounding Clip.** Provides an electrical ground for the workpiece.



Operational Points

Adhere to the following points for the best powder coating results:

- The workpiece **MUST** be clean of debris, paint, or other non-metal material. Depending upon the application, cleaning may be as simple as using mineral spirits and clean rags, or it may require a much more complicated "pre-treatment" process, such as sand-blasting.
- Obtaining good powder coating results depends on many variables—workpiece pre-treatment, powder chemical composition, method of spraying, curing procedure, etc. Read books, use online resources, or talk to professionals to gain an understanding what is required for your operation.
- Use only high-quality powder coatings. Investigate the many powder options on the market and choose the one that best suits your application.
- Use only pressurized air that is clean, dry, and free from oil.
- Make sure the system ground clip is firmly secured to the workpiece or hanger with good metal-to-metal contact.
- To begin spraying, depress the foot switch and spray gun trigger simultaneously. The foot switch enables power to the gun conductor pole, which electrically charges the dust as it leaves the gun. The spray gun trigger allows air to flow through the powder cup and gun to send the powder onto the workpiece.
- Use the air pressure regulating valve and powder flow regulating screw to control the flow of powder through the spray gun.
- Experiment with the scatter tips to gain an understanding of the effects attained with each tip.

- Use a side-to-side overlapping pattern when spraying. Most powder products require a coating of approximately 2mm. Check the powder manufacturer's specifications and practice attaining the correct thickness on a scrap workpiece.
- You **MUST** "cure" the workpiece to complete the powder coating process. The curing oven must have good ventilation. Poor air circulation can cause discoloration or hazing.

WARNING

Fumes from the curing process are poisonous! Make sure the curing oven is well-ventilated. Use a dedicated electric oven that will NOT be used for cooking food.

- Follow closely the powder manufacturer's directions for curing. Under-curing can result in poor physical qualities and over-curing can change the color.
- Always maintain clean powder cups, spray gun, and work area. Contamination of powder products by debris or other powder material can produce unexpected results.
- Some orange peel effect may be unavoidable. If this happens, wet-sand the workpiece with 400 grit sandpaper, thoroughly dry the workpiece, and repeat the coating process.
- To remove slight imperfections, buff the workpiece with a loose buffing wheel and white rouge compound.

	<h2> WARNING</h2> <p>Exposure to powder coating materials can cause eye, lung, or skin injury. Always wear ANSI-approved goggles, NIOSH-approved respirator, and wear clothing that will protect your skin.</p>
--	--



Workpiece Preparation

NOTICE

The powder coating system is designed to **ONLY** operate on solid, electrically-conductive metal workpieces.

Follow these workpiece preparation guidelines for the best results:

- Thoroughly clean the workpiece of paints or other finishes, residue left by cleaning solutions, debris, dust, and any other foreign material. Depending upon the application, additional pre-treatment steps may be necessary.
- Make sure the workpiece is completely dry.
- Attach the grounding clip (see **Figure 8**) to the workpiece or hanger with a good metal-to-metal contact at a point where the powder will not be applied. This will provide a negative electrical attraction for the charged power.



Figure 8. System grounding clip.

- Make sure the workpiece is not touching any other grounding source other than the powder coating system ground.
- To reduce the risk of electrical shock from workpiece contact, position or hang the workpiece so that it does not need to be re-positioned during the powder coating process.

- Use clean metal material for workpiece hangers. This will ensure that the hanger is grounded with the workpiece.

Scatter Tips

The Model T25100 ships with three scatter tips with diameters of 1/2", 3/4", and 1" (see **Figure 9**).

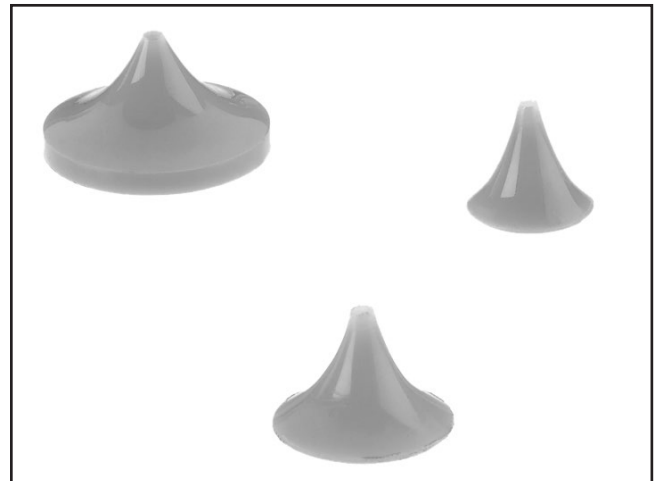

Figure 9. Included scatter tips.

The scatter tips thread onto the conductor pole (see **Figure 10**) and produce different spray patterns. Experiment with a scrap workpiece to gain an understanding of the effect that each tip produces.

Note: Wipe the tips clean of powder before storing them.

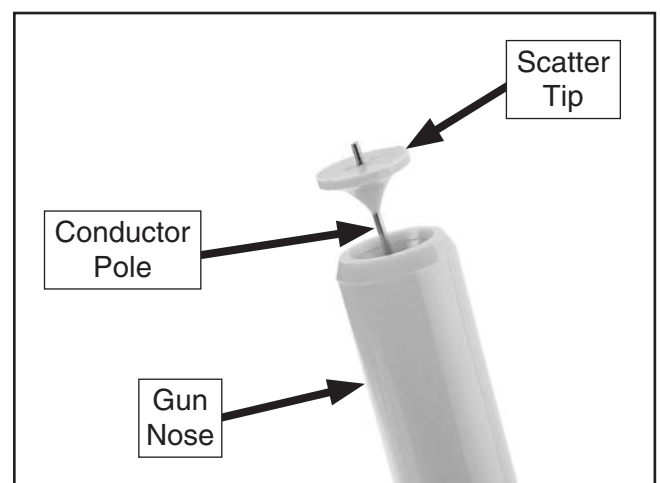



Figure 10. Scatter tip installed.





!WARNING
 The spray gun conductor pole may be electrically charged. Always disconnect the system from power and ground the conductor pole to the system grounding clip before making contact with conductor pole to reduce the risk of electric shock or dust explosion from electrostatic sparks.

Powder Cups

During operation, air circulates inside the powder cup to produce a fine dust, which is then fed through the spray gun and onto the workpiece.

To fill and attach the powder cup:

1. DISCONNECT TOOL FROM POWER!
2. Put on eye, lung, and skin protective gear.
3. Make sure the powder cup, gasket, and mounting cap components (see **Figure 11**) are dry and clean of any powder or debris.

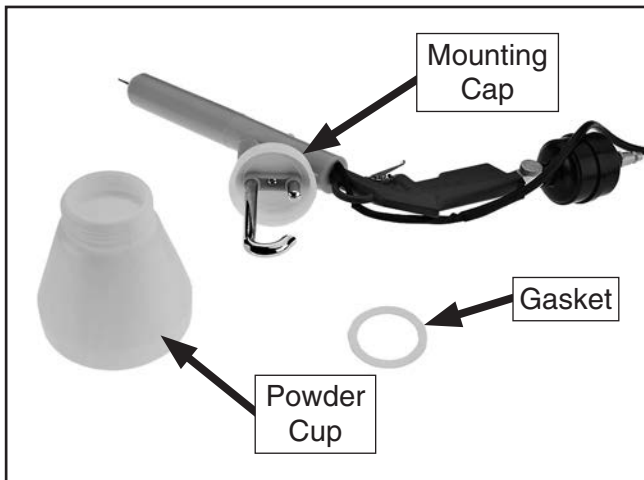

Figure 11. Powder cup components.

4. Insert the gasket into the mounting cap, then thread the empty powder cup onto the mounting cap.

5. Connect the tool to the air supply (but NOT to power) and use the spray gun trigger to send air through the gun to make sure any residual powder from the last operation is cleared away.

6. Remove the powder cup from the spray gun and fill it with up to 2" of powder.

Note: *Leaving space in the powder cup allows the powder to circulate into a fine dust when the air is applied.*

7. Make sure the gasket is in place inside the mounting cap, then turn the gun upside down and thread the powder cup onto the mounting cap (see **Figure 12**).



Figure 12. Powder cup installed.

Curing

Curing the powder coating is a process that melts the powder into an even finish that adheres to the workpiece. This is done with a dedicated electric oven that is not used for any other purpose.

Follow the powder coat manufacturer's recommendations for curing temperature and length of time to produce good results.

NOTICE

The powder coating will NOT adhere to the workpiece unless it is properly cured in a dedicated electric oven. Follow all recommendations made by the power coat manufacturer for properly curing their product.



SECTION 5: ACCESSORIES

!WARNING

Installing unapproved accessories may cause machine to malfunction, resulting in serious personal injury or machine damage. To reduce this risk, only install accessories recommended for this machine by Grizzly.

NOTICE

Refer to our website or latest catalog for additional recommended accessories.

- T20501—Face Shield Crown Protector 4"
- T20502—Face Shield Crown Protector 7"
- T20503—Face Shield Window
- T20452—"Kirova" Anti-Reflective S. Glasses
- T20451—"Kirova" Clear Safety Glasses
- H0736—Shop Fox® Safety Glasses
- H7194—Bifocal Safety Glasses 1.5
- H7195—Bifocal Safety Glasses 2.0
- H7196—Bifocal Safety Glasses 2.5



Figure 13. Eye protection assortment.

- H2499—Small Half-Mask Respirator
- H3631—Medium Half-Mask Respirator
- H3632—Large Half-Mask Respirator
- H3635—Cartridge Filter Pair P100

Fine chemical dust has been linked to nasal cancer and severe respiratory illnesses. If you work around dust everyday, a half-mask respirator can be a lifesaver. Also compatible with safety glasses!



Figure 14. Half-mask respirator with disposable cartridge filters.

H8118—Sandblasting Gun Kit

This spot sandblaster is the quickest, cleanest way to remove rust spots, peeling pain, or surface blemishes without disturbing the surrounding area. Supplied with 4 nozzles that allow you to spot blast inside corners, outside corner, edges, and flat areas for perfect surface preparation.

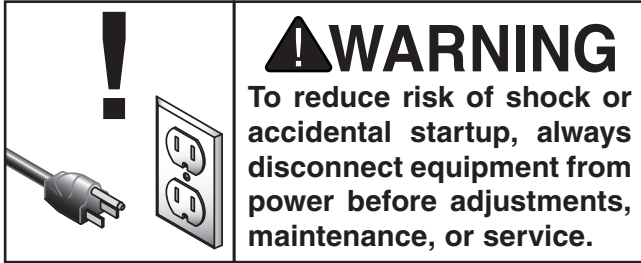

Figure 15. Model H8118 Sandblasting Gun Kit.

order online at www.grizzly.com or call 1-800-523-4777



SECTION 6: MAINTENANCE



Schedule

For optimum performance from your tool, follow this maintenance schedule and refer to any specific instructions given in this section.

Daily Check:

- Damaged spray gun components.
- Worn or damaged wires/cables.
- Any other unsafe condition.

Daily Maintenance:

- Clean the tool.
- Check/replace moisture filter.

Cleaning

Cleaning the Model T25100 is simple and straightforward.

To clean the Model T25100:

1. DISCONNECT TOOL FROM POWER!
2. DISCONNECT TOOL FROM AIR!
3. Ground the spray gun conductor pole to the grounding clip to remove any residual electrical charge.
4. Put on eye, lung, and skin protection.
5. Put uncontaminated powder back into the original container and store it in a dry, stable environment.
6. In a well-ventilated area, use compressed air to blow away the powder from the spray gun, powder cups, control box, and foot switch.



SECTION 7: SERVICE

Review the troubleshooting and procedures in this section if a problem develops with your machine. If you need replacement parts or additional help with a procedure, call our Technical Support at (570) 546-9663.

Note: Please gather the serial number and manufacture date of your machine before calling.

Troubleshooting

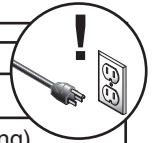

Symptom	Possible Cause	Possible Solution
Tool does not turn on.	<ol style="list-style-type: none"> Control box fuse is blown. Power source turned OFF at breaker. Wall fuse/circuit breaker is blown/tripped; short in electrical system. ON/OFF switch at fault. 	<ol style="list-style-type: none"> Replace control box fuse (0.5A, Fast-Acting) Make sure circuit breaker is turned ON. Troubleshoot/repair source cause of overload; replace weak breaker; find/repair electrical short. Replace switch.
Poor adhesion.	<ol style="list-style-type: none"> Workpiece not properly cleaned/pre-treated prior to spraying. Coating under/over-cured. Powder coat too thick. 	<ol style="list-style-type: none"> Thoroughly clean workpiece; research/perform pretreatment recommendations for workpiece material and powder. Follow powder manufacturer's curing instructions. Reduce powder coat thickness when spraying.
Uneven spray pattern, intermittent powder flow.	<ol style="list-style-type: none"> Blockage in spray gun body/powder cup. Damp powder. Air pressure low. Powder flow regulating screw too tight. 	<ol style="list-style-type: none"> Disconnect tool from power, ground conducting pole, put on protective gear, and use air pressure to thoroughly clean spray gun and powder cup. Check powder source; replace powder if contaminated; replace in-line moisture filter(s). Increase air pressure up to 30 PSI. Loosen screw to increase powder flow.
Chipping after curing.	<ol style="list-style-type: none"> Workpiece not properly cleaned/pre-treated. Powder coat too thick. 	<ol style="list-style-type: none"> Thoroughly clean workpiece; research/perform pretreatment recommendations for workpiece material and powder. Reduce powder coat thickness when spraying.
Cratering after curing.	<ol style="list-style-type: none"> Powder is contaminated. Workpiece not properly cleaned/pre-treated prior to spraying. Damp powder. 	<ol style="list-style-type: none"> Thoroughly clean spray gun/powder cup; replace power with new. Thoroughly clean workpiece; research/perform pretreatment recommendations for workpiece material and powder. Check powder source; replace powder if contaminated; replace in-line moisture filter(s).
Off color after curing.	<ol style="list-style-type: none"> Oven not properly ventilated. Incorrect curing time/temperature. 	<ol style="list-style-type: none"> Make sure oven is well ventilated during curing. Follow powder manufacturer's curing instructions.
Orange peel.	<ol style="list-style-type: none"> Warming up of powder coat is too slow or too fast. Powder heat-damaged prior to spraying. Coating too thin. 	<ol style="list-style-type: none"> Check curing oven for proper operation; follow powder manufacturer's curing instructions. Thoroughly clean spray gun/powder cup; replace powder with new. Increase coating thickness when spraying.



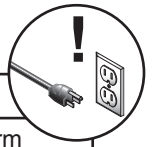

Symptom	Possible Cause	Possible Solution
Poor corrosion resistance.	<ol style="list-style-type: none">1. Workpiece not properly cleaned/pre-treated prior to spraying.2. Powder under-cured.	<ol style="list-style-type: none">1. Thoroughly clean workpiece; research/perform pretreatment recommendations for workpiece material and powder.2. Follow powder manufacturer's curing instructions.
Poor impact resistance or poor flexibility.	<ol style="list-style-type: none">1. Powder under-cured.2. Workpiece not properly cleaned/pre-treated prior to spraying.3. Coating too thick.	<ol style="list-style-type: none">1. Follow powder manufacturer's curing instructions.2. Thoroughly clean workpiece; research/perform pretreatment recommendations for workpiece material and powder.3. Decrease powder coat thickness when spraying.
Poor powder penetration into recessed areas.	<ol style="list-style-type: none">1. Poor workpiece ground.2. Improper spray pattern.	<ol style="list-style-type: none">1. Ensure system grounding clip is making good metal-to-metal contact with workpiece.2. Use a scatter tip that will help direct powder into recessed areas. Position spray gun so powder has a direct path to recessed areas.



SECTION 8: PARTS

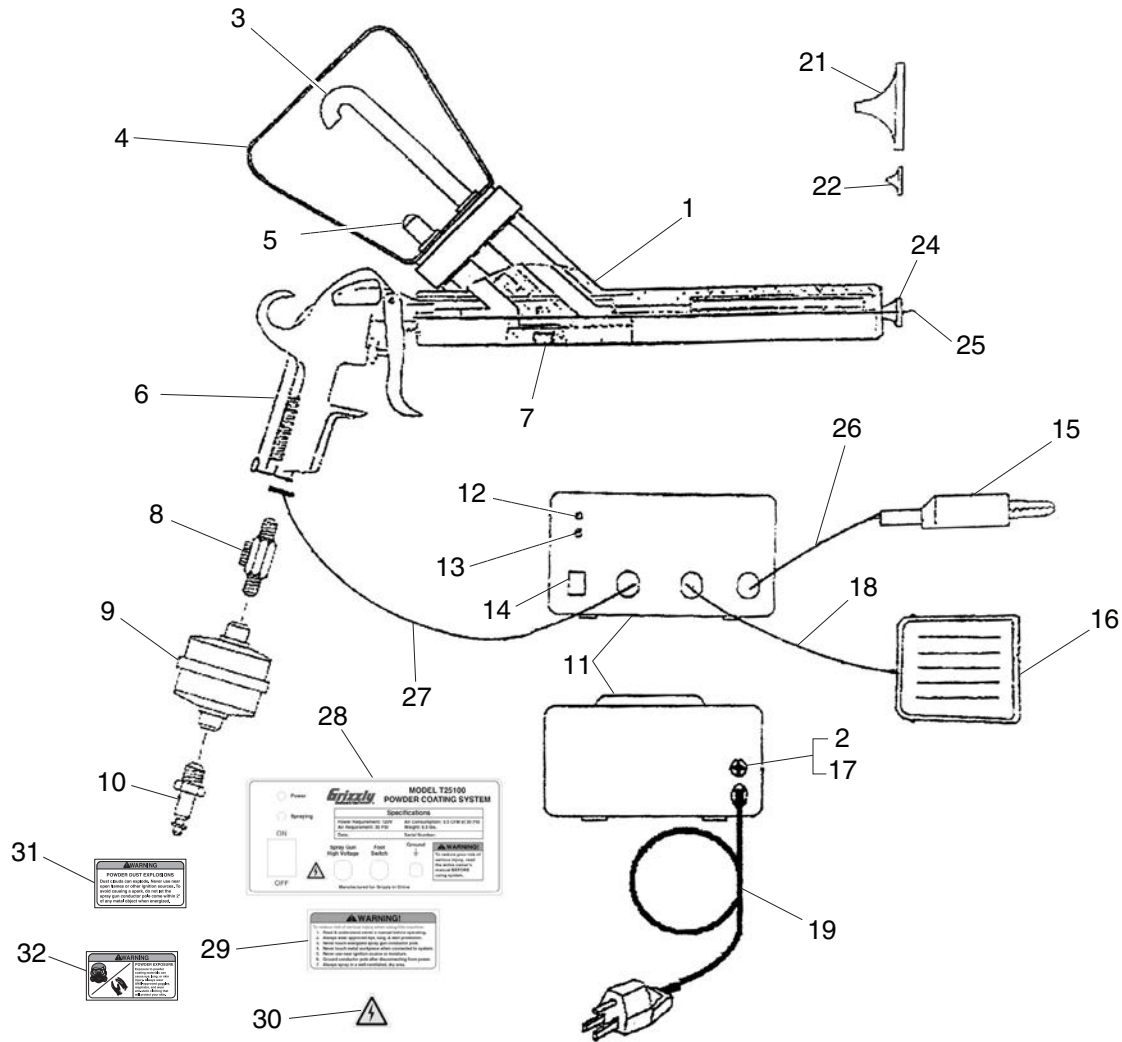

REF	PART #	DESCRIPTION
1	PT25100001	SPRAY GUN BODY
2	PT25100002	FUSE HOLDER
3	PT25100003	CUP AIR TUBE
4	PT25100004	POWDER CUP
5	PT25100005	CUP POWDER TUBE
6	PT25100006	SPRAY GUN HANDLE/TRIGGER ASSY
7	PT25100007	POWDER FLOW REGULATING SCREW
8	PT25100008	AIR PRESSURE REGULATING VALVE
9	PT25100009	MOISTURE FILTER
10	PT25100010	QUICK-CONNECT AIR ADAPTER 1/4 NPT
11	PT25100011	CONTROL BOX
12	PT25100012	POWER LIGHT
13	PT25100013	SPRAYING LIGHT
14	PT25100014	ON/OFF SWITCH
15	PT25100015	GROUNDING CLIP

REF	PART #	DESCRIPTION
16	PT25100016	FOOT SWITCH
17	PT25100017	FUSE 0.5A FAST-ACTING
18	PT25100018	FOOT SWITCH CABLE
19	PT25100019	POWER CORD 16G 3W 72" 5-15P
21	PT25100021	SCATTER TIP 1"
22	PT25100022	SCATTER TIP 3/4"
24	PT25100024	SCATTER TIP 1/2"
25	PT25100025	CONDUCTOR POLE
26	PT25100026	GROUNDING CABLE
27	PT25100027	SPRAY GUN CABLE
28	PT25100028	EQUIPMENT ID LABEL
29	PT25100029	WARNING LABEL
30	PLABEL-14A	ELECTRICITY LABEL
31	PT25100031	DUST EXPLOSION LABEL
32	PT25100032	POWDER EXPOSURE LABEL

Please Note: We do our best to stock replacement parts whenever possible, but we cannot guarantee that all parts shown here are available for purchase. Call (800) 523-4777 or visit our online parts store at www.grizzly.com to check for availability.



WARRANTY & RETURNS

Grizzly Industrial, Inc. warrants every product it sells for a period of **1 year** to the original purchaser from the date of purchase. This warranty does not apply to defects due directly or indirectly to misuse, abuse, negligence, accidents, repairs or alterations or lack of maintenance. This is Grizzly's sole written warranty and any and all warranties that may be implied by law, including any merchantability or fitness, for any particular purpose, are hereby limited to the duration of this written warranty. We do not warrant or represent that the merchandise complies with the provisions of any law or acts unless the manufacturer so warrants. In no event shall Grizzly's liability under this warranty exceed the purchase price paid for the product and any legal actions brought against Grizzly shall be tried in the State of Washington, County of Whatcom.

We shall in no event be liable for death, injuries to persons or property or for incidental, contingent, special, or consequential damages arising from the use of our products.

To take advantage of this warranty, contact us by mail or phone and give us all the details. We will then issue you a "Return Number," which must be clearly posted on the outside as well as the inside of the carton. We will not accept any item back without this number. Proof of purchase must accompany the merchandise.

The manufacturers reserve the right to change specifications at any time because they constantly strive to achieve better quality equipment. We make every effort to ensure that our products meet high quality and durability standards and we hope you never need to use this warranty.

Please feel free to write or call us if you have any questions about the machine or the manual.

Thank you again for your business and continued support. We hope to serve you again soon.

grizzly.com[®]
TOOL WEBSITE

Buy Direct and Save with Grizzly[®] – Trusted, Proven and a Great Value!
~Since 1983~

*Visit Our Website Today For
Current Specials!*

**ORDER
24 HOURS A DAY!
1-800-523-4777**

