

# *Grizzly* *Industrial, Inc.*®

## MODEL T21347 18 GAUGE 2" NAILER KIT OWNER'S MANUAL



COPYRIGHT © MARCH, 2009 BY GRIZZLY INDUSTRIAL, INC.  
WARNING: NO PORTION OF THIS MANUAL MAY BE REPRODUCED IN ANY SHAPE  
OR FORM WITHOUT THE WRITTEN APPROVAL OF GRIZZLY INDUSTRIAL, INC.

#TS11625 PRINTED IN CHINA

# SAFETY

## **WARNING**

### **For Your Own Safety Read Instruction Manual Before Operating This Equipment**

The purpose of safety symbols is to attract your attention to possible hazardous conditions. This manual uses a series of symbols and signal words which are intended to convey the level of importance of the safety messages. The progression of symbols is described below. Remember that safety messages by themselves do not eliminate danger and are not a substitute for proper accident prevention measures.



Indicates an imminently hazardous situation which, if not avoided, WILL result in death or serious injury.



Indicates a potentially hazardous situation which, if not avoided, COULD result in death or serious injury.



Indicates a potentially hazardous situation which, if not avoided, MAY result in minor or moderate injury. It may also be used to alert against unsafe practices.

**NOTICE**

This symbol is used to alert the user to useful information about proper operation of the equipment.

## **WARNING**

### **Safety Instructions For Pneumatic Tools**

- 1. KEEP ALL SAFETY DEVICES IN PLACE** and in working order.
- 2. REMOVE ADJUSTING KEYS AND WRENCHES.** Form habit of checking to see that keys and adjusting wrenches are removed from tool before operation.
- 3. KEEP WORK AREA CLEAN.** Cluttered areas and benches invite accidents.
- 4. DO NOT USE IN DANGEROUS ENVIRONMENT.** Do not use pneumatic tools in damp or wet locations, or where any flammable or noxious fumes may exist. Keep work area well lighted.
- 5. KEEP CHILDREN AND VISITORS AWAY.** All children and visitors should be kept at a safe distance from work area.
- 6. MAKE WORKSHOP CHILD PROOF** by locking your shop and shutting off air valves.
- 7. DO NOT FORCE TOOL.** It will do the job better and safer at the rate for which it was designed.
- 8. USE THE RIGHT TOOL.** Do not force tool or attachment to do a job for which it was not designed.
- 9. DO NOT USE UNDER THE INFLUENCE OF DRUGS OR ALCOHOL.**

# **WARNING**

## **Safety Instructions For Pneumatic Tools**

10. **USE PROPER AIR HOSE** for the tool. Make sure your air hose is in good condition and is long enough to reach your work without stretching.
11. **WEAR PROPER APPAREL.** Do not wear loose clothing, gloves, neckties, rings, bracelets, or other jewelry which may get caught in moving parts. Non-slip footwear is recommended. Wear a protective hair covering to contain long hair.
12. **ALWAYS USE ANSI APPROVED SAFETY GLASSES.** Also use a face or dust mask if cutting operation is dusty. Everyday eyeglasses only have impact resistant lenses, they are NOT safety glasses.
13. **WEAR APPROVED HEARING PROTECTION.**
14. **SECURE WORK.** Use clamps or a vise to hold work when practical. It is safer than using your hand and frees both hands to operate tool.
15. **MAINTAIN TOOLS WITH CARE.** Keep tools lubricated and clean for best and safest performance. Follow instructions for lubricating and changing accessories.
16. **REDUCE THE RISK OF UNINTENTIONAL STARTING.** Do not carry tool with hand on trigger and always disconnect from air when not in use.
17. **DISCONNECT TOOLS** before servicing, changing accessories, or moving to another location.
18. **DO NOT OVERREACH.** Keep proper footing and balance at all times.
19. **USE THE RECOMMENDED ACCESSORIES.** Consult owner's manual for recommended accessories. The use of improper accessories may cause risk of injury.
20. **CHECK FOR DAMAGED PARTS BEFORE USING.** Check for binding and alignment of parts, broken parts, part mounting, loose bolts, and any other conditions that may affect machine operation. Repair or replace damaged parts.
21. **NEVER LEAVE UNATTENDED TOOL CONNECTED TO AIR.** Disconnect the air hose and do not leave tool until it is relieved of any built up pressure.
22. **NEVER ALLOW UNTRAINED USERS TO USE THIS TOOL WHILE UNSUPERVISED.**
23. **IF YOU ARE UNSURE OF THE INTENDED OPERATION, STOP USING THE TOOL.** Seek formal training or research books or magazines that specialize in pneumatic tools.

# WARNING

## Additional Safety Instructions for Nailers/ Staplers

- 1. HAND INJURIES:** Do not place your hands near the nail/staple point of entry. A nail/staple can deflect and tear through the surface of the workpiece, puncturing your hand or fingers.
- 2. COMBUSTIBLE GASES:** Never connect the nailer/stapler to pressurized oxygen or other combustible gases as an air source. Only use filtered, lubricated, and regulated compressed air.
- 3. SAFE HANDLING:** Never point the nailer/stapler at others! Do not keep the trigger pulled when loading fasteners, carrying, or holding tool. Carry the tool only by the handle, never by any other part. Do not carry the tool by the air hose. Disconnect the nailer/stapler from the air hose when going up and down ladders.
- 4. MODIFICATIONS:** DO NOT modify this tool or bypass the safety nose mechanism.
- 5. COMPRESSED AIR RATING:** Do not connect the nailer/stapler to compressed air that exceeds 120 PSI.
- 6. HOSE USAGE:** Make sure your air hose is designed for the tool in use, is in good condition, and is long enough to reach your work without stretching. However, an overly long air hose in the work area may be a tripping hazard.
- 7. OPERATING QUESTIONS:** If you are not sure about the intended operation, stop using the nailer/stapler. Seek formal training.
- 8. CLEANING:** Never use gasoline or other flammable liquids to clean the nailer; vapors in the nailer/stapler will ignite by a spark and cause it to explode.
- 9. MAINTENANCE:** Always disconnect air from the nailer/stapler when servicing or installing nails. During maintenance, a nailer/stapler connected to air may fire accidentally, causing serious personal injury.
- 4. CHECK VALVE:** Do not use a check valve or any other fitting that allows air to remain in the tool after it is disconnected from the air source.

# ⚠️ WARNING

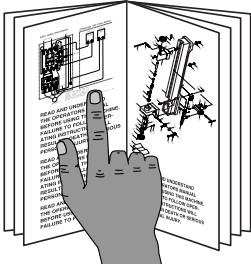

Read the manual before operation. Become familiar with this nailer, its safety instructions, and its operation before beginning any work. Serious personal injury may result if safety or operational information is not understood or followed.

# ⚠️ WARNING

Never point this nailer at yourself or another person! Always pay attention to the direction this nailer is pointed. Use this tool with respect and caution to lessen the possibility of operator or bystander injury. Ignoring this warning may result in serious personal injury.

# ⚠️ CAUTION

Nailer/stapler accidents routinely happen while moving the gun to another location, such as up ladders, to another room, or even another job site. Always disconnect the gun immediately after use and never transport the gun while connected to the air—even if the air compressor is disconnected from its power source!

# ⚠️ WARNING

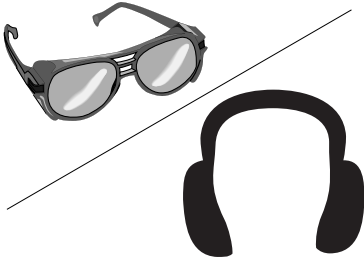

Operating this nailer can propel objects into the air, causing immediate eye damage. To protect yourself, always wear American National Standards Institute (ANSI) approved safety glasses or goggles when operating this equipment. In addition, this nailer discharges at up to 85-90 decibels. To protect your hearing, always wear ANSI approved ear protection when operating this nailer.

# ⚠️ CAUTION

No list of safety guidelines can be complete. Every shop environment is different. Always consider safety first, as it applies to your individual working conditions. Use this and other tools with caution and respect. Failure to do so could result in serious personal injury, damage to equipment or poor work results.

# INTRODUCTION

---

---

## Foreword

---

---

We are proud to offer the Grizzly Model T21347 2" Nailer Kit. This model is part of a growing Grizzly family of fine pneumatic tools. When used according to the guidelines set forth in this manual, you can expect years of trouble-free, enjoyable operation and proof of Grizzly's commitment to customer satisfaction.

The Model T21347 features a 360° exhaust port, comfort grip rubber handle, and economical air consumption with low noise.

The specifications, details, and photographs in this manual represent the Model T21347 as supplied when the manual was prepared. However, owing to Grizzly's policy of continuous improvement, changes may be made at any time with no obligation on the part of Grizzly.

## Specifications

---

---

Nail Size .....18 Gauge  
Nail Length ..... $\frac{5}{8}$ "-2"  
Magazine Capacity ..... 100 Nails  
Air Inlet .....  $\frac{1}{4}$ " NPT  
Weight .....3.8 lbs.  
Operating Pressure .....60-100 PSI

## Contact Info

---

---

If you have any comments regarding this manual, please write to us at the following address:

Grizzly Industrial, Inc.  
C/O Technical Documentation Manager  
P.O. Box 2069  
Bellingham, WA 98227-2069

Most importantly, we stand behind our tools. If you have any service questions or parts requests, please call or write us at the location listed below.

Grizzly Industrial, Inc.  
1203 Lycoming Mall Circle  
Muncy, PA 17756  
Phone: (570) 546-9663  
Fax: (800) 438-5901  
E-Mail: [techsupport@grizzly.com](mailto:techsupport@grizzly.com)  
Web Site: <http://www.grizzly.com>

# SET UP

## Unpacking

Your Model T21347 left our warehouse in a carefully packed box. If you discover the nailer is damaged after you have signed for delivery, *please immediately call Customer Service at (570) 546-9663 for advice.*

Save the containers and all packing materials for possible inspection by the carrier or its agent. *Otherwise, filing a freight claim can be difficult.*

When you are completely satisfied with the condition of the shipment, you should inventory the equipment.

## Inventory

After you open the nailer box, you should find the following.

### Model T21347 Inventory (Figure 1)

A. Nailer.....	1
B. Safety Goggles .....	1
C. Pneumatic Tool Oil .....	1
D. Hex Wrench 3MM .....	1
E. Hex Wrench 4MM .....	1
F. Carrying Case.....	1

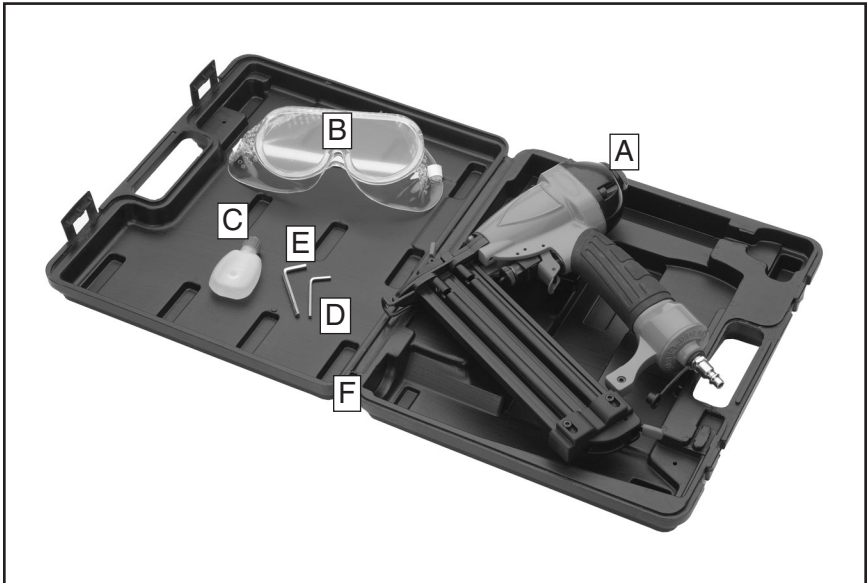

Figure 1. Model T21347 inventory.

# Compressed Air System

The Model T21347 is designed to be operated at 60–100 PSI using clean, dry, regulated, compressed air. **DO NOT exceed the maximum operating pressure for your model.**

Before using your new nailer, regulate the air pressure on your air compressor to the minimum PSI for your model.

An in-line filter/lubricator/regulator unit, depicted in **Figure 2**, can be installed and should be located as close to the nailer as possible.

This filter/lubricator/regulator unit will protect your tool from damaging water build-up, allow you to adjust and maintain constant air pressure to your tool, and save you the inconvenience of having to manually lubricate your tool every time you use it.

## ⚠ WARNING

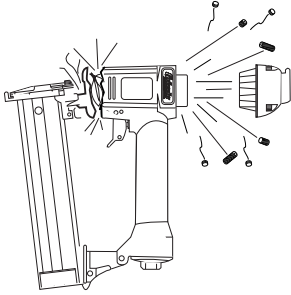

**Exceeding the maximum permissible operating pressure may cause the nailer to explode, blowing metal fragments in all directions. To protect yourself from serious personal injury, DO NOT allow your air compressor to exceed the recommended pressure when connected to this nailer!**

Check the current Grizzly catalog for availability of this unit. If you plan on installing a filter/lubricator/regulator unit in your compressed air system, always follow the connection instructions that come with the unit.

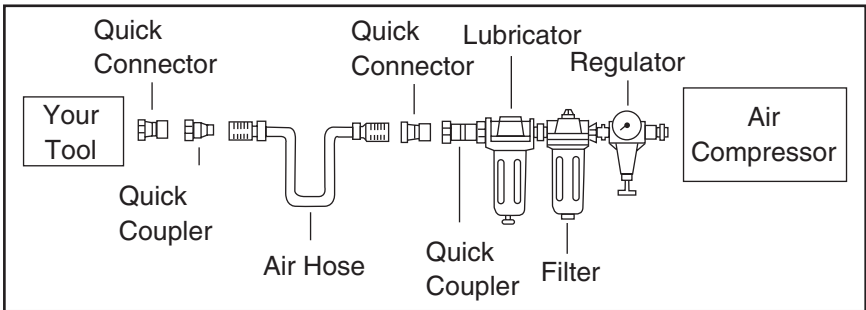

**Figure 2.** Typical filter/lubricator/regulator installation order.



# Safety Nose Mechanism

---

---

A safety mechanism on the nose of the nailer protects against accidental firing. When the trigger is pressed, the nailer will not fire until the safety nose mechanism is depressed.

Before you use your nailer for the first time, check the safety nose mechanism to ensure proper function. To do this:

1. DISCONNECT NAILER FROM THE AIR SUPPLY!
2. Make sure the magazine is empty and contains no nails.
3. Make sure the trigger and the safety nose mechanism move up and down without sticking.
4. Connect the nailer to the air supply.

## **WARNING**

**The safety mechanism is a mechanical device that can fail. Never rely on this mechanism as an excuse to point the nailer at yourself or any bystanders. Serious injury may occur.**

5. **Without pressing the trigger**, depress the safety nose mechanism against a scrap piece of wood that is clean and free of any knots, nails, or other foreign objects.

— If the nailer does not fire, then the safety nose mechanism is working correctly.

— If the nailer **does fire** when you do this, immediately disconnect the nailer from the air supply and call Grizzly Technical Support at (570) 546-9663 for help.

— If the nailer fires when the trigger is pulled, without the safety nose mechanism being depressed, then immediately disconnect the nailer from the air supply and call Grizzly Technical Support at (570) 546-9663 for help.

— If you find that the safety nose mechanism is not working properly, check the lubrication of its sliding components.

# OPERATIONS

---

---

## Loading

---

---

When replacing nails in your Model T21347, follow these guidelines:

Gauge: 18  
Length:  $\frac{5}{8}$ "-2"  
Capacity: 100

### To load your nailer:

1. DISCONNECT NAILER FROM THE AIR SUPPLY!
2. Sliding magazine pusher back, as shown in **Figure 3**, to lock the catch lever in place.

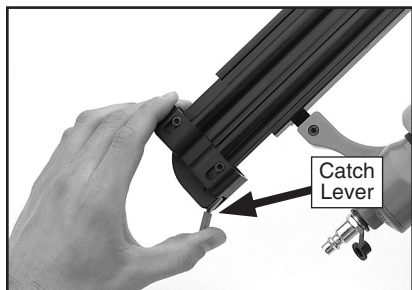

**Figure 3.** Sliding magazine pusher back and locking catch lever in place.

3. Insert a strip of nails, pointed-end down, into the magazine as shown in **Figure 4**.

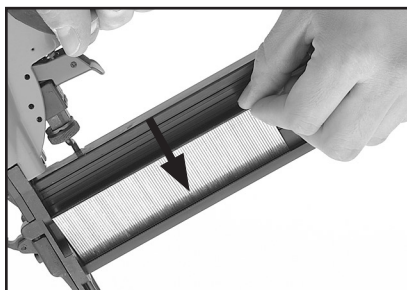

**Figure 4.** Loading nails into magazine.

4. Slide the nails all the way down to the nose of the nailer.
5. Push the magazine pusher all the way in until the catch lever locks.

## Operating

---

---

**If you have not read the safety instructions in this manual, do not operate the nailer.**

Before you operate your nailer, place five to six drops of the included oil into the quick connect fitting where the nailer connects to the air supply.

### To operate your nailer:

1. Connect the air supply to the quick connect fitting.
2. To test for proper nail penetration, hold the nailer perpendicular to the surface of a piece of clean scrap wood that is thick enough for the length of nails you have loaded.

3. Depress the safety nose mechanism against your workpiece.
4. Before pulling the trigger, make sure your free hand and other body parts are positioned out of the way of a potential path of a nail in case of deflection.

Deflection is caused when grain irregularities, knots or foreign objects inside the wood cause the nail to change its path, resulting in the nail puncturing the surface of the workpiece, as shown in **Figure 5**.

Besides damaging your workpiece, deflection can cause injury if your free hand is securing the workpiece in the location that the nail deflects.

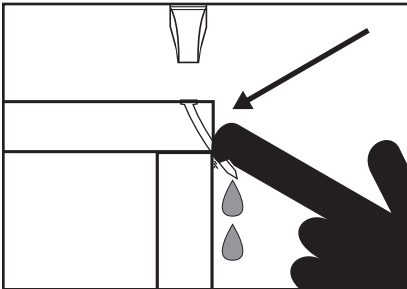

**Figure 5.** Example of nail deflection.

5. Pull the trigger.
  - If the nail drove into the wood far enough, continue with your intended operations.
  - If the nail either went too far or not far enough, then go to the **Adjusting Depth** subsection on this page.

## Adjusting Depth

A depth adjustment knob is attached to the nose for setting the nail depth.

### To adjust the depth:

1. DISCONNECT NAILER FROM THE AIR SUPPLY!
2. Rotate the adjustment knob (**Figure 6**) clockwise to drive the nails deeper or counterclockwise to drive the nails shallower.

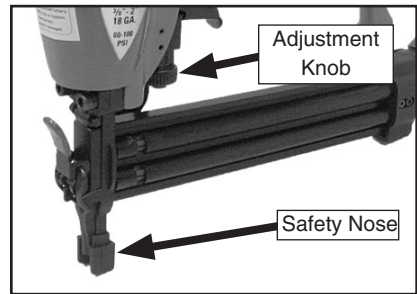

**Figure 6.** Depth adjustment controls.

3. Connect nailer to the air supply and test the nail depth, and repeat this entire procedure if necessary until the nail depth is satisfactory.

# Clearing Jammed Nails

---

---

A jammed nail must be cleared before using the nailer again.

**To clear a jammed nail from the discharge area:**

1. DISCONNECT NAILER FROM THE AIR SUPPLY!
2. Release the catch lever and slide the magazine pusher back.
3. Remove the nail stick from the magazine.

4. Open the nailer nose by removing the rubber nose tip, depressing the nose release mechanism, and opening the nose cover as shown in **Figure 7**.

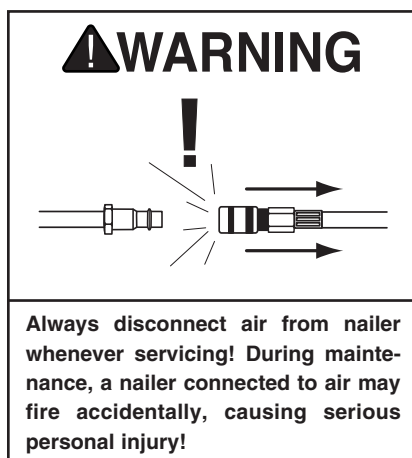

**Figure 7.** Nose opened to clear a jam.

5. Dislodge the jammed nail with a tool that will fit in the slot on the underside of the nose.
6. Throw the damaged nail away and insert a new nail stick that only contains clean, undamaged nails. **DO NOT** use dirty or damaged nails!
7. Slide the pusher back until it locks into position.

# Replacing Pistons & O-Rings

If you use your nailer day in and day out, repair pistons are cheap insurance against wasted down time and lost profits, in the event that a piston or piston shaft becomes worn out. The Piston & O-Ring Repair Kit, part PT21347087, may be purchased for the Model T21347 from Grizzly.



## To replace a piston:

1. DISCONNECT NAILER FROM THE AIR SUPPLY!
2. Remove all nails from the magazine cartridge.
3. Remove the four cap screws on the top of the nailer, near the exhaust port, and remove the cap. The top of the piston should now be visible inside the cylinder, which is housed in the head of the nailer.
4. Open the nose cover as if to clear a jammed nail.
5. Watch the discharge area and push the top of the piston with your finger. You will see the piston shaft slide down the discharge area.
6. With a long flathead screwdriver or similarly shaped tool, push the piston shaft back inside the nailer until you can grip the piston head and remove it from the cylinder. (Be careful not to scratch the discharge area when pushing the piston shaft with the screwdriver.)
7. Place a new O-ring on the new piston and apply a thin film of the nailer lubricating oil on the O-ring.
8. Insert the new piston in the cylinder. Make sure that the grooves on the piston shaft line up with those on the guide at the bottom of the cylinder. The new piston should easily slide into the cylinder. **DO NOT force the piston into the cylinder!** If the piston is not easily inserted, double-check the alignment of the piston shaft with the grooves on the guide.
9. After the piston is inserted correctly, close the magazine. Replace the top cap assembly and tighten the four cap screws.
10. For more assistance, or to install a complete O-ring set, refer to the breakdown diagram in the back of this manual for component locations.

# CLEANING & LUBRICATION

## Cleaning

Use a good solvent to clean the nose assembly of the nailer. Always be sure that the nailer is dry before using it again.

Do not allow dust, chips, sand, etc. into the air connectors or into the body of the nailer; this may result in leaks and damage to the nailer and the air couplings.

**WARNING**



**Never use gasoline or other flammable liquids to clean this tool. Vapors in the tool may ignite, causing the tool to explode. Ignoring this warning may lead to serious personal injury or even death!**

## Lubricating

Special oil has been included with your new Grizzly nailer to help maintain its useful life. Place two to six drops of oil in the nailer air inlet (as shown in **Figure 8**) every 2 hours of continuous use.

Wipe off any excess oil near the nailer exhaust to avoid dust build-up. When the oil that was included with the nailer has been completely used, replace with Grizzly Model G2820 Pneumatic Tool Oil.

Another option to manual oiling would be to simply install a lubricator in your air compressor line. If your air compressor line already has a lubricator, then regular lubrication of your nailer will not be necessary. Just make sure there is always oil in the lubricator.

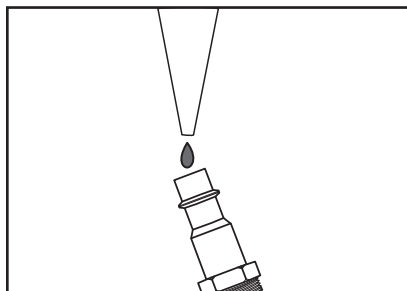
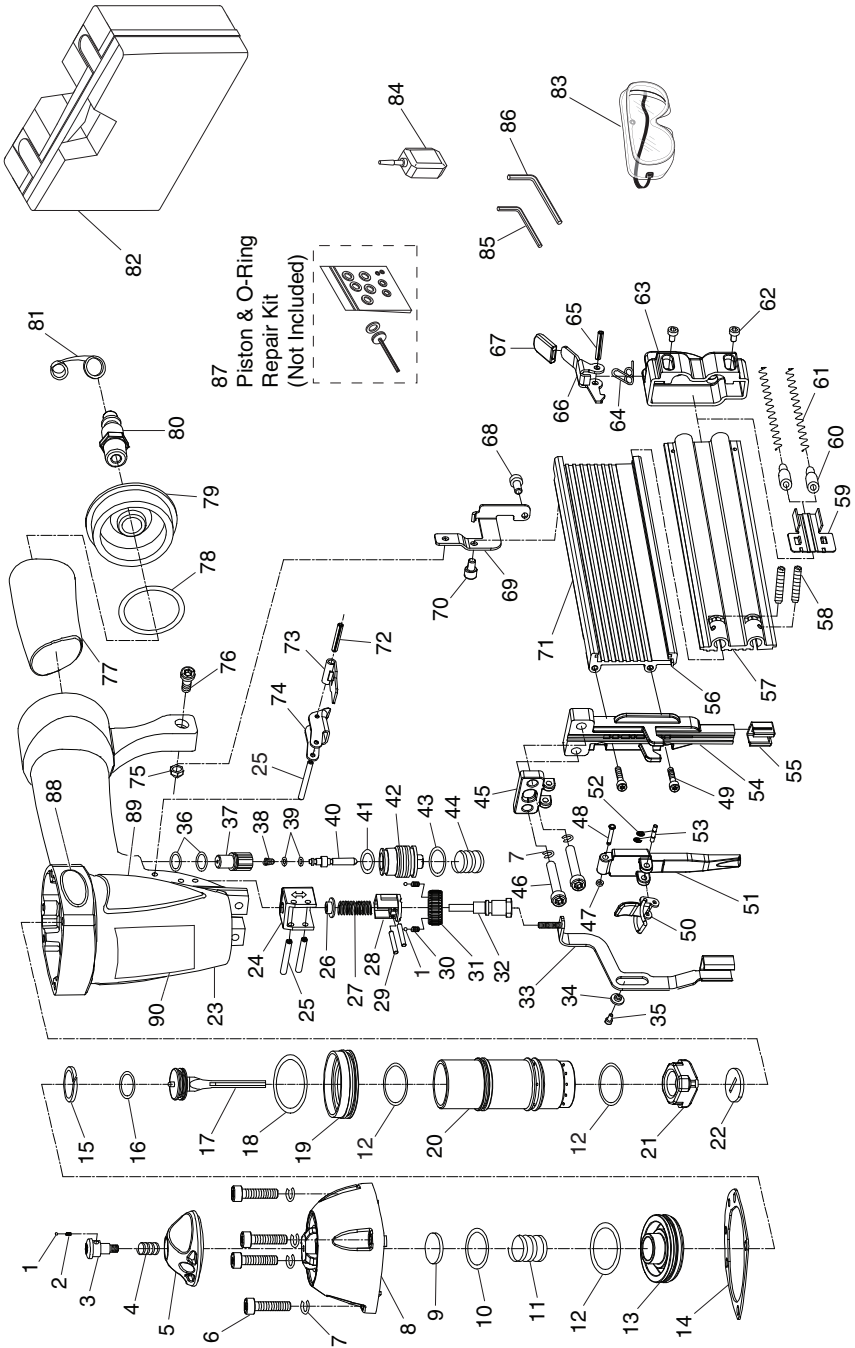

**Figure 8.** Lubricating nailer via air inlet.

# TROUBLESHOOTING

Symptom	Possible Cause	Solution
Air leaking at trigger valve area.	1. O-rings in trigger valve housing are damaged.	1. O-rings must be replaced & operation of safety nose must be checked.
Air leaking between housing and hose.	1. Loose screws in housing. 2. Damaged O-ring. 3. Loose air fitting.	1. Tighten screws. 2. Replace O-ring. 3. Tighten air fitting & use teflon tape.
Air leaking between housing and cap assembly.	1. Damaged seal.	1. Replace damaged seals.
Tool skips nails while discharging.	1. Incorrect air pressure. 2. Air leaks. 3. Dirt in nose. 4. Dirt or damage prevents nails from moving freely. 5. Worn piston O-ring or lack of lubrication. 6. Damaged trigger valve O-rings. 7. Worn bumper. 8. Cap seal leaking.	1. Use correct air pressure. 2. Tighten screws and fittings. 3. Clean nose. 4. Clean magazine and inspect/repair damage. 5. Replace O-ring and lubricate. 6. Replace trigger valve O-rings. 7. Replace bumper. 8. Replace cap seal.
Tool runs slowly or has a loss of power.	1. Nailer is not lubricated. 2. Broken spring in cap assembly. 3. Exhaust port in cap is blocked.	1. Lubricate nailer. 2. Replace spring. 3. Clean or replace damaged internal parts.
Fasteners frequently jam the nailer.	1. Nails are the wrong size. 2. Nails are bent or dirty. 3. Magazine or nose screws are loose. 4. Driver or driver guide are worn or damaged. 5. Nails are wrong angle.	1. Use correct nails. 2. Use undamaged, clean nails. 3. Tighten magazine. 4. Replace worn or damaged parts. 5. Use correct angle nails.
Nailer does not fire.	1. Nailer is not lubricated. 2. Nail is jammed in magazine or discharge area. 3. Piston shaft is damaged. 4. Air pressure too low.	1. Follow lubricating instructions. 2. Clear nailer magazine or discharge area. 3. Replace piston shaft. 4. Check/increase air pressure.
Air blows out of exhaust cap; nailer will not fire.	1. O-ring damaged or slipped out of groove on switch piston, inside the nailer.	1. Reinstall/replace suspect O-ring; turn down the air pressure to prevent it happening again.

# Main Breakdown





# Main Parts List

REF	PART #	DESCRIPTION
1	PT21347001	STEEL BALL 2.5MM
2	PT21347002	COMPRESSION SPRING
3	PT21347003	AIR DEFLECTOR BOLT
4	PT21347004	AIR DEFLECTOR SPRING
5	PT21347005	AIR DEFLECTOR
6	PSB15M	CAP SCREW M5-.8 X 20
7	PLW01M	LOCK WASHER 5MM
8	PT21347008	CYLINDER COVER
9	PT21347009	SEALING WASHER
10	PORP018	O-RING 17.8 X 2.4 P18
11	PT21347011	VALVE SPRING
12	PORS034	O-RING 33.5 X 2.0 S34
13	PT21347013	HEAD VALVE PISTON
14	PT21347014	GASKET
15	PT21347015	PISTON SEALING RING
16	PT21347016	O-RING 23 X 5.2
17	PT21347017	MAIN PISTON
18	POR0042	O-RING 41.6 X 3
19	PT21347019	COLLAR
20	PT21347020	CYLINDER
21	PT21347021	BUMPER
22	PT21347022	DRIVE GUIDE WASHER
23	PT21347023	NAILER BODY
24	PT21347024	GUIDE SEAT
25	PRP55M	ROLL PIN 3 X 27
26	PT21347026	ADJUSTMENT WASHER
27	PT21347027	COMPRESSION SPRING
28	PT21347028	ADJUSTMENT SEAT
29	PT21347029	PIN 1.5 X 8
30	PT21347030	POSITIONING SPRING
31	PT21347031	DEPTH ADJUSTMENT WHEEL
32	PT21347032	DRIVER STEM
33	PT21347033	SAFETY STEM
34	PT21347034	SPECIAL WASHER
35	PSB80M	CAP SCREW M3-.5 X 8
36	PORS008	O-RING 7.5 X 1.5 S8
37	PT21347037	VALVE CASE
38	PT21347038	COMPRESSION SPRING
39	PH6332035	O-RING 1.9 X 1.1
40	PT21347040	TRIGGER PIN
41	PORP012	O-RING 11.8 X 2.4 P12
42	PT21347042	TRIGGER SEAT
43	PORP012	O-RING 11.8 X 2.4 P12
44	PT21347044	COMPRESSION SPRING
45	PT21347045	FIXED PLATE

REF	PART #	DESCRIPTION
46	PSB38M	CAP SCREW M5-.8 X 25
47	PT21347047	SHAFT RETAINER
48	PT21347048	SHAFT
49	PSB16M	CAP SCREW M4-.7 X 16
50	PT21347050	LATCH
51	PT21347051	DRIVER PLATE
52	PEC16M	E-CLIP 2.5MM
53	PT21347053	SPECIAL PIN
54	PT21347054	NOSE
55	PT21347055	NOSE TIP
56	PT21347056	NAIL PLATE
57	PT21347057	SLIDING MAGAZINE
58	PS22M	SET SCREW M4-.7 X 12
59	PT21347059	PUSHER
60	PT21347060	PUSHER PIN
61	PT21347061	COMPRESSION SPRING
62	PSB17M	CAP SCREW M4-.7 X 10
63	PT21347063	MAGAZINE END BRACKET
64	PT21347064	LATCH SPRING
65	PRP42M	ROLL PIN 3 X 20
66	PT21347066	LOCK LATCH
67	PT21347067	LATCH END COVER
68	PSB18M	CAP SCREW M4-.7 X 8
69	PT21347069	BRACKET
70	PSB110M	CAP SCREW M4-.7 X 6
71	PT21347071	FIXED MAGAZINE
72	PRP64M	ROLL PIN 3 X 18
73	PT21347073	TRIGGER LOCK
74	PT21347074	TRIGGER
75	PLN01M	LOCK NUT M4-.7
76	PSB41M	CAP SCREW M4-.7 X 14
77	PT21347077	GRIP
78	PORP038	O-RING 37.7 X 3.5 P38
79	PT21347079	END CAP
80	PT21347080	AIR INLET VALVE
81	PT21347081	AIR INLET VALVE CAP
82	PT21347082	CARRYING CASE
83	PT21347083	SAFETY GOGGLES
84	PT21347084	OIL BOTTLE
85	PAW03M	HEX WRENCH 3MM
86	PAW04M	HEX WRENCH 4MM
87	PT21347087	PISTON & O-RING REPAIR KIT
88	PT21347088	GRIZZLY.COM LABEL
89	PT21347089	TOOL ID LABEL
90	PT21347090	WARNINGS LABEL

# WARRANTY AND RETURNS

---

Grizzly Industrial, Inc. warrants every product it sells for a period of **1 year** to the original purchaser from the date of purchase. This warranty does not apply to defects due directly or indirectly to misuse, abuse, negligence, accidents, repairs or alterations or lack of maintenance. This is Grizzly's sole written warranty and any and all warranties that may be implied by law, including any merchantability or fitness, for any particular purpose, are hereby limited to the duration of this written warranty. We do not warrant or represent that the merchandise complies with the provisions of any law or acts unless the manufacturer so warrants. In no event shall Grizzly's liability under this warranty exceed the purchase price paid for the product and any legal actions brought against Grizzly shall be tried in the State of Washington, County of Whatcom.

We shall in no event be liable for death, injuries to persons or property or for incidental, contingent, special, or consequential damages arising from the use of our products.

To take advantage of this warranty, contact us by mail or phone and give us all the details. We will then issue you a "Return Authorization Number," which must be clearly posted on the outside as well as the inside of the carton. We will not accept any item back without this number. Proof of purchase must accompany the merchandise.

The manufacturers reserve the right to change specifications at any time because they constantly strive to achieve better quality equipment. We make every effort to ensure that our products meet high quality and durability standards and we hope you never need to use this warranty.

Please feel free to write or call us if you have any questions about the machine or the manual.

**Grizzly Industrial, Inc.**  
**1203 Lycoming Mall Circle**  
**Muncy, PA 17756**  
**Phone: (570) 546-9663**  
**Fax: (800) 438-5901**

**E-Mail:**  
**techsupport@grizzly.com**

**Web Site: <http://www.grizzly.com>**

Thank you again for your business and continued support. We hope to serve you again soon!



# WARRANTY CARD

Name \_\_\_\_\_

Street \_\_\_\_\_

City \_\_\_\_\_ State \_\_\_\_\_ Zip \_\_\_\_\_

Phone # \_\_\_\_\_ Email \_\_\_\_\_ Invoice # \_\_\_\_\_

Model # \_\_\_\_\_ Order # \_\_\_\_\_ Serial # \_\_\_\_\_

*The following information is given on a voluntary basis. It will be used for marketing purposes to help us develop better products and services. **All information is strictly confidential.***

1. How did you learn about us?

Advertisement     Friend     Catalog  
 Card Deck     Website    Other: \_\_\_\_\_

2. Which of the following magazines do you subscribe to?

Cabinet Maker     Popular Mechanics     Today's Homeowner  
 Family Handyman     Popular Science     Wood  
 Hand Loader     Popular Woodworking     Wooden Boat  
 Handy     Practical Homeowner     Woodshop News  
 Home Shop Machinist     Precision Shooter     Woodsmith  
 Journal of Light Cont.     Projects in Metal     Woodwork  
 Live Steam     RC Modeler     Woodworker West  
 Model Airplane News     Rifle     Woodworker's Journal  
 Modeltec     Shop Notes     Other:  
 Old House Journal     Shotgun News

3. What is your annual household income?

\$20,000-\$29,000     \$30,000-\$39,000     \$40,000-\$49,000  
 \$50,000-\$59,000     \$60,000-\$69,000     \$70,000+

4. What is your age group?

20-29     30-39     40-49  
 50-59     60-69     70+

5. How long have you been a woodworker/metalworker?

0-2 Years     2-8 Years     8-20 Years     20+ Years

6. How many of your machines or tools are Grizzly?

0-2     3-5     6-9     10+

7. Do you think your machine represents a good value?  Yes     No

8. Would you recommend Grizzly Industrial to a friend?  Yes     No

9. Would you allow us to use your name as a reference for our customers in your area?

Note: *We never use names more than 3 times.*     Yes     No

10. Comments: \_\_\_\_\_

\_\_\_\_\_

\_\_\_\_\_

\_\_\_\_\_

Send a Grizzly Catalog to a friend:

Name _____
Street _____
City _____ State _____ Zip _____

FOLD ALONG DOTTED LINE

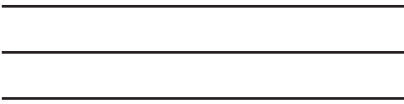

Place  
Stamp  
Here



GRIZZLY INDUSTRIAL, INC.  
P.O. BOX 2069  
BELLINGHAM, WA 98227-2069



TAPE ALONG EDGES--PLEASE DO NOT STAPLE