

Grizzly *Industrial, Inc.*®

MODEL T20644

34° ANGLE FINISH NAILER

INSTRUCTION MANUAL



COPYRIGHT © MARCH, 2008 BY GRIZZLY INDUSTRIAL, INC.,
**WARNING: NO PORTION OF THIS MANUAL MAY BE REPRODUCED IN ANY SHAPE
OR FORM WITHOUT THE WRITTEN APPROVAL OF GRIZZLY INDUSTRIAL, INC.**

#TR10583 PRINTED IN CHINA

WARNING!

This manual provides critical safety instructions on the proper setup, operation, maintenance and service of this machine/equipment.

Failure to read, understand and follow the instructions given in this manual may result in serious personal injury, including amputation, electrocution or death.

The owner of this machine/equipment is solely responsible for its safe use. This responsibility includes but is not limited to proper installation in a safe environment, personnel training and usage authorization, proper inspection and maintenance, manual availability and comprehension, application of safety devices, blade/cutter integrity, and the usage of personal protective equipment.

The manufacturer will not be held liable for injury or property damage from negligence, improper training, machine modifications or misuse.

WARNING!

Some dust created by power sanding, sawing, grinding, drilling, and other construction activities contains chemicals known to the State of California to cause cancer, birth defects or other reproductive harm. Some examples of these chemicals are:

- Lead from lead-based paints.
- Crystalline silica from bricks, cement and other masonry products.
- Arsenic and chromium from chemically-treated lumber.

Your risk from these exposures varies, depending on how often you do this type of work. To reduce your exposure to these chemicals: Work in a well ventilated area, and work with approved safety equipment, such as those dust masks that are specially designed to filter out microscopic particles.

SAFETY

WARNING

For Your Own Safety Read Instruction Manual Before Operating This Equipment

The purpose of safety symbols is to attract your attention to possible hazardous conditions. This manual uses a series of symbols and signal words which are intended to convey the level of importance of the safety messages. The progression of symbols is described below. Remember that safety messages by themselves do not eliminate danger and are not a substitute for proper accident prevention measures.



Indicates an imminently hazardous situation which, if not avoided, **WILL** result in death or serious injury.



Indicates a potentially hazardous situation which, if not avoided, **COULD** result in death or serious injury.



Indicates a potentially hazardous situation which, if not avoided, **MAY** result in minor or moderate injury. It may also be used to alert against unsafe practices.

NOTICE

This symbol is used to alert the user to useful information about proper operation of the equipment.

WARNING

Safety Instructions For Pneumatic Tools

- KEEP ALL SAFETY DEVICES IN PLACE** and in working order.
- REMOVE ADJUSTING KEYS AND WRENCHES.** Form habit of checking to see that keys and adjusting wrenches are removed from tool before operation.
- KEEP WORK AREA CLEAN.** Cluttered areas and benches invite accidents.
- DO NOT USE IN DANGEROUS ENVIRONMENT.** Do not use pneumatic tools in damp or wet locations, or where any flammable or noxious fumes may exist. Keep work area well lighted.
- KEEP CHILDREN AND VISITORS AWAY.** All children and visitors should be kept at a safe distance from work area.
- MAKE WORKSHOP CHILD PROOF** by locking your shop and shutting off air valves.
- DO NOT FORCE TOOL.** It will do the job better and safer at the rate for which it was designed.
- USE THE RIGHT TOOL.** Do not force tool or attachment to do a job for which it was not designed.
- DO NOT USE UNDER THE INFLUENCE OF DRUGS OR ALCOHOL.**

WARNING

Safety Instructions For Pneumatic Tools

10. **USE PROPER AIR HOSE** for the tool. Make sure your air hose is in good condition and is long enough to reach your work without stretching.
11. **WEAR PROPER APPAREL.** Do not wear loose clothing, gloves, neckties, rings, bracelets, or other jewelry which may get caught in moving parts. Non-slip footwear is recommended. Wear a protective hair covering to contain long hair.
12. **ALWAYS USE SAFETY GLASSES.** Also use a face or dust mask if cutting operation is dusty. Everyday eyeglasses only have impact resistant lenses, they are NOT safety glasses.
13. **WEAR APPROVED HEARING PROTECTION.** Air escaping from pneumatic tools can exceed safe exposure limits and may cause hearing damage with prolonged exposure.
14. **SECURE WORK.** Use clamps or a vise to hold work when practical. It is safer than using your hand and frees both hands to operate tool.
15. **MAINTAIN TOOLS WITH CARE.** Keep tools lubricated and clean for best and safest performance. Follow instructions for lubricating and changing accessories.
16. **REDUCE THE RISK OF UNINTENTIONAL FIRING.** Do not carry tool with hand on trigger and always disconnect from air when not in use.
17. **DISCONNECT TOOLS** before servicing, changing accessories, or moving to another location.
18. **DO NOT OVERREACH.** Keep proper footing/balance at all times.
19. **USE THE RECOMMENDED ACCESSORIES.** Consult owner's manual for recommended accessories. The use of improper accessories may cause risk of injury.
20. **CHECK FOR DAMAGED PARTS BEFORE USING.** Check for binding and alignment of parts, broken parts, part mounting, loose bolts, and any other conditions that may affect machine operation. Repair or replace damaged parts.
21. **NEVER LEAVE UNATTENDED TOOL CONNECTED TO AIR.** Disconnect the air hose and do not leave tool until it is relieved of any built up pressure.
22. **NEVER ALLOW UNTRAINED USERS TO USE THIS TOOL WHILE UNSUPERVISED.**
23. **IF YOU ARE UNSURE OF THE INTENDED OPERATION, STOP USING TOOL.** Seek formal training or research books or magazines that specialize in pneumatic tools.
24. **BE AWARE OF HOSE LOCATION WHEN USING PNEUMATIC TOOLS.** Hoses can easily become a tripping hazard when laid across the floor or spread out in a disorganized fashion.

WARNING

Additional Safety Instructions for Nailers

1. **HAND INJURIES:** Do not place your hands near the nail point of entry. A nail can deflect and tear through the surface of the workpiece, puncturing your hand or fingers.
2. **COMBUSTIBLE GASES:** Never connect the nailer to pressurized oxygen or other combustible gases as a power source. Only use filtered, lubricated, and regulated compressed air.
3. **SAFE HANDLING:** Never point the nailer at others! Do not keep the trigger pulled when loading fasteners, carrying, or holding tool. Carry the nailer only by the handle, never by any other part. Do not carry the nailer by the air hose. Disconnect the nailer from the air hose when going up and down ladders.
4. **MODIFICATIONS:** DO NOT modify this tool or bypass the safety nose mechanism.
5. **CHECK VALVE:** Do not use a check valve or any other fitting that allows air to remain in the tool.
6. **HOSE USAGE:** Make sure your air hose is designed for the tool in use, is in good condition, and is long enough to reach your work without stretching. However, an overly long air hose in the work area may be a tripping hazard if not kept out of the way.
7. **OPERATING QUESTIONS:** If you are not sure about the intended operation, stop using the nailer. Seek formal training.
8. **CLEANING:** Never use gasoline or other flammable liquids to clean the nailer; vapors in the nailer will ignite by a spark and cause it to explode.
9. **MAINTENANCE:** Always disconnect air from the nailer when servicing or installing nails. During maintenance, a nailer connected to air may fire accidentally, causing serious personal injury.
10. **COMPRESSED AIR RATING:** Do not connect the nailer to compressed air that exceeds 120 PSI.

! WARNING

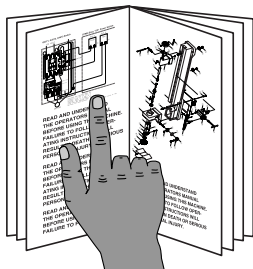

Read the manual before operation. Become familiar with this nailer, its safety instructions, and its operation before beginning any work. Serious personal injury may result if safety or operational information is not understood or followed.

! CAUTION



Never point this nailer at yourself or another person! Always pay attention to the direction this nailer is pointed. Use this tool with respect and caution to lessen the possibility of operator or bystander injury. Ignoring this warning may result in serious personal injury.

! WARNING

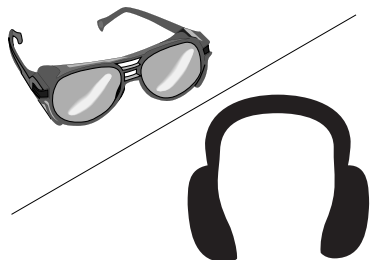

Operating this nailer can propel objects into the air, causing immediate eye damage. To protect yourself, always wear American National Standards Institute (ANSI) approved safety glasses or goggles when operating this equipment. In addition, this nailer discharges at up to 85-90 decibels. To protect your hearing, always wear ANSI approved ear protection when operating this nailer.

! CAUTION

Nailer accidents routinely happen while moving the gun to another location, such as up ladders, to another room, or even another job site. Always disconnect the gun immediately after use and never transport the gun while connected to the air—even if the air compressor is disconnected from its power source!

! CAUTION

No list of safety guidelines can be complete. Every shop environment is different. Always consider safety first, as it applies to your individual working conditions. Use this and other tools with caution and respect. Failure to do so could result in serious personal injury, damage to equipment or poor work results.

INTRODUCTION

Foreword

We are proud to offer the Grizzly Model T20644 34° Angle Finish Nailer—2½". This model is part of a growing Grizzly family of fine pneumatic tools. When used according to the guidelines set forth in this manual, you can expect years of trouble-free, enjoyable operation and proof of Grizzly's commitment to customer satisfaction.

The specifications, details, and photographs in this manual represent the Model T20644 as supplied when the manual was prepared. However, owing to Grizzly's policy of continuous improvement, changes may be made at any time with no obligation on the part of Grizzly.

Functional Description

The Model T20644 is designed to toenail into corners and shoot at any angle. This nailer is ideal for door, window, exterior, and decorative trim, cabinet work, and finish paneling. The Model T20644 features a 360° exhaust port, comfort grip rubber handle, economical air consumption with low noise, narrow nose for tight spots, and quick jam release mechanism.

Contact Info

If you have any comments regarding this manual, please contact us:

Grizzly Industrial, Inc.
C/O Technical Documentation Manager
P.O. Box 2069
Bellingham, WA 98227-2069
Email: manuals@grizzly.com

Most importantly, we stand behind our tools. If you have any service questions or parts requests, please call or write us at the location listed below.

Grizzly Industrial, Inc.
1203 Lycoming Mall Circle
Muncy, PA 17756
Phone: (570) 546-9663
Fax: (800) 438-5901
E-Mail: techsupport@grizzly.com
Web Site: <http://www.grizzly.com>

Nailer Specifications

Nail Size 15 gauge finish nails
Nail Length 1¼"-2½"
Magazine Capacity 80
Air Inlet ¼" NPT
Weight 5 lbs.
Operating Pressure 60-100 PSI
Max Operating Pressure 120 PSI

SETUP

Unpacking

Your Model T20644 left our warehouse in a carefully packed box. If you discover the nailer is damaged after you have signed for delivery, *please immediately call Customer Service at (570) 546-9663 for advice.*

Save the containers and all packing materials for possible inspection by the shipping company. (Otherwise, filing a claim can be difficult.) When you are completely satisfied with the condition of the shipment, inventory the equipment.

Inventory

After you remove the nailer case from the box you should find the following.

Model T20644 Inventory (Figure 1)

- A. 34° Finish Nailer—2½" 1
- B. Safety Goggles 1
- C. Oil..... 1
- D. Hex Wrench 3, 4, 5mm..... 1 Each
- E. Case..... 1

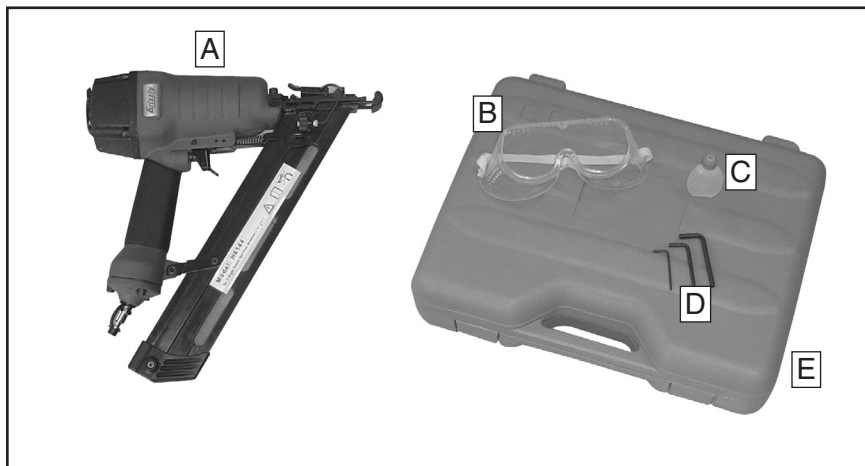

Figure 1. Model T20644 inventory.

Compressed Air System

The Model T20644 is designed to be operated at 60-100 PSI using clean, dry, regulated, compressed air. **DO NOT exceed the 120 PSI maximum operating pressure for your model.**

Before using your new nailer, regulate the air pressure to find the optimum setting within the specified operating range. Start by testing the nailer at a low setting, then increase the air pressure as needed for satisfactory results.

An in-line filter/lubricator/regulator unit can be installed, as depicted in **Figure 2**.

This filter/lubricator/regulator unit will protect your tool from damaging water build-up, allow you to adjust and maintain constant air pressure to your tool, and save you the inconvenience of having to manually lubricate your tool every time you use it.

⚠ WARNING

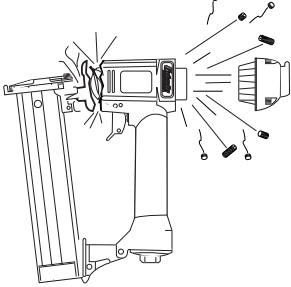

Exceeding the maximum permissible operating pressure may damage the nailer and cause it to malfunction. To reduce your risk of personal injury, DO NOT allow the air pressure to exceed the recommended pressure for this nailer!

Check the current Grizzly catalog for availability of this unit. If you plan on installing a filter/lubricator/regulator unit in your compressed air system, always follow the connection instructions that come with the unit.

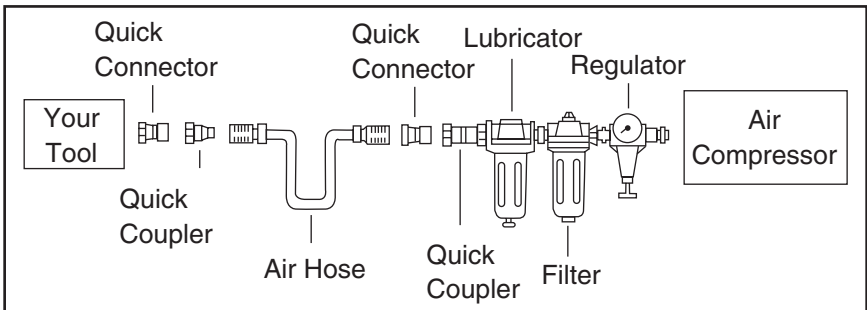

Safety Yoke

A safety yoke mechanism on the nose of the nailer acts as a secondary safety device. When the trigger is pressed, the nailer will not fire until the safety yoke mechanism is depressed.

Before you use your nailer for the first time, check the safety yoke mechanism to ensure proper function. To do this:

1. DISCONNECT NAILER FROM THE AIR SUPPLY!
2. Make sure the magazine is empty and contains no nails.
3. Make sure the trigger and the safety yoke mechanism move up and down without sticking.
4. Connect the nailer to the air supply.

WARNING

The safety yoke is a mechanical device that can fail. Never rely on the safety yoke mechanism as an excuse to point the nailer at yourself or any bystanders. Serious injury may occur.

5. Without pressing the trigger, depress the safety yoke mechanism against a scrap piece of wood that is clean and free of any knots, nails, or other foreign objects.

- If the nailer **does not fire**, then the safety yoke mechanism is working correctly.
- If the nailer **does fire** when you do this, immediately disconnect the nailer from the air supply and call Grizzly Technical Support at (570) 546-9663 for help.
- If the nailer fires when the trigger is pulled without the safety yoke mechanism being depressed, then the nailer is not working properly.
- If either of these conditions develop after you have used your nailer for a period of time, check the lubrication of these mechanisms.

WARNING

DO NOT attempt to modify or bypass the safety yoke mechanism to make the nailer fire without pushing the safety yoke down.

OPERATIONS

Loading

When replacing nails in your Model T20644, follow these guidelines:

Gauge:..... 15
Length:..... 1¼" -2½"
Capacity:.....80
Angle:34°

Note: A number of manufacturers' nails may fit the Model T20644. However, for best performance, we recommend you use the following Grizzly nails:

G6085-G6088, G9545, G6090, G3693-G3697.

To load your nailer:

1. DISCONNECT NAILER FROM THE AIR SUPPLY!
2. Insert a nail stick into the T-slot at the top of the magazine as shown in **Figure 3**.
- 3.

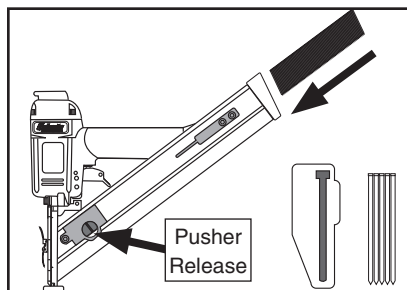

Figure 3. Loading finish nails into nailer.

3. Slide the nail stick all the way down to the nose of the nailer.
4. Pull the magazine pusher all the way back, then let it come forward until it rests against the end of the nail stick.

Operating

If you have not read the safety instructions in this manual, do not operate the nailer.

Before you operate your nailer, place one drop of the included oil into the quick connect fitting where the nailer connects to the air supply.

To operate your nailer:

1. Connect the nailer to the air supply.
2. To test for proper nail penetration, hold the nailer perpendicular to the surface of a piece of clean scrap wood that is thick enough for the length of nails you have loaded.
3. Depress the safety yoke mechanism on your workpiece.
4. Before pulling the trigger, make sure your free hand and other body parts are positioned out of the way of a potential path of a nail in case of deflection.

Deflection is caused when grain irregularities, knots or foreign objects inside the wood cause the nail to change its path, resulting in the nail puncturing the surface of the workpiece, as shown in **Figure 4**.

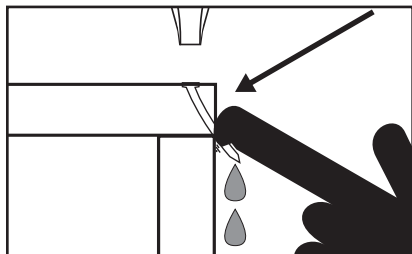

Figure 4. Example of nail deflection.

Besides damaging your workpiece, deflection can cause injury if your free hand is securing the workpiece in the location that the nail deflects.

5. Pull the trigger. If the nail drives into the wood far enough, continue with your intended operations. If the nail goes too far or not far enough, adjust the depth adjustment knob described in the **Adjusting Depth** section.

Adjusting Depth

The Model T20644 features a knurled adjustment knob (**Figure 5**) for setting the nail depth into the workpiece.

Rotate this knob to adjust the workpiece. To find the correct nail penetration depth, use trial-and-error on a scrap workpiece of the same type of material as your work.



Figure 5. Depth adjustment knob.

Clearing Jammed Nails

All nailers occasionally get jammed.

To clear a jammed nail from the discharge area on the Model T20644:

1. DISCONNECT NAILER FROM THE AIR SUPPLY!

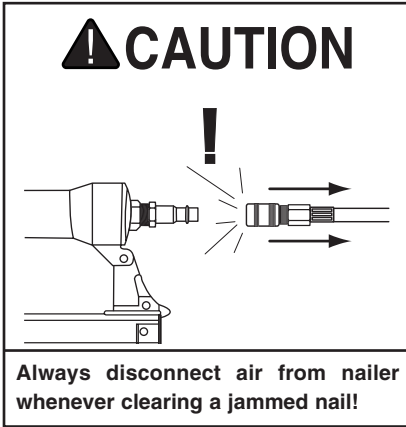

2. Release the magazine pusher and slide the nail stick out of the back of the magazine.

3. Flip up the quick release latch located on top of the nailer nose assembly, as shown in **Figure 6**.

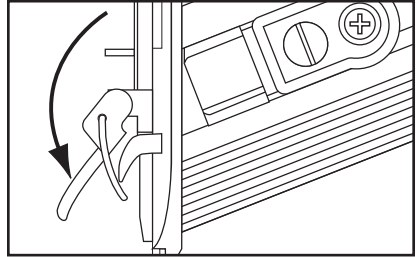

Figure 6. Releasing quick release latch.

4. Remove the driver guide cover (**Figure 7**).

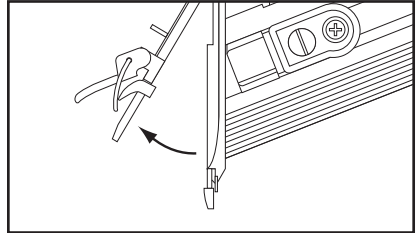

Figure 7. Removing driver guide cover.

5. The jammed nail should now be visible; remove it from the discharge area with needle nose pliers.
6. Replace the driver guide cover and snap the quick release latch back into operating position.

Replacing Pistons/ O-Rings

Repair pistons are cheap insurance in the event that a piston or piston shaft becomes worn out.

The part number for the repair piston for this nailer is #PT20644098. To order, call Customer Service at (800) 527-4777.

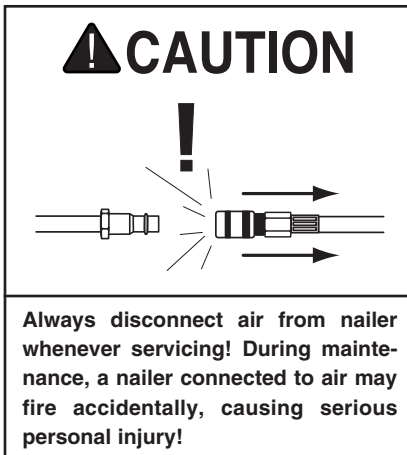

To replace a piston:

1. DISCONNECT NAILER FROM THE AIR SUPPLY!
2. Remove all nails from the magazine.
3. Remove the four cap screws on the top of the nailer, near the exhaust port.
4. Remove the top cap.
5. The top of the piston should now be visible inside the cylinder, which is housed in the head of the nailer.

6. Open the magazine.
7. Watch the discharge area and push the top of the piston with your finger. You will see the piston shaft slide down the discharge area.
8. With a long flathead screwdriver or similarly shaped tool, push the piston shaft back inside the nailer until you can grip the piston head and remove it from the cylinder. (Be careful not to scratch the discharge area when pushing the piston shaft with the screwdriver.)
9. Place a new O-ring on the new piston and apply a thin film of the nailer lubricating oil on the O-ring.
10. Insert the new piston in the cylinder. Make sure that the grooves on the piston shaft line up with those on the guide at the bottom of the cylinder. The new piston should easily slide into the cylinder. **DO NOT force the piston into the cylinder!** If the piston is not easily inserted, double-check the alignment of the piston shaft with the grooves on the guide.
11. After the piston is inserted correctly, close the magazine. Replace the top cap assembly and tighten the four cap screws.
12. For more assistance, or to install a complete O-ring set, refer to **Parts Breakdown** on **Page 16**.

ACCESSORIES

H3175— $\frac{1}{4}$ " NPT Female, Quick Coupler

H3176— $\frac{1}{4}$ " NPT Male, Quick Coupler

H3177— $\frac{1}{4}$ " NPT Male, Plug

H3178— $\frac{1}{4}$ " NPT Female, Plug

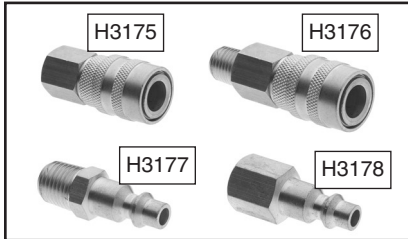

Figure 8. $\frac{1}{4}$ " NPT air fittings.

H3258—Filter/Lube/Regulator $\frac{3}{8}$ " NPT

H3259—Filter/Lube/Regulator $\frac{1}{2}$ " NPT

These units are indispensable for prolonging the lifespan of your air tools. Filter keeps water/rust out. Lubricator features adjustable automatic lubrication. Regulator allows you to control the optimum PSI delivery for each air tool. Maximum pressure for each unit is 150 PSI.



Figure 9. Models H3258 & H3259 Filter/Lubricator/Regulators.

G2820—Pneumatic Tool Oil 8 oz.

G2821—Pneumatic Tool Oil 1 Pint

Use the right oil! This pneumatic tool oil offers outstanding heat displacement and friction reduction without eating away at delicate air components like detergent motor oils. Stock up with extra bottles to avoid costly downtime.

G8114— $\frac{3}{8}$ " x 25 Ft. Air Hose

G8115— $\frac{3}{8}$ " x 50 Ft. Air Hose

G8116— $\frac{3}{8}$ " x 100 Ft. Air Hose

Multi-purpose red rubber air hose is flexible and abrasion resistant. Rated for 200 PSI, this air hose has a bursting strength of 800 PSI and $\frac{1}{4}$ " NPT ends.



Figure 10. Red rubber air hose.

H3275— $\frac{1}{4}$ " x 25' Recoil Air Hose

H3275— $\frac{1}{4}$ " x 50' Recoil Air Hose

These recoil air hoses are ideal for nailers and staplers because they are light weight and offer maneuverability in tight places that is unmatched by rubber hoses. Coiled springs protect the ends from kinking. (Prices are less than you'll spend on lunch!)

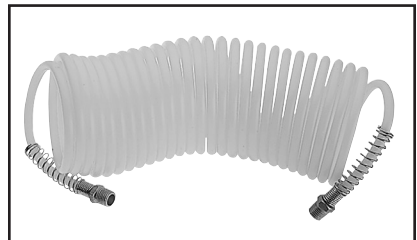

Figure 11. Recoil air hose.

Call 1-800-523-4777 To Order

CLEANING & LUBRICATION

Cleaning

Use non-flammable solvent to clean the nose assembly of the nailer. Always be sure that the nailer is dry before using it again.

Do not allow dust, chips, sand, etc. into the air connectors or into the body of the nailer; this may result in leaks and damage to the nailer and the air couplings.



Lubricating

Standard pneumatic tool oil has been included with your new Grizzly nailer to help maintain its useful life. Place two to six drops of oil in the nailer air inlet (as shown in **Figure 12**) before every use, or after 2 hours of continuous use.

Wipe off any excess oil near the nailer exhaust to avoid dust build-up. When the oil that was included with the nailer has been completely used, replace with Grizzly Model G2820 Pneumatic Tool Oil.

Another option to manual oiling would be to install a lubricator in your air compressor line. If your air compressor line already has a lubricator, then regular lubrication of your nailer will not be necessary. Just make sure there is always oil in the lubricator.

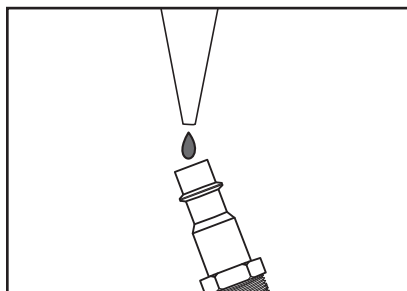
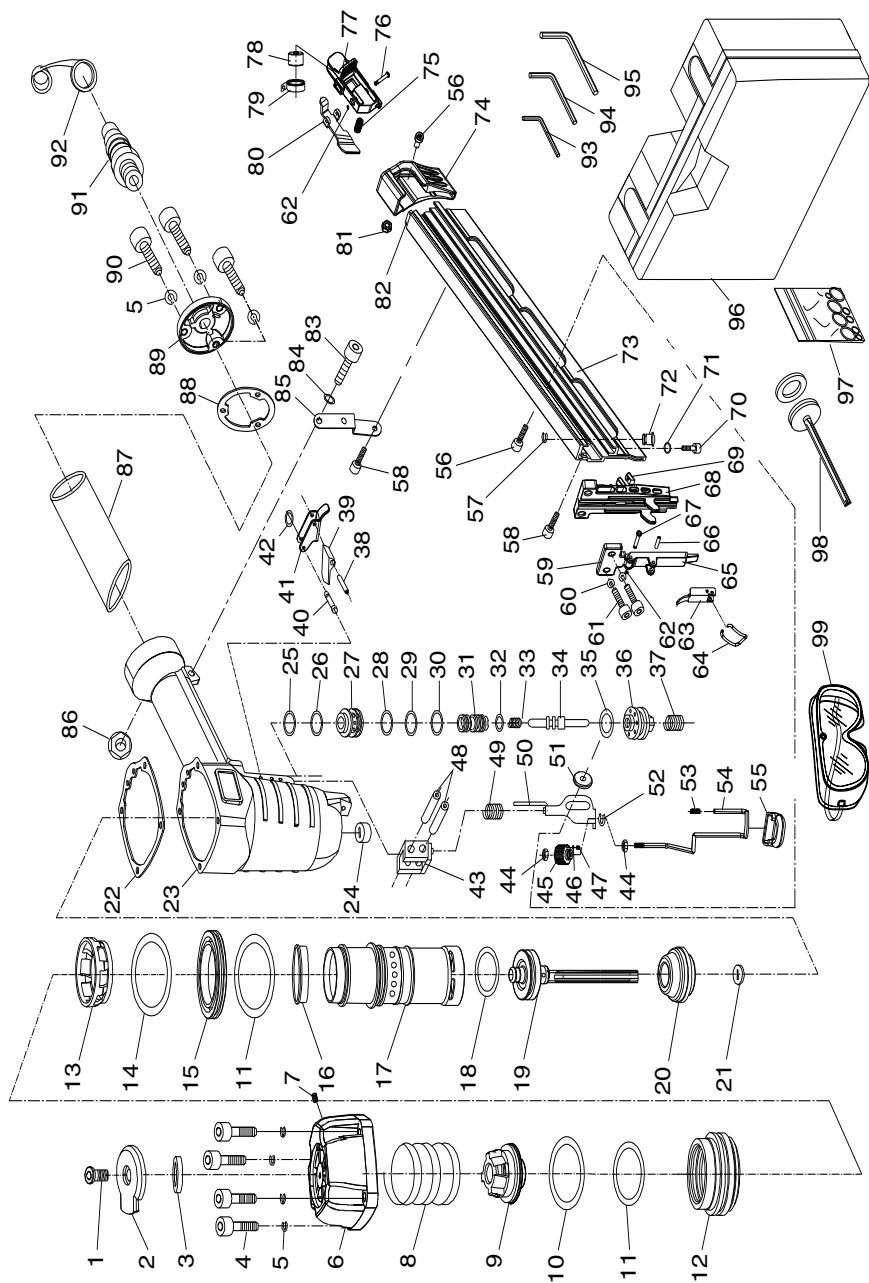

Figure 12. Lubricating nailer via air inlet.

PARTS BREAKDOWN



PARTS LIST

REF	PART #	DESCRIPTION
1	PT20644001	SPECIAL CAP SCREW
2	PT20644002	AIR DEFLECTOR
3	PT20644003	RUBBER WASHER
4	PSB38M	CAP SCREW M5-.8 X 25
5	PLW01M	LOCK WASHER 5MM
6	PT20644006	CYLINDER COVER
7	PSS79M	SET SCREW M4-.7 x 6
8	PT20644008	COMPRESSION SPRING
9	PT20644009	SWITCH VALVE SEAT
10	PORG030	O-RING 29.4 X 3.1 G30
11	PORG045	O-RING 44.4 X 3.1 G45
12	PT20644012	SWITCH VALVE
13	PT20644013	COLLAR
14	PORG065	O-RING 64.4 X 3.1 G65
15	PT20644015	FIXED RING
16	PT20644016	SEALING WASHER
17	PT20644017	CYLINDER
18	PORP035	O-RING 34.7 X 3.5 P35
19	PT20644019	PISTON
20	PT20644020	BUMPER
21	PT20644021	GUIDE
22	PT20644022	GASKET
23	PT20644023	GUN BODY
24	PT20644024	RUBBER WASHER
25	PT20644025	O-RING 15 X 2.65
26	PORS018	O-RING 17.5 X 1.5 S18
27	PT20644027	TRIGGER VALVE SEAT
28	PH7665031	O-RING 6.2 X 1.8
29	PH7665032	O-RING 6.4 X 2
30	PH7665033	O-RING 9 X 1.8
31	PT20644031	TRIGGER VALVE GUIDE
32	PH7665036	O-RING 2.5 X 1.5
33	PT20644033	SWITCH VALVE SPRING
34	PT20644034	SWITCH VALVE STEM
35	PH7665037	O-RING 20.3 X 2.3
36	PT20644036	TRIGGER VALVE SEAT
37	PT20644037	COMPRESSION SPRING
38	PRP02M	ROLL PIN 3 X 16
39	PT20644039	SAFETY SPACER
40	PT20644040	PIN
41	PT20644041	TRIGGER
42	PT20644042	O-RING 1.7 X 2
43	PT20644043	SAFETY SEAT
44	PN04M	HEX NUT M4-.7
45	PT20644045	ADJUSTING NUT
46	PT20644046	STEEL BALL 2MM
47	PT20644047	COMPRESSION SPRING
48	PRP97M	ROLL PIN 3 X 30
49	PT20644049	COMPRESSION SPRING
50	PT20644050	DRIVE STAND

REF	PART #	DESCRIPTION
51	PT20644051	SPACER
52	PEC09M	E-CLIP 6MM
53	PT20644053	COMPRESSION SPRING
54	PT20644054	SAFETY NOSE
55	PT20644055	SAFETY COVER
56	PSB17M	CAP SCREW M4-.7 x 10
57	PEC01M	E-CLIP 3MM
58	PSB18M	CAP SCREW M4-.7 x 8
59	PT20644059	FIXED COVER
60	PLW03M	LOCK WASHER 6MM
61	PSB02M	CAP SCREW M6-1 x 20
62	PT20644062	RUBBER RETAINING RING
63	PT20644063	QUICK RELEASE HANDLE
64	PT20644064	LATCH
65	PT20644065	DRIVER GUIDE COVER
66	PRP43M	ROLL PIN 3 X 22
67	PT20644067	PIN
68	PT20644068	DRIVE GUIDE
69	PT20644069	SPACER
70	PSB23M	CAP SCREW M4-.7 x 12
71	PW05M	FLAT WASHER 4MM
72	PT20644072	LOCK SCREW
73	PT20644073	MAGAZINE
74	PT20644074	FIXED SEAT
75	PT20644075	PUSHER SPRING
76	PT20644076	PUSHER PIN
77	PT20644077	PUSHER SEAT
78	PT20644078	SPRING CORE
79	PT20644079	TORSION SPRING
80	PT20644080	PUSHER
81	PN04M	HEX NUT M4-.7
82	PT20644082	DRIVE NAIL BAR
83	PSB33M	CAP SCREW M5-.8 x 12
84	PW02M	FLAT WASHER 5MM
85	PT20644085	SUPPORT SEAT
86	PFN04M	FLANGE NUT M5-.8
87	PT20644087	RUBBER HANDLE CASE
88	PT20644088	END CAP GASKET
89	PT20644089	END CAP
90	PSB53M	CAP SCREW M5-.8 x 18
91	PT20644091	MALE AIR PLUG 1/4" NPT
92	PT20644092	AIR PLUG DUST COVER
93	PAW03M	HEX WRENCH 3MM
94	PAW04M	HEX WRENCH 4MM
95	PAW05M	HEX WRENCH 5MM
96	PT20644096	CARRYING CASE
97	PT20644097	COMPLETE O-RING KIT
98	PT20644098	PISTON REPAIR KIT
99	PT20644099	SAFETY GLASSES

TROUBLESHOOTING

Symptom	Possible Cause	Solution
Air leaking at trigger valve area.	1. O-rings in trigger valve housing are damaged.	1. O-rings must be replaced & operation of safety nose must be checked.
Air leaking.	1. Loose screws in housing. 2. Damaged O-ring(s). 3. Loose air fitting. 4. Damaged housing gasket(s).	1. Tighten screws. 2. Replace O-ring(s). 3. Tighten air fitting & use teflon tape. 4. Replace gasket(s).
Tool skips nails while discharging.	1. Excessive air pressure. 2. Air leaks. 3. Dirt in nose. 4. Dirt or damage prevents nails from moving freely in magazine. 5. Inadequate air flow to tool. 6. Worn O-ring on piston or lack of lubrication. 7. Damaged O-rings on trigger valve. 8. Worn bumper. 9. Cap seal leaking.	1. Reduce air pressure to tool. 2. Tighten screws and fittings. 3. Clean nose. 4. Clean magazine and inspect/repair damage. 5. Check fitting, hose, compressor & air pressure. 6. Replace piston O-ring. Lubricate. 7. Replace trigger valve O-rings. 8. Replace bumper. 9. Replace cap seal.
Tool runs slowly or has a loss of power.	1. Undersized air hose. 2. Nailer is not lubricated. 3. Broken spring in cap assembly. 4. Exhaust port in cap is blocked. 5. Air pressure too low.	1. Use a larger air hose. 2. Lubricate nailer. 3. Replace spring. 4. Clean or replace damaged internal parts. 5. Increase air pressure.
Fasteners frequently jam the nailer.	1. Nails are the wrong size. 2. Nails are bent or dirty. 3. Magazine or nose screws are loose. 4. Driver or driver guide are worn or damaged. 5. Nails are wrong angle.	1. Use correct nails. 2. Use undamaged, clean nails. 3. Tighten magazine. 4. Replace worn or damaged parts. 5. Use correct angle nails.
Nailer does not fire.	1. Nailer is not lubricated. 2. Nail is jammed in magazine or discharge area. 3. Piston shaft is damaged. 4. Air pressure too low.	1. Lubricate nailer. 2. Clear nailer magazine or discharge area. 3. Replace piston shaft. 4. Check/increase air pressure.

WARRANTY AND RETURNS

Grizzly Industrial, Inc. warrants every product it sells for a period of **1 year** to the original purchaser from the date of purchase. This warranty does not apply to defects due directly or indirectly to misuse, abuse, negligence, accidents, repairs or alterations or lack of maintenance. This is Grizzly's sole written warranty and any and all warranties that may be implied by law, including any merchantability or fitness, for any particular purpose, are hereby limited to the duration of this written warranty. We do not warrant or represent that the merchandise complies with the provisions of any law or acts unless the manufacturer so warrants. In no event shall Grizzly's liability under this warranty exceed the purchase price paid for the product and any legal actions brought against Grizzly shall be tried in the State of Washington, County of Whatcom.

We shall in no event be liable for death, injuries to persons or property or for incidental, contingent, special, or consequential damages arising from the use of our products.

To take advantage of this warranty, contact us by mail or phone and give us all the details. We will then issue you a "Return Authorization Number," which must be clearly posted on the outside as well as the inside of the carton. We will not accept any item back without this number. Proof of purchase must accompany the merchandise.

The manufacturers reserve the right to change specifications at any time because they constantly strive to achieve better quality equipment. We make every effort to ensure that our products meet high quality and durability standards and we hope you never need to use this warranty.

Thank you again for your business and continued support. We hope to serve you again soon!