

Grizzly **Industrial, Inc.**®

MODEL G8688 MINI METAL LATHE OWNER'S MANUAL

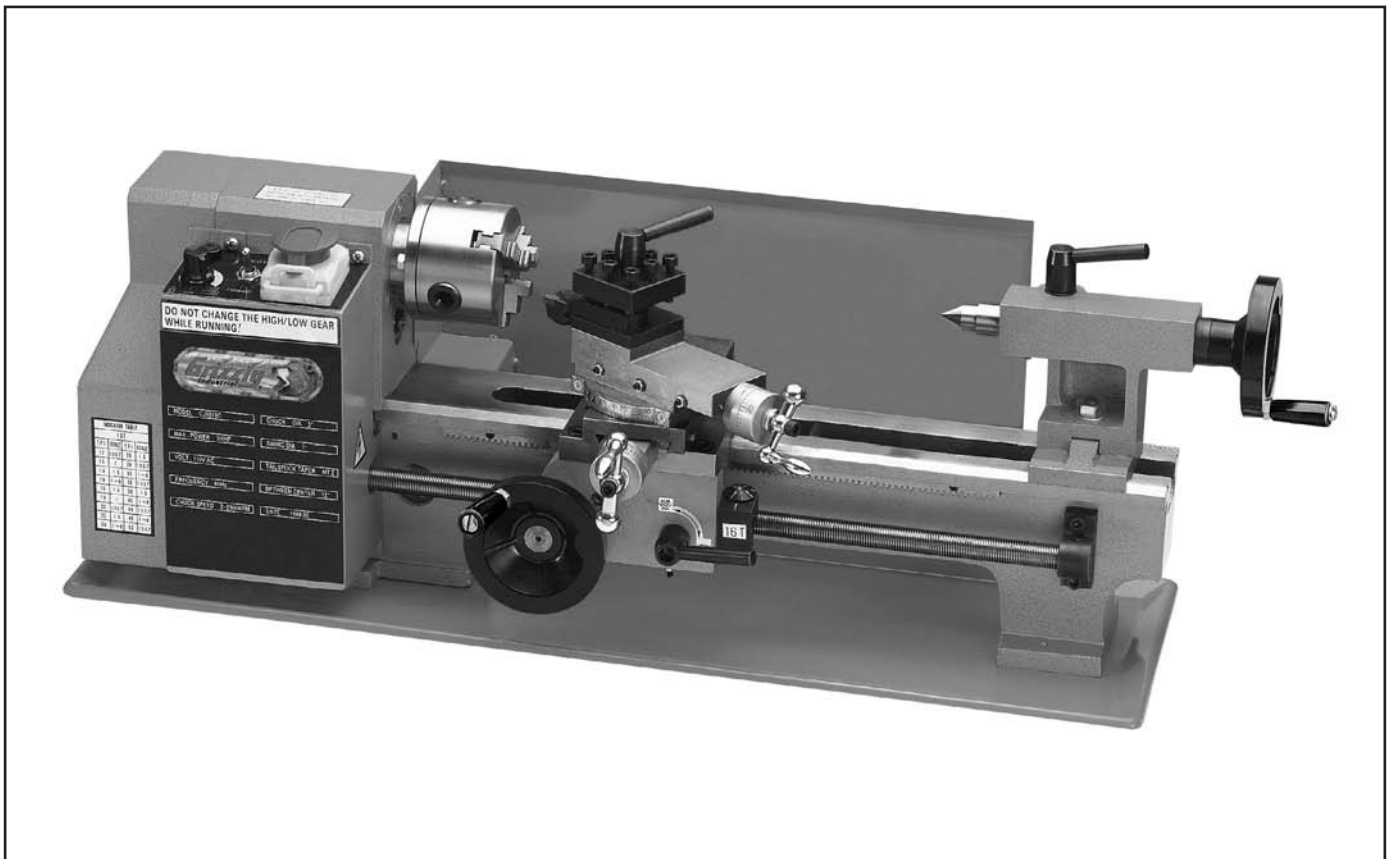

COPYRIGHT © SEPTEMBER, 2005 BY GRIZZLY INDUSTRIAL, INC., REVISED JANUARY, 2010 (TR)
**WARNING: NO PORTION OF THIS MANUAL MAY BE REPRODUCED IN ANY SHAPE
OR FORM WITHOUT THE WRITTEN APPROVAL OF GRIZZLY INDUSTRIAL, INC.**
(FOR MODELS MANUFACTURED SINCE 3/09) #PC7563 PRINTED IN CHINA

WARNING!

This manual provides critical safety instructions on the proper setup, operation, maintenance and service of this machine/equipment.

Failure to read, understand and follow the instructions given in this manual may result in serious personal injury, including amputation, electrocution or death.

The owner of this machine/equipment is solely responsible for its safe use. This responsibility includes but is not limited to proper installation in a safe environment, personnel training and usage authorization, proper inspection and maintenance, manual availability and comprehension, application of safety devices, blade/cutter integrity, and the usage of personal protective equipment.

The manufacturer will not be held liable for injury or property damage from negligence, improper training, machine modifications or misuse.

WARNING!

Some dust created by power sanding, sawing, grinding, drilling, and other construction activities contains chemicals known to the State of California to cause cancer, birth defects or other reproductive harm. Some examples of these chemicals are:

- **Lead from lead-based paints.**
- **Crystalline silica from bricks, cement and other masonry products.**
- **Arsenic and chromium from chemically-treated lumber.**

Your risk from these exposures varies, depending on how often you do this type of work. To reduce your exposure to these chemicals: Work in a well ventilated area, and work with approved safety equipment, such as those dust masks that are specially designed to filter out microscopic particles.

Table of Contents

- INTRODUCTION..... 2**
 - Manual Accuracy..... 2
 - Contact Info..... 2
 - Machine Description..... 2
 - Identification..... 3
 - Machine Data Sheet..... 4
- SECTION 1: SAFETY..... 6**
 - Safety Instructions for Machinery..... 6
 - Additional Safety for Metal Lathes..... 8
- SECTION 2: CIRCUIT REQUIREMENTS..... 9**
 - 110V Operation..... 9
- SECTION 3: SET UP..... 10**
 - Needed for Set Up..... 10
 - Unpacking..... 10
 - Inventory..... 11
 - Hardware Recognition Chart..... 12
 - Clean Up..... 13
 - Site Considerations..... 13
 - Moving & Placing Mini Lathe..... 14
 - Installing Handwheel Handles..... 15
 - Test Run..... 16
- SECTION 4: OPERATIONS..... 17**
 - Speed & Power Controls..... 17
 - Chuck Jaws..... 18
 - Replacing Chuck Jaws..... 19
 - Removing/Installing Chuck or Faceplate..... 20
 - Tailstock..... 21
 - Tailstock Positioning..... 21
 - Dead Center..... 22
 - Tool Post..... 22
 - Steady Rest..... 23
 - Cross Slide..... 24
 - Compound Slide..... 24
 - Carriage..... 25
 - Gear Charts..... 26
 - Change Gears..... 26
 - Cutting Threads..... 27
- SECTION 5: ACCESSORIES..... 28**
- SECTION 6: MAINTENANCE..... 30**
 - Schedule..... 30
 - Cleaning..... 30
 - Lubrication..... 30
- SECTION 7: SERVICE..... 31**
 - Troubleshooting..... 31
 - Adjusting Gibs..... 34
 - Replacing Motor Brushes..... 34
 - Tailstock Alignment..... 35
 - Electrical Components..... 37
 - Parts Breakdown..... 38
 - Parts List..... 39
- WARRANTY AND RETURNS..... 45**

INTRODUCTION

Manual Accuracy

We are proud to offer this manual with your new machine! We've made every effort to be exact with the instructions, specifications, drawings, and photographs of the machine we used when writing this manual. However, sometimes errors do happen and we apologize for them.

Also, owing to our policy of continuous improvement, **your machine may not exactly match the manual**. If you find this to be the case, and the difference between the manual and machine leaves you in doubt, check our website for the latest manual update or call technical support for help.

Before calling, find the manufacture date of your machine by looking at the date stamped into the machine ID label (see below). This will help us determine if the manual version you received matches the manufacture date of your machine.

		MODEL GXXXX MACHINE NAME	
SPECIFICATIONS		▲ WARNING!	
Motor:		Manufacture Date of Your Machine	ing this machine: operation. s and respirator. sted/setup and suit before starting.
Specification:			
Specification:			
Specification:			
Weight:			
<input type="text"/>	Date		
<input type="text"/>	Serial Number		
Manufactured for Grizzly in Taiwan			
		4. make sure the motor has stopped and disconnect power before adjustments, maintenance, or service.	
		5. DO NOT expose to rain or dampness.	
		6. DO NOT modify this machine in any way.	
		7. DO NOT remove safety guards.	
		8. Never leave machine running unattended.	
		9. DO NOT operate under the influence of drugs or alcohol.	
		10. Maintain machine carefully to prevent accidents.	

For your convenience, we post all available manuals and manual updates for free on our website at www.grizzly.com. Any updates to your model of machine will be reflected in these documents as soon as they are complete.

Contact Info

We stand behind our machines. If you have any service questions, parts requests or general questions about the machine, please call or write us at the location listed below.

Grizzly Industrial, Inc.
1203 Lycoming Mall Circle
Muncy, PA 17756
Phone: (570) 546-9663
Fax: (800) 438-5901
E-Mail: techsupport@grizzly.com

If you have any comments regarding this manual, please write to us at the address below:

Grizzly Industrial, Inc.
c/o Technical Documentation Manager
P.O. Box 2069
Bellingham, WA 98227-2069
Email: manuals@grizzly.com

Machine Description

The metal lathe is used to remove material from a rotating workpiece, which is held in place on the spindle with a chuck or faceplate. The cutting tool is mounted on the carriage or tailstock and moved against the spinning workpiece to perform the cut.

Typical cutting operations for a metal lathe include facing, turning, parting, drilling, reaming, grooving, knurling, and threading. There are a wide variety of tools and workpiece holding devices available for each of these operations.



Identification

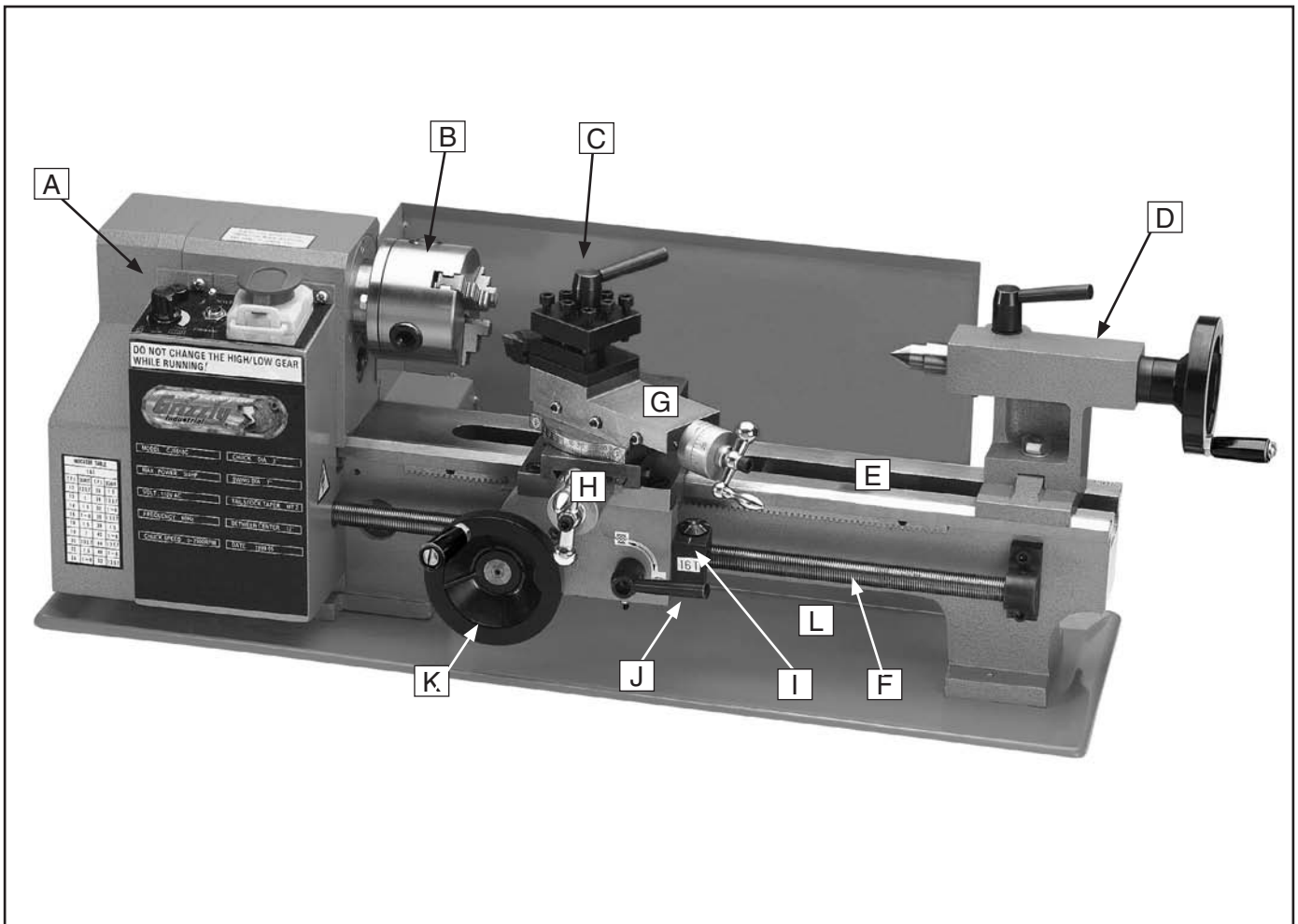

Figure 1. G8688 Identification.

- A. Control Panel
- B. Chuck
- C. Toolpost
- D. Tailstock
- E. Bedways
- F. Leadscrew
- G. Compound-Slide
- H. Cross-Slide
- I. Thread Dial Indicator
- J. Feed Lever
- K. Longitudinal Handwheel
- L. Chip Tray

NOTICE

If you have never used this type of machine or equipment before, **WE STRONGLY RECOMMEND** that you read books, trade magazines, or get formal training before beginning any projects. Regardless of the content in this section, Grizzly Industrial will not be held liable for accidents caused by lack of training.





MACHINE DATA SHEET

Customer Service #: (570) 546-9663 · To Order Call: (800) 523-4777 · Fax #: (800) 438-5901

MODEL G8688 7" X 12" MINI METAL LATHE

Product Dimensions:

Weight..... 75 lbs.
 Length/Width/Height..... 27-3/4 x 11-1/2 x 12 in.
 Foot Print (Length/Width)..... 27-3/4 x 8-3/4 in.

Shipping Dimensions:

Type..... Cardboard
 Content..... Machine
 Weight..... 90 lbs.
 Length/Width/Height..... 30 x 13 x 13 in.

Electrical:

Switch..... Forward/Reverse
 Switch Voltage..... 110V
 Cord Length..... 6 ft.
 Cord Gauge..... 14 gauge
 Minimum Circuit Size..... 10 amp
 Plug Included..... Yes

Motors:

Main

Type..... Universal Brush
 Horsepower..... 3/4 HP
 Voltage..... 110V
 Prewired..... 110V
 Phase..... Single
 Amps..... 3A
 Speed..... Variable RPM
 Cycle..... 60 Hz
 Number Of Speeds..... Variable
 Power Transfer Belt Drive to Gear
 Bearings..... Shielded and Permanently Lubricated

Main Specifications:

Operation Info

Swing Over Bed..... 7 in.
 Dist Between Centers..... 12 in.
 Swing Over Cross Slide..... 2-1/8 in.
 Swing Over Saddle..... 5 in.
 Swing Over Gap..... 7 in.
 Max Tool Bit Size..... 5/16 in.
 Compound Travel..... 2-3/4 in.
 Carriage Travel..... 10-1/2 in.
 Cross Slide Travel..... 2-3/4 in.



Headstock Info

Spindle Bore.....20 mm
Spindle Size..... 3 in.
Spindle Taper..... MT#3
No Of Spindle Speeds..... Variable
Spindle Speeds..... Low:0-1100, High:0-2500 RPM
Spindle Type..... Intrinsic Back Plate
Spindle Bearings..... Ball Bearing

Tailstock Info

Tailstock Travel..... 2-1/2 in.
Tailstock Taper..... MT#2
Tailstock Barrel Diameter..... 0.870 in.

Threading Info

No Of Inch Threads..... 18
Range Of Inch Threads..... 12 - 52 TPI
Range Of Longitudinal Feeds..... 0.04 in.
No Of Longitudinal Feeds..... 1
No Of Metric Threads..... 10
Range Of Metric Threads..... 0.4 - 2.0 mm

Dimensions

Bed Width..... 3-1/4 in.
Leadscrew TPI..... 16
Leadscrew Length..... 17-3/4 in.
Follow Rest Capacity..... 1 in.
Faceplate Size..... 6-1/4 in.
Leadscrew Diameter..... 5/8 in.
Floor To Center Height..... 8-1/2 in.

Construction

Base Construction..... Cast Iron
Headstock Construction..... Cast Iron
Headstock Gears Construction..... Plastic
Bed Construction..... Cast Iron
Body Construction..... Cast Iron
Paint..... Epoxy

Other

Kilowatt Output..... 0.559
Optional Stand..... G7313

Other Specifications:

Country Of Origin China
Warranty 1 Year
Serial Number Location Back Right End on Bed Way

Features:

- 16 TPI Reversible Leadscrew
- Chip Tray and Backsplash Guard
- Emergency Stop
- Forward and Reverse in all Speeds
- Inch/Metric Dials
- Threading Dial Indicator
- Variable Speed



SECTION 1: SAFETY

WARNING

For Your Own Safety, Read Instruction Manual Before Operating this Machine

The purpose of safety symbols is to attract your attention to possible hazardous conditions. This manual uses a series of symbols and signal words which are intended to convey the level of importance of the safety messages. The progression of symbols is described below. Remember that safety messages by themselves do not eliminate danger and are not a substitute for proper accident prevention measures.

 **DANGER** Indicates an imminently hazardous situation which, if not avoided, **WILL** result in death or serious injury.

 **WARNING** Indicates a potentially hazardous situation which, if not avoided, **COULD** result in death or serious injury.

 **CAUTION** Indicates a potentially hazardous situation which, if not avoided, **MAY** result in minor or moderate injury. It may also be used to alert against unsafe practices.

NOTICE This symbol is used to alert the user to useful information about proper operation of the machine.

WARNING

Safety Instructions for Machinery

- 1. READ THROUGH THE ENTIRE MANUAL BEFORE STARTING MACHINERY.** Machinery presents serious injury hazards to untrained users.
- 2. ALWAYS USE ANSI APPROVED SAFETY GLASSES WHEN OPERATING MACHINERY.** Everyday eyeglasses only have impact resistant lenses, they are NOT safety glasses.
- 3. ALWAYS WEAR AN ANSI APPROVED RESPIRATOR WHEN OPERATING MACHINERY THAT PRODUCES DUST.** Wood dust is a carcinogen and can cause cancer and severe respiratory illnesses.
- 4. ALWAYS USE HEARING PROTECTION WHEN OPERATING MACHINERY.** Machinery noise can cause permanent hearing damage.
- 5. WEAR PROPER APPAREL. DO NOT** wear loose clothing, gloves, neckties, rings, or jewelry which may get caught in moving parts. Wear protective hair covering to contain long hair and wear non-slip footwear.
- 6. NEVER OPERATE MACHINERY WHEN TIRED, OR UNDER THE INFLUENCE OF DRUGS OR ALCOHOL.** Be mentally alert at all times when running machinery.



WARNING

Safety Instructions for Machinery

7. **ONLY ALLOW TRAINED AND PROPERLY SUPERVISED PERSONNEL TO OPERATE MACHINERY.** Make sure operation instructions are safe and clearly understood.
8. **KEEP CHILDREN AND VISITORS AWAY.** Keep all children and visitors a safe distance from the work area.
9. **MAKE WORKSHOP CHILD PROOF.** Use padlocks, master switches, and remove start switch keys.
10. **NEVER LEAVE WHEN MACHINE IS RUNNING.** Turn power **OFF** and allow all moving parts to come to a complete stop before leaving machine unattended.
11. **DO NOT USE IN DANGEROUS ENVIRONMENTS.** DO NOT use machinery in damp, wet locations, or where any flammable or noxious fumes may exist.
12. **KEEP WORK AREA CLEAN AND WELL LIT.** Clutter and dark shadows may cause accidents.
13. **USE A GROUNDED EXTENSION CORD RATED FOR THE MACHINE AMPERAGE.** Undersized cords overheat and lose power. Replace extension cords if they become damaged. DO NOT use extension cords for 220V machinery.
14. **ALWAYS DISCONNECT FROM POWER SOURCE BEFORE SERVICING MACHINERY.** Make sure switch is in OFF position before reconnecting.
15. **MAINTAIN MACHINERY WITH CARE.** Keep blades sharp and clean for best and safest performance. Follow instructions for lubricating and changing accessories.
16. **MAKE SURE GUARDS ARE IN PLACE AND WORK CORRECTLY BEFORE USING MACHINERY.**
17. **REMOVE ADJUSTING KEYS AND WRENCHES.** Make a habit of checking for keys and adjusting wrenches before turning machinery **ON**.
18. **CHECK FOR DAMAGED PARTS BEFORE USING MACHINERY.** Check for binding and alignment of parts, broken parts, part mounting, loose bolts, and any other conditions that may affect machine operation. Repair or replace damaged parts.
19. **USE RECOMMENDED ACCESSORIES.** Refer to the instruction manual for recommended accessories. The use of improper accessories may cause risk of injury.
20. **DO NOT FORCE MACHINERY.** Work at the speed for which the machine or accessory was designed.
21. **SECURE WORKPIECE.** Use clamps or a vise to hold the workpiece when practical. A secured workpiece protects your hands and frees both hands to operate the machine.
22. **DO NOT OVERREACH.** Keep proper footing and balance at all times.
23. **MANY MACHINES WILL EJECT THE WORKPIECE TOWARD THE OPERATOR.** Know and avoid conditions that cause the workpiece to "kickback."
24. **ALWAYS LOCK MOBILE BASES (IF USED) BEFORE OPERATING MACHINERY.**
25. **BE AWARE THAT CERTAIN MATERIALS MAY CAUSE AN ALLERGIC REACTION** in people and animals, especially when exposed to fine dust. Make sure you know what type of dust you will be exposed to and always wear an approved respirator.



WARNING

Additional Safety for Metal Lathes

- 1. READ AND UNDERSTAND THIS MANUAL BEFORE OPERATING THIS MACHINE. YOUR SAFETY AND THE PROPER USE OF THIS MACHINE IS YOUR RESPONSIBILITY.**
- 2. CLEARING CHIPS.** Do not clear chips by hand. Use a brush, and never clear chips while the lathe is turning.
- 3. CHUCK KEY SAFETY.** Always remove chuck key. Never walk away from the lathe with the key in the chuck.
- 4. TOOL SELECTION.** Always select the right cutter for the job, and make sure they are sharp. The right tool decreases strain on the lathe components and provides a better finish.
- 5. SECURING THE WORKPIECE.** Make sure workpiece is properly held in chuck before starting lathe. A workpiece thrown from the chuck will severely injure you or a bystander.
- 6. SUPPORT LONG STOCK.** Stock extending beyond the headstock **MUST** be supported. Unsupported stock will begin to whip and cause serious injury to operator, bystanders and cause damage to the lathe. Always turn supported long stock at slow RPM's.
- 7. INSTALLING LARGE CHUCKS.** Get assistance when installing large chucks. Large lathe chucks are very heavy and sometimes awkward to hold.
- 8. PINCH HAZARDS.** Protect your hands and the precision ground ways. Always use a chuck cradle or piece of plywood over the ways of the lathe when servicing chucks.
- 9. LATHE MAINTENANCE.** Never operate the lathe with damaged or worn parts.
- 10. SAFETY CLEARANCES.** Make sure workpiece has adequate clearance before starting machine. Check tool and tool post clearance, chuck clearance, and saddle clearance before starting the lathe.
- 11. PROPER FEED RATES.** Always use the appropriate feed and speed rates.
- 12. STOPPING LATHE.** Never attempt to slow or stop the lathe chuck by using your hand.
- 13. ATTENDANCE.** Never walk away while the lathe is running. An unsupervised lathe that is running invites accidents.
- 14. LONG HAIR.** Tie up long hair. Long hair down in a ponytail still poses a risk of entanglement with moving parts.
- 15. AUTOMATIC FEEDS.** Release any automatic feeds after completing a job.
- 16. TURNING SPEEDS.** Select the turning speed which is appropriate for the type of work, material, and tool bit. Allow the lathe to gain its full speed before beginning a cut.
- 17. MOTOR DIRECTION.** Never reverse motor direction while the lathe is in motion.
- 18. GUARDS.** You must make sure all guards are in place and working properly.
- 19. TOOL POST CLEARANCE.** Adjust tool post to provide proper support for the turning tool you will be using. Test tool post clearance by rotating workpiece by hand before turning lathe **ON**.
- 20. CRASHES.** Make sure no part of the tool, tool holder, compound slide, cross slide, or carriage will contact the chuck during operation.



SECTION 2: CIRCUIT REQUIREMENTS

110V Operation

!WARNING

Serious personal injury could occur if you connect the machine to power before completing the setup process. **DO NOT** connect the machine to the power until instructed later in this manual.



!WARNING

Electrocution or fire could result if machine is not grounded and installed in compliance with electrical codes. Compliance **MUST** be verified by a qualified electrician!

Full Load Amperage Draw

This machine draws the following amps:

Amp Draw..... 3 Amps

Power Supply Circuit Requirements

The power supply circuit for your machine **MUST** be grounded and rated for the amperage given below. Never replace a circuit breaker on an existing circuit with one of higher amperage without consulting a qualified electrician to ensure compliance with wiring codes. **If you are unsure about the wiring codes in your area or you plan to connect your machine to a shared circuit, consult a qualified electrician.**

Minimum Circuit Size..... 15 Amps

Power Connection Device

This machine comes with a plug, similar to **Figure 2**, to connect the machine to power.

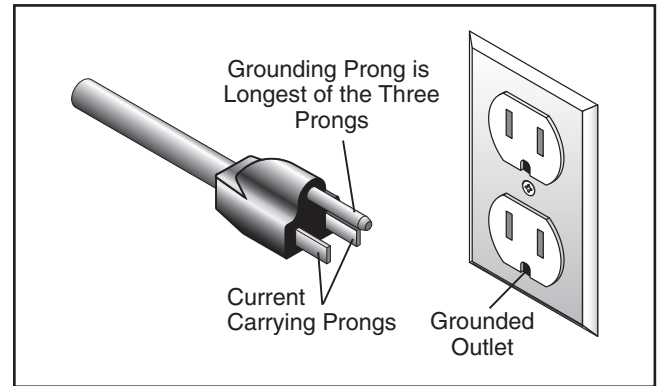
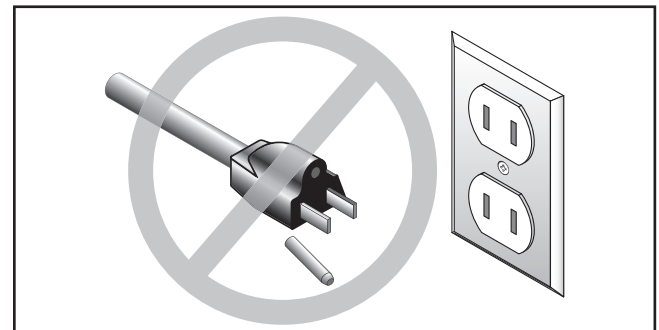

Figure 2. Typical 5-15 plug and receptacle.



!CAUTION

This machine **MUST** have a ground prong in the plug to help ensure that it is grounded. **DO NOT** remove ground prong from plug to fit into a two-pronged outlet! If the plug will not fit the outlet, have the proper outlet installed by a qualified electrician.

Extension Cords

We do not recommend using extension cords, but if you find it absolutely necessary:

- Use at least a 14 gauge cord that does not exceed 50 feet in length!
- The extension cord must have a ground wire and plug pin.
- A qualified electrician **MUST** size cords over 50 feet long to prevent motor damage.



Inventory

After all the parts have been removed from the two boxes, you should have the following items:

Box 1: (Figures 3 & 4)	Qty
A. Model G8688 Mini Lathe.....	1
B. Lathe Dog.....	1
C. Hex Wrenches 3, 4, & 5mm	1 ea.
D. Chuck Key	1
E. Oil Container	1
F. Handwheel Handles	2
G. Open End Wrench 8/10mm.....	1
H. Open End Wrench 14/17mm	1
I. Dead Center MT#2.....	1
J. External Jaws for 3-Jaw Chuck.....	3
K. Plastic Gear Set 65, 60, 57, 55, 50, 45, 40 (Qty 2), 35, & 30 Tooth.....	1 ea.
L. Steady Rest.....	1
M. Faceplate 160mm.....	1
N. Brackets with Rubber Feet.....	2
O. Spare Fuse.....	1

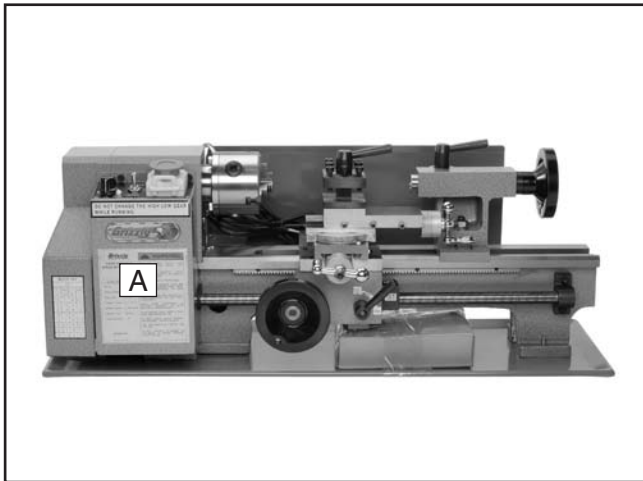

Figure 3. Model 8688 Mini Lathe.

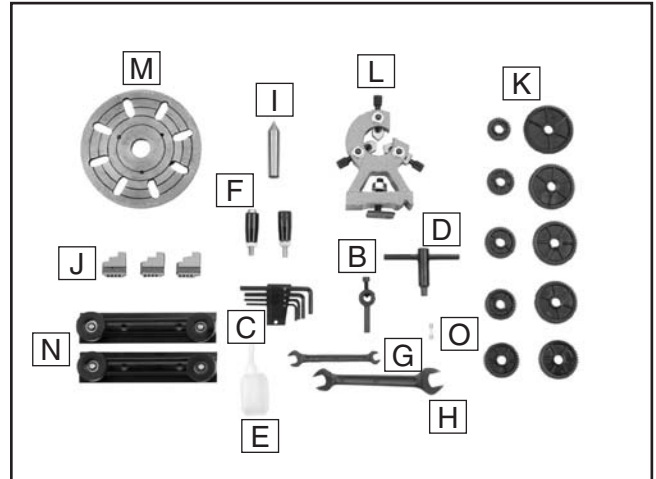

Figure 4. Model G8688 Inventory.

In the event that any nonproprietary parts are missing (e.g. a nut or a washer), we would be glad to replace them, or for the sake of expediency, replacements can be obtained at your local hardware store.



Hardware Recognition Chart

USE THIS CHART TO MATCH UP HARDWARE DURING THE ASSEMBLY PROCESS.

MEASURE BOLT DIAMETER BY PLACING INSIDE CIRCLE

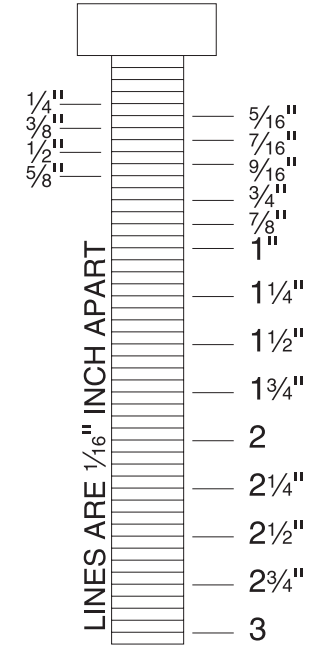
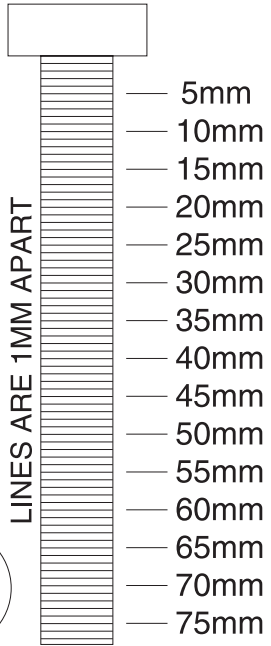
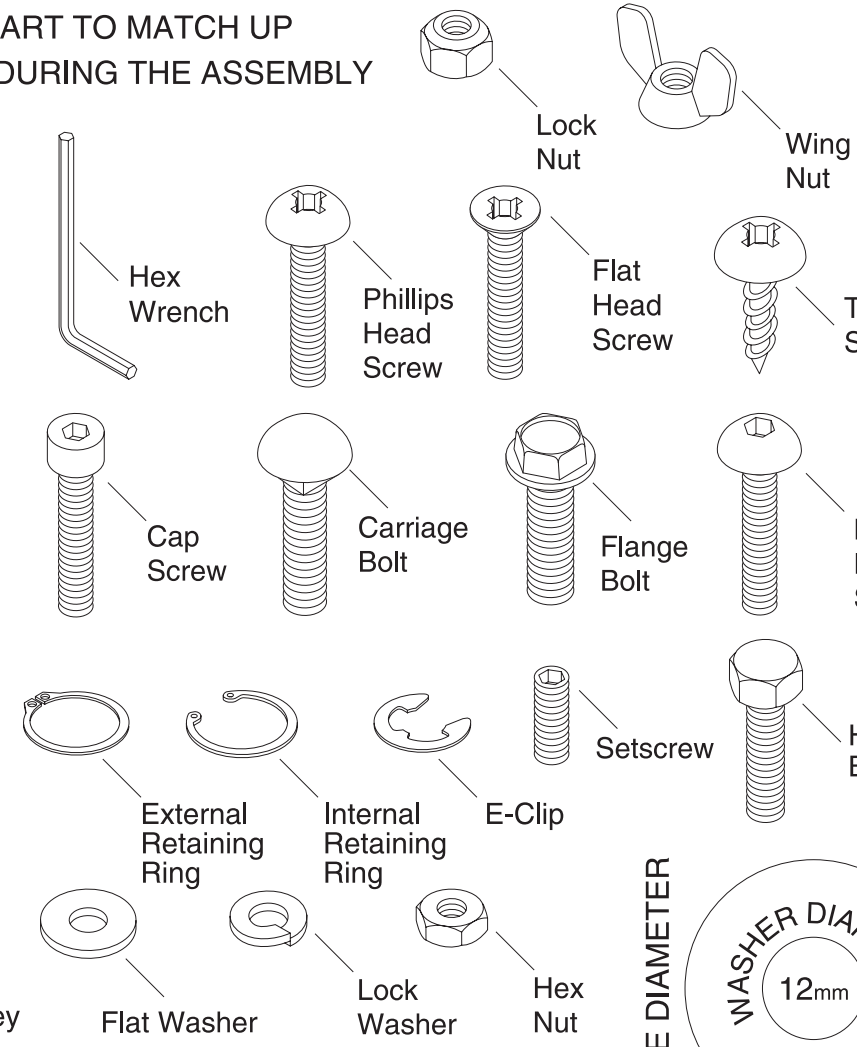
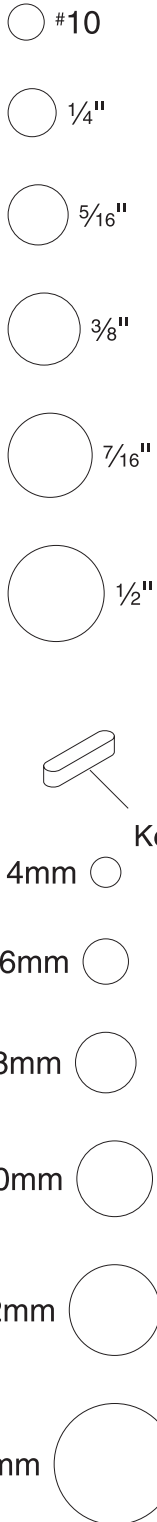

WASHERS ARE MEASURED BY THE INSIDE DIAMETER

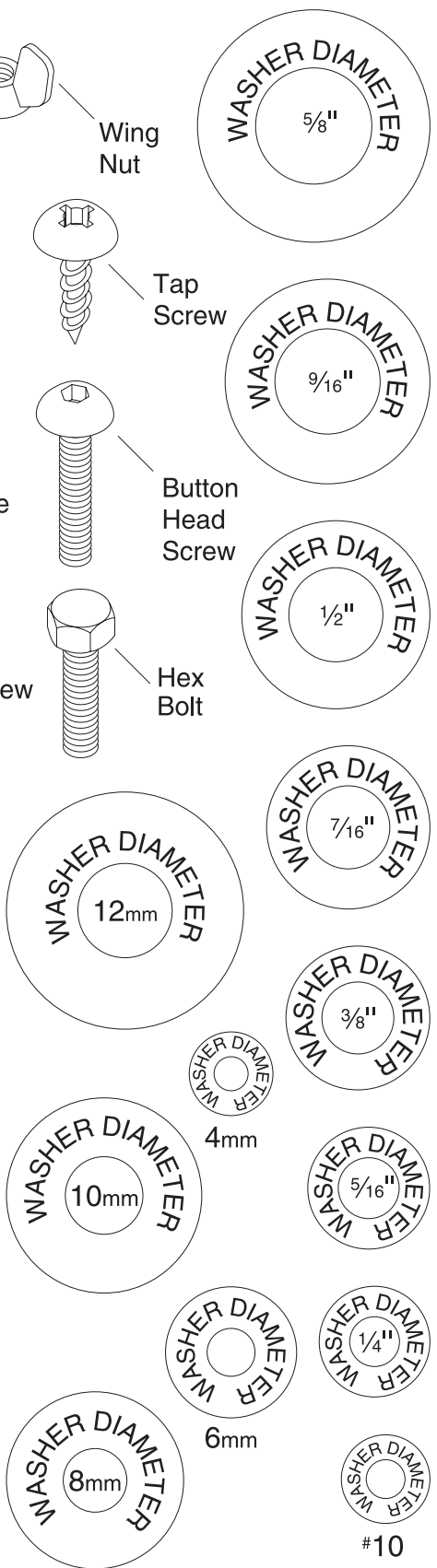

Clean Up

The unpainted surfaces are coated with a waxy oil to prevent corrosion during shipment. Remove this protective coating with a solvent cleaner or degreaser, such as shown in **Figure 5**. For thorough cleaning, some parts must be removed. **For optimum performance, clean all moving parts or sliding contact surfaces.** Avoid chlorine-based solvents, such as acetone or brake parts cleaner that may damage painted surfaces. Always follow the manufacturer's instructions when using any type of cleaning product.

	<p>! WARNING Gasoline and petroleum products have low flash points and can explode or cause fire if used to clean machinery. DO NOT use these products to clean the machinery.</p>
---	--

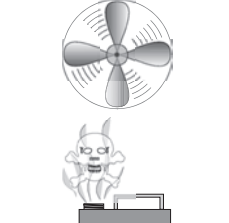
	<p>! CAUTION Many cleaning solvents are toxic if inhaled. Minimize your risk by only using these products in a well ventilated area.</p>
---	---

G2544—Solvent Cleaner & Degreaser
H9692—Orange Power Degreaser
Great products for removing shipping grease.

<p>Call 1-800-523-4777 To Order</p>	
--	---

Figure 5. Cleaner/degreasers available from Grizzly.

Site Considerations

Workbench Load

Refer to the **Machine Data Sheet** for the weight and footprint specifications of your machine. Some workbenches may require additional reinforcement to support both the machine and material.

Working Clearances

Consider existing and anticipated needs, size of material to be processed through each machine, and space for auxiliary stands, work tables or other machinery when establishing a location for your new machine. See **Figure 6** for the minimum working clearances.

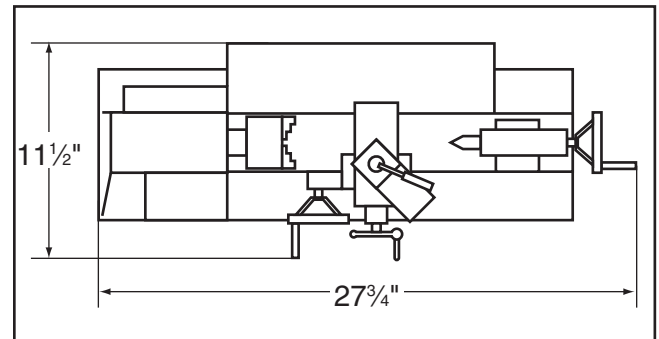
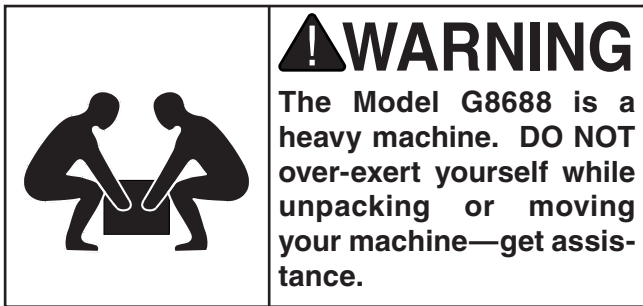

Figure 6. Minimum working clearances.

	<p>! CAUTION Unsupervised children and visitors inside your shop could cause serious personal injury to themselves. Lock all entrances to the shop when you are away and DO NOT allow unsupervised children or visitors in your shop at any time!</p>
--	---



Moving & Placing Mini Lathe



The lathe should be mounted or placed on a strong well lit workbench of sufficient height so that you do not need to bend your back to perform normal operations.

To bolt the lathe to your workbench:

1. Remove the four M6-1 screws that secure the rubber feet and chip tray to the machine (if already fitted.)
2. Use the diagram shown in **Figure 7** as a drill pattern to drill your holes into your workbench.

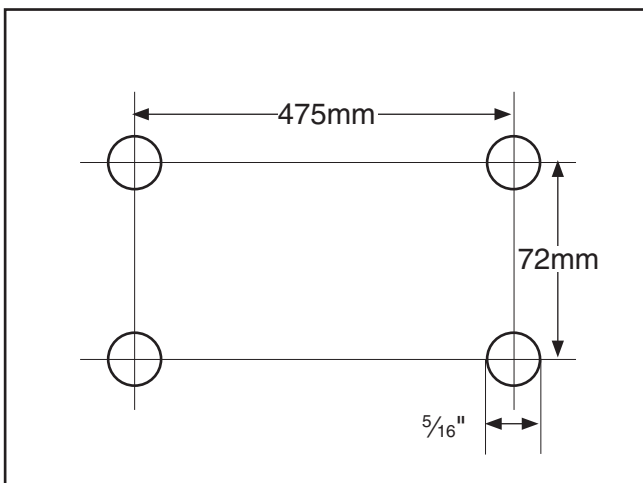

Figure 7. G8688 drill pattern.

3. Use the appropriate length M6-1 bolts with a flat washer to secure the lathe and chip tray to the workbench.

The rubber feet are attached to two metal brackets. The feet and the brackets bolt through the chip tray and into the base of the lathe.

To attach the rubber feet:

1. Remove the four Phillips head screws from the bottom of the chip tray.
2. Attach the two brackets with the screws you removed in **Step 1** (see **Figure 8**).

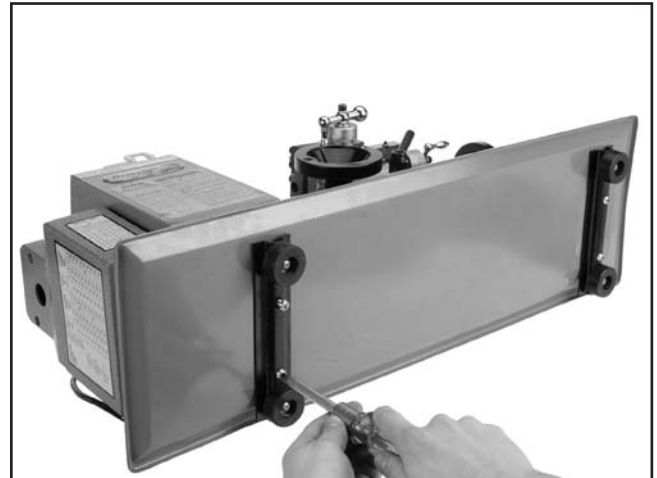

Figure 8. Installing the feet.



Installing Handwheel Handles

Components and Hardware Needed:	Qty
Handwheel Handles	2

To install the handwheel handles:

1. Using a screwdriver and 14mm open end wrench, thread the handwheel handles into the longitudinal and cross feed handwheels (see **Figure 9**).
2. Tighten the nut securely against the handwheel while ensuring the handle can spin freely around the bolt with minimal end play.

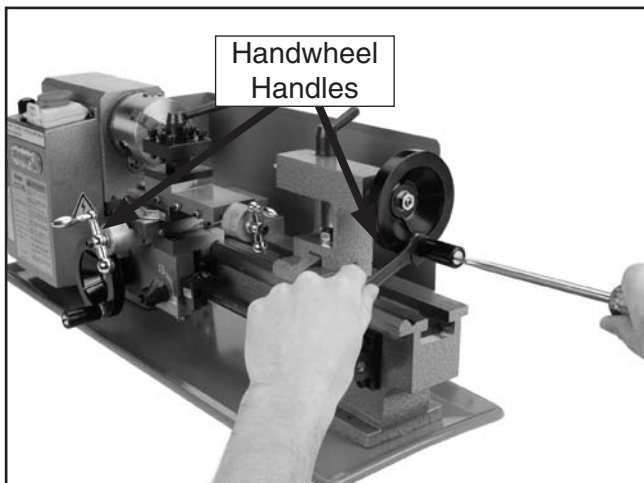

Figure 9. Installing the handwheel handles.

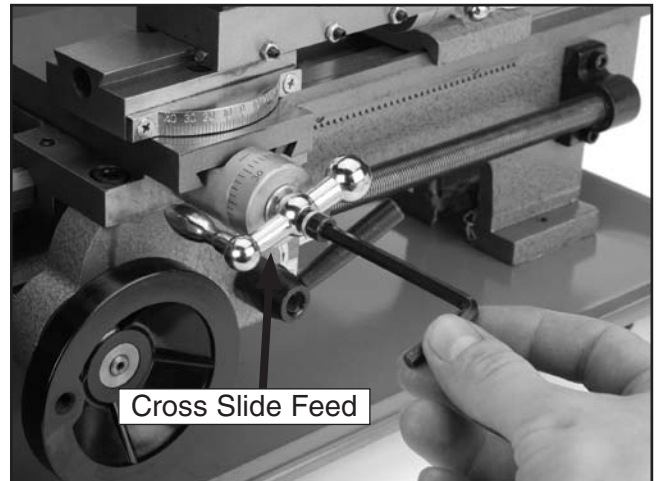
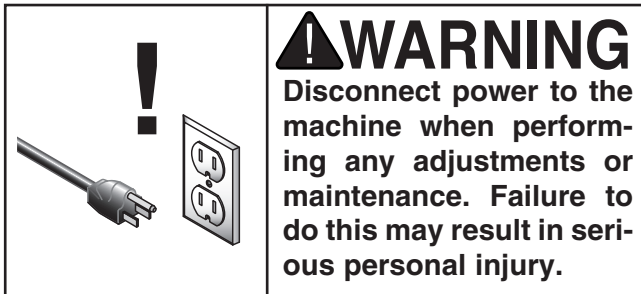
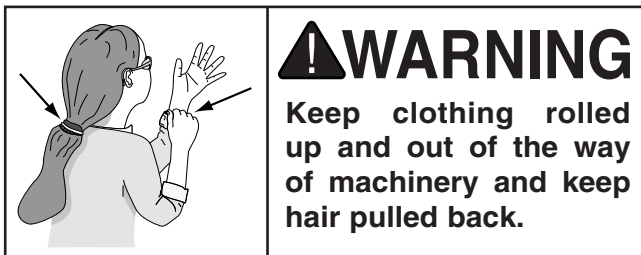

Figure 10. Flipping the handle.

3. The cross slide feed has been turned around for shipment. With a 5mm hex wrench, remove the cap screw, turn the handle around, and retighten the cap screw (see **Figure 10**).



Test Run



The purpose of the test run is to make sure the lathe is working properly.

To perform the test run:

1. Inspect the machine to ensure that all hand tools are out of the way, the chuck key is removed from chuck, and nothing is impeding the movement of the chuck. Check this by rotating the chuck by hand.
2. Set the lathe to LOW range on the back of the headstock. See **Page 18** for control locations.
3. Plug the lathe in, and set the FORWARD/OFF/REVERSE switch to FORWARD.
4. Lift the EMERGENCY STOP button in the direction of the arrow on the button and allow the button to pop out.
5. Gently rotate the VARIABLE SPEED CONTROL DIAL. A click will be heard as power is turned **ON**, speed will increase the further the knob is turned. The lathe should run smoothly with little or no vibration or rubbing noises when it starts. Strange or unnatural noises should be investigated and corrected before operating the machine further.
6. If the lathe is running smoothly, allow it to run for several minutes. Gradually increase the RPM and let it run a couple of minutes at each change until you reach the maximum RPM of 2500.
7. Turn the lathe **OFF** by pressing the EMERGENCY STOP button or turn the VARIABLE SPEED CONTROL DIAL counterclockwise and return other switches to the **OFF** position.
8. Repeat this process in the REVERSE position.



SECTION 4: OPERATIONS

!WARNING

Damage to your eyes, lungs, and ears could result from using this machine without proper protective gear. Always wear safety glasses, a respirator, and hearing protection when operating this machine.

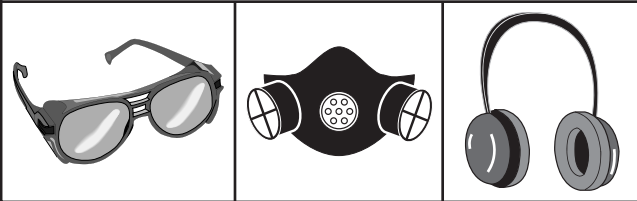

!WARNING

Loose hair and clothing could get caught in machinery and cause serious personal injury. Keep loose clothing and long hair away from moving machinery.

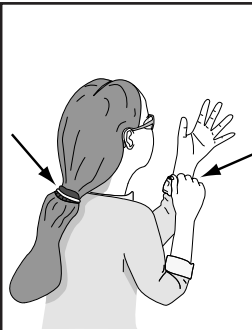

NOTICE

If you have never used this type of machine or equipment before, WE STRONGLY RECOMMEND that you read books, trade magazines, or get formal training before beginning any projects. Regardless of the content in this section, Grizzly Industrial will not be held liable for accidents caused by lack of training.

Speed & Power Controls

It is important to know all of the controls on the G8688 before operation. Use **Figures 11 & 12** as a guide.

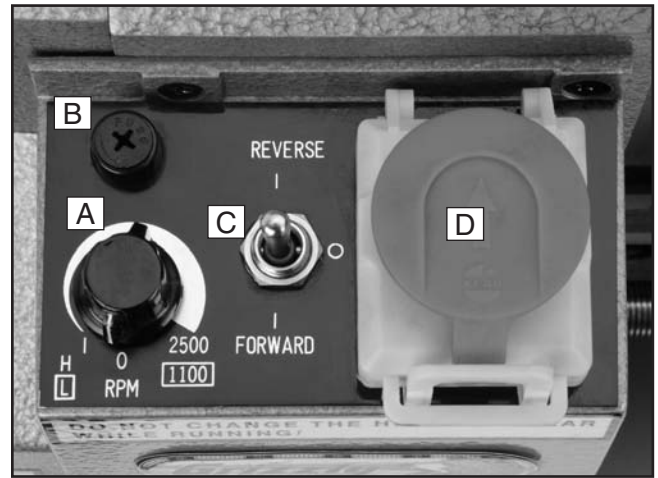

Figure 11. Power controls and features.

NOTICE

DO NOT VOID YOUR WARRANTY! DO NOT change spindle or leadscrew direction when lathe is running! Damage to your lathe will occur!

- A. VARIABLE SPEED CONTROL DIAL:** Controls the spindle speed range from 0-2500 RPMs.
- B. Fuse Socket:** Houses a 5 Amp system fuse.
- C. FORWARD/OFF/REVERSE Toggle:** Changes spindle direction from clockwise/neutral/counter-clockwise. **DO NOT** change direction while lathe is running.
- D. EMERGENCY STOP Button:** Shuts off power to the motor when closed as shown.



Chuck Jaws

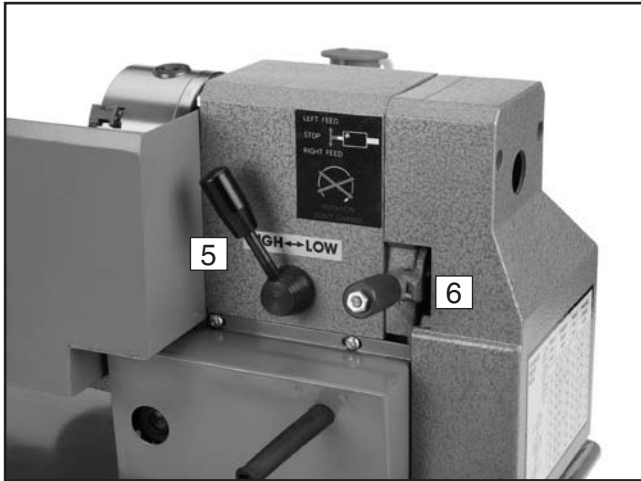

Figure 12. Rear controls.

5. **HIGH/LOW Range Control:** Shifts the spindle speed range from HIGH range, 0-2500 RPM to LOW range, 0-1100 RPM.

Note: *DO NOT shift from HIGH to LOW while the lathe is running!*

6. **LEADSCREW FORWARD/NEUTRAL/REVERSE Lever:** Changes leadscrew rotating direction for power feed or threading operations.

Note: *DO NOT shift leadscrew direction while the lathe is running!*

The 3-jaw chuck supplied with the lathe comes with 2 sets of jaws which are depicted in **Figure 13**. These are commonly known as the internal and external jaws. The internal jaw can hold a workpiece on the inside or outside surface of the jaw (exterior or interior of the part). The external jaw holds the part from the inside surface of the jaw (exterior of the part). Common uses are shown in **Figure 14**.

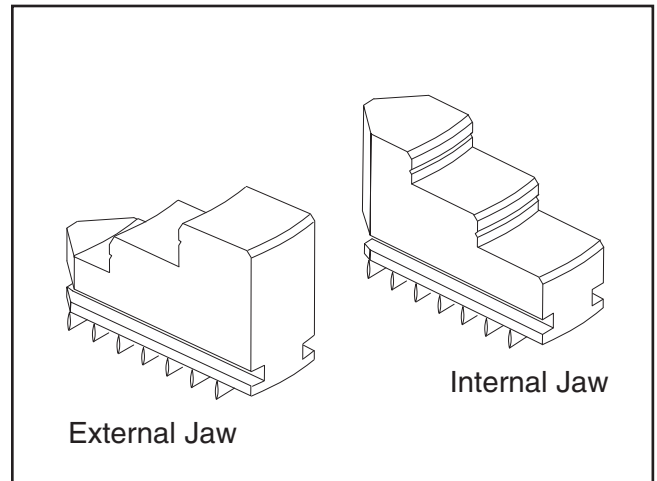

Figure 13. Internal & external jaws.

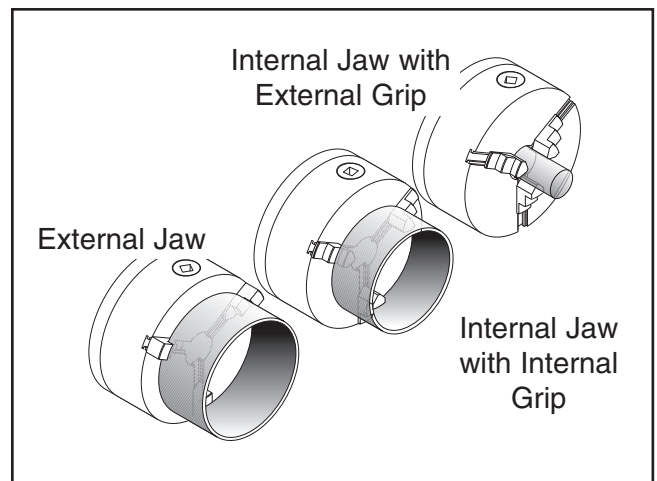

Figure 14. Workholding options.



Replacing Chuck Jaws

Changing jaws on the 3-jaw chuck is straight forward, but attention must be paid to the sequence in which the jaws are loaded into the chuck.

To replace the jaws:

1. UNPLUG THE LATHE!
2. Remove all of the jaws on the chuck by turning the chuck key counterclockwise.
3. Examine the inside of each slot in the chuck for debris and clean.
4. Each jaw will be numbered 1,2,3 or A,B,C. Numbers can be found in the slot, at the bottom of each jaw.
5. Locate jaw #1.
6. Insert the chuck key into the chuck.
7. Turn the chuck key clockwise while looking straight into the face of the chuck. Notice the beginning of the lead thread on the scroll come into view through the slot in a counterclockwise direction (see **Figure 15**).

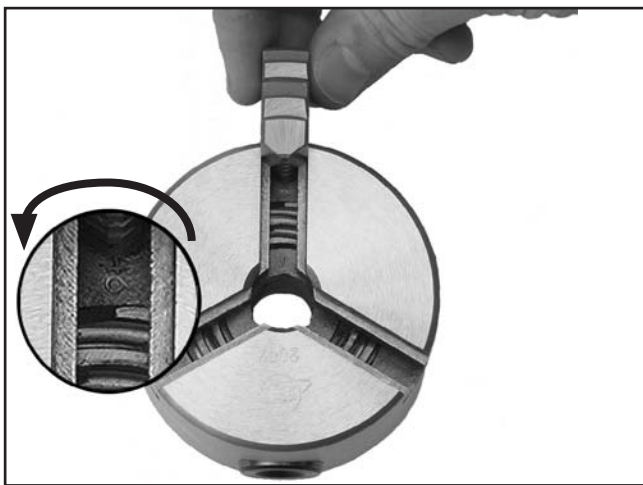

Figure 15. Lead thread.

8. Insert jaw # 1 into this slot then continue to turn until the jaw is engaged with the lead thread.
9. Repeat these steps for Jaw #2 then Jaw #3.

It is important to follow these points when replacing jaws in your 3-jaw chuck:

- The jaws must be loaded in sequence beginning with the #1 jaw.
- The chuck, scroll, and jaws should be thoroughly cleaned before assembly. (A paint brush works great for cleaning the scroll).
- Never use a combination of inside and outside jaws to hold a workpiece.
- DO NOT over-tighten the chuck jaws. Damage will occur, resulting in loss of accuracy.
- DO NOT load the jaws into chuck incorrectly to do eccentric work. Use a 4-jaw chuck for this purpose.
- 3-jaw chucks will always have a little run-out. It is advisable to measure the run-out of a workpiece after it is mounted in the chuck. If a higher degree of accuracy is desired, replace the 3-jaw chuck with a 4-jaw chuck and adjust the workpiece while using a dial indicator until the desired concentricity is achieved.



Removing/Installing Chuck or Faceplate

The Model G8688 chuck is mounted directly to the spindle nose plate by the use of studs and hex nuts.

To remove a chuck or faceplate from the lathe spindle:

1. UNPLUG THE LATHE!
2. Place a piece of plywood over the bedways to protect your hands and the precision ground bedways in case the chuck should fall.



3. Hold the chuck/faceplate with your hand or a chuck key, and use a 10mm wrench, to loosen and remove the three chuck mounting hex nuts on the back of the spindle nose plate.
4. Remove the chuck/faceplate from the spindle nose by pulling it out.

Note: You may need to tap the chuck/faceplate with a rubber mallet to brake it free of its seal.

To install the chuck or faceplate:

1. Remove the studs from the chuck or faceplate you just removed, and screw them into the chuck or faceplate you want to install.
2. Measure the stud protrusion, and make sure that the studs extend at least $\frac{1}{2}$ " from the chuck or faceplate (see **Figure 16**).

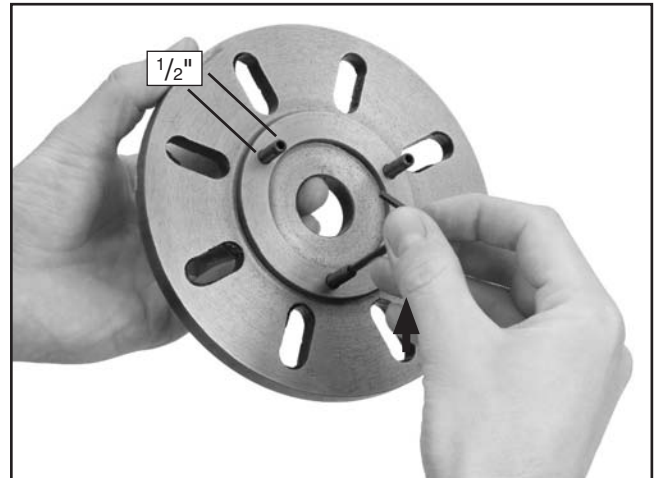

Figure 16. Installing studs.

3. Line up the studs with the holes on the spindle nose and secure the chuck/faceplate with the hex nuts (see **Figure 17**).

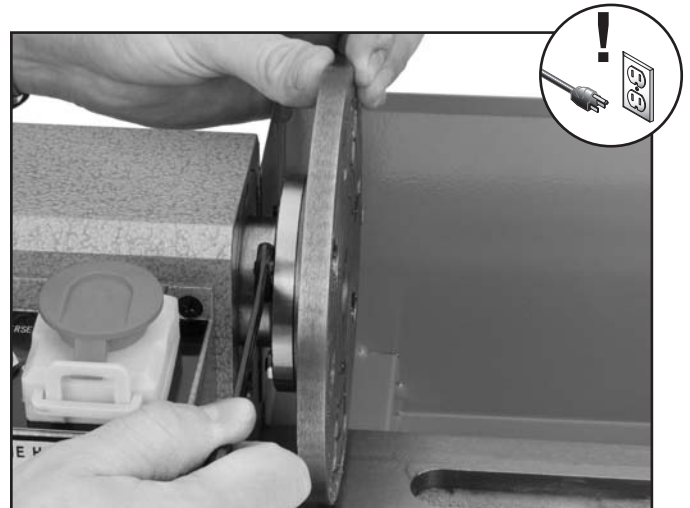

Figure 17. Installing the faceplate.



Tailstock

The tailstock may be moved along the bedway to any desired position and locked in position by a hex nut at its base. The tailstock quill is a MT#2 taper and will hold tools that match that taper, such as dead center (included), live centers, drill chucks with arbors, and drill bits with tapers.

Familiarize yourself with the tailstock components shown in **Figure 18**.

- A. Quill Lock:** Locks the quill in position.
- B. Tailstock Handwheel:** Moves the quill in and out of the tailstock.
- C. Tailstock Lock Nut:** Locks the tailstock in position to the lathe bed.
- D. Offset Setscrew:** Helps maintain tailstock position during tailstock offset adjustment.
- E. Quill:** Holds tapered tools.
- F. Offset Cap Screw:** Loosening allows tailstock offset to be adjusted right or left of center.
- G. Quill Gib Screw:** Removes play from tailstock quill.

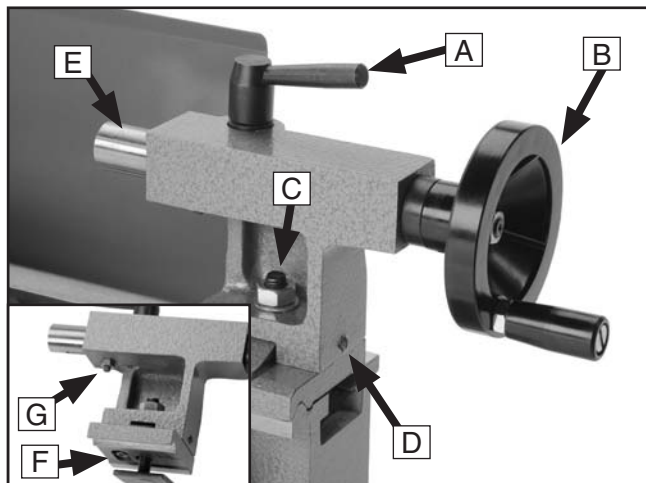

Figure 18. Tailstock controls.

Tailstock Positioning

Longitudinal Positioning

To adjust the tailstock longitudinally:

1. Using a 17mm wrench, loosen the tailstock lock nut shown in **Figure 18**.
2. Slide the tailstock into position along the bed, then tighten the clamp nut to secure the tailstock in the new position.

Offset Positioning

Changing the tailstock offset is a common method for turning tapers. The offset cap screw is located under the tailstock and the tailstock must be removed from the bed for this adjustment. Therefore, precision tolerances for this type of work will require trial-and-error adjustments (**Figure 18**).

To offset the tailstock:

1. Loosen the tailstock lock nut with a 17mm hex wrench and slide the tailstock off the lathe bed.
2. Loosen the offset cap screw just enough so the tailstock can slide.
3. Slide the tailstock back onto the bed, then adjust to the desired offset.
4. Tighten the setscrew to hold the tailstock in position.
5. Carefully slide the tailstock off of the bed, then tighten offset cap screw.
6. Slide the tailstock back onto the bed, lock it in position and recheck your setting.
7. Repeat these steps as often as needed to obtain your desired results.
8. For re-alignment refer to **Page 36**.



Dead Center

Stock protruding more than 2½ times its diameter should be supported by a dead or live center.

Oil the tip of the dead center and use a very slow RPM during use. Heat from friction will reduce the life of the center, and may damage the workpiece. If speed is important, invest in a live center.

To install the dead center:

1. Make sure the dead center and tailstock quill are clean and free of any dirt, dust, grease, or oil. Morse tapers will not interlock when dirt or excessive oil are present on the mounting surfaces.
2. Extend the quill approximately 1" by turning the tailstock handwheel.
3. Slide the dead center into the tailstock quill. The tapers will hold the center in place. During use, do not extend the quill less than 0, and no greater than 1½" on the quill scale.

To remove the tailstock dead center:

1. Use the tailstock handwheel to move the tailstock quill all the way back into the tailstock. This will push the dead center out of the quill.

Tool Post

The tool post can rotate to four 90 degree preset stops or at any angle in between and hold a maximum of four tools at a time.

To use the tool post:

1. Select a cutting tool that will produce the desired cut.
2. Secure the tool with a minimum of two cap screws with as little overhang as possible. This will help maintain rigidity and provide better results (see **Figure 19**).

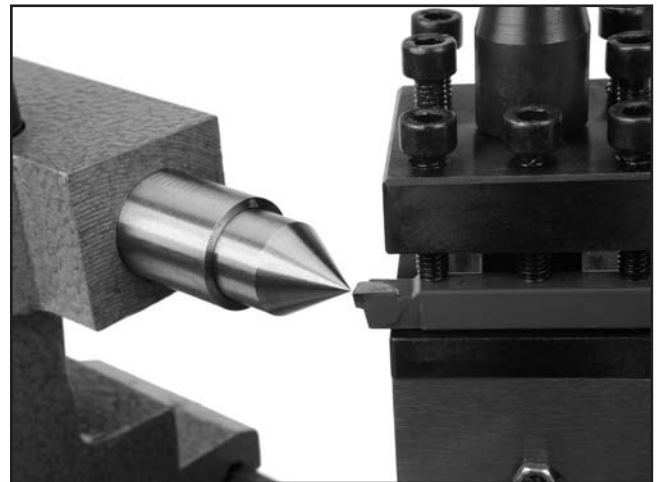

Figure 19. Proper tool post set up.

3. Make sure the tip of the tool is right at the centerline on the workpiece. If it is not, use shims under the tool to bring it up to the center line. This lathe uses 5/16" tools.

Note: To check if the tip is at the correct height, position the tool tip at the tip of the dead center in the tailstock.

—If the two tips are even or the tool tip is lower than the dead center tip, the tool is at the correct height.

—If the tool tip is above the dead center tip, it needs to be replaced with the correct tool or ground to bring it to center.



Steady Rest

The steady rest serves as a support for long round shafts (l/d ratio of 3:1 or greater). The steady rest can be placed anywhere along the length of the workpiece.

To install/use the steady rest:

1. Place the steady rest on the lathe bedways so the triangular notch fits over the angled portion of the bedway.
2. Tighten the bolt to hold the steady rest firmly in position (see **Figure 20**).

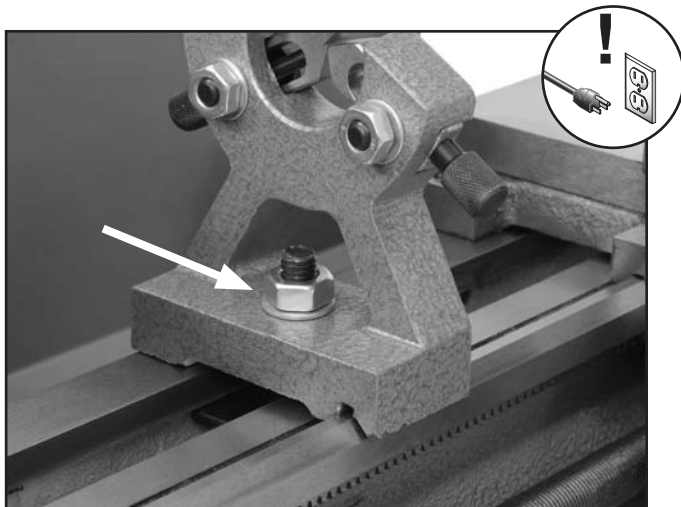

Figure 20. Installing steady rest.

3. Loosen the three hex nuts and knurled screws so the finger position can be adjusted to fit around the outer diameter of the part.
4. Place the workpiece so it can fit inside the fingers. Secure the two ends of the workpiece with the chuck and dead center or between two centers as required (see **Figure 21**).

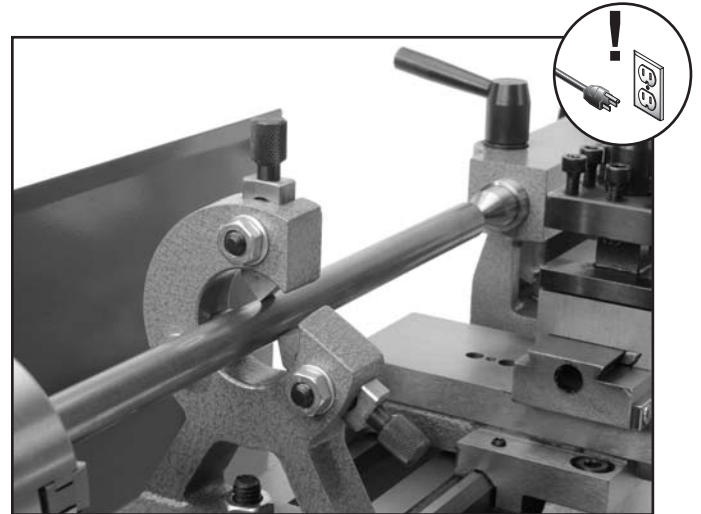

Figure 21. Steady rest.

5. Position the steady rest where desired. Tighten the bolt at base of the steady rest to secure in place.
6. Set fingers snug while allowing free rotational movement of the workpiece. Secure the fingers by tightening the three hex nuts. Lubricate the finger tips with an anti-seize grease during operation.
7. After prolonged use, the fingers will show wear. Either mill or file the tips for a new contact surface.



Cross Slide

The cross slide moves perpendicular to the longitudinal axis and features a scale on the handwheel that displays graduations of one thousandths of an inch (0.001").

To adjust the cross slide:

1. Using the handwheel, back the cross slide away from your starting point by at least 0.015", then move the cross slide forward to your starting point.

Note: This procedure will clear any free movement (or backlash) in the lead screw so your handwheel scale reading will be accurate. A small amount of free-play is normal, and must always be taken into account when using the cross slide.

2. Hold the handwheel still and turn the scale so the "0" mark lines up with the "0.000" mark on the cross slide, as shown in **Figure 22**. As long as you avoid backlash by continuing to move the cross slide in the same direction, the scale on the handwheel will be accurate.

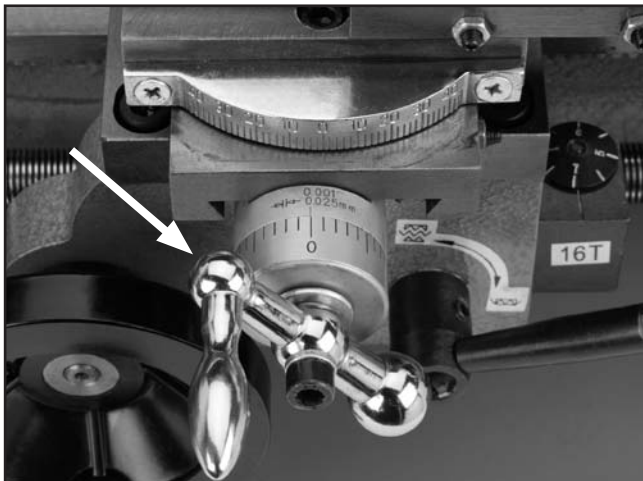

Figure 22. Cross slide handle and scale.

3. After backing the cross slide away from the workpiece, remember to clear the backlash before moving the cross slide forward to the "0" mark for the next cut.

Compound Slide

Similar to the cross slide, the compound slide features a scale that displays graduations of one thousandths of an inch (0.001"). Unlike the cross slide, the compound slide can be rotated to a set angle and then it can be moved back and forth along the axis of that angle.

To adjust the compound slide:

1. Loosen the compound slide bolts shown in **Figure 23** to allow it to be rotated.

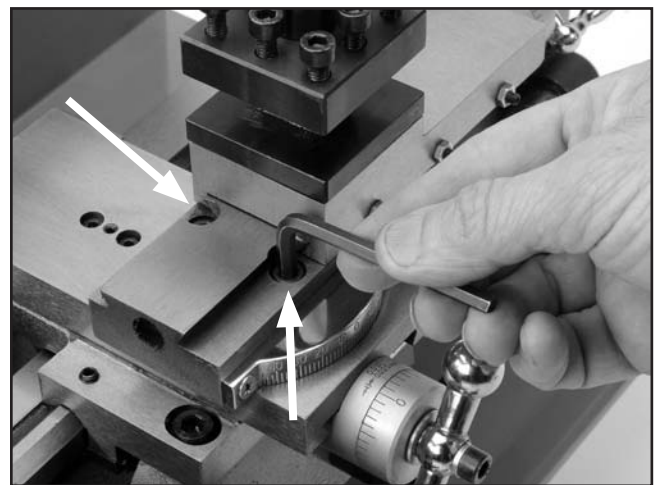

Figure 23. Compound slide bolts.

2. Rotate the compound slide to the angle needed for your procedure.
3. Tighten the compound slide bolts, and check the angle again to make sure it did not move during tightening.
4. Use the compound slide handwheel to move the tool back and forth along the axis of the new angle. Similar to adjusting the cross slide handwheel, make sure the threads are engaging and all backlash has been cleared before you set the handwheel scale to "0", or it will not be accurate.



Carriage

The longitudinal movement of the carriage (carriage feed) on the Model G8688 can be controlled both manually and automatically.

To move the carriage feed manually:

1. Rotate the handwheel clockwise to move the carriage right and rotate the handwheel counterclockwise to move the carriage left.
2. Set the handwheel scale in the same manner as described in the **Cross Slide** instructions on **Page 25**, and be sure to account for the backlash.

Automatic Carriage Feed

The feed rate is based on the rotational speed of the leadscrew which is determined by the gear configuration in the headstock. The feed rate for normal turning is much less than used for screw cutting. Therefore, it is very important to pay close attention to the gear combinations you have chosen before engaging the auto feed lever. The lathe comes from the factory set up for normal turning. Gear changes for thread cutting will be covered later.

⚠ CAUTION

CRASHING HAZARD! Pay close attention to feed rate before engaging power feed. Be alert and ready to shut OFF power feed, otherwise carriage will crash into rotating spindle, causing damage and possible injury!

To use the automatic carriage feed for normal turning:

1. Use the manual feed handwheel to position the carriage to your desired starting point and set the scale on the handwheel to "0".
2. Set the lead screw FORWARD/NEUTRAL/REVERSE lever to FORWARD.
3. Set the FORWARD/OFF/REVERSE toggle to FORWARD.
4. Turn the VARIABLE SPEED CONTROL DIAL to the desired RPM.
5. Move the feed lever down to engage the half-nut, which in turn, makes the automatic carriage feed active (see **Figure 24**).

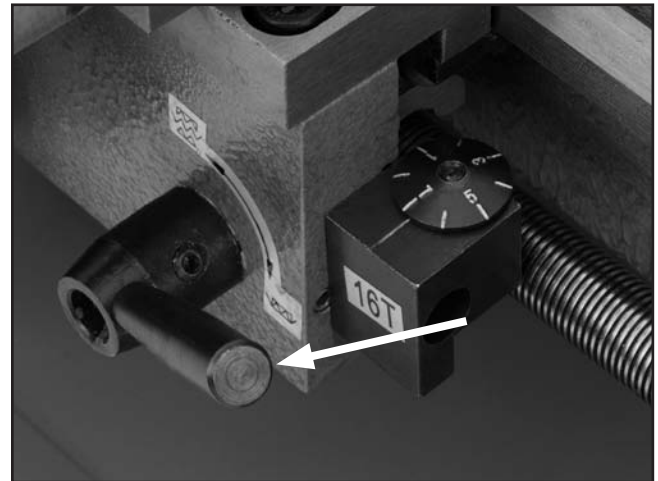

Figure 24. Feed lever.

6. Lift the feed lever to stop the automatic carriage feed.

The automatic carriage feed can also operate in the REVERSE direction by changing the leadscrew direction after turning the lathe **OFF**.



Gear Charts

The Model G8688 can be geared for a variety of different feed rates, so a chart is placed on the drive cover of the lathe that explain how to set up the gear combinations for threads per inch. The chart for metric thread pitches is included in the manual. See **Figure 27** for reference.

Threading Chart: By arranging the gears as shown on the threading charts (see **Figures 25 – 26**), you can set up the automatic carriage feed to cut any of the threads per inch (TPI) or metric thread pitches indicated.

TPI	GEARS				TPI	GEARS			
	A	B	C	D		A	B	C	D
12	40	65	/	30	26	40	60	/	65
13	40	65	60	30	28	20	65	/	35
14	40	65	/	35	32	20	65	/	40
16	40	65	/	40	36	20	65	/	45
18	40	65	/	45	38	20	50	60	57
19	40	50	60	57	40	20	65	/	50
20	40	65	/	50	44	20	65	/	55
22	40	65	/	55	48	20	65	/	60
24	40	65	/	60	52	20	60	/	65

Figure 25. Threads per inch chart (TPI).

mm/ pitch	Gear			
	A	B	C	D
0.4	20	50	40	60
0.5	20	50	/	60
0.6	40	50	30	60
0.7	40	50	35	60
0.8	40	50	40	60
1.0	20	60	/	30
1.25	50	40	/	60
1.5	40	60	/	40
1.75	35	60	/	30
2.0	40	60	/	30

Figure 26. Metric thread pitch chart.

NOTICE

There are many details to thread cutting and other lathe operations. It is not within the scope of this manual to cover detailed information regarding types of cutting tools, cutting speeds and working with different types of metal. If you do not have training in this area you **MUST** seek training from a qualified person before proceeding!

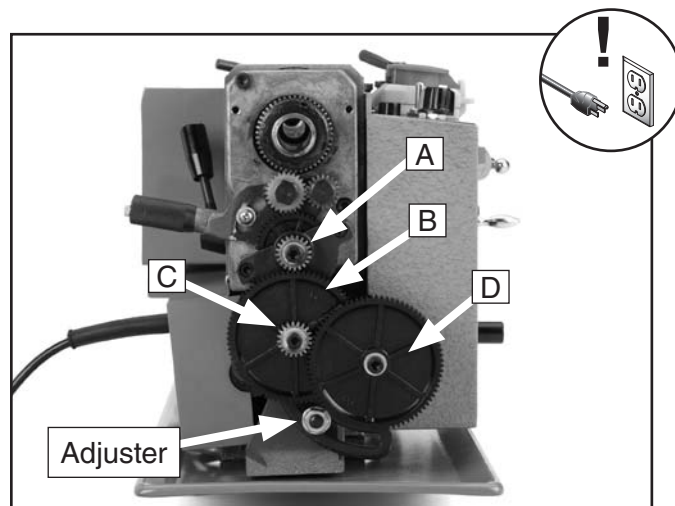

Figure 27. Gear positions.

Change Gears

Figure 27 shows the locations of the gears referenced in the gear charts **Figures 25 & 26**.

For example if you wanted to cut a 1/2" x 13 thread on a piece of round stock.

1. UNPLUG THE LATHE!
2. Remove the gear cover.
3. Loosen the adjuster to disengage the gears from each other.
4. Remove the gears in place and replace with the 40, 65, 60, & 30 tooth gears in the called out positions.
5. Position the adjuster so the gears mesh.



For example if you wanted to cut a ¼" x 20 thread on a piece of round stock.

1. UNPLUG THE LATHE!
2. Remove the gear cover.
3. Loosen the adjuster to disengage the gears from each other.
4. Remove the gears in place and replace with the 40, 65, & 55 tooth gears in the called out positions.

Note: *The C combination gear is not required.*

5. Remove the bushing from the D shaft and engage D gear directly to B gear.
6. Slip the bushing back over the shaft to hold D gear in position.
7. Position the adjuster so the gears mesh.

Cutting Threads

To cut threads:

1. Set the compound rest to the appropriate angle for the given thread you want to cut.
2. Set the tool tip perpendicular to the workpiece and center it vertically.
3. Make sure the thread dial is engaged with the lead screw.
4. Examine the thread charts and select the gear ratios you need (see **Figures 25 & 26**).
5. Turn the spindle **ON** and select the RPM you want to use. Check to see that the lead screw is turning and verify that the apron moves in the correct direction by engaging the feed lever.

6. Once you are confident the settings are correct, disengage the feed lever and turn the spindle **OFF**.
7. Examine the thread dial chart in **Figure 28** to determine which numbers (on the thread dial) to engage the feed lever.

Note: *There are a total of eight marks on the thread dial, ranging 1–8. To maintain accuracy and consistency, engage the half nut on the same mark on each pass. Failure to start on the same number each time may lead to cutting off the thread made in the previous pass.*

G8688 THREAD DIAL			
TPI	SCALE	MM/ PITCH	SCALE
12	1,3,5,7	0.4	1,3,5,7
13	1	0.5	1 – 8
14	1 or 5	0.6	1 – 8
16	1 – 8	0.7	1 or 4.5
18	1 or 5	0.8	1 or 5
19	1	1.0	1 – 8
20	1,3,5,7	1.25	1 or 3.5
22	1 or 5	1.5	1 – 8
24	1 – 8	1.75	1 or 4.5
26	1 or 5	2.0	1 – 8
28	1,3,5,7		
32	1 – 8		
36	1,3,5,7		
38	1 or 5		
40	1 – 8		
44	1,3,5,7		
48	1 – 8		
52	1,3,5,7		

Figure 28. G8688 Thread dial chart.



SECTION 5: ACCESSORIES

- T20501—Face Shield Crown Protector 4"
- T20502—Face Shield Crown Protector 7"
- T20503—Face Shield Window
- T20452—"Kirova" Anti-Reflective S. Glasses
- T20451—"Kirova" Clear Safety Glasses
- H0736—Shop Fox® Safety Glasses
- H7194—Bifocal Safety Glasses 1.5
- H7195—Bifocal Safety Glasses 2.0
- H7196—Bifocal Safety Glasses 2.5



Figure 29. Eye protection assortment.

- G3632—Dial Indicator 0-1/2"
- G1479—Dial Indicator 0-1"

Precision Dial Indicators are designed for use with magnetic bases. Great for measuring run out on lathes, blades, etc. to 0.001 resolution.



Figure 30. Dial Indicator.

- G9256—6" Dial Caliper
- G9257—8" Dial Caliper
- G9258—12" Dial Caliper

These traditional dial calipers are accurate to 0.001" and can measure outside surfaces, inside surfaces, and heights/depths. Features stainless steel, shock resistant construction and a dust proof display.

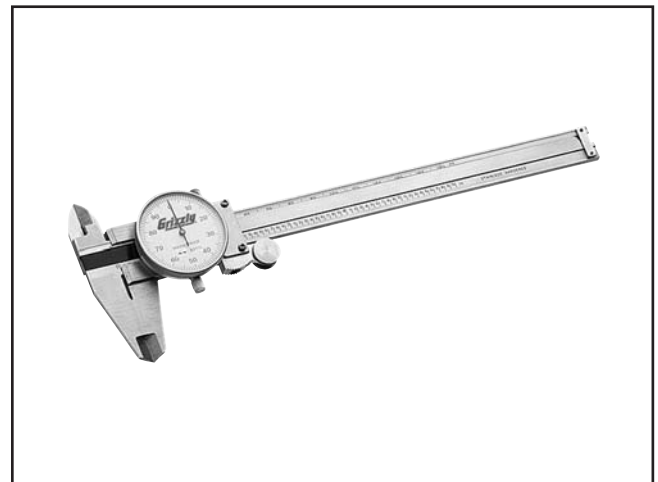

Figure 31. Grizzly® Dial Calipers.

- G5685—MT #1 Live Center
- G5686—MT #2 Live Center
- G5687—MT #3 Live Center

Perfect for just about any turning requirement, these dust, chip, and oil proof live centers feature 60° included angle and pre-loaded taper bearings.



Figure 32. Live center.

Call 1-800-523-4777 To Order



MODEL	SIZE	BODY DIA.	DRILL DIA.	OVERALL LENGTH
H4456	1	1/8"	3/64"	1 1/4"
H4457	2	3/16"	5/64"	1 7/8"
H4458	3	1/4"	7/64"	2"
H4459	4	5/16"	1/8"	2 1/8"
H4460	5	7/16"	3/16"	2 3/4"
H4461	6	1/2"	7/32"	3"
H4462	7	5/8"	1/4"	3 1/4"
H4463	8	3/4"	5/16"	3 1/2"

These High Speed Steel Center Drills are precision ground for unsurpassed accuracy.

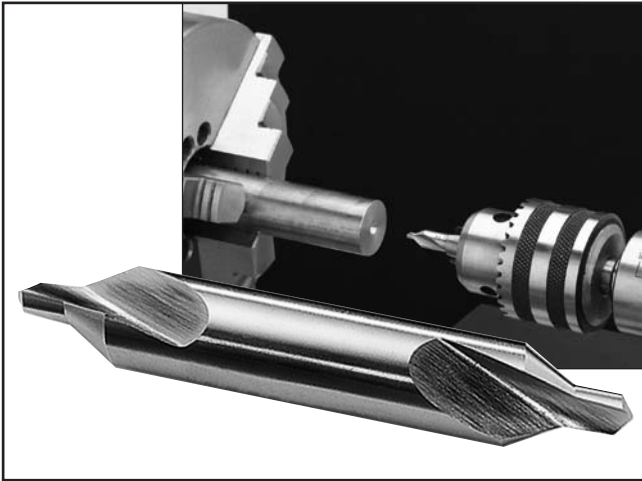

Figure 33. H4456-63 HSS Ground Center Drills.

G9864—3" Four-Jaw, Plain Back Independent Chuck

Four-Jaw Chucks are used for holding odd shaped pieces or where zero tolerance is required. These four-jaw chucks have semi-steel bodies and hardened reversible jaws.



Figure 34. Model G9864 4-Jaw Chuck.

H1508—HSS Square Tool Bits 5/16" x 5/16" x 2 1/2"
Our ground tool bits are M-2 HSS, making them some of the most durable tool bits around. Make your own specialized cutters in any shape using a silicon carbide grinding wheel (G8235-37) on your grinder.

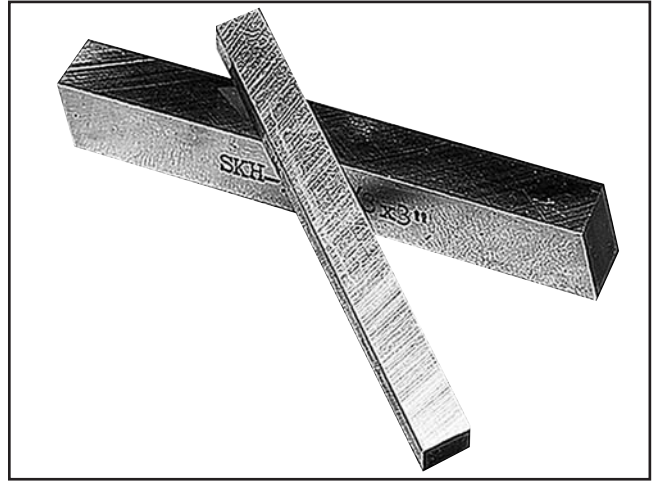

Figure 35. H1508 HSS Square Tool Bits.

H5690—8-Pc. Pre-Ground Tool Bit Set

Tired of grinding your blank high speed steel tool bits? We've done it for you! 8-pc set comes with these sharpened profiles: offset right and left hand tools with chip breaker, straight and chip breaker style threading tools, internal threading tool, parting tool, boring tool and turning tool. These tool bits are evenly hardened to better than 64C.

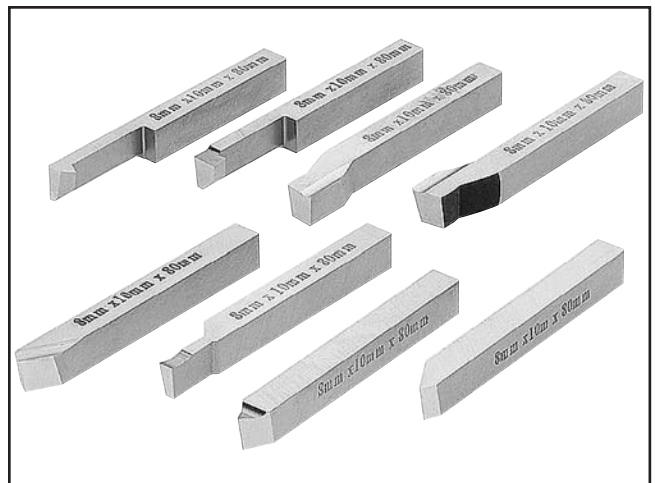
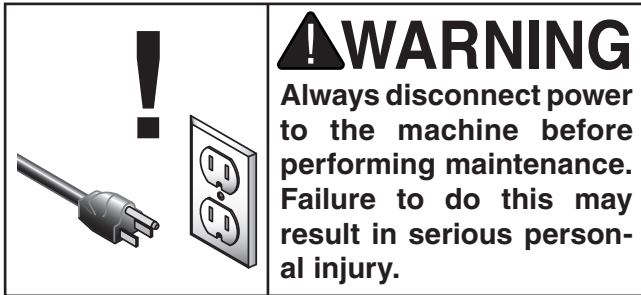

Figure 36. H5690 Pre-Ground Tool Bit Set.

Call 1-800-523-4777 To Order



SECTION 6: MAINTENANCE



Schedule

For optimum performance from your machine, follow this maintenance schedule and refer to any specific instructions given in this section. Your use and certain shop environments may require you to perform these tasks more often.

Daily:

- Loose mounting bolts.
- Damaged parts.
- Poorly adjusted parts.
- Worn or damaged wires.
- Any other unsafe condition.
- Dirty machine.
- Clean tooling and storage.

Monthly:

- Gear damage, wear, rust, sludge, or chip build-up inside gearbox and off motor. Clean and lube as necessary.

Cleaning

Cleaning the Model G8688 is relatively easy. Remove all chips at the end of the day. Wipe up any coolant used that settled in the bottom of the chip tray or has settled on any other part of the lathe. Dry off entire machine with a clean, dry towel. DO NOT use compressed air to clean your lathe.

Lubrication

- **Daily:** Clean all machined surfaces, including chuck, and apply a thin film of ISO 68 gear oil or 10-30W synthetic motor oil.
- **Daily:** Put a few drops of ISO 68 gear oil or 10-30W synthetic motor oil on the bearing on each end of the leadscrew. You will need to remove the gear cover to access the left hand bearing.
- **Daily:** Clean and add a couple extra drops of ISO 68 gear oil, 10-30W synthetic motor oil, or way oil to the sliding surfaces of the bedway, cross slide and compound slide.
- **Every Six Months:** Apply a thin film of white lithium grease to the cross slide and compound slide leadscrews.
- **Every Six Months (or As Necessary):** Apply a thin film of white lithium grease to headstock and carriage drive gears.
- **Yearly:** Apply a thin film of white lithium grease tailstock quill and screw.
- **Yearly:** Use a spray lithium grease to lubricate the transmission gears. To do this, disconnect power, remove the front control panel, remove ground wire screw in headstock, spray grease in hole while rotating chuck by hand and shifting gears between High and Low.



SECTION 7: SERVICE

Review the troubleshooting and procedures in this section to fix your machine if a problem develops. If you need replacement parts or you are unsure of your repair skills, then feel free to call our Technical Support at (570) 546-9663.

Troubleshooting

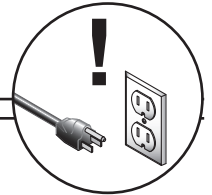

Motor & Electrical

Symptom	Possible Cause	Possible Solution
Machine does not start or a breaker trips.	<ol style="list-style-type: none"> 1. Fuse has blown. 2. Emergency stop push-button is engaged/faulty. 3. Plug/receptacle is at fault or wired incorrectly. 4. Computer board is at fault. 5. Power supply is at fault/switched OFF. 6. Motor ON button or ON/OFF switch is at fault. 7. Spindle rotation switch is at fault. 8. Wiring is open/has high resistance. 9. Motor is at fault. 	<ol style="list-style-type: none"> 1. Correct short/replace fuse on control panel. 2. Rotate clockwise slightly until it pops out/replace it. 3. Test for good contacts; correct the wiring. 4. Inspect computer board; replace if faulty. 5. Ensure hot lines have correct voltage on all legs and main power supply is switched ON. 6. Replace faulty ON button or ON/OFF switch. 7. Turn switch to FWD/REV; replace bad switch. 8. Check for broken wires or disconnected/corroded connections, and repair/replace as necessary. 9. Test/repair/replace.
Machine stalls or is underpowered.	<ol style="list-style-type: none"> 1. Wrong workpiece material (metal). 2. Computer board is at fault. 3. Motor speed rheostat is at fault. 4. Motor brushes are at fault. 5. Pulley/sprocket slipping on shaft. 6. Motor bearings are at fault. 7. Machine is undersized for the task. 8. Spindle rotation switch at fault. 	<ol style="list-style-type: none"> 1. Use metal with correct properties for your type of machining. 2. Inspect and replace if faulty. 3. Test and replace if faulty. 4. Remove brushes and clean/replace (refer to Page 35). 5. Replace loose pulley/shaft. 6. Test by rotating shaft; rotational grinding/loose shaft requires bearing replacement. 7. Use sharp lathe bits/chisels at correct angle; reduce feed rate/depth of cut; use cutting fluid if possible. 8. Turn switch to FWD/OFF/REV; replace bad switch.
Loud, repetitious noise coming from machine at or near the motor.	<ol style="list-style-type: none"> 1. Pulley setscrews or keys are missing or loose. 2. Motor fan is hitting the cover. 	<ol style="list-style-type: none"> 1. Inspect keys and setscrews. Replace or tighten if necessary. 2. Tighten fan or shim cover, or replace items.
Motor overheats.	<ol style="list-style-type: none"> 1. Motor overloaded. 2. Air circulation through the motor restricted. 	<ol style="list-style-type: none"> 1. Reduce load on motor. 2. Clean out motor to provide normal air circulation.
Motor is loud when cutting. Overheats or bogs down in the cut.	<ol style="list-style-type: none"> 1. Excessive depth of cut or feed rate. 2. RPM or feed rate wrong for cutting operation. 3. Cutting tool is dull. 4. Gear setup is too tight, causing them to bind. 	<ol style="list-style-type: none"> 1. Decrease depth of cut or feed rate. 2. Refer to RPM feed rate chart for appropriate rates. 3. Sharpen or replace the cutting tool. 4. Readjust the gear setup with a small amount of backlash so the gears move freely and smoothly when the chuck is rotated by hand



Operation and Work Results

SYMPTOM	POSSIBLE CAUSE	CORRECTIVE ACTION
Entire machine vibrates excessively upon startup and while running.	<ol style="list-style-type: none"> 1. Workpiece is unbalanced. 2. Loose or damaged belt(s). 3. V-belt pulleys are not properly aligned. 4. Worn or broken gear present. 5. Chuck or faceplate has become unbalanced. 6. Spindle bearings badly worn. 	<ol style="list-style-type: none"> 1. Reinstall workpiece so it is as centered with the spindle bore as possible. 2. Tighten/replace the belt as necessary. 3. Align the V-belt pulleys. 4. Inspect gears and replace if necessary. 5. Rebalance chuck or faceplate; contact a local machine shop for help. 6. Replace spindle bearings.
Bad surface finish.	<ol style="list-style-type: none"> 1. Wrong RPM or feed rate. 2. Dull tooling or poor tool selection. 3. Too much play in gibs. 4. Tool too high. 	<ol style="list-style-type: none"> 1. Adjust for appropriate RPM and feed rate. 2. Sharpen tooling or select a better tool for the intended operation. 3. Tighten gibs. 4. Lower the tool position.
Can't remove tapered tool from tailstock quill.	<ol style="list-style-type: none"> 1. Quill had not retracted all the way back into the tailstock. 2. Debris was not removed from taper before inserting into quill. 	<ol style="list-style-type: none"> 1. Turn the quill handwheel until it forces taper out of quill. 2. Always make sure that taper surfaces are clean.
Cross slide, compound slide, or carriage feed has sloppy operation.	<ol style="list-style-type: none"> 1. Gibs are out of adjustment. 2. Handwheel is loose. 3. Lead screw mechanism worn or out of adjustment. 	<ol style="list-style-type: none"> 1. Adjust gib screw(s) (see Page 35). 2. Tighten handwheel fasteners. 3. Tighten any loose fasteners on lead screw mechanism.
Cross slide, compound slide, or carriage feed handwheel is hard to move.	<ol style="list-style-type: none"> 1. Gibs are loaded up with shavings, dust, or grime. 2. Gib screws are too tight. 3. Backlash setting too tight (cross slide only). 4. Bedways are dry. 	<ol style="list-style-type: none"> 1. Remove gibs, clean ways/dovetails, lubricate, and readjust gibs. 2. Loosen gib screw(s) slightly, and lubricate bedways. 3. Slightly loosen backlash setting by loosening the locking screw and adjusting the spanner ring at the end of the handle. 4. Lubricate bedways and handles.
Cutting tool or machine components vibrate excessively during cutting.	<ol style="list-style-type: none"> 1. Tool holder not tight enough. 2. Cutting tool sticks too far out of tool holder; lack of support. 3. Gibs are out of adjustment. 4. Dull cutting tool. 5. Incorrect spindle speed or feed rate. 	<ol style="list-style-type: none"> 1. Check for debris, clean, and retighten. 2. Reinstall cutting tool so no more than 1/3 of the total length is sticking out of tool holder. 3. Tighten gib screws (see Page 35) at affected component. 4. Replace or sharpen cutting tool. 5. Use the recommended spindle speed.
Inaccurate turning results from one end of the workpiece to the other.	<ol style="list-style-type: none"> 1. Headstock and tailstock are not properly aligned with each other. 	<ol style="list-style-type: none"> 1. Realign the tailstock to the headstock spindle bore center line (see Page 36).
Chuck jaws won't move or don't move easily.	<ol style="list-style-type: none"> 1. Chips lodged in the jaws. 	<ol style="list-style-type: none"> 1. Remove jaws, clean and lubricate chuck threads, and replace jaws.
Carriage won't feed.	<ol style="list-style-type: none"> 1. Gears are not all engaged. 2. Gears are broken. 3. Loose screw on the feed handle. 	<ol style="list-style-type: none"> 1. Adjust gear positions. 2. Replace. 3. Tighten.



SYMPTOM	POSSIBLE CAUSE	CORRECTIVE ACTION
Carriage hard to move.	<ol style="list-style-type: none"> 1. Carriage lock is tightened down. 2. Chips have loaded up on bedways. 3. Bedways are dry and in need of lubrication. 4. Longitudinal stops are interfering. 5. Gibs are too tight. 	<ol style="list-style-type: none"> 1. Check to make sure table locks are fully released. 2. Frequently clean away chips that load up during turning operations. 3. Lubricate bedways and handles. 4. Check to make sure that stops are floating and not hitting the center stop. 5. Loosen gib screw(s) slightly.
Gear change levers will not shift into position.	<ol style="list-style-type: none"> 1. Gears not aligned in headstock. 	<ol style="list-style-type: none"> 1. Rotate spindle by hand until gear falls into place.
Loud, repetitious noise coming from machine.	<ol style="list-style-type: none"> 1. Gears not aligned in headstock or no backlash. 2. Broken gear or bad bearing. 3. Workpiece is hitting stationary object. 	<ol style="list-style-type: none"> 1. Adjust gears and establish backlash. 2. Replace broken gear or bearing. 3. Stop lathe immediately and correct interference problem.
Tailstock quill will not feed out of tailstock.	<ol style="list-style-type: none"> 1. Quill lock knob is tightened down. 	<ol style="list-style-type: none"> 1. Turn knob counterclockwise.



Adjusting Gibs

NOTICE

When adjusting gibs, keep in mind that the goal of gib adjustment is to remove unnecessary movement from the slides without causing them to bind. Loose gibs may cause poor finishes on the workpiece and undue wear on the slide, nut and lead screw. Over tightening will make turning the handwheel difficult.

There are two gib adjustments for the Model G8688—the cross-slide gib and the compound slide gib. The apron gib has been adjusted at the factory and should need no further attention. See **Figure 37** for location.

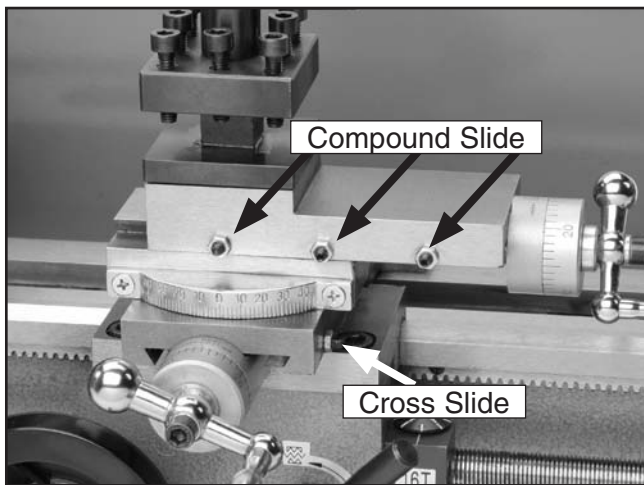

Figure 37. Gib adjustment screws.

Tools Needed	Qty
Hex Wrench 2mm.....	1
Wrench 7mm	1

To perform this procedure for the cross-slide gib and the compound-slide gib:

1. UNPLUG THE MACHINE!
2. Loosen the three locknuts.

3. Tighten or loosen the set screw and check the sliding movement. It should be even and smooth while removing any play. Readjust as needed.
4. Tighten the three locknuts.

Replacing Motor Brushes

Tools Needed	Qty
Slotted Screwdriver	1

To replace the motor brushes:

1. UNPLUG THE MACHINE!
2. Remove the front and rear caps (see **Figures 38 & 44**).

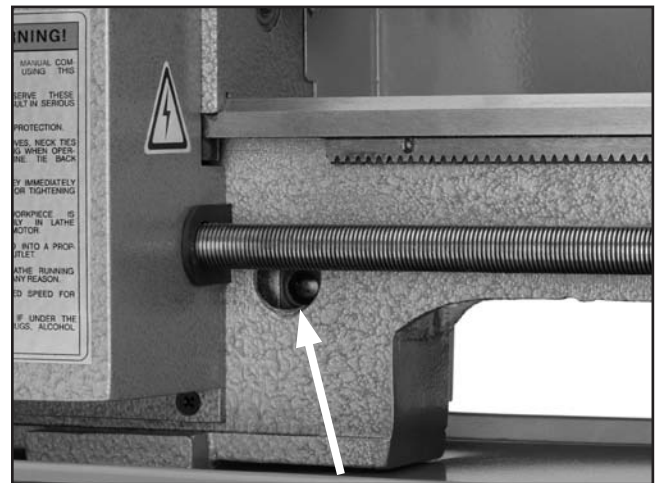

Figure 38. Front motor brush cap.

3. Replace the motor brushes.
4. Replace the caps.



Tailstock Alignment

The tailstock on the Model G8688 is aligned with the headstock at the factory. It will need to be re-aligned after adjusting for offset. See **Page 22** for instructions.

To align the tailstock:

1. Center drill a 6" long piece of round cold rolled stock on both ends. Set it aside for use in **Step 4**.
2. Make a dead center by turning a 60° point on a piece of scrap material (**Figure 39**).

Note: *As long as it remains in the chuck, the point of your new center will be accurate to your spindle axis. Keep in mind the point will have to be refinished whenever it is removed and returned to the chuck.*

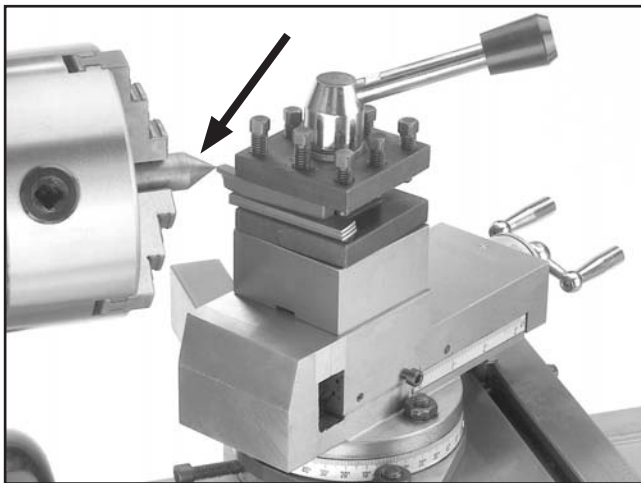

Figure 39. Finished dead center.

3. Place the dead center in your tailstock.
4. Attach a lathe dog to the bar stock and mount it between the centers (**Figure 40**).
5. Turn approximately 0.010" off of the diameter.

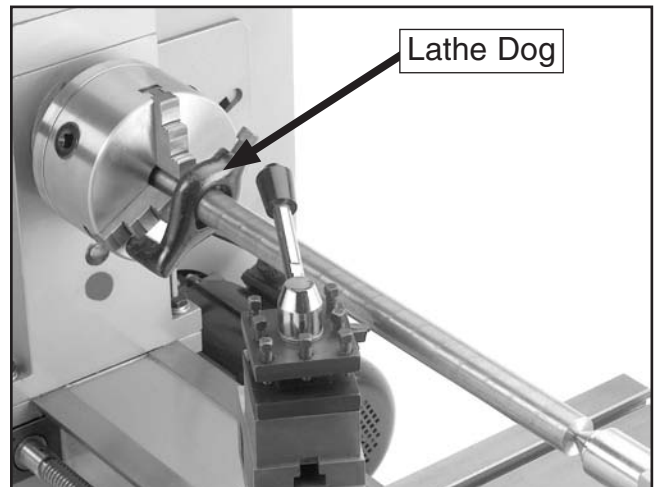

Figure 40. Bar stock mounted between centers with lathe dog.



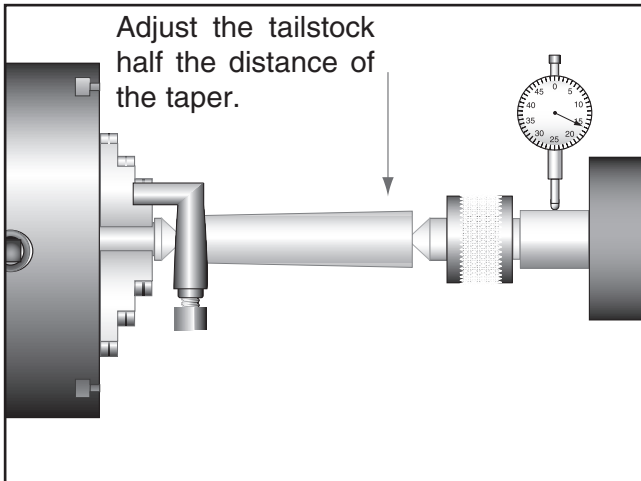

Figure 41. Adjusting for headstock end taper.

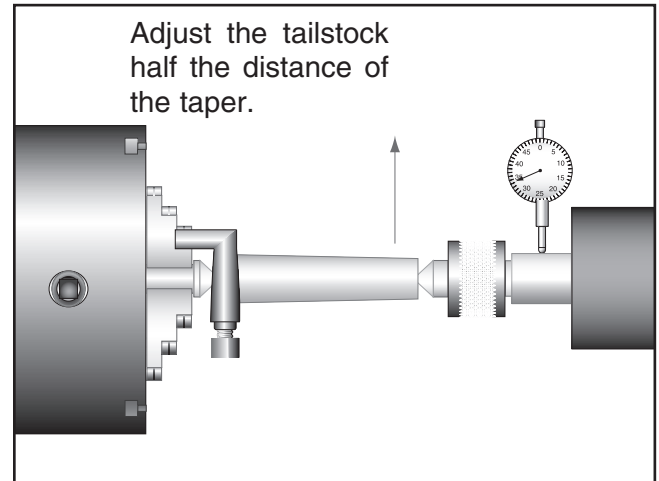

Figure 42. Adjusting for tailstock end taper.

6. Measure the workpiece with a micrometer. If the stock is fat at the tailstock end, the tailstock needs to be moved toward the operator half the amount of the taper (**Figure 41**). If the stock is thinner at the tailstock end, the tailstock needs to be moved away from the operator by at least half the amount of the taper (**Figure 42**).

7. Adjust the tailstock offset by half the amount of the taper. Turn another 0.010" off of the stock and check for a taper. Repeat as necessary until the desired amount of accuracy is achieved.

NOTICE

DO NOT forget to lock down the tailstock after each adjustment. Failure to follow this notice may cause damage to the tailstock, workpiece or both.



Electrical Components

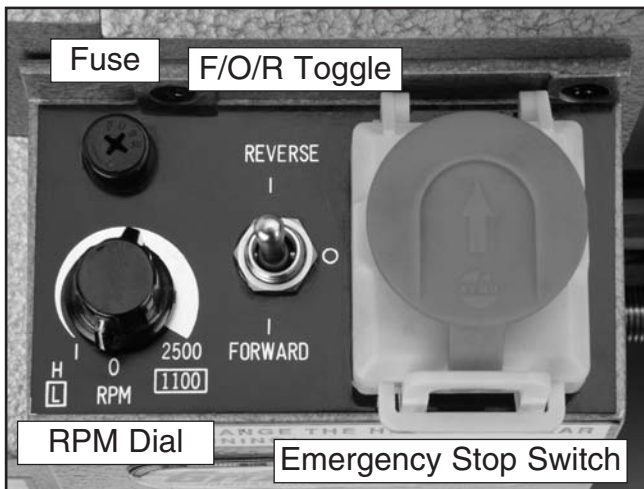

Figure 43. G8688 Fuse location.

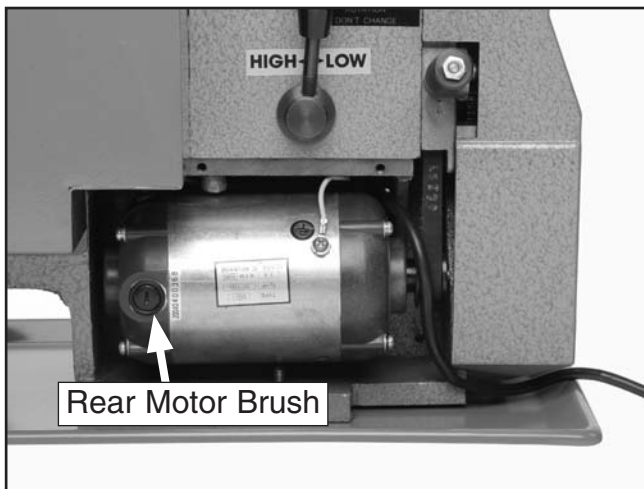

Figure 44. G8688 Motor location.

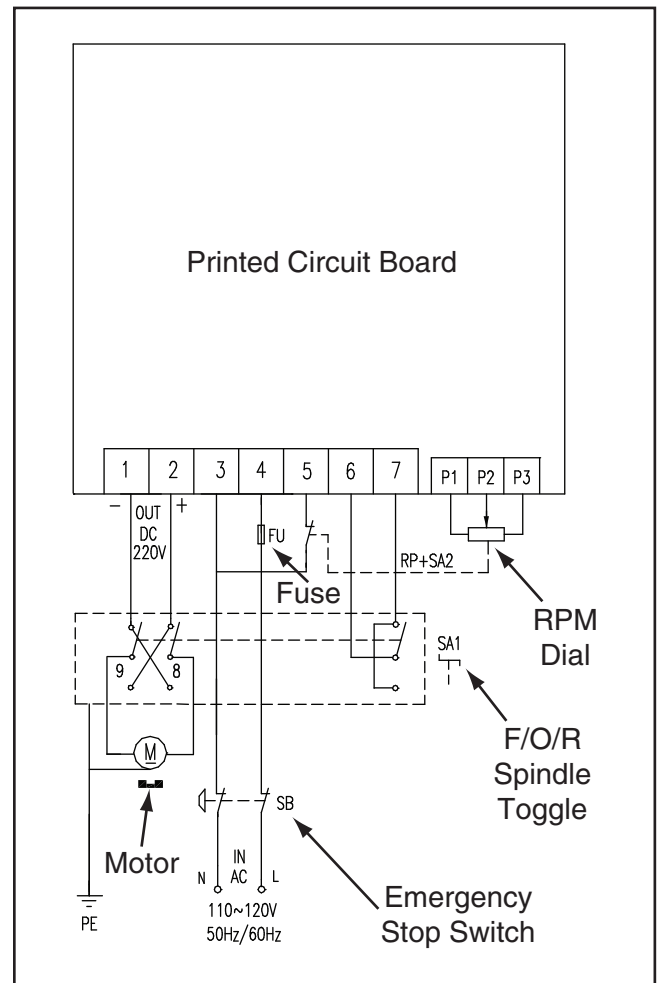
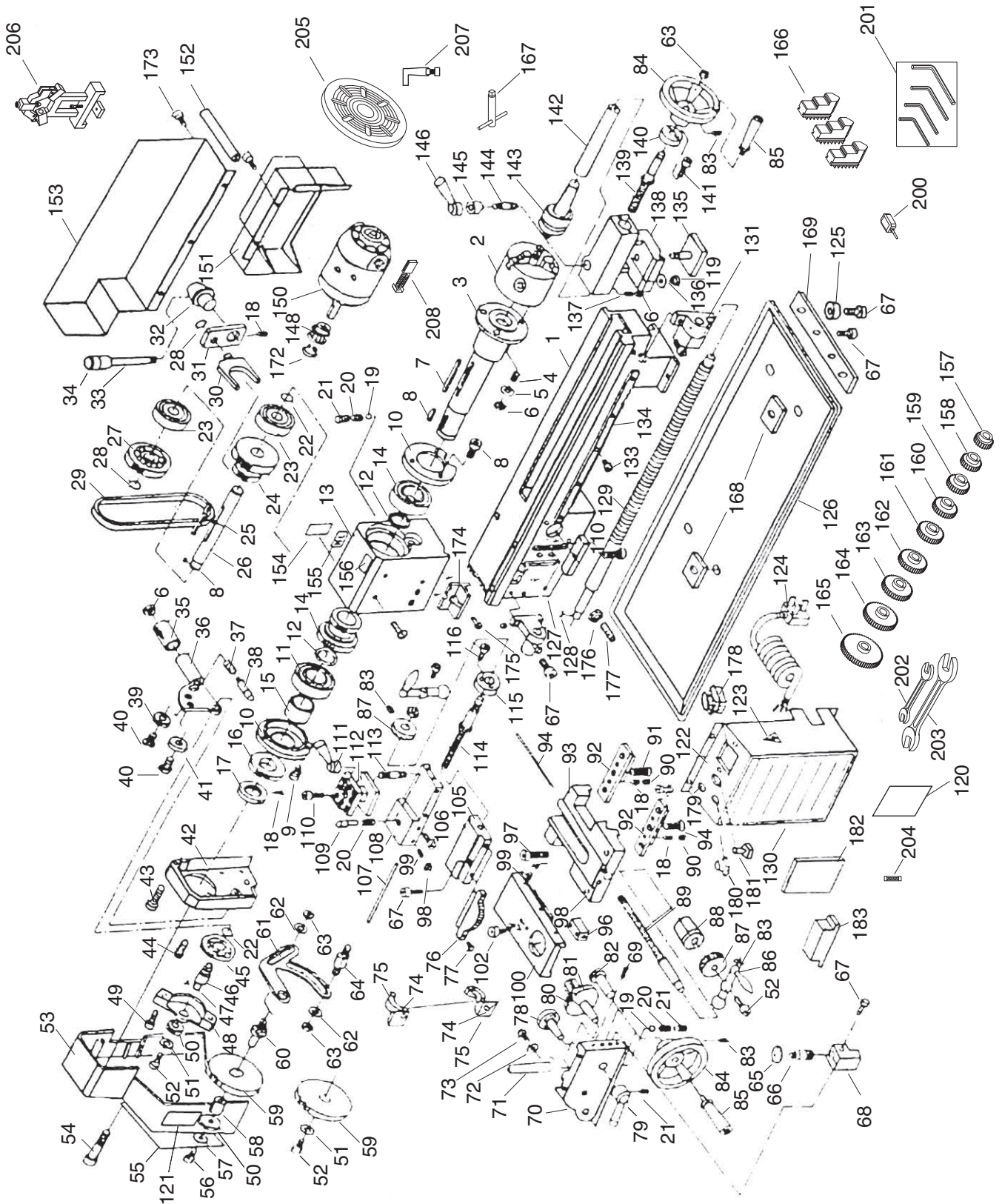

Figure 45. G8688 Wiring Diagram.



Parts Breakdown



Parts List

REF	PART #	DESCRIPTION
1	P8688001	BED WAY
2	P8688002	3 JAW CHUCK
3	P8688003	SPINDLE
4	PSS12M	SET SCREW M6-1 x 25
6	PN01M	HEX NUT M6-1
7	PK02M	KEY 5 X 5 X 40
8	PK29M	KEY 4 X 4 X 8
9	PSB33M	CAP SCREW M5-.8 X 12
10	P8688010	COVER
11	P6206ZZ	BALL BEARING 6206ZZ
12	P8688012	SPACER
13	P8688013	HEADSTOCK CASTING
14	P8689080	TRANSMISSION GEAR
15	P8688015	SPACER
16	P8688016	SPUR GEAR 45T
17	P8688017	NUT M27 X 1.5
18	PSS31M	SET SCREW M5-.8 X 8
19	P0516604	STEEL BALL 5MM
20	P8688020	COMPRESSION SPRING 4.9 X 9
21	PSS02M	SET SCREW M6-1 X 6
22	PR03M	EXT RETAINING RING 12MM
23	P8688023	BALL BEARING
24	P8688024	H/L GEAR 12T/20T
25	PK71M	KEY 4 X 4 X 45
26	P8688026	H/L GEAR SHAFT
27	P8688027	PULLEY
28	PR01M	EXT RETAINING RING 10MM
29	P8688029	TIMING BELT LX136
30	P8689141	BAR
31	P8688031	SHIFTING ARM
32	P8688032	SHIFTING KNOB
33	P8688033	SHIFTING LEVER
34	P8688034	SHIFTING GRIP
35	P8688035	HANDLE
36	P8688036	HANDLE MOUNT
37	P8688037	COMPRESSION SPRING
38	P8688038	INDICATOR
39	P8688039	PINION 25T
40	P8688040	SUPPORT SCREW
41	P8688041	PINION 20T
42	P8688042	FIXED COVER
43	PSB02M	CAP SCREW M6-1 X 20
44	PSB03M	CAP SCREW M5-.8 X 8
45	P8688045	GEAR 45T
46	P8688046	SHAFT
47	PK03M	KEY 3 X 3 X 8
48	P8688048	MOUNT
49	PSB53M	CAP SCREW M5-.8 X 18
50	P8688050	PINION 20T
51	PW03M	FLAT WASHER 6MM

REF	PART #	DESCRIPTION
52	PSB68M	CAP SCREW M6-1 X 8
53	P8688053	COVER
54	PSB108M	CAP SCREW M5-.8 X 45
55	P8688055	THREADS CUTTING CHART
56	PSB03M	CAP SCREW M5-.8 X 8
57	PW05M	FLAT WASHER 4MM
58	P8688058	BUSHING W/KEY (2PC)
59	P8688059	GEAR 80T
60	P8688060	SHAFT
61	P8688061	SUPPORT PLATE
62	PW01M	FLAT WASHER 8MM
63	PN03M	HEX NUT M8-1.25
64	P8688064	SHAFT
65	P8688065	DIAL
66	P8688066	SHAFT 16T
67	PSB24M	CAP SCREW M5-.8 X 16
68	P8688068	DIAL INDICATOR BODY
69	PSS23M	SET SCREW M4-.7 X 10
70	P8688070	APRON
71	P8688071	GIB STRIP
72	PW05M	FLAT WASHER 4MM
73	PSB18M	CAP SCREW M4-.7 X 8
74	P8688074	SHAFT
75	P8688075	HALF NUT BASE
76	P8688076	ANGLE BLOCK
77	PFH19M	FLAT HD SCR M4-.7 X 10
78	P8688078	GROOVE CAM
79	P8688079	HANDLE
80	P8688080	SHAFT
81	P8688081	FEEDING GEAR (A) 11T/54T
82	P8688082	FEEDING GEAR (B) 24T
83	PSS01M	SET SCREW M6-1 X 10
84	P8688084	WHEEL
85	P8688085	HANDWHEEL HANDLE
86	P8688086	HANDLE, LARGE
87	P8688087	DIAL
88	P8688088	BRACKET
89	P8688089	FEED SCREW
90	PN06M	HEX NUT M5-.8
91	PSB26M	CAP SCREW M6-1 X 12
92	P8688092	SLIDE PLATE
93	P8688093	SADDLE
94	P8688094	GIB STRIP
95	P8688095	FEEDING NUT
96	P8688096	SWIVEL DISK
97	PSB14M	CAP SCREW M8-1.25 X 20
98	PN04M	HEX NUT M4-.7
99	PSS35M	SET SCREW M4-.7 X 16
100	P8688100	CROSS SLIDE



Parts List

REF	PART #	DESCRIPTION
102	PSB50M	CAP SCREW M5-.8 X 10
105	P8688105	COMPOUND REST
106	PSS35M	SET SCREW M4-.7 X 14
107	P8688107	GIB STRIP
108	P8688108	COMPOUND REST
109	P8688109	POSITIONING PIN
110	PSB06M	CAP SCREW M6-1 X 25
111	P8688111	CLAMPING LEVER
112	P8688112	TOOL REST
113	P8688113	STUD M10-1.5 X 65
114	P8688114	CROSS FEEDING SCREW
115	P8688115	BRACKET
116	PSB23M	CAP SCREW M4-.7 X 12
119	P8688119	SPECIAL NUT M18
120	P8688120	MACHINE ID LABEL
121	P8688121	GEAR CHANGE WARNING LABEL
122	P8688122	SWITCH LABEL
123	P8688123	CONTROL BOX
124	P8688124	PLUG W/CORD
125	P8688125	RUBBER FOOT
126	P8688126	CHIP TRAY
127	P8688127	BRACKET
128	PK52M	KEY 3 X 3 X 15
129	P8688129	LEAD SCREW
130	P8688130	INDICATOR TABLE LABEL
131	P8688131	BRACKET
133	PSB56M	CAP SCREW M3-.5 X 10
134	P8688134	RACK
135	P8688135	CLAMP PLATE
136	PW04M	FLAT WASHER 10MM
137	PSS34M	SET SCREW M5-.8 X 16
138	P8688138	TAILSTOCK CASTING
139	P8688139	TAILSTOCK SCREW
140	P8688140	BRACKET
141	PSB17M	CAP SCREW M4-.7 X 10
142	P8688142	TAILSTOCK QUILT
143	P8688143	CENTER
144	P8688144	STUD M8-1.25 X 40
145	P8688145	CLAMP
146	P8688146	HANDLE
148	P8688148	PULLEY
150	P8688150	MOTOR

REF	PART #	DESCRIPTION
151	P8688151	COVER
152	P8688152	RUBBER PIPE
153	P8688153	REAR SPLASH GUARD
154	P8688154	F/N/R LABEL
155	P8688155	H/L LABEL
156	P8688156	WARNING LABEL
157	P8688157	GEAR 30T
158	P8688158	GEAR 35T
159	P8688159	GEAR 40T
160	P8688160	GEAR 45T
161	P8688161	GEAR 50T
162	P8688162	GEAR 55T
163	P8688163	GEAR 57T
164	P8688164	GEAR 60T
165	P8688165	GEAR 65T
166	P8688166	EXTERNAL JAWS (SET)
167	P8688167	3 JAW CHUCK KEY
168	P8688168	RUBBER PAD
169	P8688169	BRACING
170	P8688170	FLAT HD SCR M3-.5 X 5
171	P8688171	CLAMP BLOCK
172	PR36M	EXT RETAINING RING 7MM
173	PS09M	PHLP HD SCR M5-.8 X 10
174	P8688174	PROTECTOR
175	PSB50M	CAP SCREW M5-.8 X 10
176	PN01M	HEX NUT M6-1
177	PSB06M	CAP SCREW M6-1 X 25
178	P05161137	E-STOP SWITCH
179	P8689136	FUSE BOX
180	P8689134	SPEED CONTROL KNOB
181	P8688181	F/O/R SWITCH
182V2	P8688182V2	PC BOARD 3 TERMINALS V2.09.08
183	P8688183	ELECTRIC FILTER
200	P8688200	OIL CAN
201	P8688201	HEX WRENCH SET
202	PWR810	WRENCH 8 X 10
203	PWR1417	WRENCH 14 X 17
204	P8688204	FUSE 3A
205	P8688205	FACE PLATE
206	P8688206	STEADY REST
207	P8688207	LATHE DOG
208	P8688208	MOTOR BRUSH

WARNING

Safety labels warn about machine hazards and ways to prevent injury. The owner of this machine **MUST** maintain the original location and readability of the labels on the machine. If any label is removed or becomes unreadable, **REPLACE** that label before using the machine again. Contact Grizzly at (800) 523-4777 or www.grizzly.com to order new labels.



FOLD ALONG DOTTED LINE



Place Stamp Here



GRIZZLY INDUSTRIAL, INC.
P.O. BOX 2069
BELLINGHAM, WA 98227-2069



FOLD ALONG DOTTED LINE

Send a Grizzly Catalog to a friend:

Name _____
Street _____
City _____ State _____ Zip _____

TAPE ALONG EDGES--PLEASE DO NOT STAPLE



WARRANTY CARD

Name _____
 Street _____
 City _____ State _____ Zip _____
 Phone # _____ Email _____ Invoice # _____
 Model # _____ Order # _____ Serial # _____

The following information is given on a voluntary basis. It will be used for marketing purposes to help us develop better products and services. **Of course, all information is strictly confidential.**

1. How did you learn about us?

Advertisement Friend Catalog
 Card Deck Website Other:

2. Which of the following magazines do you subscribe to?

<input type="checkbox"/> Cabinetmaker & FDM	<input type="checkbox"/> Popular Science	<input type="checkbox"/> Wooden Boat
<input type="checkbox"/> Family Handyman	<input type="checkbox"/> Popular Woodworking	<input type="checkbox"/> Woodshop News
<input type="checkbox"/> Hand Loader	<input type="checkbox"/> Precision Shooter	<input type="checkbox"/> Woodsmith
<input type="checkbox"/> Handy	<input type="checkbox"/> Projects in Metal	<input type="checkbox"/> Woodwork
<input type="checkbox"/> Home Shop Machinist	<input type="checkbox"/> RC Modeler	<input type="checkbox"/> Woodworker West
<input type="checkbox"/> Journal of Light Cont.	<input type="checkbox"/> Rifle	<input type="checkbox"/> Woodworker's Journal
<input type="checkbox"/> Live Steam	<input type="checkbox"/> Shop Notes	<input type="checkbox"/> Other:
<input type="checkbox"/> Model Airplane News	<input type="checkbox"/> Shotgun News	
<input type="checkbox"/> Old House Journal	<input type="checkbox"/> Today's Homeowner	
<input type="checkbox"/> Popular Mechanics	<input type="checkbox"/> Wood	

3. What is your annual household income?

\$20,000-\$29,000 \$30,000-\$39,000 \$40,000-\$49,000
 \$50,000-\$59,000 \$60,000-\$69,000 \$70,000+

4. What is your age group?

20-29 30-39 40-49
 50-59 60-69 70+

5. How long have you been a woodworker/metalworker?

0-2 Years 2-8 Years 8-20 Years 20+ Years

6. How many of your machines or tools are Grizzly?

0-2 3-5 6-9 10+

7. Do you think your machine represents a good value? Yes No

8. Would you recommend Grizzly Industrial to a friend? Yes No

9. Would you allow us to use your name as a reference for Grizzly customers in your area?

Note: We never use names more than 3 times. Yes No

10. Comments: _____

CUT ALONG DOTTED LINE

WARRANTY AND RETURNS

Grizzly Industrial, Inc. warrants every product it sells for a period of **1 year** to the original purchaser from the date of purchase. This warranty does not apply to defects due directly or indirectly to misuse, abuse, negligence, accidents, repairs or alterations or lack of maintenance. This is Grizzly's sole written warranty and any and all warranties that may be implied by law, including any merchantability or fitness, for any particular purpose, are hereby limited to the duration of this written warranty. We do not warrant or represent that the merchandise complies with the provisions of any law or acts unless the manufacturer so warrants. In no event shall Grizzly's liability under this warranty exceed the purchase price paid for the product and any legal actions brought against Grizzly shall be tried in the State of Washington, County of Whatcom.

We shall in no event be liable for death, injuries to persons or property or for incidental, contingent, special, or consequential damages arising from the use of our products.

To take advantage of this warranty, contact us by mail or phone and give us all the details. We will then issue you a "Return Number," which must be clearly posted on the outside as well as the inside of the carton. We will not accept any item back without this number. Proof of purchase must accompany the merchandise.

The manufacturers reserve the right to change specifications at any time because they constantly strive to achieve better quality equipment. We make every effort to ensure that our products meet high quality and durability standards and we hope you never need to use this warranty.

Please feel free to write or call us if you have any questions about the machine or the manual.

Thank you again for your business and continued support. We hope to serve you again soon.



grizzly.com[®]

TOOL WEBSITE

Buy Direct and Save with Grizzly[®] – Trusted, Proven and a Great Value!
~Since 1983~

*Visit Our Website Today For
Current Specials!*

**ORDER
24 HOURS A DAY!
1-800-523-4777**

