

Grindmaster 115 and 250 Series Coffee Grinders

Operation and Instruction Manual

for

Models 115A, 115AB, 250, 250A, 250AB & 250-3A

Table of Contents

Installation Instructions	2
Set-up Procedures.....	2
How to Operate	2
Timer Adjustment.....	3
Grind Selector™	4
Coffee Grind Profile, Grind Adjustment	5
Current, Protection, Circuit Breaker	5
Lubrication	5
Cleaning Instructions	6
Removal and Reinstallation of Upper Hopper Assembly	6
Shear Disc Replacement.....	7
Troubleshooting Guide	8-9
Exploded Views	10-12
Wiring Diagram.....	13-15



Model 250



Model 115

***Prior authorization must be obtained
from Grindmaster Corporation for all
warranty claims.***



GRINDMASTER™
CORPORATION

Grindmaster Corporation™
4003 Collins Lane
Louisville, Kentucky 40245 USA
(502) 425-4776 (800) 695-4500
(800) 568-5715 (Technical Service)
FAX (502) 425-4664
www.grindmaster.com

Installation Instructions

1. Please read this manual before operating the grinder.
2. Carefully remove grinder from carton.
3. Place grinder in position on shelf, counter or flat surface.
4. Plug grinder into standard electrical outlet. Avoid using an extension cord.
5. Grind a small amount of whole bean coffee following operating instructions as described in this manual.
6. If there is any problem, consult the *Trouble Shooting Guide* in this manual and also on the back of your grinder.
7. If you still cannot correct a problem, call Grindmaster Corporation's Technical Service Department for help, **(800) 568-5715 M-F 8 AM - 6 PM EST.**

Instructions

Your new coffee mill is easy to operate and maintain. Before you place it in service, please have all personnel familiarize themselves with these instructions; then keep this manual in a convenient place for ready reference.

Set-up Procedures

1. You, the user, must determine the quantity of coffee you want to dispense as various types of coffee and brewing equipment require different quantities to obtain a quality cup of fresh ground, fresh brewed coffee.

Note: Because of the inherent properties of some decaffeinated coffee, it may be necessary to dispense a slightly greater amount to achieve the desired level of flavor extraction as in regular coffee. This should be evaluated based on the coffee you use as well as the brewing equipment used.
2. Adjust the timer inside the grinder if necessary, to dispense the desired weight of ground coffee (see Timer Adjustment Section on page 3). All grinders are factory set to deliver approximately 2 ounces of ground coffee. This weight is approximate, as the density of all coffee beans is not the same. The only way to ensure the desired portion is being dispensed is to weigh the coffee after it has been ground.
3. The grind texture can be adjusted, if necessary, to a finer or coarser grind (see "Grind Adjustment" section on page 5). The grind is factory set to deliver a standard autodrip grind.

How to Operate

1. Fill the hopper with the appropriate amount of whole bean coffee.
2. Place the brew basket with coffee filter on rails (or basket arms).
3. Choose the type of coffee you wish to grind by pressing the rocker selection switch.
4. Push the start button on the front of the grinder.
5. When grinder stops, remove the brew basket.

Timer Adjustment

The Timer is preset at the factory, but should adjustments be required, follow the instructions below to set the grind times.

Note: The grinder power must remain ON for timer adjustments.

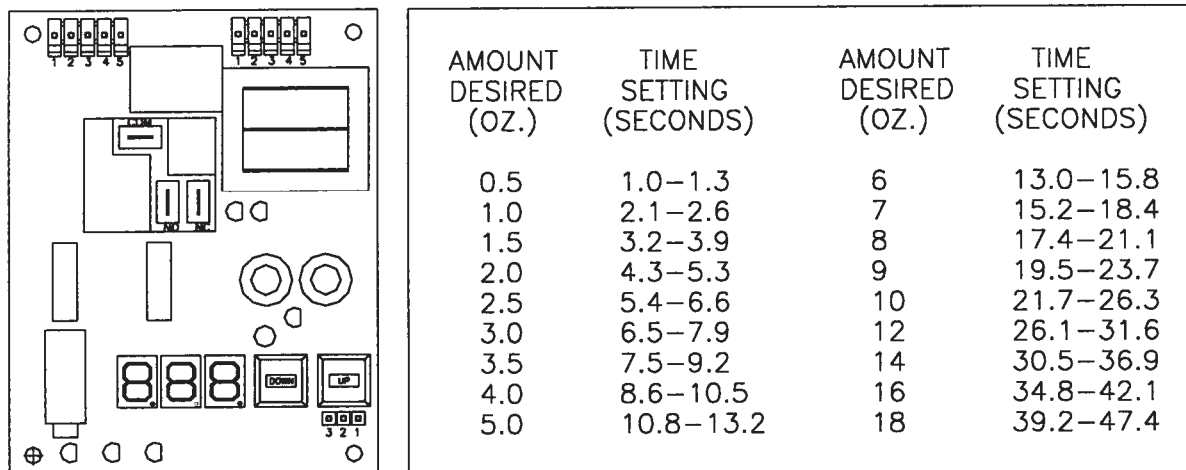

Figure A

Digital Grinder Timer Adjustments (All Models)

- To access timer, remove the timer cover by removing the mounting screws and pulling the cover away from the casing.
- To light up the display on the board and check the time setting, depress either one of the two square buttons located next to the display one time.
- To change the displayed setting, press and hold either the left or right square button until the desired setting is reached. The left button lowers the displayed value; the right button increases the displayed value. The time values are set in seconds and tenths of a second.

115 SERIES				
MODEL:	PORTION SIZE		GRIND SELECTOR:	
	LARGE	SMALL	LARGE Coarse	SMALL Fine
115A	●	●		
115AB			●	●

250 SERIES											
MODEL:	250 SERIES DECAF						250 SERIES REGULAR				
	PORTION SIZE			PORTION SIZE			PORTION SIZE				
	LARGE	MEDIUM	SMALL	LARGE	MEDIUM	SMALL	LARGE	MEDIUM	SMALL		
250		●			●			●			
250A	●		●	●		●			●		
250-3A	●	●	●	●	●	●	●	●	●		
W/GRIND SELECTOR:	LARGE		MEDIUM		SMALL		LARGE		MEDIUM		SMALL
	Coarse	Fine	Coarse	Fine	Coarse	Fine	Coarse	Fine	Coarse	Fine	Coarse
250AB	●				●		●			●	

- Refer to Figure A above for approximate timer settings.

Note: For accuracy you must weigh the coffee and make appropriate adjustments.

- In order to store this desired value you must press the grinder start switch once.

Note: If start switch is not pushed, the last value stored will be used when you return to grinding mode.

- Once the timer is adjusted, reinstall the timer cover.

Grind Selector™

For Models 115AB and 250AB

Models equipped with a Grind Selector are designated with a “B” at the end of the model number (Model 115AB & 250AB). If your grinder is equipped with a Grind Selector, refer to the following information: The Grind Selector allows you to set the grinder to coarse or fine on any of the 250AB four grind selections: regular small, regular large, decaf small or decaf large.

The following are some recommended use conditions:

Coarser Settings

Larger portions - 8 oz or more
(urns)
Decaffeinated coffee

Regular Settings

Smaller portions - 7 oz. or less
(bottle brewers or airpots)
Regular coffee

The fine grind setting on this grinder has been pre-set at the factory to deliver coffee ground to normal drip specifications. Should you wish to make an adjustment please follow these steps:

To Adjust the Fine Grind

For Models 115AB and 250AB

Tools Required: Adjustable Wrench, Phillips Screw Driver, Large Blade Screwdriver

1. Unplug grinder.
2. Remove upper front plate.
3. Loosen the fine grind adjusting screw lock nut (refer to Figure B).
4. Hold solenoid shut while turning adjusting screw clockwise to make the grind finer, counter-clockwise to make the grind coarser (refer to Figure B). We recommend that you do not turn the adjusting screw more than two notches on the scale before testing the new grind setting.

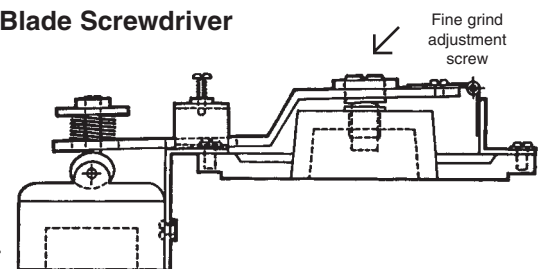

Figure B: Fine Grind Adjustment

NOTE: Be sure that when adjusting the grind that you do not adjust too fine, causing the burrs to touch each other (a sound of metal scraping metal). This could cause damage to the burrs or motor.

5. After the adjustment has been made, tighten adjusting screw lock nut. Do not allow the fine grind adjusting screw to expose more than three threads on the outer side of the arm or it could loosen during operation.
6. Assemble front plate to front of the grinder.

To Adjust the Coarse Grind

For Models 115AB and 250AB

Tools Required: Adjustable Wrench, Phillips Screw Driver, Large Blade Screwdriver

1. Unplug grinder.
2. Remove upper front plate.
3. Loosen the fine grind adjusting screw lock nut (refer to Figure C).
4. Pull the solenoid plunger toward you until it contacts the coarse grind adjusting screw. (refer to Figure C) Then turn the adjusting screw clockwise to make the grind finer, counter-clockwise to make the grind coarser. We do not recommend that you turn the adjusting screw more than one and a half turns before testing the new grind setting.
5. After the adjustment has been made, tighten the adjusting screw lock nut.
6. Assemble front plate to front of grinder.

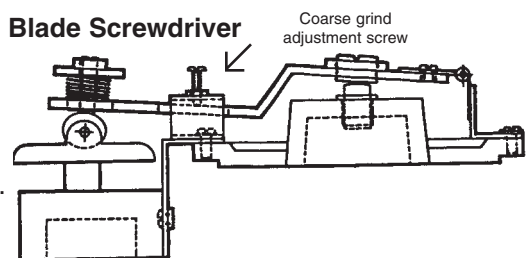

Figure C: Coarse Grind Adjustment

The following section pertains to all models.

Coffee Grind Profile

Before shipment, this grinder has been tested with coffee and has been accurately adjusted to deliver a standard autodrip grind.

The Grinding Burrs are made of an extremely hard and wear resistant alloy. From time to time, grind adjustments (see instructions below) may be necessary as the burrs wear. If the grind runs coarser than expected after normal adjustment and the grind time has increased, the burrs may have excess wear and should be replaced. The burrs are warranted for 3 years or 30,000 pounds of coffee. See your warranty for details. New burrs should always be installed as a pair, never one or the other, as they are accurately ground and lapped in pairs. Old burrs cannot be resharpened.

Grind Adjustment

For Models 115A, 250, 250A

Tools Required: Phillips and Large Blade Screwdrivers, Pliers

In order to adjust the grind follow these steps: (refer to Figure D)

1. Remove Upper Front Plate by removing the four screws in the corners.
2. Loosen Adjusting Screw Lock Nut by turning counter clockwise.
3. Turn slotted Adjusting Screw clockwise to make grind finer or counter-clockwise to make grind coarser. Generally a 1/8 to 1/4 turn will provide the desired adjustment.

Note: Use dial on grinder cap as reference. Do not turn more than one notch before testing new Grind Adjustment.

4. After adjustment has been made, tighten Adjusting Screw Lock Nut.
5. To visually inspect grind adjustment, test grind a small portion of coffee and re-adjust if necessary.

Note: Adjusting the grind may alter the portion of coffee dispensed. After grind adjustment, weigh portion and adjust, if necessary (see "How to Adjust the Portion").

Current

It is absolutely essential that full voltage and amperage always be available as it takes full power to grind coffee. NEVER connect to an overloaded line or a two or three way plug, otherwise serious damage to the motor may result. **Do not use an extension cord.**

Protection

This grinder is equipped with both a circuit breaker and a shear disc release to protect motor and burrs if a foreign object, such as a nail or rock, gets into the coffee.

Circuit Breaker

This grinder is equipped with a circuit breaker to protect the motor from overloading. When the circuit breaker operates, the reset button will pop out approximately 1/4" which cuts Off the power to the grinder. The reset button is located above the power cord on the back of the grinder. To reset the circuit breaker, push the reset button in. You will hear a click as it resets. If the grinder does not operate after resetting the circuit breaker, there may be an obstruction in the grinding mechanism that is stalling the motor. In this case, the Grinder Head should be cleaned out as described in the **Shear Disc Replacement** section of this manual.

Lubrication

All bearings have been oiled for life. No further oiling is necessary.

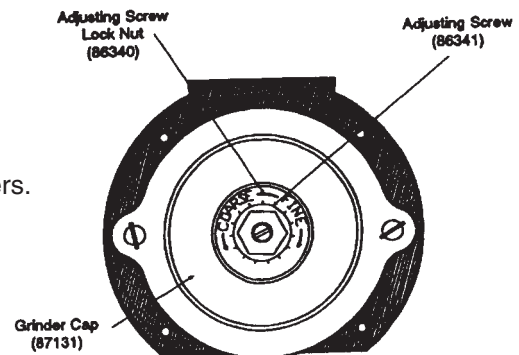

Figure D: Grind Adjustment

Cleaning Instructions

The outside of the machine can be cleaned with a damp cloth or common household polishing wax. Grinding parts should be cleaned with a stiff brush or dry cloth. **Do Not Use Water.** See “Shear Disc Replacement” for instructions on assembling and disassembling of grinder parts. Before reassembling, wipe motor shaft with 2 or 3 drops of common household lubricating oil in the area of feedworm engagement to make assembly easier.

Removal and Reinstallation of Hopper Assembly

1. Remove Upper Front Plate by removing the four screws in the corners (**Shipping bracket must be removed prior to removal of upper hopper assembly. See instructions and diagram below.**)
2. Lift Upper Hopper Assembly while rotating the Assembly slightly upward (refer to Figure E).
3. Pull the Assembly forward, toward front of unit and out.

Figure E: Upper Hopper Assembly Removal and Reinstallation

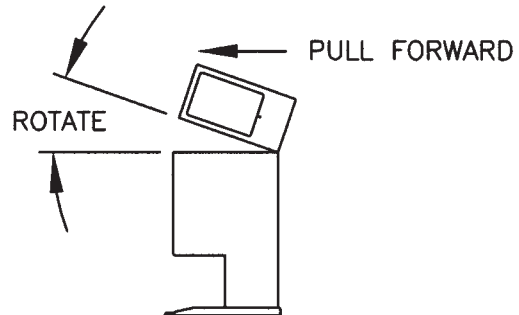

Shipping Bracket Removal

Models 250, 250A and 250AB are equipped with shipping bracket. Remove bracket prior to installation. (See Figure F)

Tools Required: 1 Phillips screwdriver.

- a. Using the Phillips screwdriver, remove the screws and the bracket located at the back of the grinder.
- b. Do not discard the screws and bracket. The bracket should be re-installed on the grinder prior to transporting or shipping.

The bracket may be left on grinder, but must be removed prior to servicing.

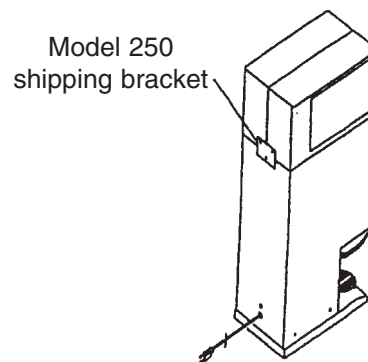

Figure F: Shipping Bracket Removal

Hopper Reinstallation

For Models 250, 250A and 250AB

1. Ensure the Drive Pins are in vertical position. (See figure G)
2. Ensure that Drive Links are in horizontal position.
3. Insert the rear slots of the Upper Hopper Assembly into the rear tabs of the motor bracket.
4. Rotate Assembly downward.
5. Reassemble Upper Front Plate.
6. Put the (4) screws back into Upper Front Plate and tighten.

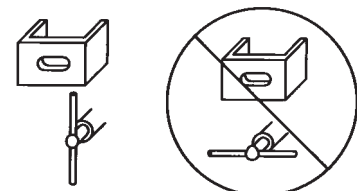

Figure G: Positioning of the Drive Pins and Drive Links

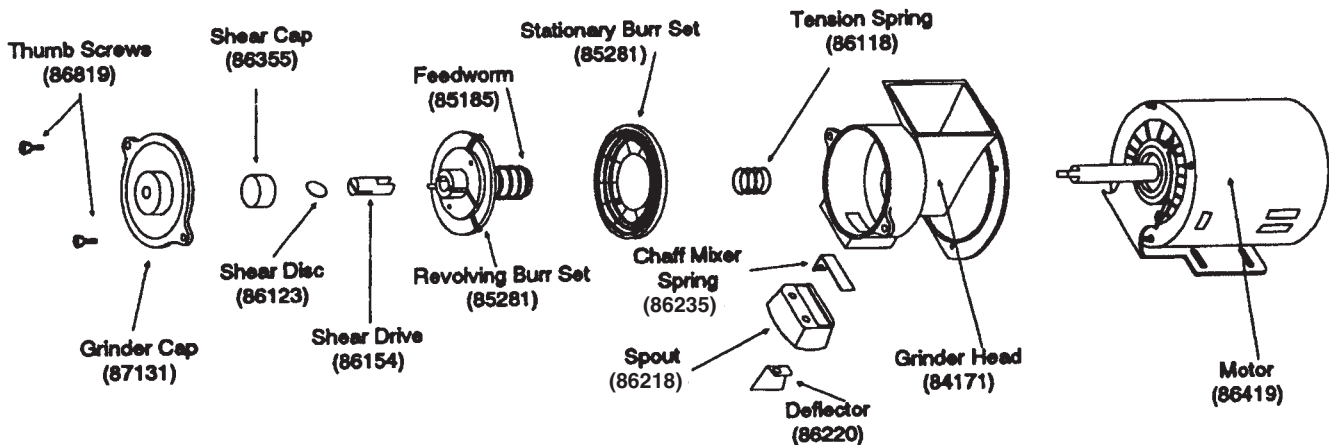

Figure H: Grinder Head Mechanism

Shear Disc Replacement

If the motor should run and no coffee is dispensed, the shear disc release may have operated. Should this occur, perform the following operations in the sequence given (refer to Figure H).

Tools Required: Phillips Screwdriver and Pliers

1. Unplug machine.
2. Remove the Upper Front Plate of the grinder to provide access to the grinder mechanism.
3. Remove the Grind Cap by taking out the 2 Thumb Screws.
4. Pull out the Revolving Burr and Feedworm Assembly. Clean out the Grinder Head, removing all coffee particles from inside of the Grinder Head and the Grinder Cap so that it can be reset properly.
5. Check that no obstruction has been caught on the surface of the teeth of either burr.
6. Remove the Shear Cap and broken pieces of the Shear Disc. You are now ready to reassemble the grinder mechanism.
7. Slide the Burr and Feedworm Assembly back onto the Motor Shaft making certain that the tongue of the shaft engages the slot in the Shear Drive.
8. Insert a new Shear Disc by aligning the slot in the Shear Drive with the slot in the hub of the Feedworm.
9. Reassemble the Shear Cap and Grinder Cap. Make certain the Grinder Cap is screwed on tight and is sealed properly against the head, not cocked. Otherwise a proper grind cannot be obtained.
10. Reassemble the Upper Front Plate. Your grinder is now ready to grind.

Troubleshooting Guide

The following procedures must be performed by a qualified service technician.

CAUTION: Unplug the machine before cleaning or servicing the unit.

Problem	Possible Cause	Solution
Grinder will not start when Start button is pushed.	<ul style="list-style-type: none"> • Plug not in outlet properly. • No power to outlet. • Circuit breaker has tripped 	<ul style="list-style-type: none"> • Install plug in outlet. • Check outlet with lamp or radio to verify outlet has power. • Reset circuit breaker by pushing in reset button until you hear a click.
Grinder runs or hums but no coffee is dispensed.	<ul style="list-style-type: none"> • Shear disc is broken. • Obstruction in opening to grinding chamber. • Auger has stalled (models 250 & 250A only). 	<ul style="list-style-type: none"> • Replace shear disc. See “Shear Disc Replacement” section or instructions on inside of upper front plate. • Remove hopper and clear obstructions. • Clean auger.
Excessive amount of chaff flying about.	<ul style="list-style-type: none"> • Defective chaff mixer spring. • Static electricity. 	<ul style="list-style-type: none"> • If bent, broken, or missing, replace spring. • If stuck open with coffee, clean coffee to free spring. • Tighten all nuts, bolts and screws and verify outlet is grounded.
Quantity of coffee dispensed each throw is not the same.	<ul style="list-style-type: none"> • Auger stalls (Models 250 & 250A only). • Timer delay is not working or running long enough. • Defective timer. 	<ul style="list-style-type: none"> • Refer to problem as listed below in this Troubleshooting Guide. • See “Timer Adjustment” section. • Check the length of time the grinder runs. • If time varies more than plus or minus 1%, replace timer.
Knobs do not operate smoothly.	<ul style="list-style-type: none"> • Coffee beans or bean dust may have clogged carrier. 	<ul style="list-style-type: none"> • With machine unplugged, clean carrier.
Auger does not turn.	<ul style="list-style-type: none"> • Coffee beans or bean dust may have jammed auger. 	<ul style="list-style-type: none"> • With machine unplugged, clean auger opening.
Auger will not operate.	<ul style="list-style-type: none"> • Motor or link is binding. • Auger motor has burned out. • Wiring harness to motor is loose. 	<ul style="list-style-type: none"> • Check all alignment of link and motor. Check tightness of motor mounting screws. • Replace motor • With machine unplugged, check to see if wires are connected to motor.
Circuit breaker continuously trips.	<ul style="list-style-type: none"> • Insufficient current due to use of extension cord. • Insufficient current due to overloaded line. • Grind setting needs adjustment. 	<ul style="list-style-type: none"> • Plug unit directly into outlet. Do not use extension cord. • Designate single line for grinder. Do not use multi-outlet box. • Adjust grind to coarser setting (see “Grind Adjustment” section)

Troubleshooting Guide for Grind Selector™ Mechanism (Models 115AB and 250AB)

The following procedures must be performed by a qualified service technician.

PROBLEM	POSSIBLE CAUSE	SOLUTION
Loud grating noise.	<ul style="list-style-type: none"> Burrs are touching each other on fine grind setting. 	<ul style="list-style-type: none"> Readjust fine grind setting, see “To Adjust Fine Grind” section.
Rumbling noise.	<ul style="list-style-type: none"> Thrust bearing rotating inside flange bearing. 	<ul style="list-style-type: none"> Replace thrust bearing and shear cap.
Chattering or buzzing noise.	<ul style="list-style-type: none"> Solenoid may have failed to seat or close fully. 	<ul style="list-style-type: none"> Check alignment of solenoid and shift arm. Also check the tightness of the solenoid mounting screws.
Loud vibration noise during grinding when Grind Selector™ is not activated.	<ul style="list-style-type: none"> Cotter pin in the thumb screw linkage may be vibrating. 	<ul style="list-style-type: none"> Attempt to spread flanges of cotter pin or replace cotter pin.
Grind Selector™ fails to activate.	<ul style="list-style-type: none"> Wiring harness loose. Solenoid has burned out. 	<ul style="list-style-type: none"> WITH MACHINE UNPLUGGED, check wiring harness connections to see if they are secure on the timer terminals. Replace solenoid.

If you still need help, call our Service Department at (800) 568-5715 (Monday through Friday 8am-6pm EST) or an authorized service center in your area. Please have the model and serial number ready so that accurate information can be given.

Prior authorization must be obtained from Grindmaster Corporation’s Technical Services Department for all warranty claims.

Models 115A, 115AB & 250 Series Exploded Views

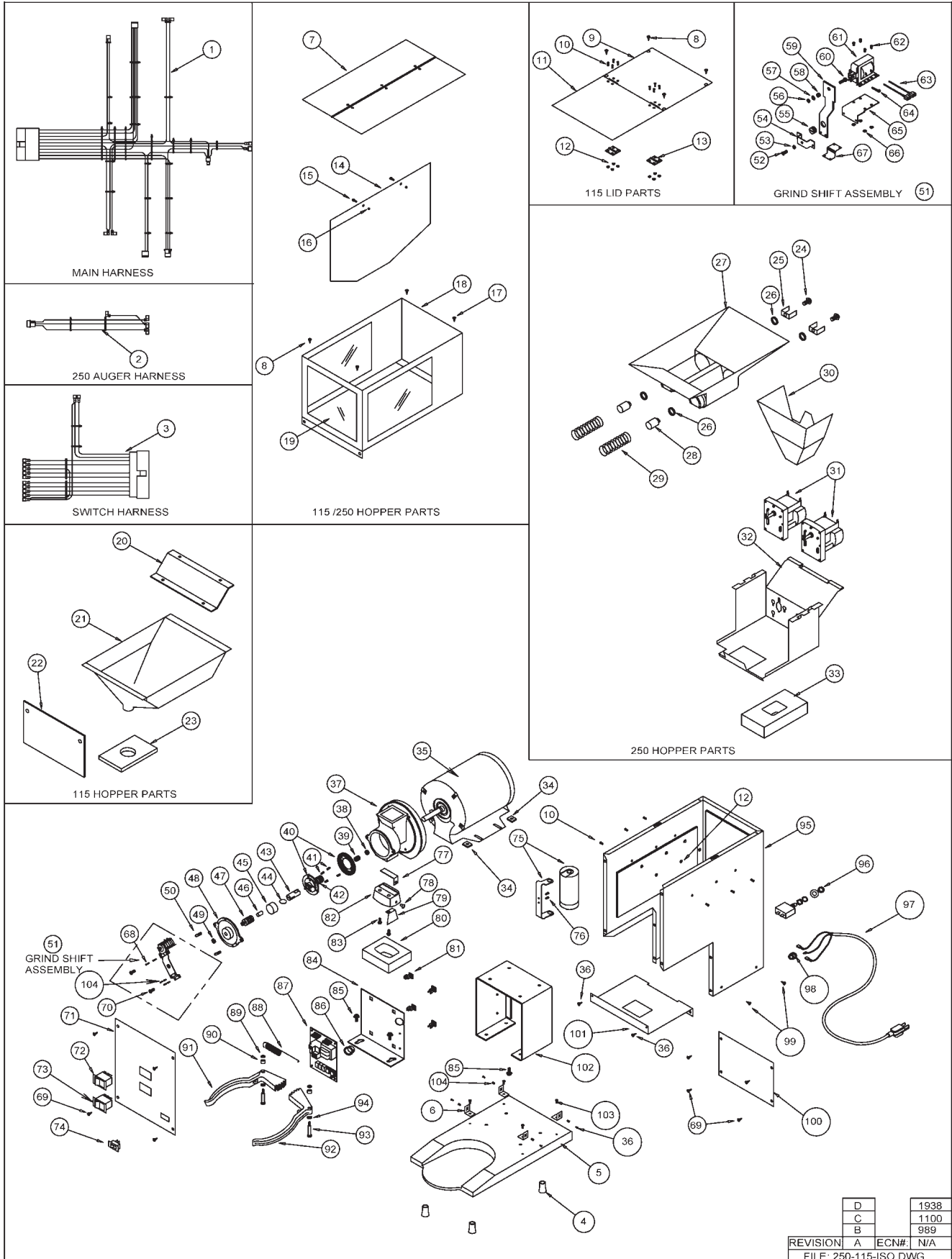

D	1938
C	1100
B	989
REVISION A	ECN#: N/A
FILE: 250-115-ISO.DWG	

Parts List Description

ITEM	DESCRIPTION	115A	115AB	250	250A	250AB
1	HARNESS, 115/250 A & AB	86037	86037	86037	86037	86037
2	HARNESS, 250 SERIES DIGITAL AUGER			86125	86125	86125
3	HARNESS, DIGITAL SWITCH	86122	86122	86121	86117	86117
4	FOOT, RUBBER 100/250	86034	86034	86034	86034	86034
5	BASE	86309	86309	86309	86309	86309
6	ANGLE BRACKET, GRINDER BASE	86862	86862	86862	86862	86862
7	250 LID ASSEMBLY			89103K	89103K	89103K
8	SCREW, #8 X 3/8 PH PN SMS T/B 410 SS	89113	89113			
9	LID, BACK SS	86013	86013			
10	SCREW, 6-32 X 1/4 PH PN HD	86801	86801			
11	LID, FRONT SS	86014	86014			
12	NUT, 6-32 ACORN LOCK	86848	86848			
13	HINGE, PLATED	86316	86316			
14	PARTITION, HOPPER			86041	86041	86041
15	SCREW, 8-32 1/2 SL BD HD NYLON			86087	86087	86087
16	NUT, 8-32 NYLON LOCK			86086	86086	86086
17	SCREW, #8 X 3/8 PH PN SMS T/B 410 SS	89114	89114			
18	HOPPER	86010K	86010K	86010K	86010K	86010K
19	WINDOW, HOPPER	86102	86102	83152	83152	83152
20	HOPPER, SUPORT	86008	86008			
21	HOPPER	86192	86192			
22	FRONT HOPPER SUPPORT	86196K	86196K			
23	GASKET, HOPPER	86228	86228			
24	SCREW, 8-32 X 3/8" HEX PEM			83182	83182	83182
25	LINK, DRIVE			83368	83368	83368
26	WASHER, NYLON			83141-01	83141-01	83141-01
27	HOPPER, AUGER W/ SPOUT			83150	83150	83150
28	ADAPTER, DRIVE			80019	80019	80019
29	SPRING, AUGER			86046	86046	86046
30	FUNNEL, AUGER			83134	83134	83134
31	MOTOR, AUGER 230V			86000	86000	86000
32	BRACKET, MOTOR			86042-01	86042-01	86042-01
33	GASKET, HOPPER			83081	83081	83081
34	NUT, TINNEMAN 1/4 - 20	86864	86864	86864	86864	86864
35	MOTOR, 1/2HP 230V 50 HZ	86421	86421	86421	86421	86421
36	SCREW, 8-32 X 3/8 PH TR HD M/S 410 SS	82097	82097	82097	82097	82097
37	HEAD, GRIND	84171S	84171S	84171S	84171S	84171S
38	COLLAR, THRUST	86304	86304	86304	86304	86304
39	SPRING, TENSION	86118	86118	86118	86118	86118
40	BURR (SET)	85281W	85281W	85281W	85281W	85281W
41	SCREW, #10-32 X 5/16	86812	86812	86812	86812	86812
42	FEEDWORM	85185T	85185T	85185T	85185T	85185T
43	DRIVE, SHEAR	86154	86154	86154	86154	86154
44	SHEAR DISC	86123	86123	86123	86123	86123
45	COVER, SHEAR	86355	86355	86355	86355	86355
46	BEARING, ADJUSTING	86140	86140	86140	86140	86140
47	GRIND, ADJUST PIN	86341	86341	86341	86341	86110
48	GRIND, CAP	87131	86112	87131	87131	86112
49	NUT, 5/8-18 BRASS ADJUST SCREW	86340		86340	86340	
50	SCREW, 5/16-18 X 1 THUMB T/S ZINC	86819		86819	86819	
51	GRIND SHIFT ASSEMBLY 230VAC		89005			89005
52	SCREW, 8-32 X 5/8 PH TR M/S ZINC		86899			86899
53	NUT, 8-32 KEPS ZINC PLATED		86810			86810
54	BRACKET, COARSE STOP		86115			86115
55	SCREW, GRIND ADJUST 5/8-18 X 3/8		86111			86111

Parts List Description (cont.)

ITEM	DESCRIPTION	115A	115AB	250	250A	250AB
56	NUT, 1/4-20 X 7/16 HEX JAM ZINC PLATED		86892			86892
57	WASHER, FLAT 1/4 - ZINC PLATED		86824			86824
58	SPRING, TENSION		86118			86118
59	SHIFT, ARM		86114			86114
60	SCREW, 1/4-20 X 3/4 THUMB ZINC		86089			86089
61	SOLENOID, GRIND SHIFT 230V 50HZ		86534-02K			86534-02K
62	SCREW, #8 X 1/4 PH TR HD SMS T/B 410 SS		89116			89116
63	HARNESS, SOLENOID		86048			86048
64	PIN, COTTER 3/32 X 1 ZINC PLATED		86853			86853
65	BRACKET, SOLENOID MTG		86116			86116
66	NUT, 8-32 KEPS ZINC PLATED		86810			86810
67	ASSEMBLY, GRIND SHIFT HINGE A225-28-1		86107			86107
68	SCREW, 8-32 X 3/8 SL BD HD M/S ZINC		86807			86807
69	SCREW, #8 X 1/4 PH TR HD SMS T/B 410 SS	89116	89116	89116	89116	89116
70	SCREW, 5/16-18 X 1 SL FIL HD M/S		86887			86887
71	PLATE, FRONT	86007	86007	86007	86006	86006
72	SWITCH, DECAF / REGULAR ROCKER			86075	86075	86075
73	SWITCH, PORTION ROCKER	86075	86075		86075	86075
74	SWITCH, ROCKER START	70445	70445	70445	70445	70445
75	CAPACITOR, 230V W/ BRACKET	86179	86179	86179	86179	86179
76	SCREW, 8-32 X 1/2	86808	86808	86808	86808	86808
77	SPRING, CHAFF MIXER	86146	86146	86146	86146	86146
ALT 77	SPRING, W/ CHAFF SUPPRESSION	86235	86235	86235	86235	86235
78	SCREW, 4-40 X 1/4 PH PN HD ZINC	86148	86148	86148	86148	86148
79	DEFLECTOR	86220	86220	86220	86220	86220
80	GASKET, HOPPER FUNNEL	71419	71419	71419	71419	71419
81	STANDOFF, REVERSE EDGEMOUNT	61266	61266	61266	61266	61266
82	SPOUT	86218	86218	86218	86218	86218
83	SCREW, 8-32 X 3/8 PH RD HD	86217	86217	86217	86217	86217
84	BRACKET, CONTROL BOARD	86038	86038	86038	86038	86038
85	BOLT, 1/4-20 HX HD	86872	86872	86872	86872	86872
86	BUSHING, HEYCO OPEN / CLOSED	86039	86039	86039	86039	86039
87	DIGITAL, TIMER	86139	86139	86139	86139	86139
88	SPRING, BASKET ARM	86508	86508	86508	86508	86508
89	NUT, WHIZLOCK 1/4-20	87049	87049	87049	87049	87049
90	SPACER	87026	87026	87026	87026	87026
91	ARM, BASKET LEFT	71014	71014	71014	71014	71014
92	ARM, BASKET RIGHT	71013	71013	71013	71013	71013
93	SCREW, 5/16 X 1 HEX SOC SHLDR	87024	87024	87024	87024	87024
94	SPACER	87025	87025	87025	87025	87025
95	CASING	86011K	86011K	86012K	86012K	86012K
96	CIRCUIT BREAKER, 5A	83107	83107	83107	83107	83107
97	POWER CORD, 1.5MM CE	61453	61453	61453	61453	61453
98	STRAIN RELIEF	86071	86071	86071	86071	86071
99	SCREW, #10 X 1/2 PH TR HD T/AB 410 SS	86859	86859	86859	86859	86859
100	PLATE, LOWER FRONT	86003	86003	86003	86003	86003
101	PLATE, SAFETY SHIELD	87032K	87032K	87032K	87032K	87032K
102	MOTOR MOUNT ASSEMBLY	86995	86995	86995	86995	86995
103	SCREW, 10-32 X 5/16 SL BD HD M/S ZINC	86812	86812	86812	86812	86812
104	REVNUT, 8-32 AKS4-832-80	82096	82096	82096	82096	82096

115A, 115AB & 250 Series Wiring Diagram 115V

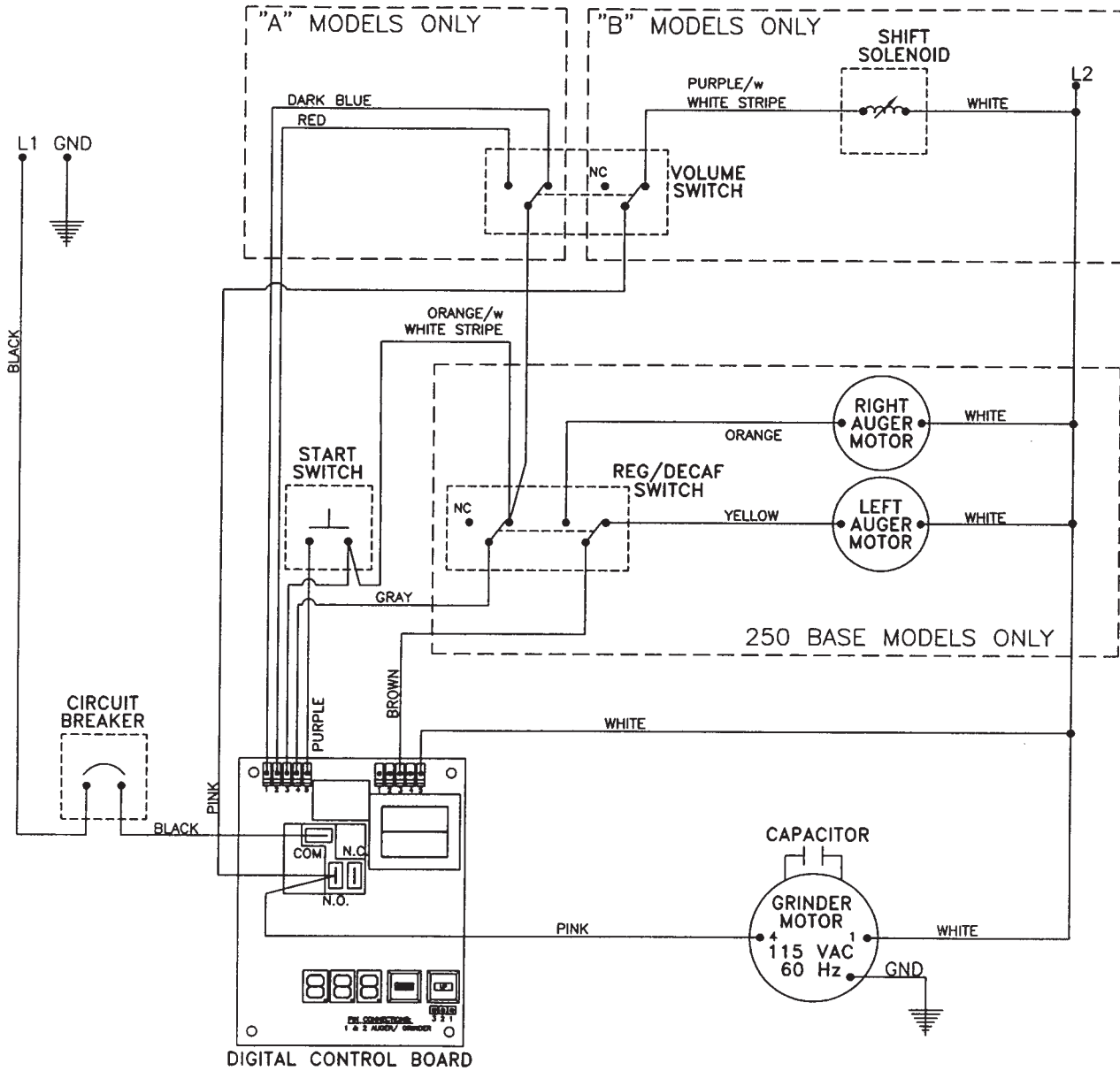

115A & 115AB/120V Exploded View

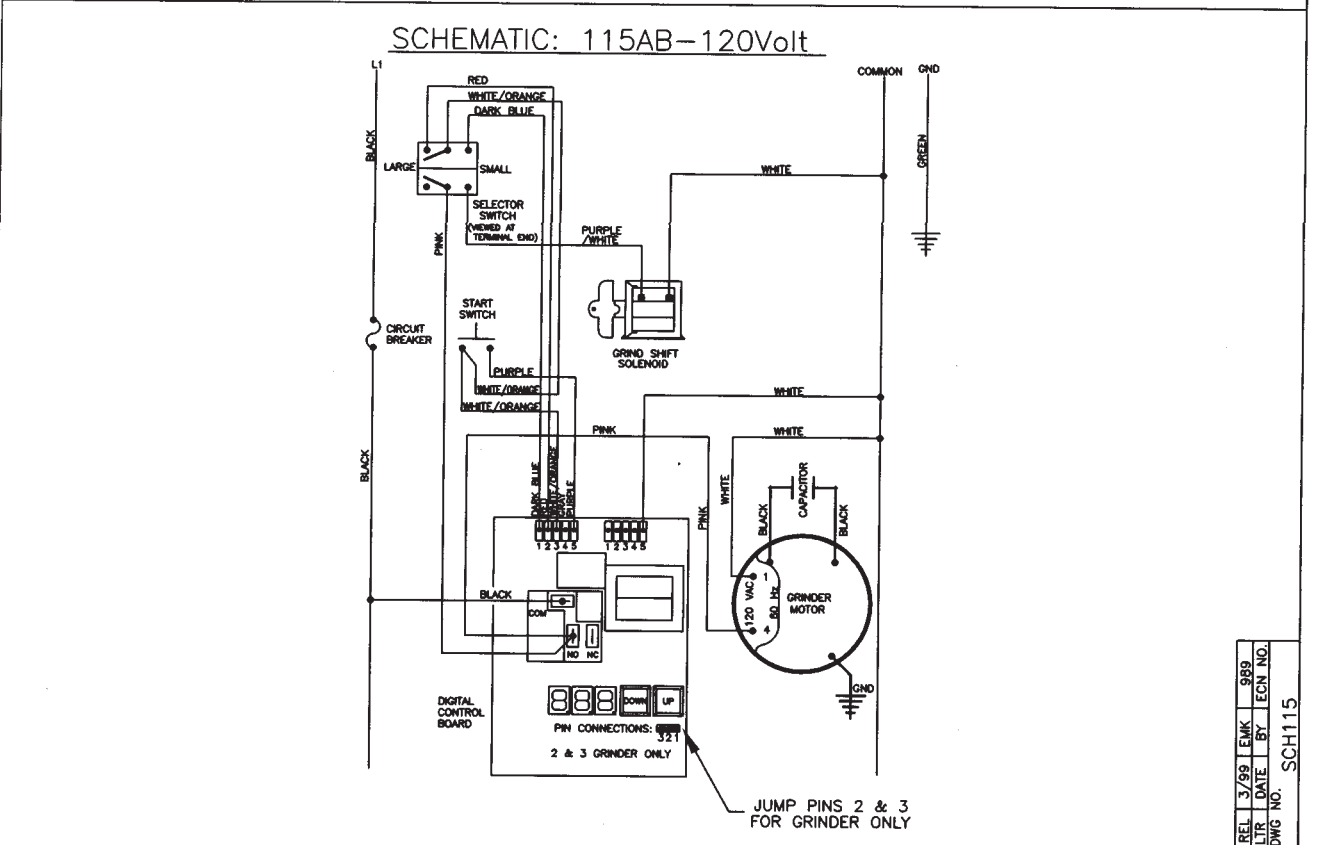
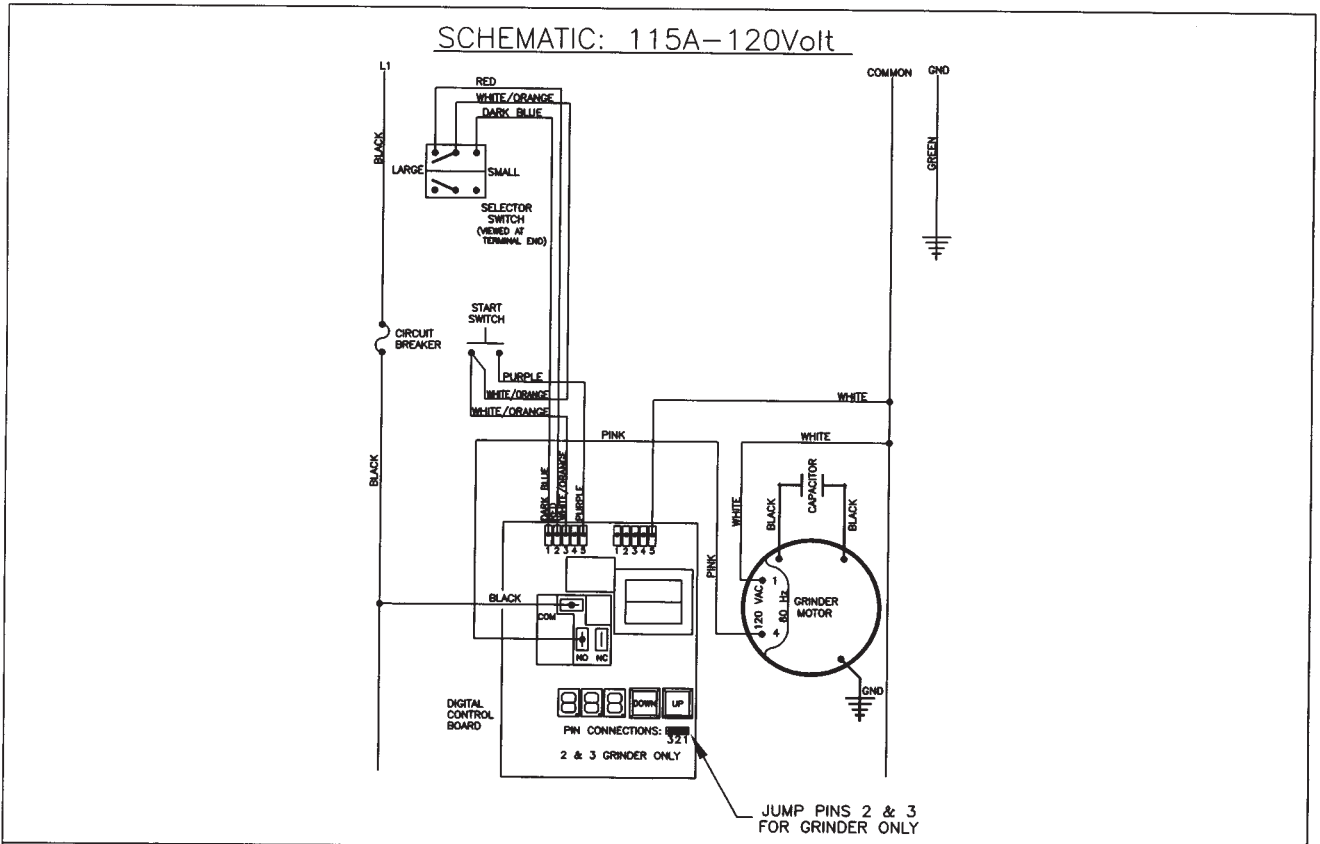

REL	3/99	EMK	989
LTR		DATE	BY
DWG	NO.	SCH	115

115A & 115AB/120V Exploded View

