

GRACO®

Toddler Bed

Owner's Manual • Please save for future use.

Lit d'enfant

Manuel d'utilisateur
Veillez garder pour usage ultérieur.

Cama infantil

Manual del propietario
Por favor, conservélo para utilizarlo en el futuro.

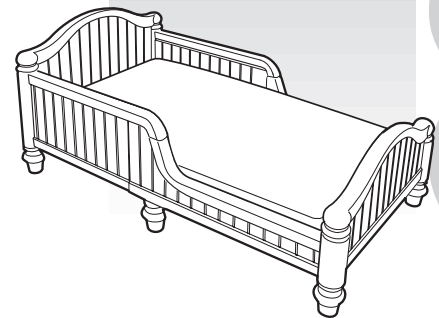

8840

Model • Modèle • Modelo: _____

Serial No. • No. de Série • N° de Serie: _____

Dear Customer,

Please fill in the model and serial numbers above from the small label on the headboard.

Thank you for purchasing this Graco® toddler bed!

Graco is the recognized leader in the design and manufacture of quality juvenile products. We believe your new Graco toddler bed is a wise choice, promising many hours of enjoyment for your child.

Before using your toddler bed, please take a few minutes to read this Owner's Manual. The short time you spend reading these instructions will help you use your toddler bed properly.

Cher Client,

Veillez inscrire ci-haut les numéros de modèle et de série que vous trouverez sur la petite l'étiquette sur la tête de lit.

Merci de votre achat de ce lit d'enfant Graco®!

Graco est le chef de file dans la conception et la fabrication de produits de qualité pour les enfants. Nous croyons que votre lit d'enfant Graco est un choix judicieux, garantissant plusieurs heures de plaisir pour votre bébé.

Avant d'utiliser le lit d'enfant, prenez quelques minutes pour lire le manuel d'utilisateur. Ce court instant que vous prendrez à lire les instructions vous aidera à utiliser correctement votre lit d'enfant.

Estimado cliente,

Por favor, escriba arriba el modelo y número de serie que están en la etiqueta de la cabecera.

¡Gracias por comprar este cama infantil Graco®!

Graco es el líder reconocido en el diseño y fabricación de productos infantiles de calidad. Creemos que su cama Graco es una compra acertada y ofrecerá a su bebé muchas horas de placer.

Antes de usar su cama, dedique unos minutos a leer este manual del propietario. El poco tiempo que emplee en leer estas instrucciones le ayudará a utilizar su cama de manera correcta.

⚠️ WARNING

Failure to follow these warnings and the assembly instructions could result in serious injury or death from entrapment or strangulation.

- **USE WITH a standard full-size crib mattress**, being at least 27¼ in. (690 mm) wide by 51⅝ in. (1310 mm) long by 4 in. (100 mm) thick.
- **DO NOT use for infants.** This bed is not a substitute for a crib. The toddler bed is intended for a child between 15 months and 5 years of age. Maximum weight 50 lbs (22.7 kg). Use the bed with only one child at a time.
- **DO NOT place bed near windows** where cords from blinds or drapes may strangle a child, or child may fall out of the window.
- **DO NOT use a water mattress** or all foam mattress with this toddler bed.
- **DO NOT use with less than 12 in.** (305 mm) of space between the side of the toddler bed and solid objects such as a wall or dresser. Child could slide into smaller spaces and suffocate.
- **STRINGS can cause strangulation.** DO NOT place items with a string around a child's neck, such as hood strings or pacifier cords. DO NOT suspend strings over a toddler bed.

⚠️ MISE EN GARDE

Manquer de suivre ces avertissements et les instructions d'assemblage peut entraîner de sérieuses blessures ou le décès par étranglement.

- **UTILISEZ AVEC un matelas de taille standard** qui mesure au moins 27,25 po (690 mm) de largeur et 51,63 po (1310 mm) de longueur et 4 po (100 mm) d'épaisseur.
- **NE PAS utiliser pour les nourrissons.** Ce lit ne remplace pas un lit de bébé. Le lit d'enfant est conçu pour un enfant de 15 mois à 5 ans. Le poids maximum est de 50 lb (22,7 kg). Utilisez le lit avec un enfant à la fois.
- **NE PAS placer le lit près d'une fenêtre.** Les cordons de stores et de rideaux peuvent étrangler un enfant, ou l'enfant peut tomber de la fenêtre.
- **NE PAS utiliser un matelas de lit d'eau** ou un matelas en mousse avec ce lit d'enfant.
- **NE PAS placer le lit à moins de 12 po (305 mm) d'espace** entre le côté du lit d'enfant et des objets solides tels un mur ou une commode. L'enfant pourrait s'y glisser et étouffer.
- **LES CORDONS peuvent causer des étranglements.** NE PAS placer d'articles attachés à un cordon autour du cou d'un enfant, tel que cordons de capuchon ou des attaches de sucette. NE PAS suspendre des cordons au-dessus d'un lit d'enfant.

⚠️ ADVERTENCIA

Si no se obedecan estas advertencias y se siguen las instrucciones de montaje podría resultar en lesiones graves o la muerte al entraparse o estrangularse.

- **USAR CON un colchón para cuna grande común** que tenga por lo menos 27 ¼ pulgadas (690 mm) de ancho por 51 ⅝ pulgadas (1.310 mm) de largo por 4 pulgadas (100 mm) de espesor.
- **NO USARLO con bebés.** Esta cama no es un sustituto de la cuna. La cama del niño es para un niño pequeño de 15 meses a 5 años de edad. Peso máximo de 50 libras (22,7 kg.). Use la cama solamente con un niño por vez.
- **NO coloque la cama cerca de ventanas** donde cordones de las persianas o cortinas pudieran estrangular al niño o el niño pudiera caerse por la ventana.
- **NO USE un colchón de agua** o colchón completamente de goma espuma con esta cama para niños pequeños.
- **NO lo use con menos de 12 pulgadas (305 mm) de espacio** entre el costado de la cama del niño pequeño y objetos sólidos tales como una pared o un vestidor. El niño podría deslizarse hacia espacios más pequeños y sofocarse.
- **LOS CORDONES pueden causar la estrangulación.** NO coloque los artículos con un cordón alrededor del cuello del niño, tales como cordones de una capucha o cordones de chupetes. NO suspenda cordones arriba de la cama de un niño pequeño.

Questions?

In the U.S.A. or Canada, please contact our Customer Service Department with any questions you may have concerning parts, use, or maintenance. When you contact us, please have your product's **model and serial numbers** ready so that we may help you efficiently.



Telephone us at:
Téléphonez-nous au:
Llámenos al:

USA: 1-800-345-4109
Canada: 1-800-667-8184
Montreal: 514-344-3533

Des questions?

Aux Etats-Unis ou au Canada, veuillez contacter notre département du service à la clientèle avec des questions que vous pourriez avoir concernant les pièces, l'utilisation ou l'entretien. Lorsque vous nous contactez, soyez prêt à fournir les **numéros de modèle et de série** afin que nous puissions vous aider plus rapidement.



or visit our website,
ou visitez notre website,
o visite nuestro sitio Web,

USA: www.gracobaby.com
Canada: www.graco.net

¿Preguntas?

En los EE.UU. y Canadá, por favor contacte a nuestro Departamento de Servicio al Cliente con cualquier pregunta que pueda tener sobre las piezas, uso o mantenimiento. Cuando nos contacte, por favor tenga el **número del modelo y número de serie** listos para que podamos ayudarlo mejor.



or write to us at:
sinon, écrivez-nous à:
o escribanos a:

USA:
Graco Children's Products Inc.
Customer Service Department
P.O. Box 100, Main Street
Elverson, PA 19520



Canada: distributed by
Elfe
4580 Hickmore
St. Laurent, Quebec H4T 1K2

Parts list

Check that you have all the parts shown **BEFORE** assembling your product. If any parts are missing, call Customer Service.

Adult assembly required.

No tools required

Liste des pièces

Assurez-vous d'avoir toutes les pièces illustrées **AVANT** de commencer l'assemblage de votre produit. S'il vous manque des pièces, communiquez avec notre service à la clientèle.

Assemblage par un adulte requis.

Aucun outil requis

Lista de las piezas

Verifique que cuenta con todas las piezas mostradas **ANTES** de montar su producto. Si falta alguna pieza, llame al Departamento de Servicio al Cliente.

Se requiere montaje por un adulto.

No herramientas necesarias

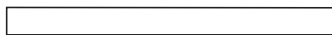
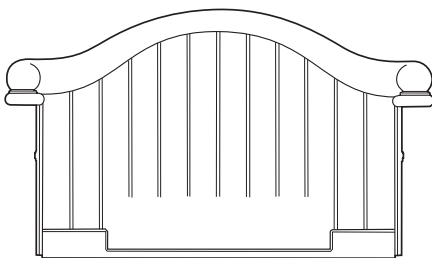

4X

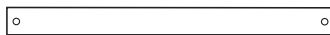

1X

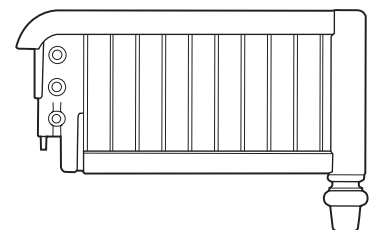
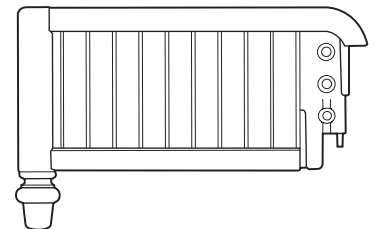
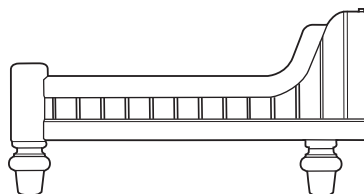
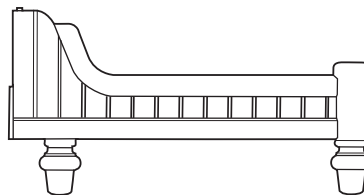
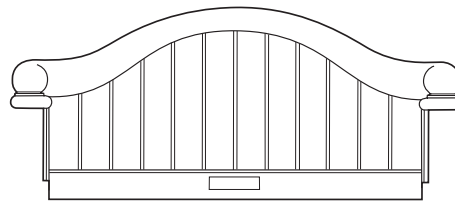

Assembly

This exploded view is provided as a way to help you see the overall picture as you are assembling your product. It is not meant to replace the step-by-step instructions.

Assemblage

Cette illustration agrandie est fournie pour vous aider à voir l'image totale lors de l'assemblage de votre produit. Cette illustration ne doit pas remplacer les instructions étape par étape.

Montaje

Se proporciona este plano detallado para darle una perspectiva global del montaje de su producto. No está destinado a remplazar las instrucciones paso por paso.

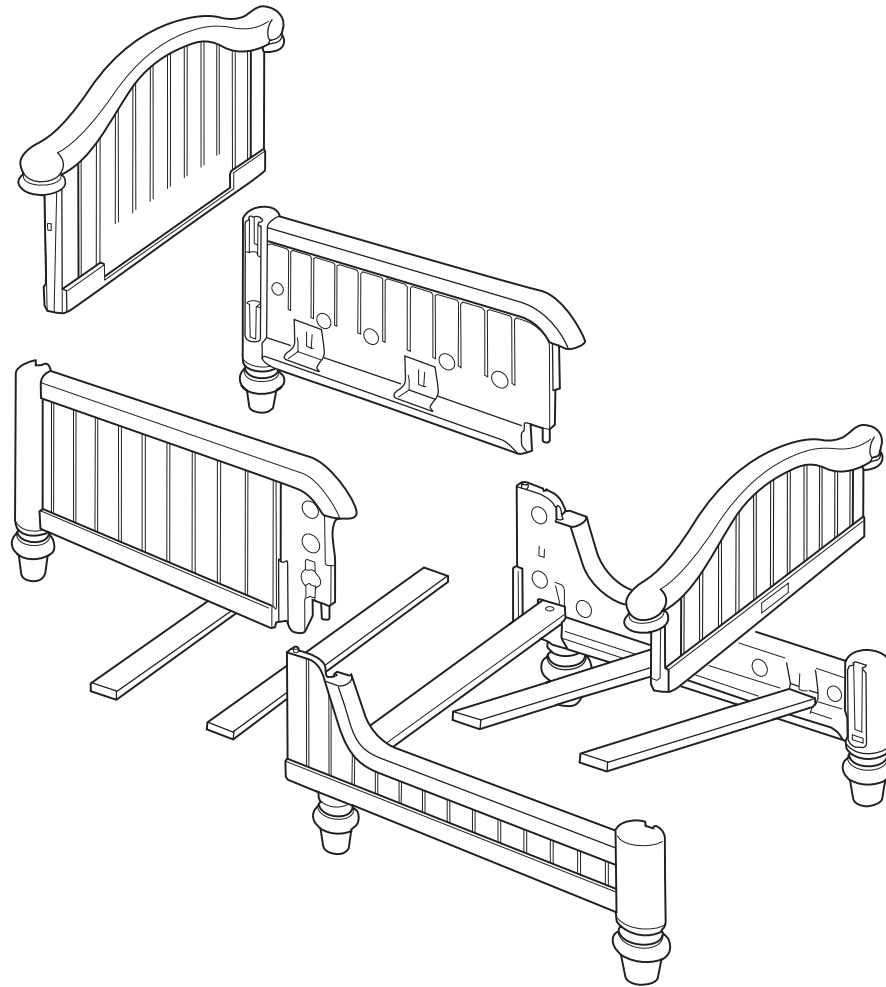

Care and Maintenance

BEFORE ASSEMBLY AND EACH USE, inspect bed for damaged hardware, loose joints, missing parts or sharp edges. **DO NOT** use bed if any parts are missing or damaged. **DO NOT** substitute parts. Use only Graco replacement parts.

TO CLEAN BED FRAME, use only household soap and warm water. **NO BLEACH** or detergent.

Soins et entretien

AVANT L'ASSEMBLAGE ET AVANT CHAQUE UTILISATION, inspectez le lit pour de la quincaillerie défectueuse, jointures desserrées, pièces manquantes et coins pointus. **NE PAS** utiliser le lit s'il vous manque des pièces ou qu'elles sont endommagées. **NE PAS** substituer les pièces. Utilisez seulement les pièces de remplacement Graco.

POUR NETTOYER L'ARMATURE DE LIT, utilisez seulement du savon de ménage avec de l'eau tiède. **AUCUN AGENT DE BLANCHIMENT** ou détergent.

Cuidado y mantenimiento

ANTES DE ARMARLA Y DE CADA USO, inspeccione la cama para determinar si hay herrajes dañados, uniones flojas, piezas que faltan y bordes filosos. **NO** use la cama si falta o está dañada alguna pieza. **NO** sustituya las piezas. Use solamente repuestos Graco.

PARA LIMPIAR EL ARMazón DE LA CAMA, use solamente jabón de uso doméstico y agua tibia. **NO USAR CLORO** o detergente.

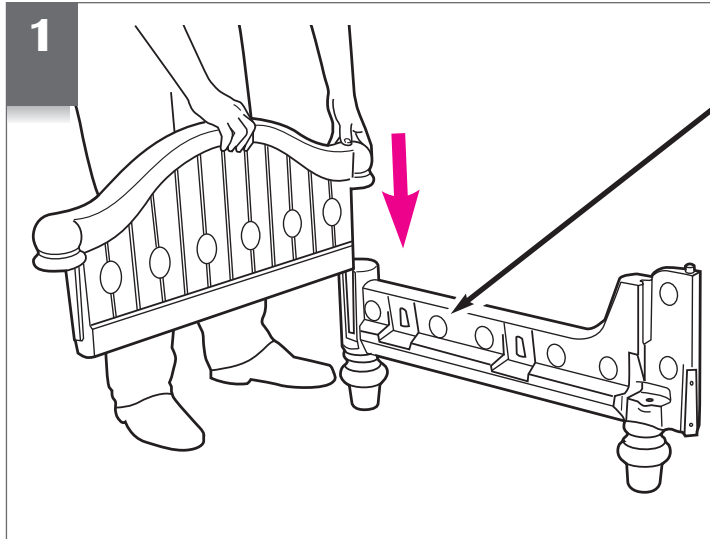
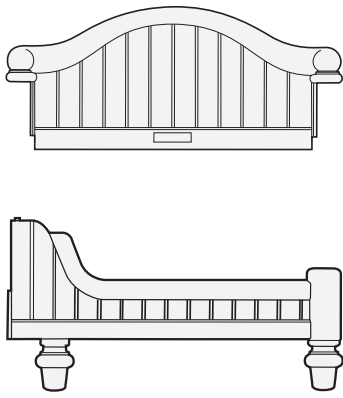

Round indentations go toward the **inside** of the bed, **except on the headboard**.

Les renforcements arrondis vont vers **l'intérieur** du lit, **exceptez sur la tête de lit**.

Las hendiduras redondas miran hacia el **interior** de la cama, **excepto en la cabecera**.

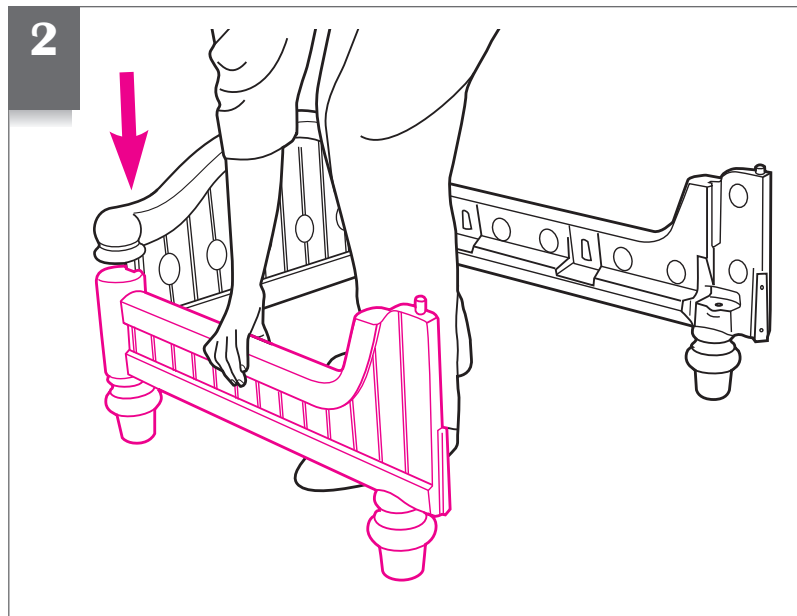
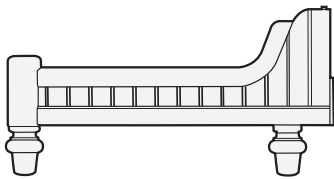

3

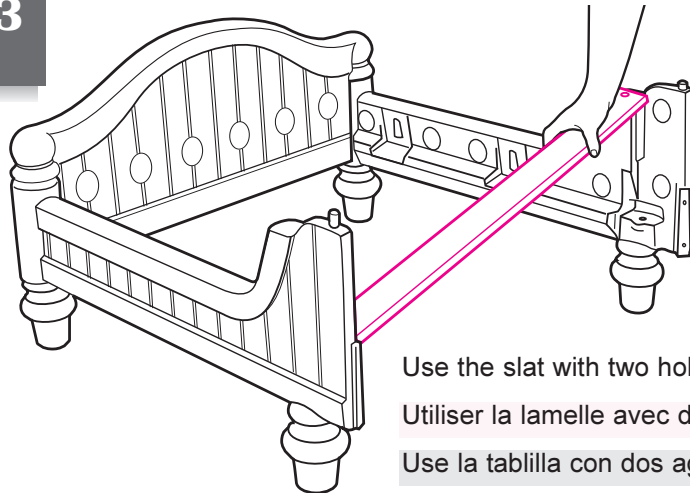

Use the slat with two holes.
Utiliser la lamelle avec deux trous.
Use la tablilla con dos agujeros.

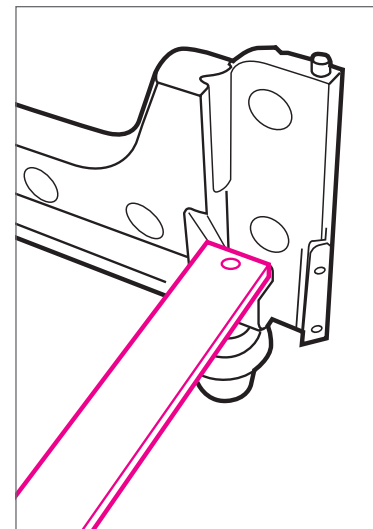

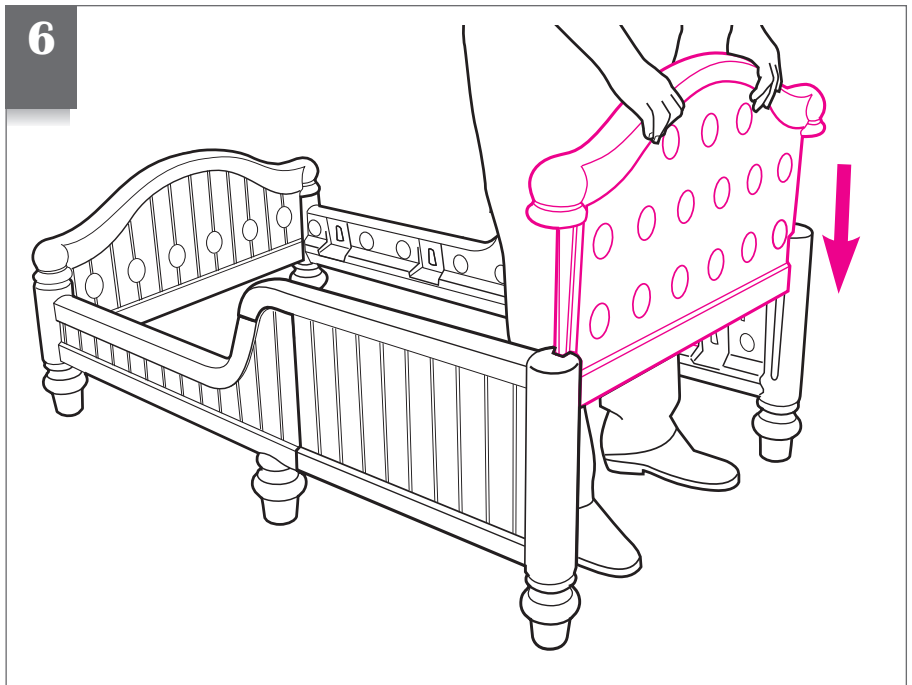
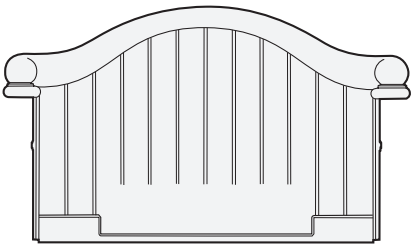
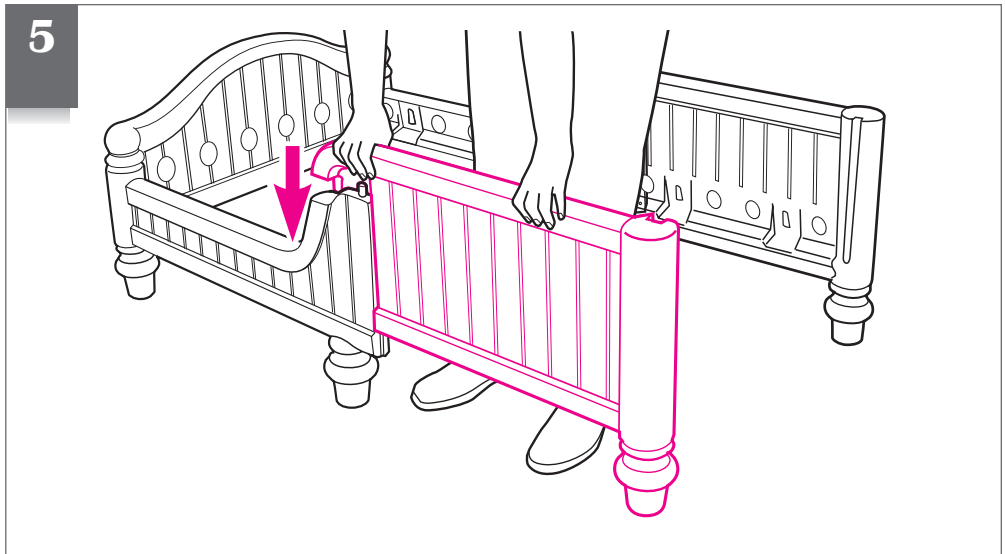
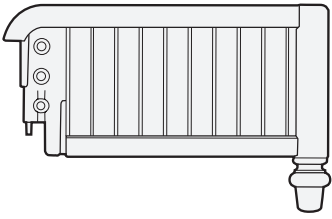
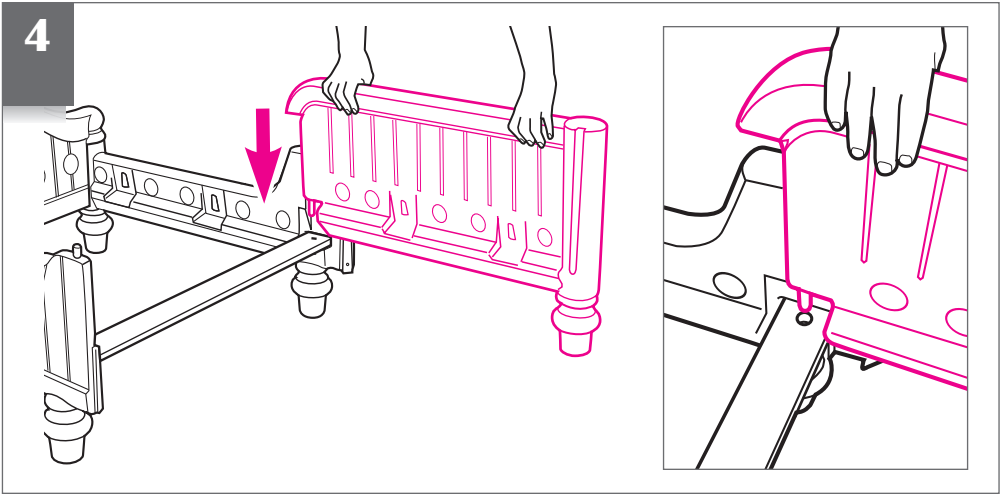
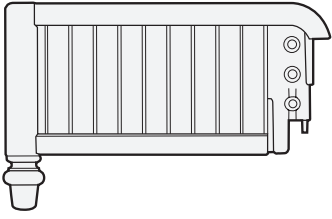

7

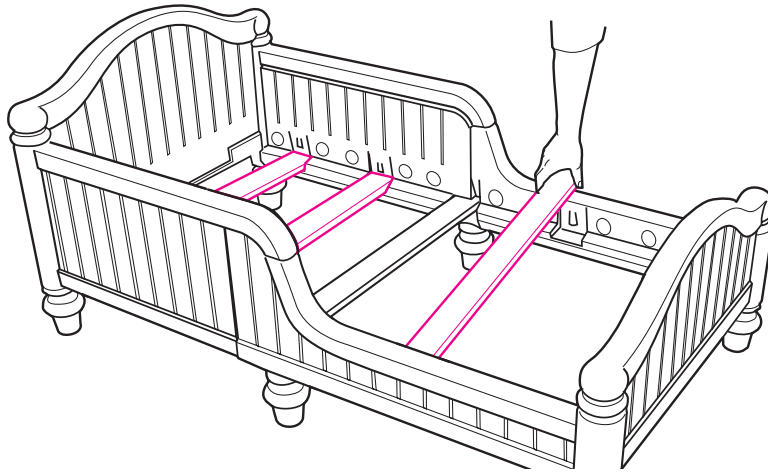

4X

8

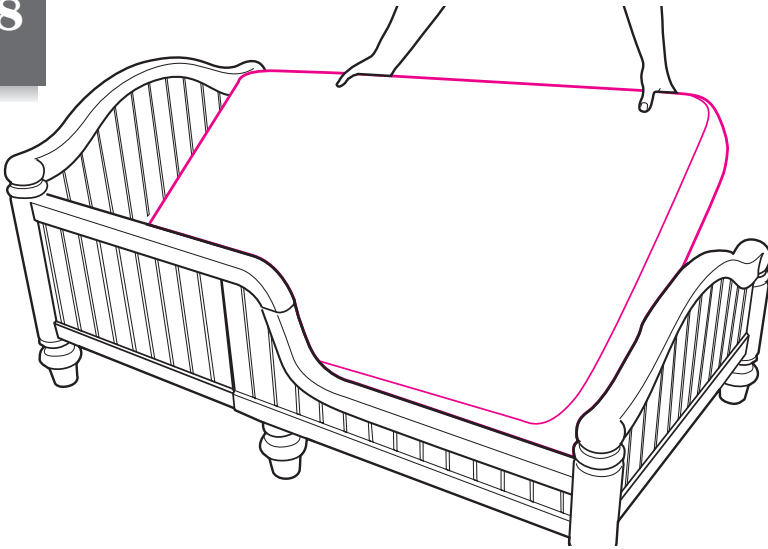

▲WARNING Use a full-size crib mattress, being at least 27¼ in. (690 mm) in width, 51⅝ in. (1310 mm) in length, and 4 in. (100 mm) in thickness.

▲MISE EN GARDE Utilisez un matelas de taille standard pour lit de bébé qui mesure au moins 27,25 po (690 mm) de largeur et 51,63 po (1310 mm) de longueur et 4 po (100 mm) d'épaisseur.

▲ADVERTENCIA Usar con un colchón para cuna grande común que tenga por lo menos 27 ¼ pulgadas (690 mm) de ancho por 51 ⅝ pulgadas (1.310 mm) de largo por 4 pulgadas (100 mm) de espesor.

9

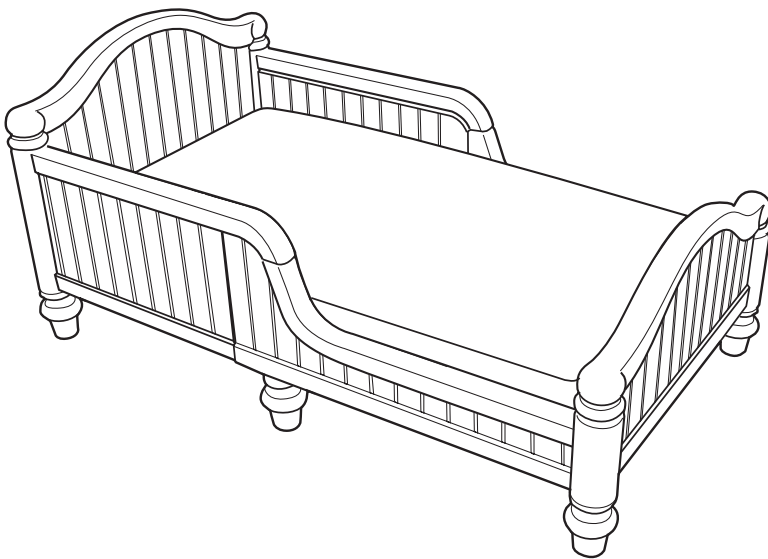

Replacement Parts (USA)

Complete the form below. Your toddler bed model number **MUST** be included on the form to ensure proper replacement parts. **Your model number can be found on a label on the headboard. Payment must accompany your order.**

Return the form with payment to:
GRACO Children's Products Inc.
Customer Service Department
P.O. BOX 100, Main Street
Elverson, PA 19520



Questions? Telephone us at: • ¿Preguntas? Llámenos al:

1-800-345-4109

Piezas de repuesto (EE.UU)

Complete el formulario a continuación. El número de modelo de su cama infantil **DEBE** incluirse en este formulario para asegurarse de que recibirá las piezas de repuesto apropiadas. **El número de modelo puede encontrarse en la etiqueta de la cabecera. El pago en dólares estadounidenses debe incluirse con el pedido.**

Devuélvase con pago a:
GRACO Children's Products Inc.
Customer Service Department
P.O. BOX 100, Main Street
Elverson, PA 19520

Replacement Parts (Canada)



To purchase parts in Canada, contact Elfe at
1-800-667-8184
 (Montreal: 514-344-3533
 Fax: 514-344-9296).

Des pièces de remplacement (au Canada)



Pour commander les pièces au Canada, communiquez avec Elfe au
1-800-667-8184
 (Montréal: 514-344-3533
 Fax: 514-344-9296).

- Circle the part you need.
- Marque con un círculo el repuesto que necesita.

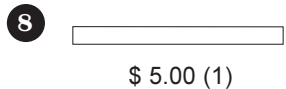
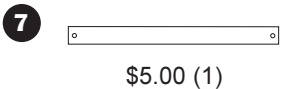
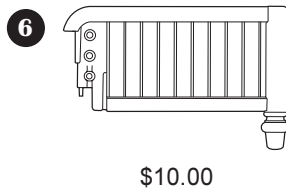
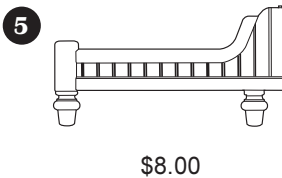
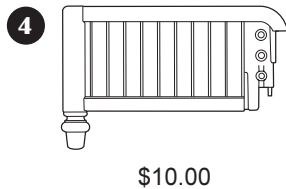
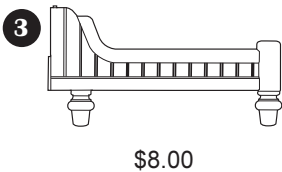
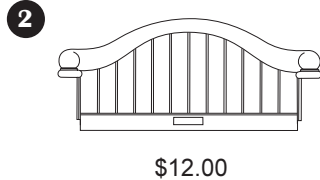
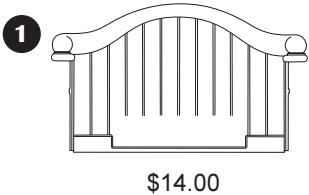

Must be filled in: Debe completarse:

Model No.
N° de modelo

Serial No.
N° de serie

Total • Total:

Shipping & handling*:
Gastos de envío*: \$5.00

Sales tax**:
Impuestos**:

Total due:
Total a pagar:

*\$15.00 outside the continental U.S.
 *US\$ 15,00 para fuera del continente de EE.UU
 **CA 6%, IL 6.25%, IN 5%, NY 8.25%,
 OH 5.75%, PA 6%, SC 5%

Ship to • Enviar a:

Name • Nombre

Address • Dirección

City, State, Zip • Ciudad, Estado, Código postal

Telephone • Teléfono

Check or money order enclosed
 (payable to Graco Children's Products Inc.)
 Cheque o giro adjunto
 (a nombre de Graco Children's Products Inc.)

Charge to credit card • Cargar a la tarjeta de crédito
 Account #: • Cuenta N°:

Visa
 Mastercard
 Discover

Exp. date • Fecha de vencimiento:
 Signature • Firma:



Thank you for your purchase of a Graco product. Your input regarding this product is very important to us.

Return this card today to:

1 REGISTER YOUR PRODUCT

We will keep the model number, serial number, and date of purchase of your Graco product on file.

2 RECEIVE FUTURE INFORMATION

By returning this card, you will help us to notify you of any issues concerning this product.

3 HELP US DEVELOP NEW PRODUCTS

We value your input. Your responses will help us develop new products specifically designed to meet your needs.

DETACH HERE BEFORE MAILING

IMPORTANT! Product Registration Card IMPORTANT!

238 A

1 1. Mr. 2. Mrs. 3. Ms. 4. Miss

First Name: _____ Initial: _____ Last Name: _____

Address: (Number and Street) _____ Apt. #: _____

City: _____ State: _____ Zip Code: _____

2 Phone #: _____

4 Store Name: _____

6 Record Model Number and Serial Number: (These can be found on the white label on the product)

Model Number _____

Serial Number _____

7 Was this purchase a:
1. Gift? 2. Self purchase?

8 Is this your first child?
1. Yes 2. No

9 In what trimester was your purchasing decision made?
1. 1st 2. 2nd 3. 3rd

10 This child is:
1. Male 2. Female

11 How did you first hear about this Graco product?
1. Word of Mouth 5. Store Flyer
2. Salesperson 6. Catalog
3. In-Store Display 7. Other
4. Magazine Ad

12 Check the three (3) most important reasons why you purchased this Graco product:
1. Received as a Gift
2. Fabric Design / Appearance
3. Frame Design / Style
4. Graco Reputation
5. Recommendation of Salesperson
6. Recommendation of Friend / Family
7. Value for Price
8. Magazine Advertisement
9. Ease of Operation
10. Light Weight
11. Product Features
12. Sale / Promotion
13. Prior Experience with Graco

13 What other brands did you consider?
1. Graco was the only brand considered
2. Century 6. Fisher Price
3. Combi 7. Gerry
4. Cosco 8. Other _____
5. Evenflo

14 Have you purchased Graco products before?
1. Yes 2. No

3 I am a:
1. Parent 2. Grandparent

5 Date of Purchase: _____
Month Day Year

15 Where do you and your family do most of your shopping?
1. Shopping Mall
2. Discount Store
3. Specialty Store

16 Baby's date of birth: (or due date) _____
Month Day Year

17 Date of Your birth: _____
Month Day Year

18 For your primary residence, do you:
1. Own? 2. Rent?

19 Your marital status:
1. Married 2. Single

20 Education (Please check which category applies):
1. High School 3. Completed College
2. Some College 4. Graduate School

21 Including yourself, what is the total number of people living in your household?
____ (Examples: 01, 02, 03, 04...)

22 NOT including yourself, what are the AGES of the other people living in your household?
Age (in years)
Male: _____
Female: _____

23 Which best describes your family income?
1. Under \$15,000 5. \$50,000-\$74,999
2. \$15,000-\$24,999 6. \$75,000-\$100,000
3. \$25,000-\$34,999 7. \$100,000-\$149,999
4. \$35,000-\$49,999 8. Over \$150,000

24 In the last 6 months have you or your spouse:
1. Purchased clothes through the mail?
2. Purchased gifts through the mail?
3. Worked in your garden?
4. Traveled on vacation?
5. Purchased through television shopping?
6. Purchased two or more books?
7. Purchased cassettes or CDs?
8. Donated to wildlife / environmental causes?
9. Donated to charities?

Thanks for taking time to fill out this questionnaire. Please check here [] if you do not wish to learn more about Graco or obtain information on new ideas from other exciting companies.

IMPORTANT!

PRODUCT REGISTRATION CARD

THANK YOU
FOR CHOOSING

GRACO®

Please take a moment to
complete this card today to:

- ▶ REGISTER
YOUR
PRODUCT
- ▶ RECEIVE
FUTURE
INFORMATION
- ▶ HELP US
DEVELOP NEW
PRODUCTS

Please send other correspondence to:

Graco Children's Products Inc.
Main Street
P.O. Box 100
Elverson, PA 19520-0100

238 A

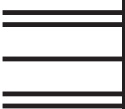

Place
First-Class
Stamp
Here
Post Office will
not deliver
without proper
postage

GRACO®

PRODUCT REGISTRATION DEPARTMENT
PO BOX 40
DENVER CO 80201-0040

