

\$1.00

# OWNER'S GUIDE

ASSEMBLY • OPERATION • MAINTENANCE • PARTS

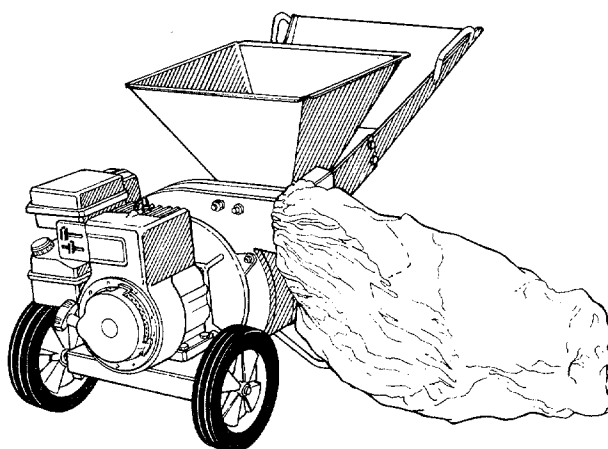

**5 H.P.  
SHREDDER**

**Model Numbers**

**240-650-000  
240650**

**Important: Read Safety Rules and Instructions Carefully**

# INDEX

Rules for Safe Operation . . . . .	3	Maintenance . . . . .	9
Assembly . . . . .	4	Off-Season Storage . . . . .	10
Operation . . . . .	6	Trouble Shooting Chart . . . . .	11
Adjustments . . . . .	8	Repair Parts . . . . .	12, 13



Instructions given with this symbol are for personal safety. Be sure to follow them.



**WARNING**

This unit is equipped with an internal combustion engine and should not be used on or near any unproved forest-covered, brush-covered or grass-covered land unless the engine's exhaust system is equipped with a spark arrester meeting applicable local or state laws (if any). If a spark arrester is used, it should be maintained in effective working order by the operator.

In the State of California the above is required by law (Section 4442 of the California Public Resources Code). Other states may have similar laws. Federal law apply on federal lands. A spark arrester for the muffler is available through your nearest engine authorized service dealer.



To reduce the potential for any injury, comply with the following safety instructions. Failure to comply with the instructions may result in personal injury.

## RULES FOR SAFE OPERATION

### TRAINING

1. Read this owner's manual carefully in its entirety before attempting to assemble or operate this machine. Be completely familiar with the controls and the proper use of this machine before operating it. Keep this manual in a safe place for future and regular reference and for ordering replacement parts.
2. Children must never be allowed to operate this equipment.
3. No one should operate this unit while intoxicated or while taking medication that impairs the senses or reactions.
4. This equipment should never be operated in the vicinity of children, pets or other persons.
5. Never run your machine in an enclosed area as the exhaust from the engine contains carbon monoxide, which is an odorless, tasteless and deadly poisonous gas.
6. Never allow your hands or any part of your body or clothing inside the feeding chamber, discharge chute, or near any moving part while the machine or engine is running.
7. If it is necessary for any reason to inspect or repair the feeding chamber or any part of the machine where a moving part can come in contact with your body or clothing, stop the machine, allow it to cool, and disconnect the spark plug wire from the spark plug before attempting such inspection or repair.

### PREPARATION

1. Wear safety glasses provided with your unit while operating the chipper-shredder to prevent injury from any chips which may be ejected out of the openings.
2. Wear proper apparel. Avoid wearing loose fitting clothing. Wear gloves when handling material.
3. **HANDLE FUEL WITH CARE** as gasoline is an extremely flammable fuel.
  - A. Check the fuel before starting the engine. Do not fill the fuel tank indoors, while the engine is running, or while the engine is still hot. Turn the unit off and let the engine cool before refueling.
  - B. Fuel your shredder in a clean area. Do not smoke while refueling.
  - C. Fuel tank cap must be secure at all times except during refueling.
  - D. Avoid spilling gasoline or oil. Wipe the unit clean of any spilled fuel or oil.
  - E. Store fuel and oil in approved containers, away from heat or open flame, and out of reach of children.
4. This machine should be operated only upon a level earthen surface.
5. Assure that all screws, nuts and bolts and other fasteners are properly secured.

### OPERATION

1. When feeding shreddable material into this equipment, be extremely careful that pieces of metal,

rocks, bottles, cans or other foreign objects are not included.

2. If the cutting mechanism strikes any foreign object or if your machine should start making an unusual noise or vibration, immediately stop the engine and disconnect the spark plug wire from the spark plug. Allow the machine to stop and take the following steps:
  - A. Inspect for damage.
  - B. Replace or repair any damaged parts.
  - C. Check for any loose parts and tighten to assure continued safe operation.
3. The engine must be kept clean of debris and other accumulations.
4. Do not allow an accumulation of processed material to build up in the discharge area as this will prevent proper discharge and can result in kick-back from feed opening.
5. Never allow your hands or any other part of your body or clothing inside the feeding chamber, discharge chute or near any moving part while the engine is running.
6. Keep all guards and deflectors in place and in good working condition to assure continued safe operation.
7. Always stand clear of the discharge area when operating this machine.
8. Keep your face and body back from the feed opening to avoid accidental bounce back of any material.
9. Do not over-reach. Keep proper balance and footing at all times.
10. The engine governor settings on your machine must not be altered, changed, or tampered with. The governor controls the maximum safe operating speeds and protects the engine and all moving parts from damage caused by overspeed.
11. Do not transport machine while engine is running.
12. Do not operate engine if air cleaner or cover directly over carburetor air intake is removed, except for adjustment. Removal of such parts could create a fire hazard.

### MAINTENANCE AND STORAGE

1. When this equipment is stopped for servicing, inspection, storage or to change an accessory, make sure the spark plug wire is disconnected from the spark plug. The machine should be allowed to cool down before making such inspection, adjustments, service, etc. Maintain your machine with care and keep it clean for the best and continued safe operation.
2. Do not use flammable solutions to clean the air filter.
3. When not in use, your machine should be stored out of the reach of children. Keep where gasoline fumes will not reach an open flame or spark. For long periods of storage, the gasoline should be drained and disposed in a safe manner. Always allow the machine to cool before storing in any enclosure.



This unit is shipped WITHOUT GASOLINE or OIL. After assembly, see separate engine manual for proper fuel and engine oil recommendations.



The right and left side of your shredder is determined from behind the unit.

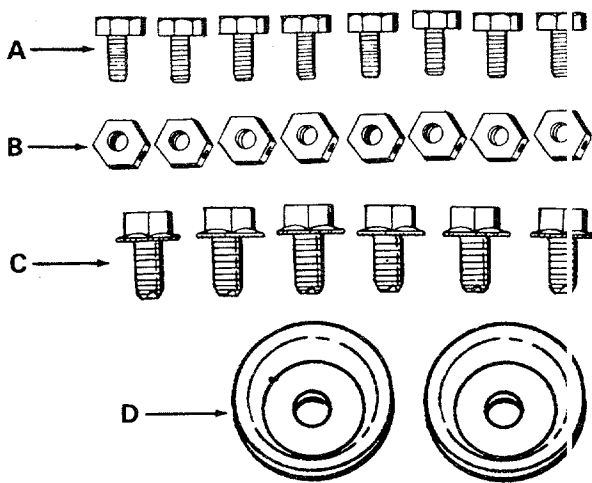

## ASSEMBLY INSTRUCTIONS

### Tools Required for Assembly:

- (2) 7/16" Open End or Box Wrenches\*
- (1) 1/2" Socket Wrench

\* An Adjustable Wrench may be used in place of one of the wrenches.

### UNPACKING

Remove the shredder and loose parts from the carton. Make certain all parts and literature have been removed before the carton is discarded.

### Parts in Carton:

Shredder  
Chute Deflector  
Hopper  
Upper Leaf Ramp Section  
Catcher Bag  
Hardware Pack

### Contents of Hardware Pack (See Figure 1):

- A (8) Hex Bolts 1/4-20 x 1/2" Long
- B (8) Hex Lock Nuts 1/4-20 Thread
- C (6) Hex Washer Head Self-Tapping Screws  
5/16-18 x 3/4" Long
- D (2) Keepers
- (1) Safety Glasses (Not Shown)

FIGURE 1.

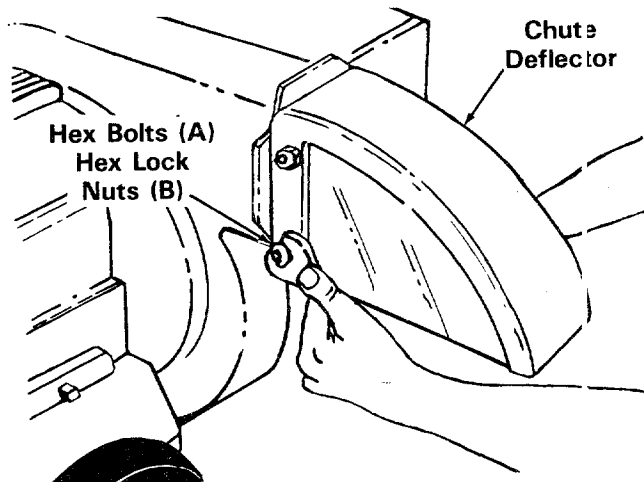

### CHUTE DEFLECTOR INSTALLATION

1. Place the chute deflector in position on the discharge opening (on the left side of the shredder). See figure 2.
2. Secure chute deflector to discharge opening with hex bolts (A) and hex lock nuts (B). Heads of the hex bolts are inside the discharge opening. Hex nuts go on the outside.
3. Tighten all four nuts and bolts securely.

FIGURE 2.

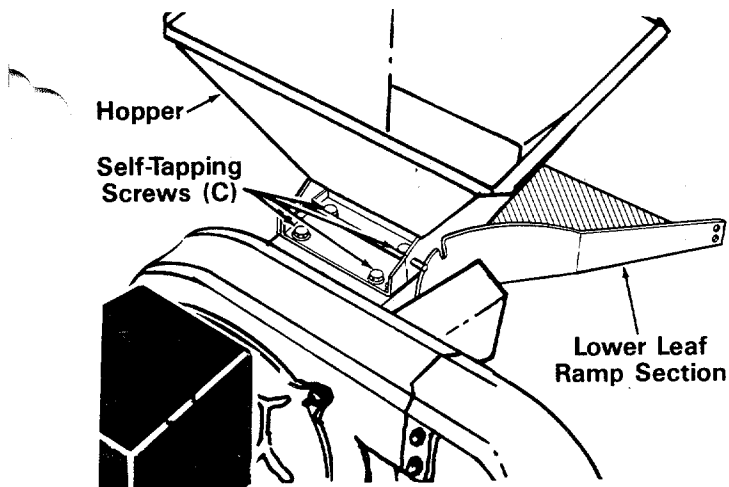

FIGURE 3.

### INSTALLATION OF HOPPER AND UPPER LEAF RAMP

1. The lower leaf ramp section on the shredder is placed in an upright position for shipping purposes. Lower this section.
2. Place the hopper in position on the shredder. See figure 3. Start all four hex washer head self-tapping screws (C), then tighten securely using a 1/2" socket wrench.

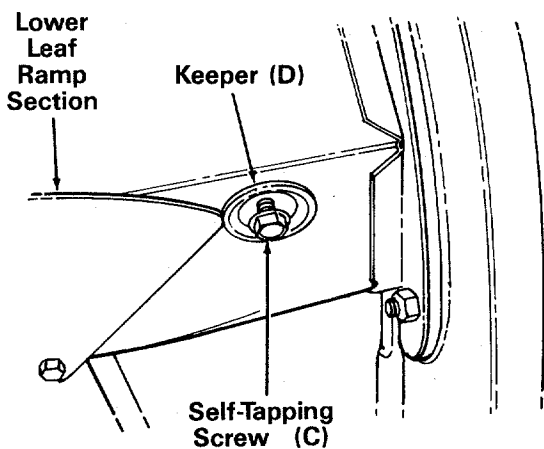

FIGURE 4.

3. Assemble the keepers (D) to the sides of the unit with two hex washer head self-tapping screws (C), using a 1/2" socket wrench. Tighten securely.

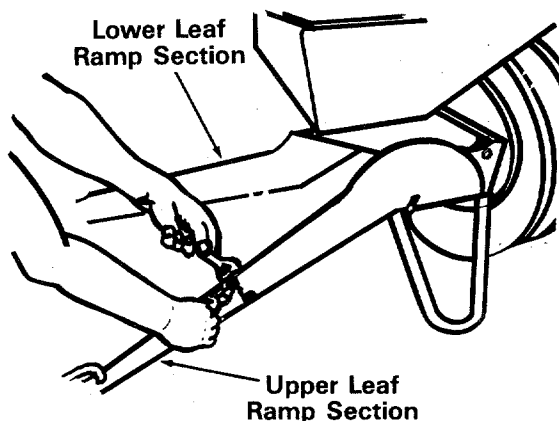

FIGURE 5.

4. Place upper leaf ramp section inside the lower leaf ramp section. Secure with four hex bolts (A) and hex lock nuts (B). Tighten securely. See figure 5.

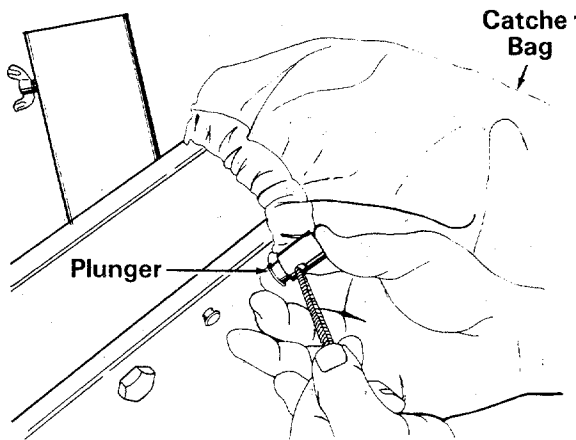

FIGURE 6.

### ATTACHING THE CATCHER BAG

Your unit is equipped with a nylon bag which attaches to the discharge opening. If desired, place the end of the bag over the chute deflector. Depress plunger, pull on the drawstring, and release plunger to lock it in position. See figure 6.

## OPERATION

### GAS AND OIL FILL UP



ENGINE IS SHIPPED WITHOUT OIL. FILL CRANKCASE WITH OIL BEFORE STARTING.

Service engine with gasoline and oil as instructed in the separate engine manual packed with your shredder. Read instructions carefully.

### TO START ENGINE

1. Attach spark plug wire to spark plug.
2. Place choke lever on engine in CHOKE position. See figure 7 or 7A.



A warm engine may not require choking.

3. Place the throttle control lever on engine in FAST position.

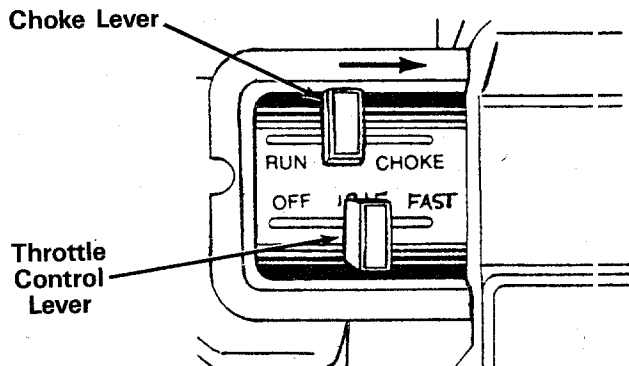

FIGURE 7. - Briggs and Stratton Engine

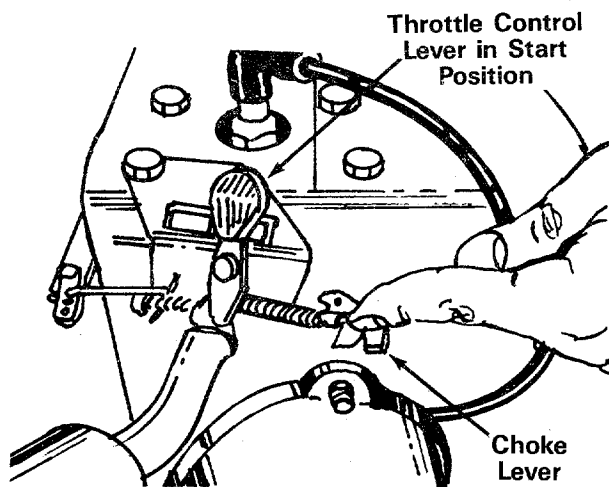

FIGURE 7A. - Tecumseh Engine

4. Grasp starter handle (see figure 8) and pull rope out slowly until engine reaches start of compression cycle (rope will pull slightly harder at this point). Let the rope rewind slowly.



A noise will be heard when finding the start of the compression cycle. This noise is caused by the flails and fingers which are part of the shredding mechanism falling into place, and should be expected.

5. Pull rope with a rapid, continuous, full arm stroke. Keep a firm grip on start handle. Let rope rewind slowly. Do not let starter handle snap back against starter.
6. Repeat preceding instructions 4 and 5 until engine fires.
7. After engine starts, move throttle control lever on engine to slow position for a few minutes warm up. Move choke lever gradually to RUN position. Then move throttle control lever to FAST position for shredding operations.

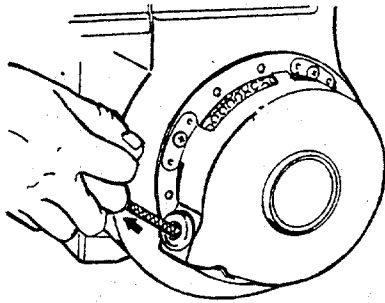

FIGURE 8.

**TO STOP ENGINE**

1. Move throttle control lever to OFF position.
2. Disconnect spark plug wire from spark plug and ground against the engine to prevent accidental starting while equipment is unattended.

**HOW TO USE YOUR SHREDDER**

Your shredder is designed for safe, efficient operation. KEEP HANDS AND FEET AWAY FROM ALL OPENINGS.



Wear the safety glasses provided with your unit while operating the shredder to prevent injury from any chips which may be ejected out of the openings. Make certain chip-it guide is closed when not in use.

Wear gloves when handling material. Feed material into the shredder at a steady rate. It is possible to feed too fast. Experiment with feeding rates to determine what rate provides the best results without stalling the engine or plugging the discharge chute.

The discharge chute will direct the shredded material into a pile, a container or the bag provided with your shredder.



The shredder discharges material with considerable velocity. Keep away from the area around the discharge chute. Always stop the engine and disconnect the spark plug wire when removing or attaching the bag, when changing containers or when removing the shredded material.

If it becomes necessary to push materials into the shredder, use a small diameter stick, NOT YOUR HANDS. The stick should be small enough that it will be ground up if it gets into the impeller assembly.



Do not deposit material larger than 1/2" diameter in the hopper or upper guide extension. Any material heavier than 1/2" should be fed into the chip-it guide.

Leaves and smaller branches can be fed into the hopper with the leaf ramp raised as shown in figures 9 and 10.

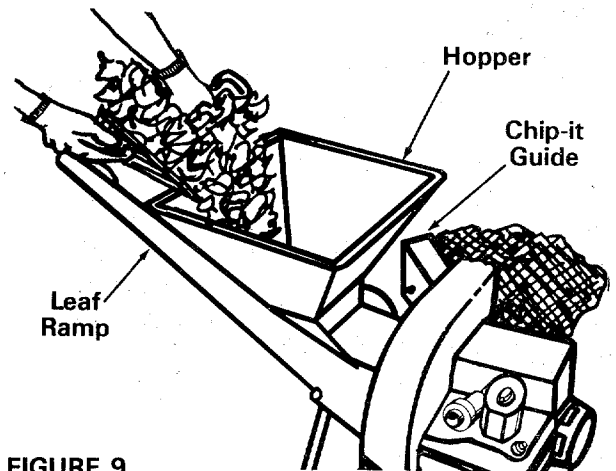

FIGURE 9.

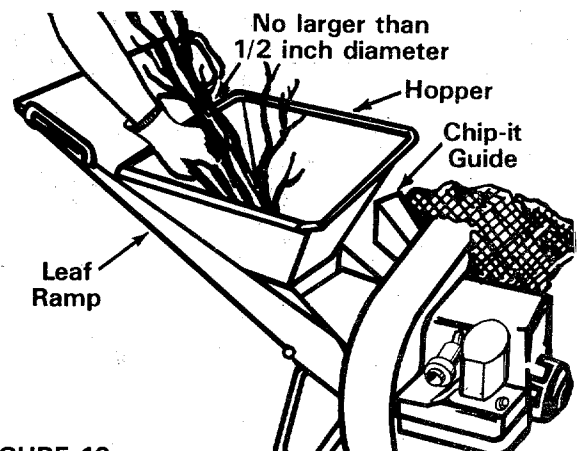

FIGURE 10.

To place in this position, hold the edge of the leaf ramp, pull up on the release bar and gently lower the leaf ramp to the ground. See figures 11 and 12.

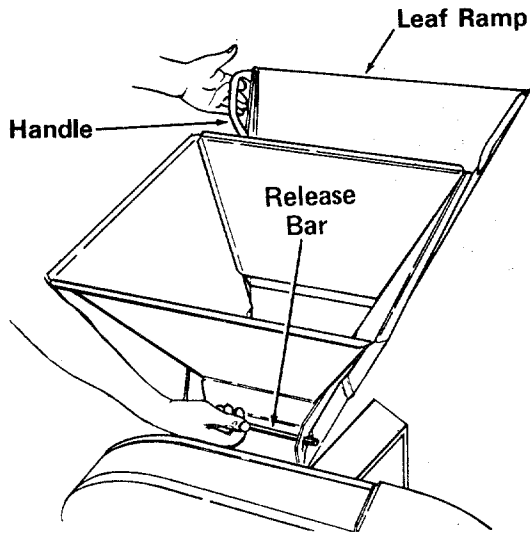

FIGURE 11.

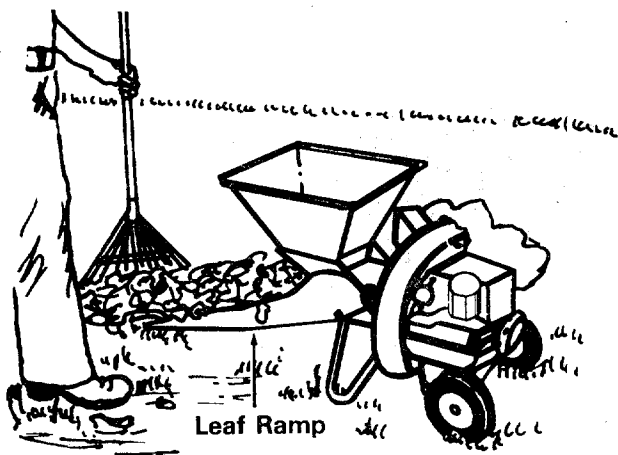

FIGURE 12.

Small branches can also be fed into the leaf ramp See figure 13.

No larger than 1/2 inch diameter

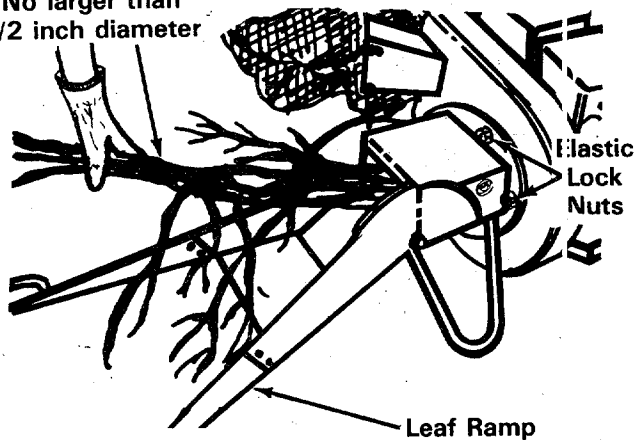

FIGURE 13.

**NOTE**

Bulky material, such as stalks or heavy branches (anything up to 2" diameter), should be fed into the chip-it guide. See figure 14. Do not force or jam material into the chip-it guide. Make certain leaf ramp is raised as shown in figure 14 when using the chip-it guide.



**WARNING**

Make certain chip-it guide door is closed when not in use.

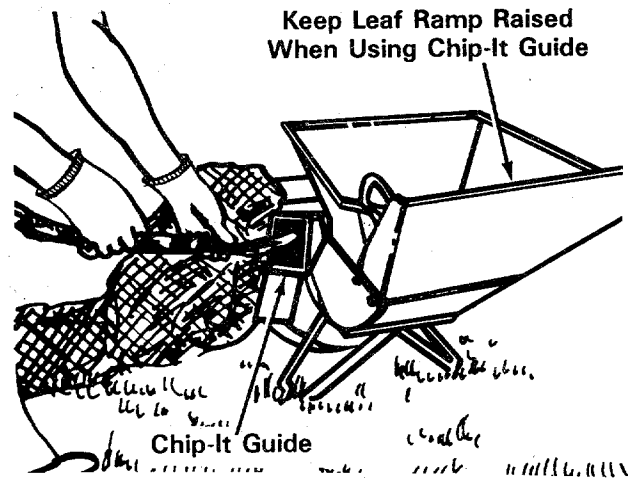

FIGURE 14.

**ADJUSTMENTS**

**CARBURETOR ADJUSTMENT**



**WARNING**

If any adjustments are made to the engine while the engine is running (e.g. carburetor), keep clear of all moving parts. Be careful of heated surfaces and muffler.

Minor carburetor adjustment may be required to compensate for differences in fuel, temperature, altitude or load. If adjustment is needed, refer to the separate engine manual packed with your shredder.

**NOTE**

A DIRTY AIR CLEANER WILL CAUSE ENGINE TO RUN ROUGH. BE CERTAIN AIR CLEANER IS CLEAN AND ATTACHED TO THE CARBURETOR BEFORE ADJUSTING CARBURETOR. DO NOT MAKE UNNECESSARY ADJUSTMENTS. FACTORY SETTINGS ARE SATISFACTORY FOR MOST APPLICATIONS AND CONDITIONS.



# MAINTENANCE



Disconnect spark plug wire and ground it against the engine before performing any repairs or maintenance.

## ENGINE

Refer to the separate engine manual packed with your unit for all engine maintenance procedures. Read instructions carefully.

## AIR CLEANER

The air cleaner prevents damaging dirt, dust, etc., from entering the carburetor and being forced into the engine and is important to engine life and performance.

**Never run your engine without air cleaner completely assembled.**

To service air cleaner; refer to the separate engine manual packed with your unit.

## LUBRICATION

**Wheels** - The wheels require no lubrication.

**Flails and Fingers** - If the unit is disassembled for any reason, lubricate the flails and fingers with a light oil (engine oil may be used).

## CUTTING BLADE

The cutting blade may be removed for grinding or replacement as follows.

1. Lower the upper guide extension.
2. Block up the housing. See figure 15.
3. Remove the four elastic lock nuts from the back of the housing using a 1/2" wrench. Refer to figure 13. Separate the shredder into two halves.
4. Remove the back-up plate. See figure 15.



When reassembling, make certain the opening on the back-up plate is toward the bottom of the unit. The back-up plate may be reversed to provide a new cutting edge.

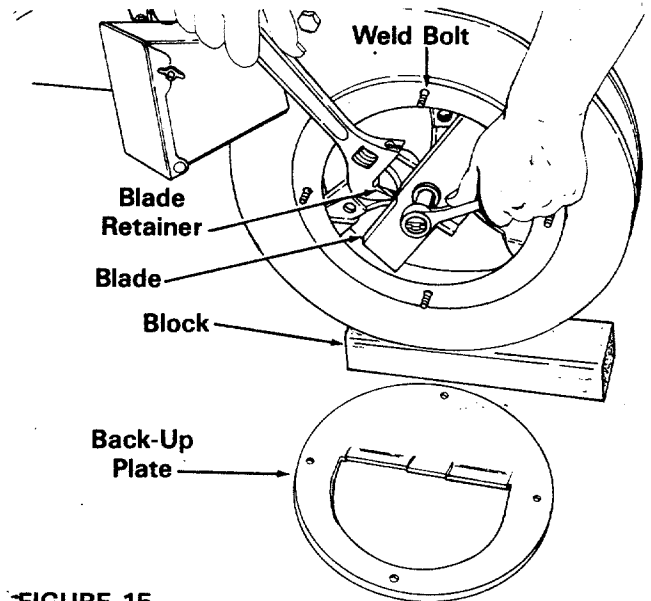

FIGURE 15.

5. Hold the blade retainer on the impeller assembly with an adjustable wrench to keep the blade from turning as shown in figure 15.
6. Remove the blade by removing the center bolt, lock washer and flat washer.



Use caution when removing the blade to avoid contacting the weld bolts protruding from the housing.



The blade is reversible and can be assembled to the crankshaft with either side showing.

When sharpening the blade, follow the original angle of grind as a guide. It is extremely important that each cutting edge receives an equal amount of grinding to prevent an unbalanced blade. An unbalanced blade will cause excessive vibration when rotating at high speeds and may cause damage to the unit.

The blade can be tested by balancing it on a round shaft screwdriver or nail. Remove metal from the heavy side until it balances evenly. See figure 16.

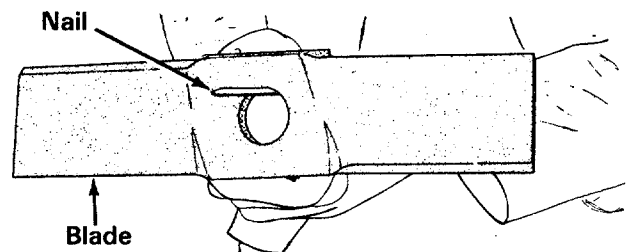

FIGURE 16.

When reassembling the blade, tighten to between 375 and 450 inch pounds, or lacking torque wrench, tighten securely.

### FLAILS AND FINGERS

The flails and fingers may be reversed when they become dull. It is suggested that this procedure be performed by your nearest authorized service dealer.

## OFF-SEASON STORAGE

If the shredder is to be inoperative for a period longer than 30 days, the following precautions are recommended.

1. Working outdoors, drain all fuel from the fuel tank. Run the engine until it stops from lack of fuel.



**DO NOT DRAIN FUEL WHILE SMOKING,  
OR IF NEAR AN OPEN FIRE.**

2. Drain all the oil from the crankcase (this should be done after the engine has been operated and is still warm) and refill crankcase with fresh oil.
3. Protect the inside of the engine for storage as follows.  
Remove spark plug, pour approximately 1/2 ounce (approximately one tablespoon) of engine oil into cylinder and crank slowly to distribute oil. Replace spark plug.
4. Clean the engine and the entire unit thoroughly.



### NOTE

When storing any type of power equipment in an unventilated or metal storage shed, care should be taken to rustproof the equipment. Using a light oil or silicone, coat the equipment, especially all moving parts.

5. Store in a clean, dry area.

## TROUBLE SHOOTING CHART

SYMPTON	POSSIBLE CAUSE(S)	SOLUTION
Engine fails to start	<ol style="list-style-type: none"> <li>1. Check fuel tank for gas.</li> <li>2. Spark plug lead wire disconnected.</li> <li>3. Faulty spark plug.</li> </ol>	<ol style="list-style-type: none"> <li>1. Fill tank if empty.</li> <li>2. Connect lead wire.</li> <li>3. Clean, adjust gap or replace.</li> </ol>
Hard starting or loss of power	<ol style="list-style-type: none"> <li>1. Spark plug wire loose.</li> <li>2. Dirty air cleaner.</li> </ol>	<ol style="list-style-type: none"> <li>1. Connect and tighten spark plug wire.</li> <li>2. Clean air cleaner as described in separate engine manual.</li> </ol>
Engine overheats	<ol style="list-style-type: none"> <li>1. Carburetor not adjusted properly</li> <li>2. Air flow restricted.</li> <li>3. Engine oil level low.</li> </ol>	<ol style="list-style-type: none"> <li>1. Adjust carburetor as instructed in the separate engine manual.</li> <li>2. Remove blower housing and clean as described in the separate engine manual.</li> <li>3. Fill crankcase with the proper oil.</li> </ol>
Material not shredding	Blade and/or flails not sharp.	Sharpen or reverse blade and flails.
Engine bogs down or stalls	<ol style="list-style-type: none"> <li>1. No fuel in fuel tank.</li> <li>2. Feeding material into the machine too quickly.</li> </ol>	<ol style="list-style-type: none"> <li>1. Fill tank if empty.</li> <li>2. Do not force material into the opening. Feed gradually.</li> </ol>

NOTE: For repairs beyond the minor adjustments listed above, please contact your nearest authorized service dealer.

# Model 650

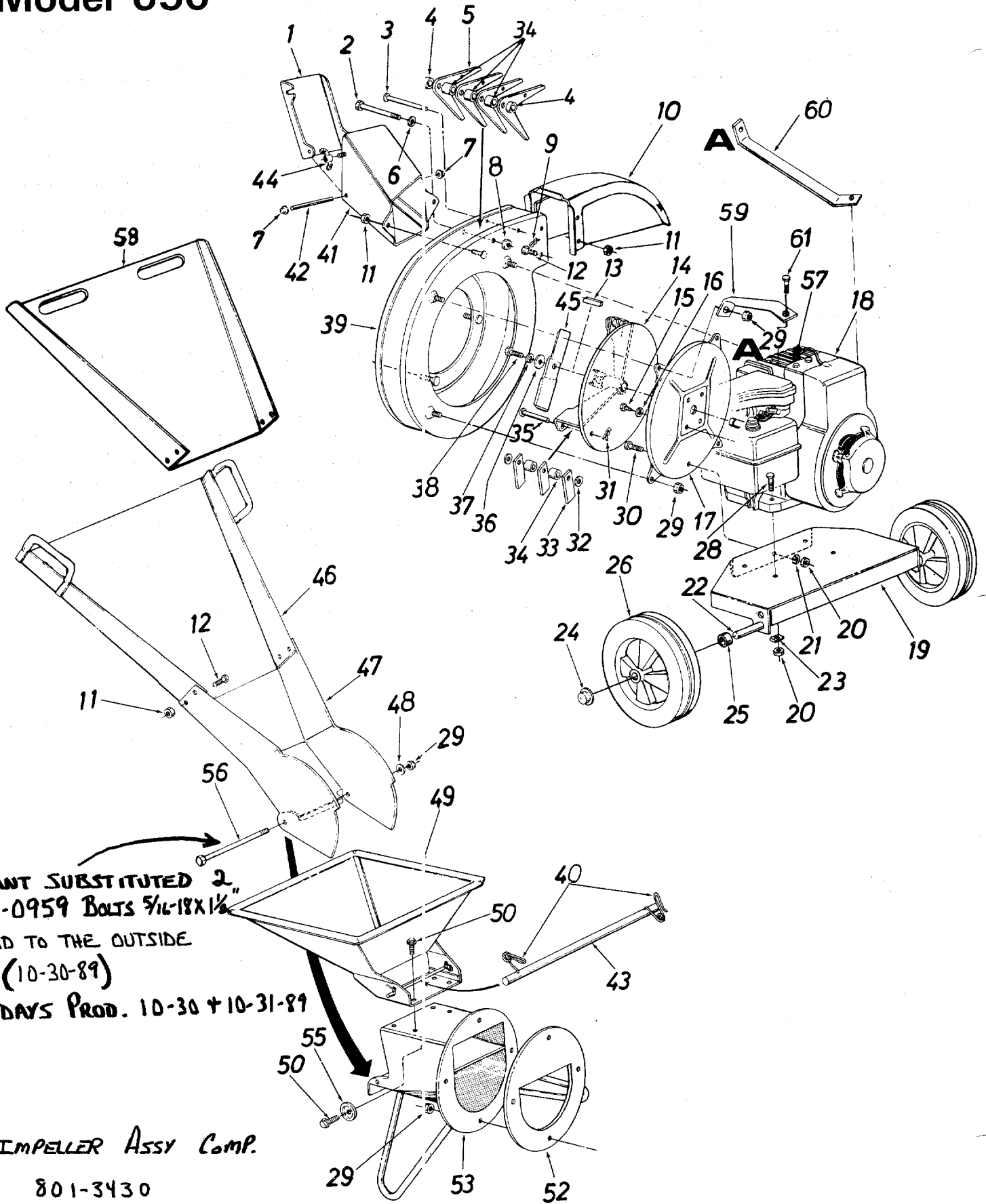

# Model 650

## PART LIST FOR MODEL 650 SHREDDER

Ref. No.	Part No.	Color Code		New Part	Ref. No.	Part No.	Color Code		New Part
1	11476		Door Chip It		33	11459A		Flail	
2	710-0465		Hex Bolt 1/2-20 x 4.50" Lg.*		34	711-0564		Spacer 23/32" Lg.	
3	711-0580		Clevis Pin		35	711-0578		Clevis Pin .50" Dia. x 3.0" Lg.	
4	711-0579		Flail Spacer 7/32" Lg.		36	736-0237		Fl.-Wash. .406" I.D. x 1.25" O.D. Hdn.	
5	11455		Cutting Finger		37	736-0217		L.-Wash. 3/8" I.D. H.D.	
6	736-0921		L.-Wash. 1/2" I.D.*		38	710-0151		Hex Bolt 3/8-24 x 2.0" Lg. H.T.	
7	726-0111		Palnut 3/16" Dia.		39	14575-638		Flail Housing Ass'y.-Comp.	
8	712-0922		Hex Jam Nut 1/2-20 Thd.*		40	732-0546		Torsion Spring .062 Dia. x 1.06 Lg.	
9	714-0507		Cotter Pin 3/32" Dia. x 3/4" Lg.		41	11477		Chip-It Guide Ass'y.	
10	16568		Chute Delfector		42	11478		Hinge Pin	
11	712-0107		L.-Nut 1/4-20 Thd.		43	747-0531		Release Bar	
12	710-0289		Hex Bolt 1/4-20 x .50" Lg.*		44	712-0109		Wing Nut Elastic 1/4-20 Thd.	
13	714-0115		Sq. Key 1/4" x 2.00" Lg.		45	13431		Blade	
14	13430		Impeller Assembly		46	11460-638		Upper Leaf Ramp Section	
15	710-0157		Hex Bolt 5/16-24 x 3/4" Lg.		47	16524-638		Lower Leaf Ramp Section	
16	736-0119		L.-Wash. 5/16" I.D.*		48	736-0264		Fl.-Wash. 5/16" I.D.	
17	14573		Hopper to Engine Mtg. Plate		49	11481A-638		Hopper Assembly	
18	-----		Engine		50	710-0601		Hex Wash. Hd. Self-Tap Scr. 5/16-18 x .75" Lg.	
19	11464A		Engine Mounting Plate		52	11454		Back-Up Plate	
20	712-0123		Hex Nut 5/16-24 Thd.*		53	16522		Inlet Guide Assembly	
21	736-0119		L.-Wash. 5/16" I.D.*		55	11480		Stop Washer	
22	738-0521		Shaft		56	710-0542		Hex Bolt 5/16-28 x 8.38" Lg.	
23	736-0170		Special L.-Wash. 5/16" I.D.		57	735-0639		Spark Plug Boot (Optional)	
24	726-0221		Push Cap		58	11461B		Upper Leaf Ramp Section (Optional)	N
25	711-0494		Spacee		59	781-0420		impeller Hsg. Support Brace -R.H.	N
26	734-1056		Wheel Ass'y.-Comp. (White)		60	781-0421		Impeller Hsg. Support Brace -L.H.	N
27	734-1173		Wheel Ass'y.-Comp. (Silver)		61	---		Part of Engine	
28	710-0624		Hex Bolt 5/16-24 x 1.50" Lg.*		---	764-0199		Bag (Not Shown)	
29	712-0429		Elastic Lock Nut 5/16-18 Thd.		---	723-0400		Safety Glasses (Not Shown)	
30	710-0237		Hex Bolt 5/16-24 x .62" Lg.*						
31	714-0144		Cotter Pin 1/8" Dia. x 1.00" Lg.* (Special)						
32	736-0192		Fl.-Wash. .531" I.D. x .937 O.D. x .09						

\*For Faster service obtain standard nuts, bolts and washers locally. If these items cannot be obtained locally, order part number and size as shown on parts list.

638—Red  
483—Charcoal Gray

When ordering parts if color or finish is important, use color code shown at left. [i.e. (part no.)—638 for Red Finish]

The engine is not under warranty by the shredder manufacturer. If repairs or service is needed on the engine, please contact your nearest authorized engine service outlet. Check the "Yellow Pages" of your telephone book under "Engines—Gasoline."



Specifications subject to change without notice or obligation.



3

3

3

