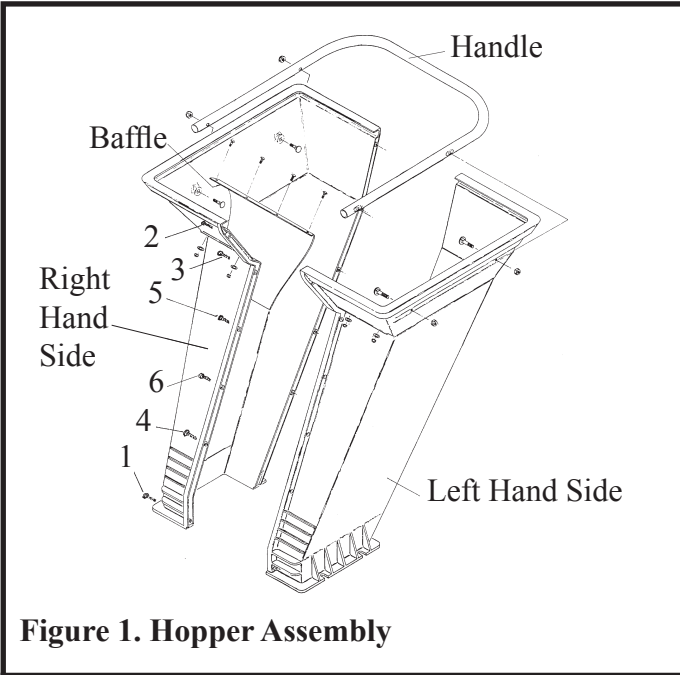


# Owners Manual

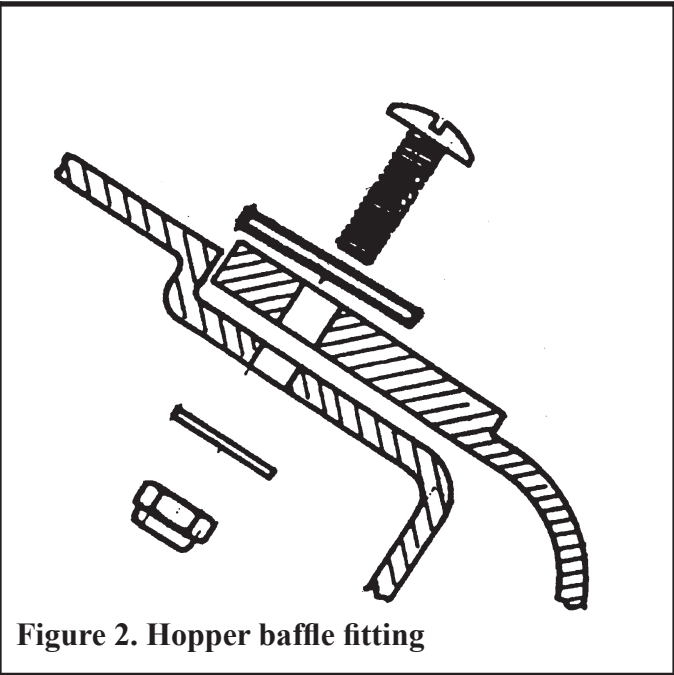
## Chip 'N' Shred™

Model No:            98117 - Petrol  
                             9862 - Petrol  
                             9848 - Petrol  
                             9885 - 240 Volt Electric

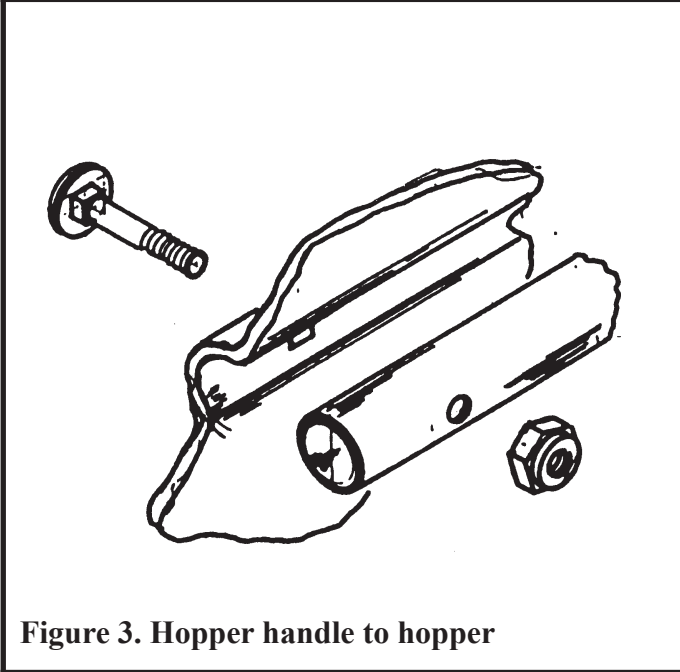




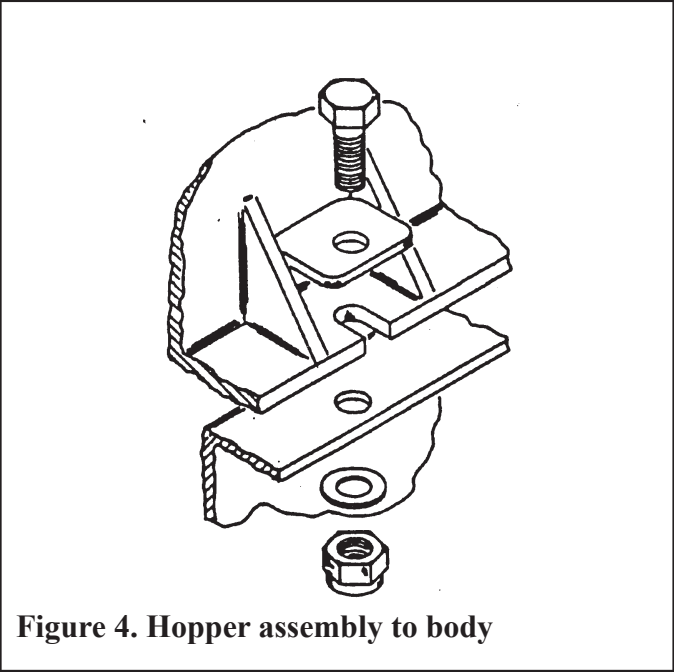
**Figure 1. Hopper Assembly**



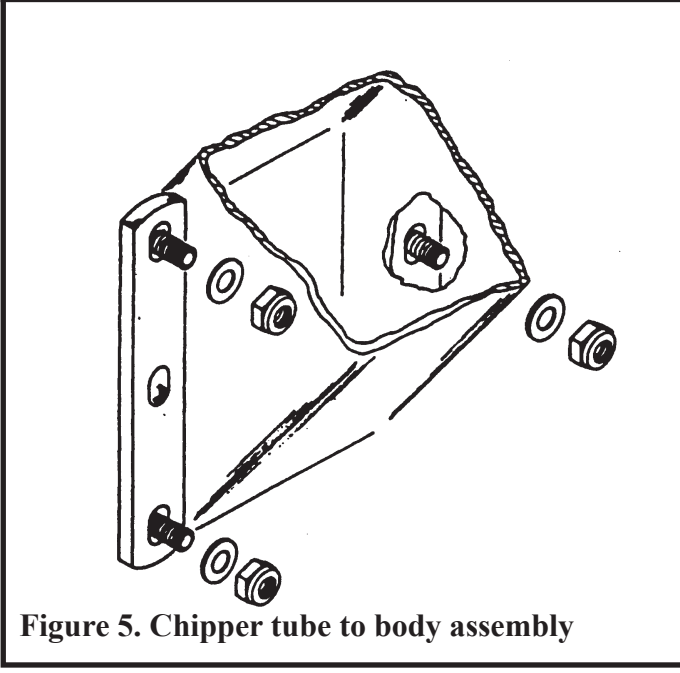
**Figure 2. Hopper baffle fitting**



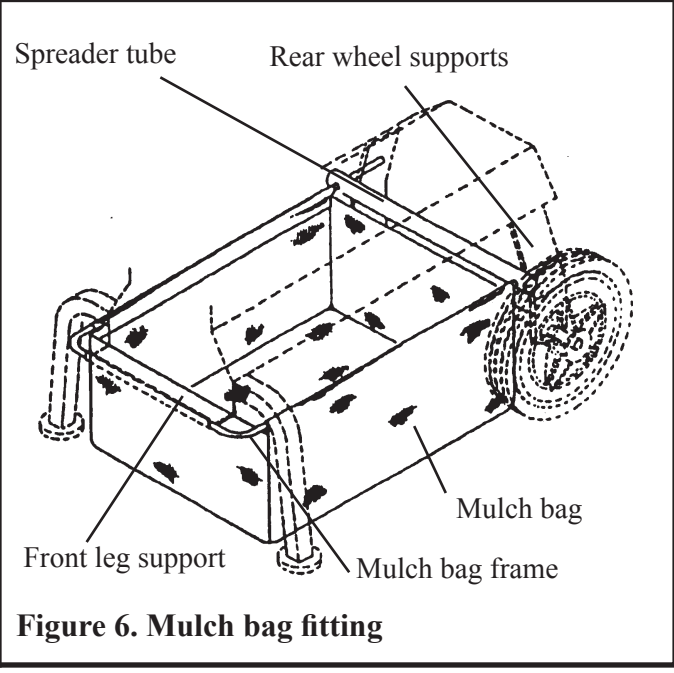
**Figure 3. Hopper handle to hopper**



**Figure 4. Hopper assembly to body**



**Figure 5. Chipper tube to body assembly**



**Figure 6. Mulch bag fitting**

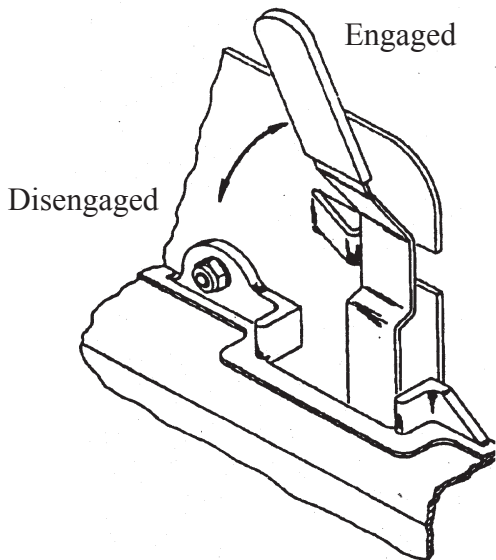


Figure 7. Clutch Lever - Petrol Models

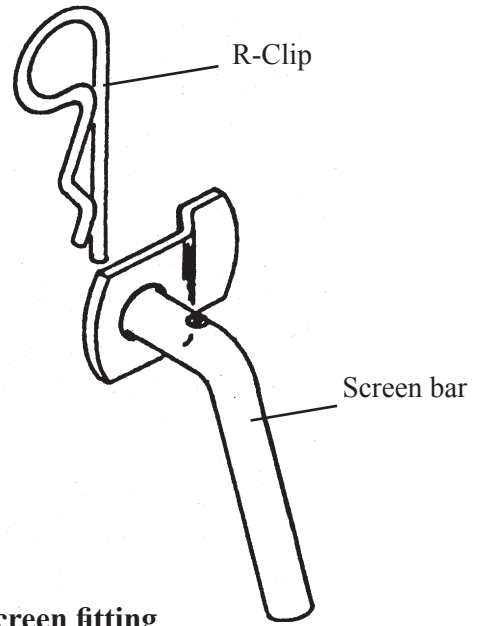


Figure 8. Screen fitting

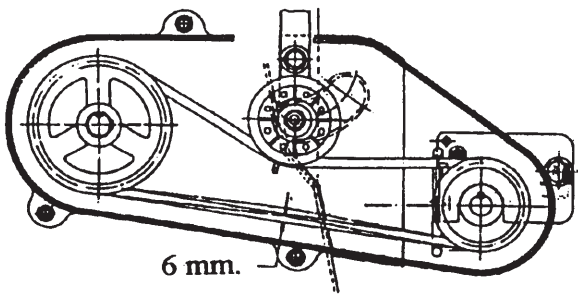


Figure 9. Drive belt adjustment - Petrol Models

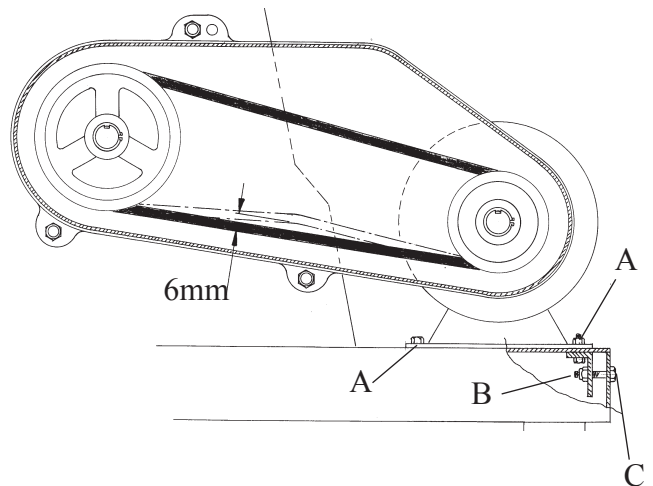


Figure 10. Drive belt Adjustment - Electric Models

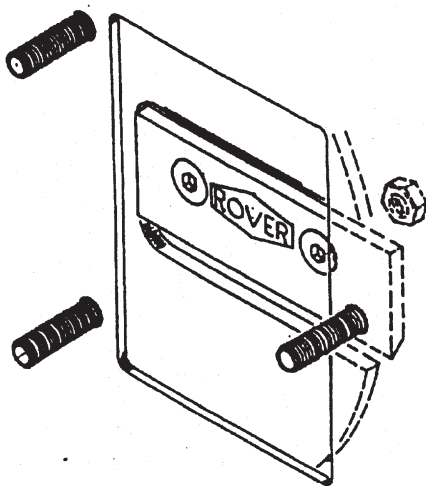


Figure 11. Chipper blade removal and fitting

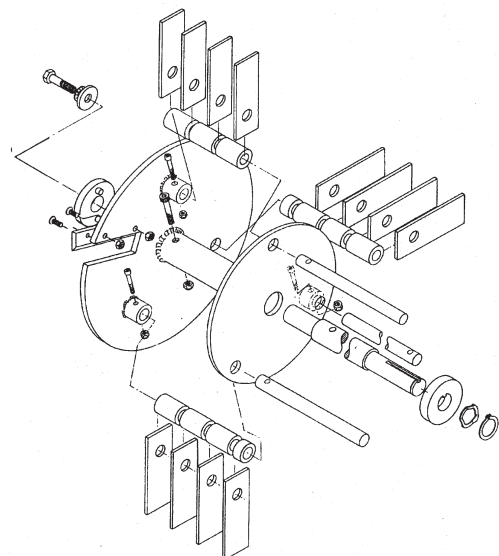


Figure 12. Rotor assembly

**Congratulations on your purchase of a quality Australian made and owned ROVER product.**

This manual covers the operation of the petrol and electric powered Rover Chip ‘N’ Shred™  
Please read and understand this Owners Manual, and the accompanying Engine manufacturers manual for petrol models.

If any point is unclear, contact Rover Mowers Limited or any authorised Rover Mower service dealer.

<b>WARNING</b>
The safety of the user and others involved. Personal injury may result should this information be disregarded

<b>CAUTION</b>
Follow these instructions to avoid machine damage and possible loss of warranty.

**CONTENTS**

Preface..... iii

Safety instructions..... iv

1. Specifications..... 1

2. Setting up..... 1

2.1 Loose parts kit..... 1

2.2 Hopper, handle and baffle assembly ..... 2

2.3 Hopper assembly to body ..... 2

2.4 Chipper tube to body ..... 2

2.5 Mulch bag ..... 2

2.6 Engine lubrication - Petrol Models..... 2

2.7 Fuel - Petrol Models ..... 3

3. Operation ..... 3

3.1 To start the engine - Petrol Models..... 3

3.2 To stop the engine - Petrol Models..... 3

3.3 Rotor engagement - Petrol Models..... 3

3.4 Rotor disengagement - Petrol Models ..... 3

3.5 Operation - Electric Models..... 3

3.6 Shredding Material ..... 3

3.7 Chipper tube feeding..... 3

3.8 Screens..... 4

3.9 Screen removal ..... 4

3.10 Screen fitting..... 4

4. Maintenance..... 4

4.1 Oil Change - Petrol Models ..... 4

4.2 Lubrication points - Petrol Models..... 4

4.3 Drive belt adjustment - Petrol Models..... 4

4.4 Drive belt adjustment - Electric Models..... 4

4.5 Chipper blade removal and fitting ..... 5

4.6 Chipper blade sharpening ..... 5

4.7 Flails ..... 5

4.8 Flail removal..... 5

4.9 Flail fitting ..... 5

4.10 Routine maintenance ..... 5

5. Composting..... 6

5.1 Mulch..... 6

5.2 Compost..... 6

5.3 Humus..... 6

5.4 Mulching the garden..... 6

5.5 Composting..... 6

5.6 Suitable materials for composting ..... 6

5.7 Materials that should never be composted..... 6

**ILLUSTRATIONS**

Figure 1. Hopper assembly ..... i

Figure 2. Hopper baffle fitting ..... i

Figure 3. Hopper handle to hopper ..... i

Figure 4. Hopper assembly to body ..... i

Figure 5. Chipper tube to body assembly ..... i

Figure 6. Mulch bag fitting ..... i

Figure 7. Clutch lever - Petrol Models ..... ii

Figure 8. Screen fitting..... ii

Figure 9. Drive belt adjustment - Petrol Models ..... ii

Figure 10. Drive belt adjustment - Electric Models..... ii

Figure 11. Chipper blade removal and fitting ..... ii

Figure 12. Rotor assembly ..... ii

**Training**

- \* Become familiar with the Owner's Manual before attempting to operate this equipment.
- \* Do not allow children to operate this equipment.
- \* Do not operate this equipment in the vicinity of bystanders.
- \* Carbon dioxide can be extremely dangerous in enclosed areas; do not run the machine in an enclosed area since the exhaust from the engine contains carbon monoxide, which is colourless, odourless, and tasteless.
- \* Do not place hands or any other part of the body or allow clothing inside the feeding chamber, discharge chute, or near any moving part.
- \* Before inspecting or servicing any part of the machine, shut off the power supply, disconnect the power cord or disconnect the spark plug lead from the spark plug, and make sure that all moving parts have come to a complete stop.

**Preparation**

- \* Obtain and wear safety glasses and gloves at all times while operating the machine.
- \* Avoid wearing loose fitting clothing. Operate the machine only on a level surface.
- \* Do not operate the machine on a paved or gravel surface. Thrown objects could cause injury.
- \* Before starting the machine, check that all screws, nuts, bolts, and other fasteners are properly secured. Replace damaged or unreadable warning and operator labels.
- \* Use extra care in handling petrol and other fuels. They are flammable and vapours are explosive.
  - a. Use only an approved container.
  - b. Never remove fuel cap or add fuel with the engine running. Allow engine to cool before refuelling. Do not smoke.
  - c. Never refuel the machine indoors.
  - d. Never store the machine or fuel container inside where there is an open flame, such as a gas water heater.

**Operation**

- \* Before starting the machine, make certain that the cutting chamber is empty.
- \* When feeding shreddable material into the equipment be extremely careful that pieces of metal, rocks, bottles, cans or other foreign objects are not included.

- \* If the cutting mechanism strikes any foreign objects or if the machine should make any unusual noise or vibration, immediately switch off the engine and allow the machine to stop. Disconnect the spark plug wire from the spark plug or remove power cord from power supply and take the following steps.
  - a. Inspect for damage
  - b. Replace or repair any damaged parts.
  - c. Check for and tighten any loose parts.

Do not attempt to repair the machine unless you are competent to do so.

- \* Keep the engine clean of debris and other accumulations to prevent damage to the engine or possible fire.
- \* Do not allow processed material to build up in the discharge area. This may prevent proper discharge and can result in kickback of material through the feed opening.
- \* Keep all guards and deflectors in place and in good working condition.
- \* Always stand clear of the discharge area when operating this machine.
- \* Keep your face and body away from the feed opening.
- \* Do not overreach. Keep proper balance and footing at all times.
- \* Do not tamper with the engine governor settings on petrol engines; the governor controls the maximum safe operating speed and protects the engine and all moving parts from damage caused by over speed. Seek authorised service if a problem exists.
- \* Do not transport this machine while the engine is running.
- \* If the machine becomes clogged, switch-off the engine and disconnect the spark plug lead or remove the power lead from power supply, before cleaning debris away.
- \* Switch-off the unit before attaching or removing the mulch bag.

**Maintenance**

- \* When this equipment is stopped for servicing, inspection, or storage, or to change an accessory, make sure the spark plug lead is disconnected from the spark plug, or the power cord is removed from power supply. Allow the machine to cool before making any inspections, adjustments, etc. Maintain the machine with care and keep it clean.
- \* Store the machine out of the reach of children and where petrol vapours will not reach an open flame or spark. For extended storage periods, run the unit dry of fuel. Always allow the machine to cool before storing.

**General Electrical Safety Rules**

1. Avoid dangerous environments such as damp locations.
2. Do not abuse the power cord. Never pull a machine by the cord or pull the cord to disconnect it from the outlet socket. Keep the cord away from excessive heat, oil, and sharp edges.
3. Disconnect the machine when not in use, before servicing and when changing attachments.
4. Avoid accidental starting. Be sure to switch off before plugging the cord into a power outlet.
5. To prevent electrical shock, use the machine only with an extension cord suitable for outdoor use as recommended by the extension cord manufacturer; the use of suitable extension cords is extremely important for the operator’s personal safety.
6. Never use an indoor type of extension cord: these cords are designed for use with lamps and small appliances and are inadequate for high-powered machines.

7. Make sure the extension cord is in good condition. A cord with cracked or broken insulation is hazardous, particularly in the presence of moisture or combustible material. It is also important that the cord connectors be of rugged construction, in good condition, and securely attached to the outer jacket.
8. If the extension cord is damaged in any manner while operating the machine, immediately switch off the power supply and remove the extension cord from the power outlet.
9. If the supply cord is damaged it must be replaced by a CMG Service Agent or similarly qualified person in order to avoid a hazard.

**Electrical Supply Capacity and Fuses**

1. Use only an electric circuit having adequate capacity.
2. Blowing a fuse or tripping a circuit breaker is a warning that you are overloading your machine or have too many devices in use on that circuit, or both. Determine the cause and correct it. Do not install a higher capacity fuse.

**1. SPECIFICATIONS**

Rover Model No.	9885 (Electric)	9848 (Petrol)	9862 (Petrol)	98117 (Petrol)
Engine Model No.	A09189	93302	127432	G200F
Power Rating	2.2 kW	2.6 kW	4.1 kW	4.1 kW
Fuel Capacity		2.4 litres	4.5 litres	3.6 litres
Oil Capacity		600ml	600ml	600ml
Oil Grade		Refer engine manufacturer's booklet	Refer engine manufacturer's booklet	Refer engine manufacturer's booklet
Voltage	230-240 volts			
Current FL	9.8 amps			
Frequency	50Hz			
Phase	Single			
No. Flails	12	12	12	12
No. Chipper Blades	1	1	1	1
Chipper Opening	71 x 71 mm	71 x 71 mm	71 x 71 mm	71 x 71 mm
Weight (kg)	56	51	56	56

**2. SETTING UP**

**2.1 Loose Parts Kit**

Feed hopper half LH.....	1
Feed hopper half RH.....	1
Hopper baffle.....	1
Hopper handle.....	1
Hopper washers.....	4
Chipper tube assembly.....	1
Manual.....	1
Bar screen assembly.....	1
Screws- 10 x 3/4” pan p/head.....	12
Bolts- 1/4” x 1-1/2” unc. cuphead.....	4

Nyloc nuts- 1/4” unc.....	4
Screws- 3/16” x 5/8” mush.head.....	4
Nyloc nuts- 3/16” unc.....	4
Washer- 3/16” x 1/2” x 20g.flat.....	4
Washer- 3/16” x 3/4” x 16g.flat.....	4
Nyloc nuts- 5/16” unc.....	7
Setscrew- 5/16” x 1” unc. hex.....	7
Washers- 5/16” x 5/8” x 18g. flat.....	7

When disassembling the timber packing, discard the four nuts and retain the bolts and washers for the handle assembly. The four nyloc nuts found in the loose parts list are to be used on the handle bolts.

**2.2 Hopper handle and baffle assembly**

**The feed hopper as supplied with the Chip ‘N’ Shred™ needs to be assembled before use.**

1. Lay the right hand side half of the hopper down on a flat surface with the joint flange pointing up.
2. Position the left hand side half of the hopper on top of the right hand side aligning the joint flange and screw holes. Figure 1.
3. Insert the self tapping screws in the front flanged joint in the sequence shown (1-6) and tighten. Figure 1.
4. Insert the self tapping screws in the rear flanged joint in the same sequence as in the front flange and tighten. Figure 1.
5. Support the hopper in an upright position and fit the hopper baffle inside the hopper by aligning the four holes in the top edge of the baffle with the four matching holes on the ledge in the top of the hopper. Figure 2.
6. Retain the hopper baffle with the four 3/16” x 5/8” mush.head screws with the four large 3/16” Flat washers under their heads and inserted from the inside with the 3/16” small flat washers and 3/16” nyloc nuts on the outside of the hopper. Figure 2.
7. Locate the hopper handle and slide it into the grooves located near the top of the hopper body so that the holes in the handle are in alignment with the holes in the hopper. Figure 3.
8. Retain the hopper handle with the four 1/4” x 1-1/2” unc. cuphead bolts inserted from the inside of the hopper with the four 1/4” unc. nyloc nuts on the outside. Figure 3.

**2.3 Hopper assembly to body**

<b>WARNING</b>
The hopper assembly must be fitted to the Chip ‘N’ Shred™ body before attempting to start or use the Chip ‘N’ Shred™

1. Lift the hopper into position on top of the flange on the Chip ‘N’ Shred™ body with the hopper handle pointing out over the engine.
2. Align the slots in the hopper flange with the holes in the body flanges, and insert four 5/16” x 1” unc bolts with the hopper washers under their heads. Figure 4.
3. Retain with four 5/16” washers and four 5/16” nyloc nuts under the body flange and tighten. Figure 4.

**2.4 Chipper tube to body**

<b>WARNING</b>
The chipper tube assembly must be fitted to the Chip ‘N’ Shred™ body before attempting to start or use the Chip ‘N’ Shred™

1. Remove the rotor shaft cover from the bearing.
2. Slide the chipper tube assembly into the rectangular port on the right hand side of the Chip ‘N’ Shred™ so that the holes in the flanges on the chipper tube align with the studs on the Chip ‘N’ Shred™ body. Figure 5.
3. Retain the chipper tube assembly with three 5/16” unc. nyloc nuts and three 5/16” flat washers.
4. Replace the rotor shaft cover.

**2.5 Mulch bag**

**Assembly**

1. Slide the Mulch bag frame into the pockets along the top edge of each side of the mulch bag.
2. Slide the spreader tube onto the ends of the bag frame till the hole in the frame are within the tube and retain with the two ‘R’ clips inserted into the holes in the frame.

**Fitting**

3. Slide the mulch bag under the Chip ‘N’ Shred™ from the front between the support legs and rest the mulch bag frame on the rear wheel supports. Lift the front bar of the mulch bag frame over the front lip on the front legs support. Figure 6.

**2.6 Engine lubrication - Petrol Models**

The engine oil level must be checked before attempting to start the engine. **Refer to the engine manufacturer’s instructions.**

<b>CAUTION</b>
Avoid premature engine failure by using a clean funnel and cleaning away any possible contaminants.

## 2.7 Fuel




1. Position the Chip 'N' Shred™ on a level surface in a well ventilated area. Clean around the fuel tank cap.
2. Remove the fuel tank cap.

3. Using a clean funnel fill the fuel tank with clean fresh unleaded petrol.
4. Replace the fuel tank cap.
5. Wipe up any spilt petrol.

## 3. OPERATION

### 3.1 To start the engine - Petrol Models

Refer to the engine manufacturers instructions

1. Move the clutch lever to the disengaged position.
2. Move the choke lever to the choke position. 
3. Move the throttle lever to the fast  position.
4. Move the fuel shutoff valve to the **on** position (if fitted).
5. Move the Stop Control switch to the **on** position (if fitted).
6. Grasp the starter cord and pull.
7. When the engine starts, move the choke lever to the run position and the throttle lever to the slow position. 


### 3.2 To stop the engine - Petrol Models

Refer to the engine manufacturers instructions


<b>WARNING</b>
Blades continue to free wheel after engine has been switched off

1. Move the throttle lever to the off position. O
2. Move the fuel shutoff valve to the **off** position (if fitted).
3. Move the stop control switch to the **off** position (if fitted).
4. Move the clutch lever to the **disengaged** position if engaged.

### 3.3 Rotor engagement - Petrol Models

1. Start the engine as per the section 3.1.
2. Move the throttle control to the fast position. 
3. Slowly move the clutch lever on the left hand side of the Chip 'N' Shred™ to the **engaged** position. Figure 7.

### 3.4 Rotor disengagement - Petrol Models

1. Move the rotor clutch lever to the disengaged position. 'O' Figure 7.
2. Move the throttle control to the slow  or off 'O' position as required.

### 3.5 Operation - Electric Models

1. Connect the Chip 'N' Shred™ to a suitable power supply with a 15amp rated power cord fitted with 10 amp fittings no longer than 20 meters long. Longer cords will result in voltage drop and possible premature overload drop out and or possible motor damage.
2. To start the Chip 'N' Shred™ move the motor switch to the 'On' position 'I'.

3. To stop the Chip 'N' Shred™ move the motor switch to the 'Off' position 'O'.
4. If the overload switch activates during operation wait 60 seconds, reset the overload and switch the unit back on. This will allow the electric motor time to cool and the overload switch to reset.
5. If after waiting 60 seconds the Chip 'N' Shred™ fails to restart the following procedure should be followed.
  - a. Switch the machine off and disconnect the power supply.
  - b. Check for blockages and that the rotor is free to rotate. If the rotor is jammed remove the screens to clear blockage. Refer to section 3.9.
  - c. Connect to the power supply and switch on the Chip 'N' Shred™
  - d. If the Chip 'N' Shred™ will not start check the fuse or circuit breaker on the electrical circuit being used and rectify if necessary.
  - e. If the Chip 'N' Shred™ will not start and the electrical circuit is found to be operational, contact your local authorised Rover service dealer.

### 3.6 Shredding material

1. Start the Chip 'N' Shred™ engine as per section 3.1 for petrol models or section 3.5 for electric models.

<b>WARNING</b>
Operators should always wear safety glasses, hearing protection and gloves while operating the Chip 'N' Shred™

2. Engage the rotor clutch as per section 3.3. Petrol Models only.
3. Feed branches with foliage first into hopper so as to control the rate of feed. Maximum branch size in shredder hopper is approximately 20mm diameter.
4. When feeding vines or long stringy types of material into the Chip 'N' Shred™, cut them first into lengths of no more than 600mm long. Be careful not to wrap materials around hands when feeding.
5. Do not feed at a faster rate than the Chip 'N' Shred™ can shred and discharge material, as you may stall the rotor and overload the engine and or damage the drive belt.

### 3.7 Chipper tube feeding

Feed larger branches, up to approximately 70mm diameter, into the chipper tube. Control the rate of feed by pulling back on the branch so as not to block the unit and cause it to stall.



### 3.8 Screens

Two screens are supplied with the Chip 'N' Shred™, the standard screen consisting of numerous holes in a curved plate and a bar screen consisting of widely spaced bars between two side plates.

The size of the mulch produced by either shredding or chipping is dependent on the screen fitted to the Chip 'N' Shred™

The screen to be used depends on the type of material to be processed. The standard screen suits most types of material found in the garden. If moist, pulpy or soggy types of material are to be processed the bar screen should be fitted to avoid blockages.

### 3.9 Screen removal

1. Switch engine off.
2. Remove the spark plug lead from the spark plug or disconnect the power cord from the power supply.
3. When the rotor has come to a stop remove the R-clips from the screen bars and remove the screen bars, the screen should then drop out through the discharge chute. Figure 8.

### 4.1 Oil Change Petrol Models

Refer to the manufacturer's instructions.

1. Position the Chip 'N' Shred™ on a level surface in a well ventilated area.
2. Start and run the engine for 5 minutes to warm up the engine oil.
3. Place a container under the oil drain plug.
4. Using a 10mm open end spanner remove the engine drain plug and tilt the Chip 'N' Shred™ to allow the engine oil to drain completely.
5. Refit the engine drain plug tightly and clean up any spilt oil.
6. Fill the engine crankcase with oil. Refer to section 2.6 Engine Lubrication.

### 4.2 Lubrication Points Petrol Models

Using 10w -30 or S.A.E. 30 oil

1. Clutch lever point.
2. Throttle control.

### 4.3 Drive belt adjustment - Petrol Models

1. Stop the Chip 'N' Shred™ and remove the spark plug lead from the spark plug.
2. Remove the drive belt guard.
3. Move the clutch lever to the engaged position.
4. Loosen the four engine mount bolts.
5. Slide the engine away from the Chip 'N' Shred™ body to tighten the drive belt. The drive belt should deflect

### 3.10 Screen fitting

1. Switch the engine off and remove the spark plug lead from the spark plug or disconnect the power cord from the power supply.
2. Choose the correct screen for the material to be processed (refer to section 3.8).
3. Lift and position the screen in the Chip 'N' Shred™ by aligning the holes in the screen and the Chip 'N' Shred™ body. Insert the screen rod closest to the engine first and secure with the R-clip retainer. Figure 8.

**Note: The standard screen can be fitted in the Chip 'N' Shred™ in either direction. The Bar Screen will only fit with the bars pointing away from the engine.**

4. Lift the front of the screen and insert the screen rod through the Chip 'N' Shred™ side plate, retaining with the R-clip.

#### CAUTION

Do not tip petrol models over when full of Petrol and Oil.

## 4. MAINTENANCE

about 6mm when hand pressure is applied, between the engine pulley and the rotor shaft pulley. Figure 9.

6. Tighten the engine mount bolts.
7. Replace the drive belt guard aligning the 'E' hole with retaining stud.
8. Move the clutch engagement lever to the disengaged position and replace the spark plug lead.

#### CAUTION

Do not over tighten drive belt.

### 4.4 Drive Belt adjustment - Electric Models

1. Stop the Chip 'N' Shred™ and disconnect from the power supply.
2. Remove the drive belt guard
3. Loosen the four engine mount bolts 'A' figure 10.
4. Tension the drive belt to give a 6mm deflection when hand pressure is applied, by holding the nut 'B' with a 9/16" A/F spanner and rotating the bolt 'C' clockwise.
5. Tighten the four engine mount bolts.
6. Replace the drive belt guard aligning the 'E' hole with retaining stud.

#### WARNING

The chipper blade is extremely sharp and caution must be used when handling or working with it.

#### 4.5 Chipper blade removal and fitting

##### Chipper blade removal

1. Stop the Chip 'N' Shred™ and remove the spark plug lead from the spark plug, or remove the power cord from the power supply.
2. Remove the three retaining nyloc nuts and washers from the chipper tube and lift off.
3. Remove the hopper assembly fasteners and lift the hopper assembly off the Chip 'N' Shred™ body.
4. Rotate the rotor to expose the chipper blade in the chipper tube port.
5. Using a 1/2" AF ring spanner and a Allen key remove the chipper blade fasteners and remove the chipper blade. Figure 11.

##### Chipper blade fitting

1. Clean the surface of the rotor plate where the chipper blade is attached.
2. Using new 5/16" Nyloc nuts fit the chipper blade to the rotor plate and tighten the nyloc nuts to 19 Nm.
3. Fit the hopper assembly to the Chip 'N' Shred™ body. Refer to section 2.3.
4. Fit the chipper tube to Chip 'N' Shred™ body. Refer section 2.4.
5. Move the clutch engagement lever to the disengaged position and replace the spark plug lead.

#### 4.6 Chipper blade sharpening

To maintain optimum performance from the chipper the blade should be kept sharp. The chipper blade can be ground back a total of 3mm before replacement of the chipper blade is necessary.

1. Remove the chipper blade from the Chip 'N' Shred™ Refer to section 4.5.
2. Maintain the same angle on the blade cutting edge when grinding.
3. Remove any feathers that form by lightly honing the chipper blade on an oil stone.
4. Refit to the Chip 'N' Shred™. Refer to section 4.5.

#### 4.7 Flails

The Chip 'N' Shred™ is fitted with 12 individual flail blades. The relative position of the flails on each bar and to those on other bars is important. If the flail bar is to be removed for any reason the flails must be reassembled in the same position as before disassembly. Figure 12.

#### 4.8 Flail removal

1. Remove the hopper assembly.
2. Remove the belt guard.
3. Remove the chipper tube assembly.
4. Rotate the rotor assembly until the flail bar to be removed is opposite the pilot hole in the left hand side of the Chip 'N' Shred™ body.
5. Remove the flail bar retaining nut and bolt from the shaft.
6. Using a drift inserted through the pilot hole in the chipper shredder side plate, drive out the flail bar through the chipper tube port.

#### 4.9 Flail fitting

1. Determine which flail bar is to be fitted from (Figure 12), and layout next to the Chip 'N' Shred™ the flail blades and spacers.
2. Insert the flail bar through the chipper tube port into the rotor plate.
3. As the flail bar is being pushed into position, place the flail blades and spacers on the flail bar as indicated in figure 12.
4. Replace the flail bar retaining bolt and nut.
5. Fit the chipper tube assembly. Refer section 2.4.
6. Fit the drive belt guard aligning the retainings stud in the correct hole for Petrol and Electric models.
7. Fit the hopper assembly. Refer section 2.3.
8. Fit the spark plug lead to the spark plug - Petrol Models.

#### 4.10 Routine maintenance

After use, always clean down the outside of the Chip 'N' Shred™ to remove any build-up of material. Visually inspect all safety labels and replace any that have become damaged or illegible during operation of the Chip 'N' Shred™

#### WARNING

Do not hose down the motor or switch on electric models

The inside of the Chip 'N' Shred™ may be hosed out to clean away any build up of mulched material. After hosing out the inside of the Chip 'N' Shred™ spray the rotor assembly, flails and chipper blade with a suitable water dispersant agent (WD 40).

### 5.1 Mulch

Mulch is a mixture of broken down vegetable and organic materials which is used in the creation of compost or used as a covering in a garden bed.

### 5.2 Compost

Compost is a mixture of organic materials, mulch, loam soils, or other medium with added organic matter used to enrich garden beds to promote plant growth.

### 5.3 Humus

Humus is the organic constituents of soils formed by the decomposition of vegetable and organic materials. The Rover Chip 'N' Shred™ helps in the production of Mulch by shredding vegetable and organic materials into small pieces to make mulch that may be either spread throughout the garden bed as a thick layer or can be used to produce a rich compost.

### 5.4 Mulching the Garden

The spreading of a thick layer of mulch throughout the garden bed of between 50 and 150mm thick has many benefits for the garden:

- \* Protects the root system of the plants.
- \* Retains moisture in the soils.
- \* Retards the growth of weeds which can be harmful to plants.
- \* Slowly releases nutrients into the soil to enhance plant growth.
- \* Eliminates the need to use dangerous chemicals and fertilizers and therefore leads to be a healthier environment.
- \* Eliminates the need to use land fill areas to dispose of unwanted garden rubbish. Some councils are now charging for the disposal of garden waste at local land fill areas.

### 5.5 Composting

With the mulch produced from the garden and vegetable waste these can be used to produce a nutrient rich compost. Compost can be produced in several ways from the mulch produced:

#### Compost Heap

A compost heap can be laid out under a tree or in a corner of the garden. Simply spread out a layer of mulch approximately 1200mm x 600mm. This can be then be built up in thin layers of soil and mulch to a height of

600mm. The compost heap should be covered to keep it from becoming water logged or drying out completely. To aid in the decomposition of the mulch, the compost heap should be turned over regularly.

#### Compost Bin

These either take the form of a drum mounted on a frame, or a simple drum standing on end with a removable lid. These types of units are used in a similar manner to the compost heap where mulch, soil and other organic materials are loaded into the drum for the production of compost. The drum mounted on the frame can be easily rotated to aerate the compost during decomposition of the organic materials.

### 5.6 Suitable materials for composting

- \* Vegetable and fruit waste from the kitchen.
- \* Dead plants and flowers Plant cuttings and prunes.
- \* Green branches from small trees Sawdust and pulverised wood shavings.
- \* Mulched material from the Rover Chip 'N' Shred™.
- \* Cow, horse and chicken manure.

### 5.7 Materials that should NEVER be composted.

- \* Metal objects.
- \* Glass and ceramics Plastics.
- \* Chemicals and Solvents.
- \* Dog and cat droppings.
- \* Meat scraps and bones.

# Warranty Conditions

## Australia & New Zealand Only

Rover Mowers Limited warrant that this machine is free from defects in material and workmanship. This warranty is limited to making good or replacing any part which appears upon inspection by the manufacturer or his agent to be defective in material or workmanship.

The petrol engine used to power this machine is warranted by the manufacturer whose warranty statement has been included with the machine. As the warranty for the engine may differ from the warranty for the other components, you are advised to read the engine manufacturer's warranty carefully.

For other items this warranty shall apply for a period of 12 months from date of purchase except for products used commercially where the warranty is limited to 90 days.

This warranty does not obligate the manufacturer, his agents or dealers to bear the transport costs incurred in the repair or replacement of any defective part.

Online warranty registration - [www.rovermowers.com.au](http://www.rovermowers.com.au)

This warranty excludes fair wear and tear, or any damage caused by misuse or abuse. Parts such as blades, blade bolts, v-belts and spark plugs, which can be subjected to use beyond their normal intended working capacity are also excluded.

This warranty is void if parts other than genuine have been used or if repairs or alterations have been made without the manufacturer's written authority.

The above warranty does not exclude any condition or warranty implied by the Trade Practices Act 1974 or any other relevant legislation which implies any condition which cannot be excluded.

**REMEMBER:  
PROOF OF PURCHASE IS THE  
RESPONSIBILITY OF THE OWNER AND IS  
NECESSARY PRIOR TO WARRANTY WORK  
BEING UNDERTAKEN. REPAIRS MUST BE  
CARRIED OUT BY AN AUTHORISED DEALER  
AND GENUINE SPARE PARTS MUST BE USED  
OR YOUR WARRANTY WILL BE VOID.**

## For your record:

Dealer's name: .....

Dealer's address: .....

Dealer's phone no: .....

Product Model no: .....

Product Serial no: .....

Date of Purchase: .....

Rover Mowers Limited reserves the right to make changes of and add improvements upon its product at any time without notice or obligation. The Company also reserves the right to discontinue manufacture of any product at its discretion at any time.



Quality  
Endorsed  
Company

ISO 9001 Lic 10168  
Standards Australia

**ROVER**  
Mowers Limited

A.B.N. 11 000 257 303

Rover Mowers Limited, PO. Box 1235, Eagle Farm. Qld. Australia. 4009  
Phone: 07 3213 0233



RECYCLED PAPER



GWAIL GROUP

PRINTED IN AUSTRALIA

© Copyright  
10 - 2008

04009134  
Rev. F