

OPERATOR'S MANUAL

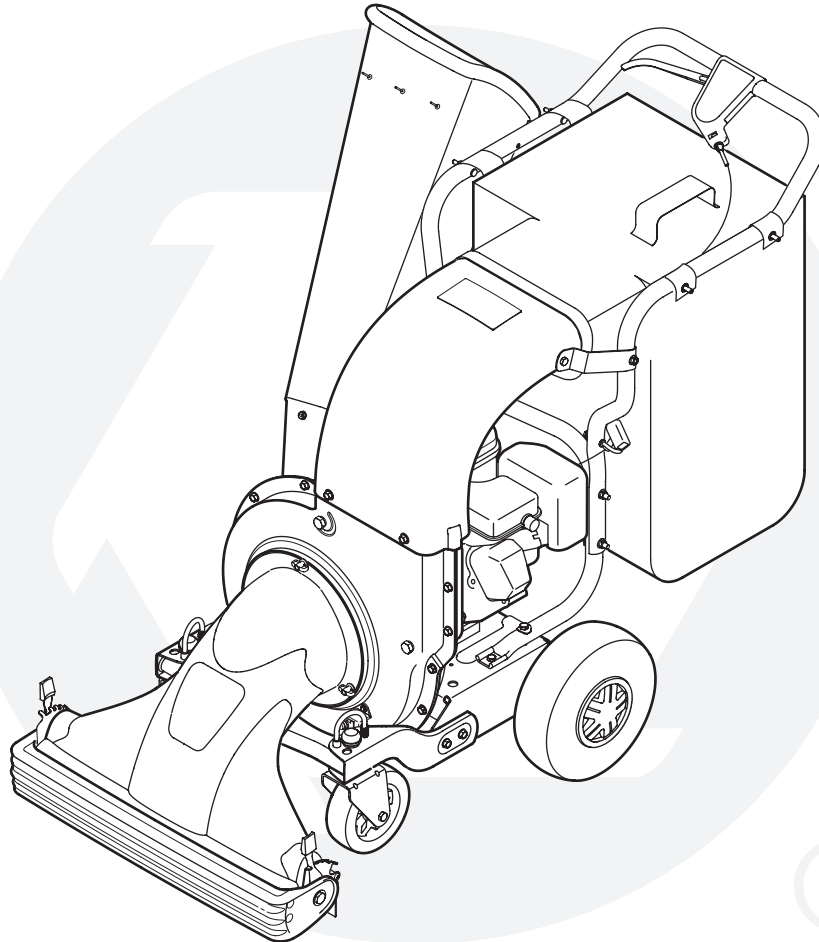

Chipper Shredder Vacuum - Model 204

IMPORTANT

READ SAFETY RULES AND INSTRUCTIONS CAREFULLY BEFORE OPERATION

Warning: This unit is equipped with an internal combustion engine and should not be used on or near any unimproved forest-covered, brush-covered or grass-covered land unless the engine's exhaust system is equipped with a spark arrester meeting applicable local or state laws (if any). If a spark arrester is used, it should be maintained in effective working order by the operator. In the State of California the above is required by law (Section 4442 of the California Public Resources Code). Other states may have similar laws. Federal laws apply on federal lands. A spark arrester for the muffler is available through your nearest engine authorized service dealer or contact the service department, P.O. Box 361131 Cleveland, Ohio 44136-0019.

This Operator's Manual is an important part of your new chipper shredder vacuum. It will help you assemble, prepare and maintain the unit for best performance. Please read and understand what it says.

Table of Contents

Customer Support.....	2	Troubleshooting.....	12
Safe Operation Practices	4	Safety Labels	13
Setting Up Your Chipper Shredder Vacuum	6	Parts List	14
Operating Your Chipper Shredder Vacuum	8	Warranty	Back Page
Maintaining Your Chipper Shredder Vacuum .	10		

Finding and Recording Model Number

BEFORE YOU START ASSEMBLING
YOUR NEW EQUIPMENT,

please locate the model plate on the equipment and copy the information to the sample model plate provided to the right. You can locate the model plate by standing behind the unit and looking down at the frame below the engine. This information will be necessary to use the manufacturer's web site and/or obtain assistance from the Customer Support Department or an authorized service dealer.

 **TROY-BILT**[®]
www.troybilt.com

TROY-BILT LLC
P. O. BOX 361131
CLEVELAND, OH 44136
330-558-7220
800-828-5500

Customer Support

Please do *NOT* return the unit to the retailer from which it was purchased, without first contacting Customer Support.

If you have difficulty assembling this product or have any questions regarding the controls, operation, or maintenance of this unit, you can seek help from the experts. Choose from the options below:

1. Visit **troybilt.com**. Click on the Support tab.
2. Phone a **Customer Support Representative** at 1 (800) 828-5500.
3. The **engine manufacturer** is responsible for all engine-related issues with regards to performance, power-rating, specifications, warranty and service. Please refer to the engine manufacturer's Owner's/Operator's Manual, packed separately with your unit, for more information.

NOTES

Use this page to make notes and write down important information.

2

Safe Operation Practices



WARNING

This symbol points out important safety instructions which, if not followed, could endanger the personal safety and/or property of yourself and others. Read and follow all instructions in this manual before attempting to operate this machine. Failure to comply with these instructions may result in personal injury. When you see this symbol.

HEED ITS WARNING!

Your Responsibility

Restrict the use of this power machine to persons who read, understand and follow the warnings and instructions in this manual and on the machine.



WARNING: Engine Exhaust, some of its constituents, and certain vehicle components contain or emit chemicals known to State of California to cause cancer and birth defects or other reproductive harm.

DANGER: This machine was built to be operated according to the rules for safe operation in this manual. As with any type of power equipment, carelessness or error on the part of the operator can result in serious injury. This machine is capable of amputating hands and feet and throwing objects. Failure to observe the following safety instructions could result in serious injury or death.

Training

1. Read, understand, and follow all instructions on the machine and in the manual(s) before attempting to assemble and operate. Keep this manual in a safe place for future and regular reference and for ordering replacement parts.
2. Be familiar with all controls and their proper operation. Know how to stop the machine and disengage them quickly.
3. Never allow children under 16 years old to operate this machine. Children 16 years old and over should read and understand the operation instructions and safety rules in this manual and should be trained and supervised by a parent.
4. Never allow adults to operate this machine without proper instruction.
5. Keep bystanders, helpers, pets, and children at least 75 feet from the machine while it is in operation. Stop machine if anyone enters the area.
6. Never run an engine indoors or in a poorly ventilated area. Engine exhaust contains carbon monoxide, an odorless and deadly gas.
7. Do not put hands and feet near rotating parts or in the feeding chambers and discharge opening. Contact with the rotating impeller can amputate fingers, hands, and feet.
8. Never attempt to unclog either the feed intake or discharge opening, remove or empty vacuum bag, or inspect and repair the machine while the engine is running. Shut the engine off and wait until all moving parts have come to a complete stop. Disconnect the spark plug wire and ground it against the engine.

Preparation

1. Thoroughly inspect the area where the equipment is to be used. Remove all rocks, bottles, cans, or other foreign objects which could be picked up or thrown and cause personal injury or damage to the machine.
2. Always wear safety glasses or safety goggles during operation or while performing an adjustment or repair, to protect eyes. Thrown objects which ricochet can cause serious injury to the eyes.
3. Wear sturdy, rough-soled work shoes and close-fitting slacks and shirts. Loose fitting clothes or jewelry can be caught in movable parts. Never operate this machine in bare feet or sandals. Wear leather work gloves when feeding material in the chipper chute.
4. Before starting, check all bolts and screws for proper tightness to be sure the machine is in safe working condition. Also, visually inspect machine for any damage at frequent intervals.
5. Maintain or replace safety and instructions labels, as necessary.
6. To avoid personal injury or property damage use extreme care in handling gasoline. Gasoline is extremely flammable and the vapors are explosive. Serious personal injury can occur when gasoline is spilled on yourself or your clothes which can ignite. Wash your skin and change clothes immediately.
 - a. Use only an approved gasoline container.
 - b. Extinguish all cigarettes, cigars, pipes, and other sources of ignition.
 - c. Never fuel machine indoors.
 - d. Never remove gas cap or add fuel while the engine is hot or running.
 - e. Allow engine to cool at least two minutes before refueling.
 - f. Never over fill fuel tank. Fill tank to no more than 1/2 inch below bottom of filler neck to provide space for fuel expansion.
 - g. Replace gasoline cap and tighten securely.
 - h. If gasoline is spilled, wipe it off the engine and equipment. Move machine to another area. Wait 5 minutes before starting the engine.
 - i. Never store the machine or fuel container inside where there is an open flame, spark, or pilot light (e.g. furnace, water heater, space heater, clothes dryer, etc.).
 - j. To reduce a fire hazard, keep machine free of grass, leaves, or other debris build-up. Clean up oil or fuel spillage and remove any fuel soaked debris.
 - k. Allow machine to cool at least 5 minutes before storing.

Operation

1. Do not put hands and feet near rotating parts or in the feeding chambers and discharge opening. Contact with the rotating impeller can amputate fingers, hands, and feet.
2. Before starting the machine, make sure the chipper chute, feed intake, and cutting chamber are empty and free of all debris.
3. Thoroughly inspect all material to be shredded and remove any metal, rocks, bottles, cans, or other foreign objects which could cause personal injury or damage to the machine.
4. If the impeller strikes a foreign object or if your machine should start making an unusual noise or vibration, immediately shut the engine off. Allow the impeller to come to a complete stop. Disconnect the spark plug wire, ground it against the engine and perform the following steps:
 - a. Inspect for damage.
 - b. Repair or replace any damaged parts.
 - c. Check for any loose parts and tighten to assure continued safe operation.
5. Do not allow an accumulation of processed material to build up in the discharge area. This can prevent proper discharge and result in kickback of material through the feed opening.
6. Do not attempt to shred or chip material larger than specified on the machine or in this manual. Personal injury or machine damage could result.
7. Never attempt to unclog either the feed intake or discharge opening while the engine is running. Shut the engine off, wait until all moving parts have stopped, disconnect the spark plug wire and ground it against the engine before clearing debris.
8. Never operate without vacuum bag and discharge chute properly attached to the machine. Never empty or change vacuum bag while the engine is running. Zippered end of vacuum bag must be kept closed at all times during operation.
9. Never operate without either the inlet nozzle or optional hose attachment properly attached to the machine. Never attempt to attach or change either attachment while the engine is running.
10. Keep all guards, deflectors and safety devices in place and operating properly.
11. Keep your face and body back and to the side of the chipper chute while feeding material into the machine to avoid accidental kickback injuries.
12. Never operate this machine without good visibility or light. Always be sure of your footing and keep a firm hold on the handles.
13. Do not operate this machine on a gravel surface.
14. Do not operate this machine while under the influence of alcohol or drugs.
15. Muffler and engine become hot and can cause a burn. Do not touch.
16. Never pick up or carry machine while the engine is running.

Maintenance & Storage

1. Never tamper with safety devices. Check their proper operation regularly.
2. Check bolts and screws for proper tightness at frequent intervals to keep the machine in safe working condition. Also, visually inspect machine for any damage and repair, if needed.
3. Before cleaning, repairing, or inspecting, stop the engine and make certain the impeller and all moving parts have stopped. Disconnect the spark plug wire and ground it against the engine to prevent unintended starting.
4. Do not change the engine governor settings or overspeed the engine. The governor controls the maximum safe operating speed of the engine.
5. Maintain or replace safety and instruction labels, as necessary.
6. Follow this manual for safe loading, unloading, transporting, and storage of this machine.
7. Never store the machine or fuel container inside where there is an open flame, spark or pilot light such as a water heater, furnace, clothes dryer, etc.
8. Always refer to the operator's manual for proper instructions on off-season storage.
9. If the fuel tank has to be drained, do this outdoors.
10. Observe proper disposal laws and regulations for gas, oil, etc. to protect the environment.

Do not modify engine

To avoid serious injury or death, do not modify engine in any way. Tampering with the governor setting can lead to a runaway engine and cause it to operate at unsafe speeds. Never tamper with factory setting of engine governor.

Notice regarding Emissions

Engines which are certified to comply with California and federal EPA emission regulations for SORE (Small Off Road Equipment) are certified to operate on regular unleaded gasoline, and may include the following emission control systems: Engine Modification (EM) and Three Way Catalyst (TWC) if so equipped.

Your Responsibility

Restrict the use of this power machine to persons who read, understand and follow the warnings and instructions in this manual and on the machine.

2

Safe Operation Practices



WARNING

This symbol points out important safety instructions, which if not followed, could endanger the personal safety and/or property of yourself and others. Read and follow all instructions in this manual before attempting to operate this machine. Failure to comply with these instructions may result in personal injury. When you see this symbol.

HEED IT'S WARNING!

Your Responsibility

Restrict the use of this power machine to persons who read, understand and follow the warnings and instructions in this manual and on the machine.

3

Setting Up Your Chipper Shredder Vacuum



IMPORTANT

This unit is shipped without gasoline or oil in the engine. Be certain to service engine with gasoline and oil as instructed in the separate engine manual before operating your machine.

NOTE: All references in this manual to the left or right side of the chipper shredder vacuum is from the operating position only. Exceptions, if any, will be specified.

NOTE: The metal tab on the nozzle must depress the safety switch button attached to the front of the chipper shredder vacuum or the engine will not start.

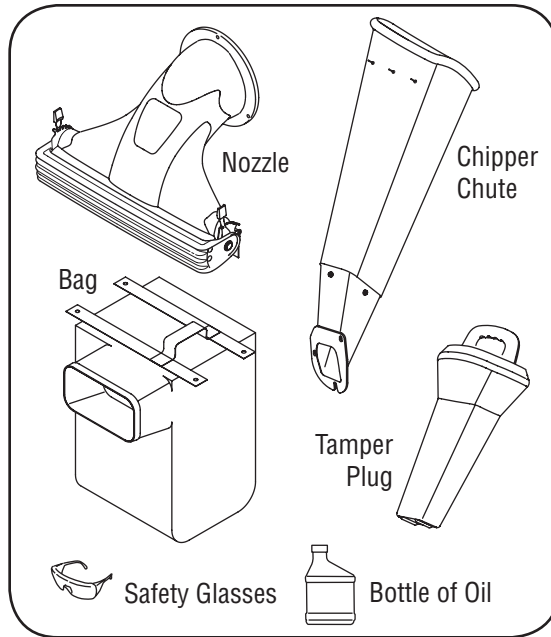

Figure 3-1

IMPORTANT: This unit is shipped without gasoline or oil in the engine. Be certain to service engine with gasoline and oil as instructed in the separate engine manual before operating your machine.

Loose Parts In Carton

1. Following is the list of loose parts shipped with your equipment. Compare the parts with the illustration in Figure 3-1 to identify these items.
 - a. Nozzle
 - b. Bag
 - c. Chipper Chute
 - d. Engine Oil (May be located in bag)
 - e. Safety Glasses
 - f. Tamper Plug (If Equipped)

NOTE: All references in this manual to the left or right side of the yard vacuum is from the operating position only. Exceptions, if any, will be specified.

Attaching The Nozzle

2.
 - a. Remove three wing nuts from the front of the chipper shredder vacuum. See Figure 3-2.
 - b. Place nozzle in position over three studs on unit.
 - c. Secure with wing nuts just removed. See Figure 3-2.

NOTE: The metal tab on the nozzle must depress the safety switch button attached to the front of the chipper shredder vacuum or engine will not start. See Figure 3-2.

Attaching The Chipper Chute

3. Loosen, but do not remove, the two hex bolts, flat washers, and flange nuts which are secured to the support bracket. See Figure 3-3.

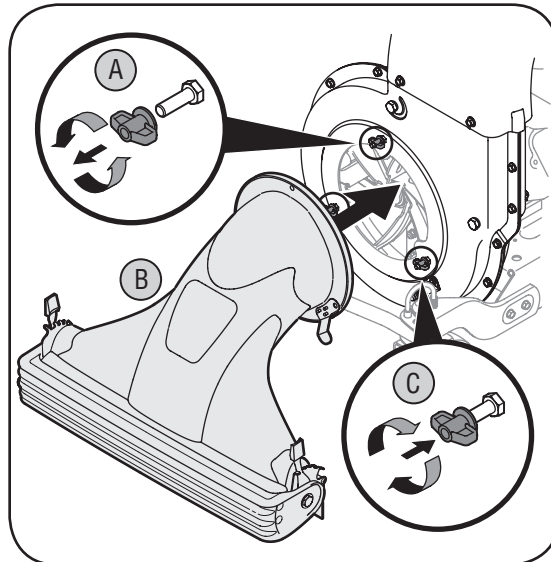

Figure 3-2

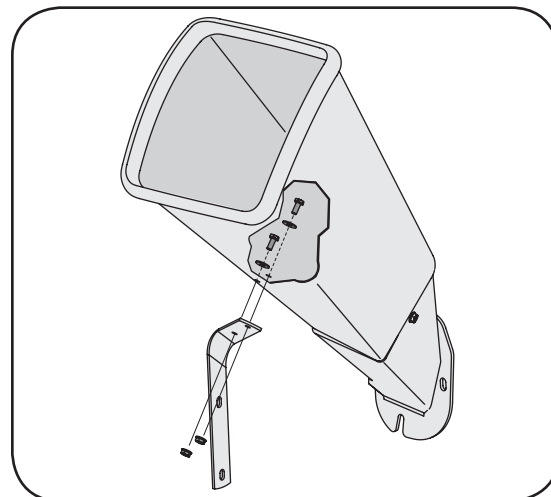

Figure 3-3

3

Setting Up Your Chipper Shredder Vacuum



4. a. Remove the two flange nuts, hex bolts and saddle washers which secure the right side of the upper handle to the right side of the lower handle. See Figure 3-4.
- b. Remove the three hex nuts and bell washers from the weld studs beside the opening on the right side of the chipper-shredder vacuum. See Figure 3-4.
5. a. Place the chipper chute over the weld studs keeping the slotted side towards the bottom. Loosely secure with the three hex nuts and bell washers that were removed earlier. Do not fully tighten the hex nuts at this point in the assembly. See Figure 3-5.
- b. Align the support bracket with the holes in the right side of the upper and lower handles where the hex bolts were just removed. Push up slightly on the chipper chute in order to better align the holes in the support bracket with the holes in the handles.
- c. Replace the hex bolts, saddle washers and flange nuts to affix the support bracket to the handle assemblies. See Figure 3-5.
- d. Follow by tightening all hardware securely first on the chipper chute, then on the support bracket, and finally on the handle.

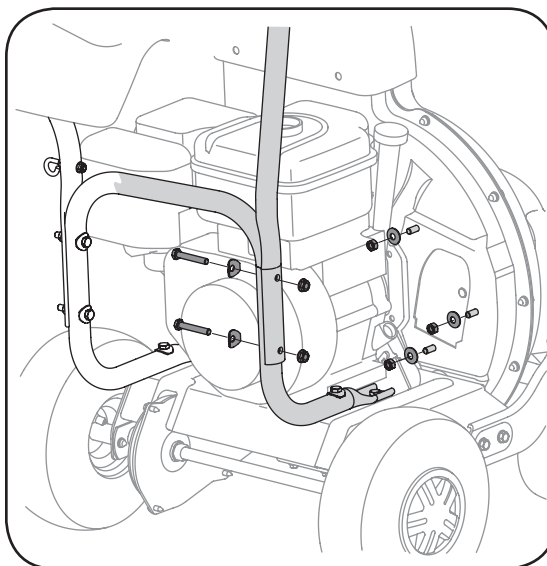

Figure 3-4

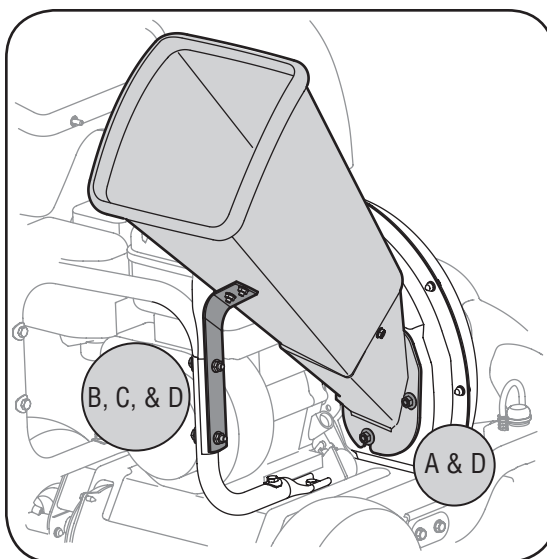

Figure 3-5

Attaching The Bag

6. a. Place bag under the upper handle assembly and slip the front opening on the bag over the discharge chute, making certain it is over the rim on the discharge chute. Follow direction of the arrows in Figure 3-6.
- b. Place the four straps on top of the bag over the upper handle, hooking them on the studs to secure in place. See Figure 3-6.
7. Squeeze the clamp on the drawstring and pull the drawstring tight. Release the clamp. See Figure 3-7.

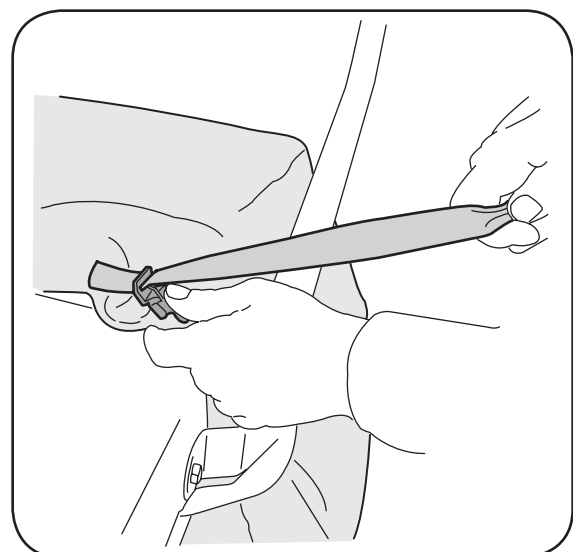

Figure 3-7

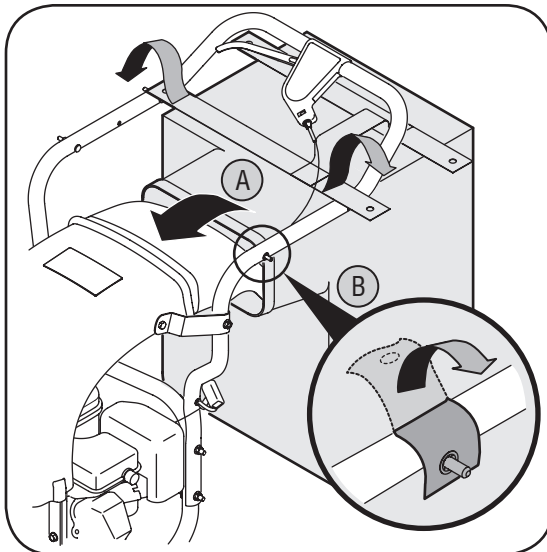

Figure 3-6

4

Setting Up Your Chipper Shredder Vacuum



WARNING

Be familiar with all controls and their proper operation. Know how to stop the machine and disengage them quickly.

Always wear safety glasses during operation or while performing any adjustments or repairs.

Thrown objects which ricochet can cause serious injury to the eyes.

Know Your Chipper Shredder Vacuum

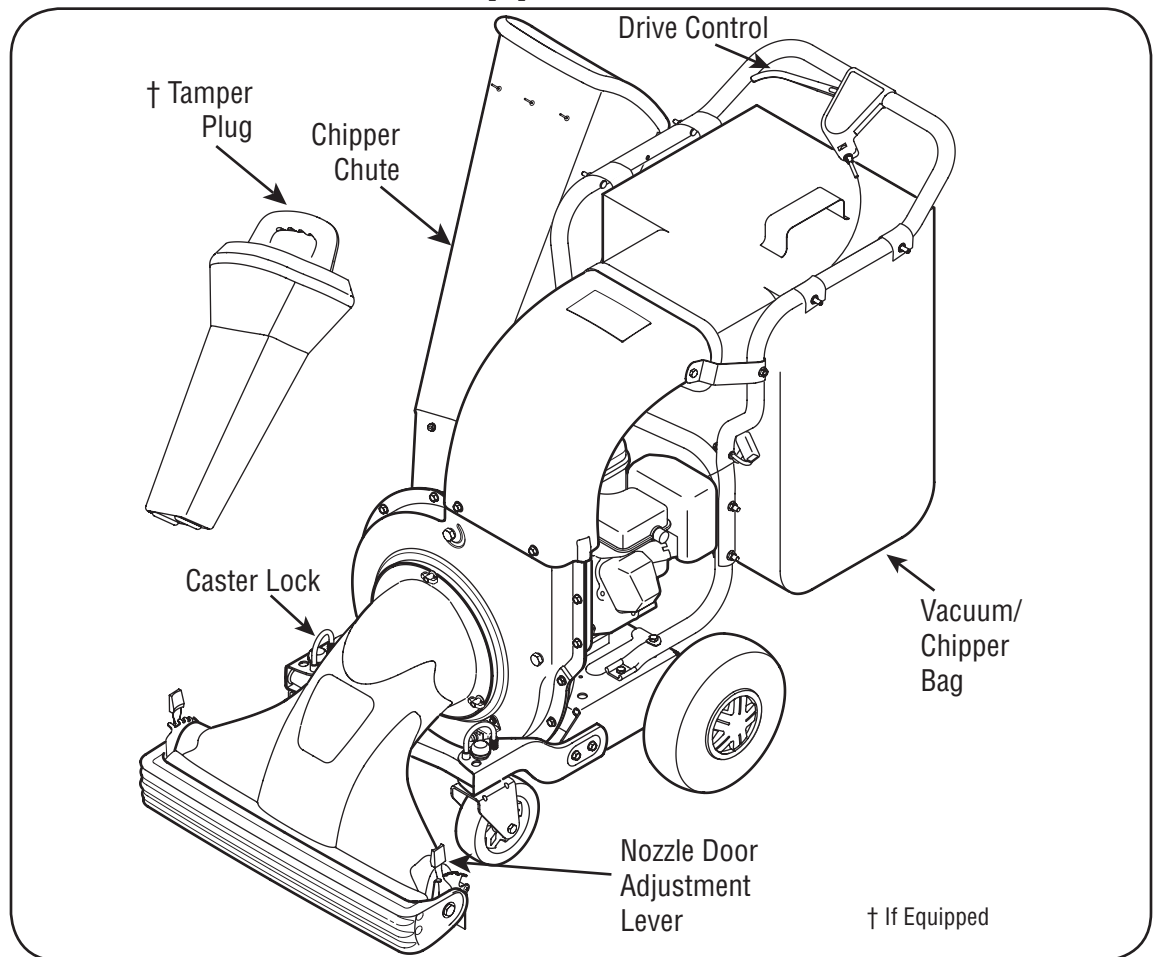

Figure 4-1



WARNING: Be familiar with all controls and their proper operation. Know how to stop the machine and disengage them quickly.

Now that you have set up your yard vacuum for operation, get acquainted with its controls and features. These are described below and illustrated on this page. This knowledge will allow you to use your new equipment to its fullest potential.

Chipper Chute

Allows twigs and small branches up to 3" in diameter to be fed into the impeller for chipping. See Figure 4-1.

Tamper Plug (If Equipped)

This plug is inserted into the chipper chute to push twigs and small branches towards the impeller blades without endangering your hands.

Nozzle Door Adjustment Levers

The nozzle adjustment levers are located on each side of the nozzle door. They are used to adjust nozzle door for ground clearance that will provide the best performance for the operating conditions. See Figure 4-1.

Vacuum/Chipper Bag

Collects shredded or chipped material fed through the chipper chute or vacuumed up through the nozzle.

Drive Control

The drive control is located on the upper handle assembly. Squeezing the drive control against the upper handle engages the rear wheels. Release the drive control to slow down or stop wheel drive. See Figure 4-1.

Caster Locks

The caster locks are located on top of each front caster wheel. Refer to the Adjustment Section to position wheel locks. See Figure 4-1.



WARNING: Always wear safety glasses during operation or while performing any adjustments or repairs. Thrown objects which ricochet can cause serious injury to the eyes.

Engine Controls

See the separate engine manual for the location and function of the controls on the engine.

Gas and Oil Fill-Up

Service the engine with gasoline and oil as instructed in the engine manual. Read instructions carefully.



WARNING: Use extreme care when handling gasoline. Gasoline is extremely flammable and the vapors are explosive. Never fuel machine indoors or while

the engine is hot or running. Extinguish cigarettes, cigars, pipes, and other sources of ignition.

Starting Engine



WARNING: Keep bystanders, helpers, pets, and children at least 75 feet from the machine before starting and while operating. Do not operate this machine

unless the discharge chute and bag have been properly installed and secured to the machine.

1. Attach spark plug wire to spark plug. Make certain the metal cap on the end of the spark plug is fastened securely over the metal tip on the spark plug.

2. Make certain drive control is in the disengaged (released) position.

3. Engines with choke lever:

Move choke lever on engine to CHOKE position. (A warm engine may not require choking).

Engines with primer:

Prime engine as instructed in separate engine manual.

4. Move engine throttle control lever to FAST or START position.

5. Place one foot on the left rear wheel to prevent the unit from skidding while starting.

6. Grasp starter handle and pull rope out slowly until engine reaches start of compression cycle (rope will pull slightly harder at this point).

NOTE: A noise will be heard at the start of the compression cycle, which will continue to be heard till the impeller reaches full speed.

7. Keeping a firm grip on the starter handle, pull rope with a rapid, continuous, full arm stroke. Let the rope rewind slowly.

8. Repeat the previous steps until engine fires. When engine starts, move choke control (if equipped) gradually to RUN position.

NOTE: See your engine manual packed with your unit for more detailed instructions.

Stopping The Engine

1. Move throttle control lever to STOP or OFF position.
2. Disconnect spark plug wire from spark plug and ground against the engine.

To Empty Bag

1. Open the large zipper in the rear of the bag to empty the contents. Be certain the zipper is closed completely when operating the unit.
2. If bag is removed for any reason, follow instructions for attaching the bag in the "Setting Up Your Chipper Shredder Vacuum" section.

To Engage Drive

- To engage the wheel drive, hold the drive control against the upper handle.
- Release the drive control to stop the rear wheels from driving.
- Release the drive control to slow down when negotiating an obstacle, making a turn, or stopping.
- Engage control slowly to prevent the front wheels from lifting up.

Using the Chipper Shredder Vacuum

- Place both hands on top of the upper handle and hold the drive control against the upper handle to propel the unit over yard. Yard waste such as leaves and pine needles can be vacuumed up through the nozzle for shredding.
- After material has been shredded by the blades on the impeller assembly, it will be discharged into catcher bag.
- Branches up to three inches in diameter can be fed into the chipper chute.

IMPORTANT: Do not attempt to shred or chip any material other than vegetation found in a normal yard (i.e. branches, leaves, twigs, etc.) Avoid fibrous plants such as tomato vines until they are thoroughly dried out. Materials such as stalks or heavy branches up to 3" in diameter may be fed into the chipper chute.



WARNING: Do not attempt to shred, chip, or vacuum any material larger than specified on the machine or in this manual. Personal injury or damage to the machine could result.

IMPORTANT: The flail screen is located inside the housing in the discharge area. If the flail screen becomes clogged, remove and clean as instructed in the Maintenance section. For best performance, it is also important to keep the chipper blade sharp.

4

Setting Up Your Chipper Shredder Vacuum



WARNING

Use extreme care when handling gasoline. Gasoline is extremely flammable and the vapors are explosive. Never fuel machine indoors or while the engine is hot or running. Extinguish cigarettes, cigars, pipes, and other sources of ignition.

Keep bystanders, helpers, pets, and children at least 75 feet from the machine before starting and while operating. Do not operate this machine unless the discharge chute and bag have been properly installed and secured to the machine.

5

Maintaining Your Chipper Shredder Vacuum



WARNING

Always stop engine, disconnect spark plug, and ground against engine before cleaning, lubricating or doing any kind of maintenance on your machine.

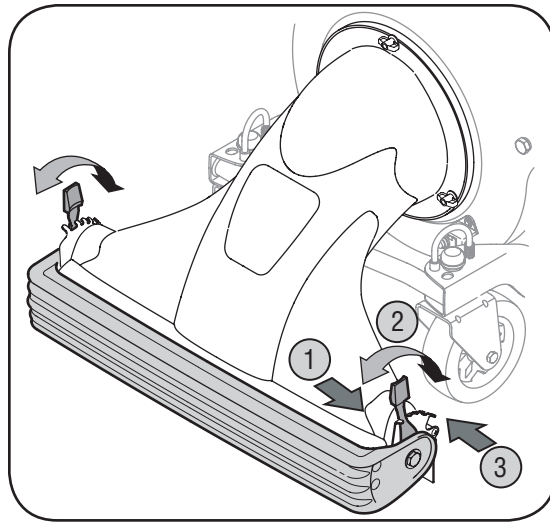

Figure 5-1

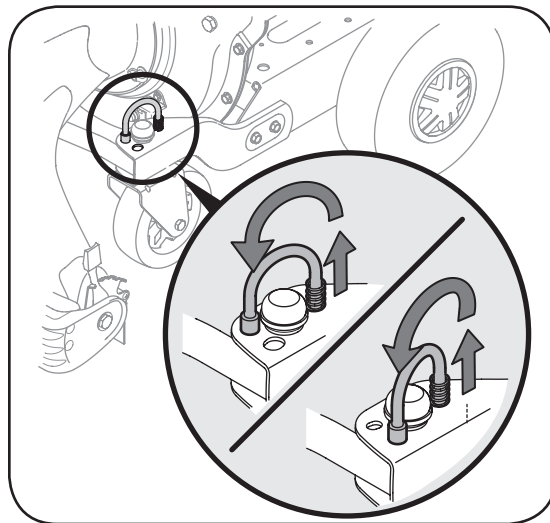

Figure 5-2



WARNING: Always stop engine and disconnect spark plug wire before cleaning, lubricating or doing any kind of maintenance on your machine.

Lubrication

1. **Wheels:** Lubricate the rear wheels with light oil once a season.
2. **Nozzle Door Adjustment Levers:** Lubricate each adjustment lever once a season with light oil.
3. **Front Caster Wheels:** Grease fittings are located on the front caster wheels to provide easy lubrication of the swivel pins.

Engine Maintenance

Refer to the separate engine manual for all engine maintenance instructions.

1. Check **engine oil level** before each use as instructed in the separate engine manual packed with your unit. Read and follow instructions carefully.
2. Clean **air cleaner** every 25 hours under normal conditions or once a season. Clean every few hours

under extremely dusty conditions. To service the air cleaner, refer to the separate engine manual packed with your unit.

3. The **spark plug** should be cleaned and the gap reset once a season. Check engine manual for correct plug type and gap specifications.

Nozzle Door Height Adjustment

The nozzle adjustment levers are located on each side of the nozzle door. The nozzle door can be adjusted to one of five positions, ranging from 1/2" to 3" ground clearance, to provide best performance.

1. Push adjustment lever out away from nozzle.
2. Slide the height adjustment lever forward or backward for adjusting the nozzle door upwards or downwards. See Figure 5-1.
3. Release lever towards nozzle.

NOTE: Height must be adjusted equally. In general, raise the nozzle to vacuum a thick layer of leaves and lower the nozzle for smooth surfaces.

Drive Control Cable Adjustment

Adjust the drive control if:

- a. The chipper shredder vacuum moves forward with the drive control disengaged.
- b. It does not self-propel with the drive control engaged.
- c. Drive belt is slipping (unit hesitates while engine maintains the same speed).

Use the adjustment wheel located in the control housing to tighten or loosen the drive control cable until the above situation is corrected.

In addition, the adjustment wheel may also be used to determine the position in which the drive control is engaged. If it is more comfortable to have the drive engaged with the lever further away from the handle, tighten the cable.

Front Caster Wheels

This chipper shredder vacuum is equipped with front caster wheels. The casters can be locked in a straight ahead position or to swivel freely.

1. Lift and place pins in the larger holes for locked or straight ahead operation and when operating on slopes. See Figure 5-2.
2. Place pins in smaller holes to allow casters to rotate freely for maneuvering around trees and flower beds.

Cleaning The Flail Screen

If the discharge area becomes clogged, remove the flail screen and clean area as follows.

1. Stop the engine. Make certain the chipper/shredder vacuum has come to a complete stop.
2. Disconnect spark plug wire from spark plug and ground against the engine.

3. Remove and set aside the vacuum bag.
4.
 - a. Remove the four self-tapping screws from the bottom of the discharge chute. See Figure 5-3.
 - b. Remove the hex bolt, saddle washer and hex nut from the top and remove the discharge chute assembly. See Figure 5-3.
5.
 - a. Remove the two hex bolts and hex nuts which extend through the impeller housing.
 - b. Lift the flail screen from inside the housing. See Figure 5-4.
6. Clean the flail screen by scraping and/or washing with water, and reinstall the screen.

NOTE: Be certain to reassemble the flail screen with the curved side down.

7. Reattach the discharge chute assembly with the hardware previously removed and attach the bag to the unit.

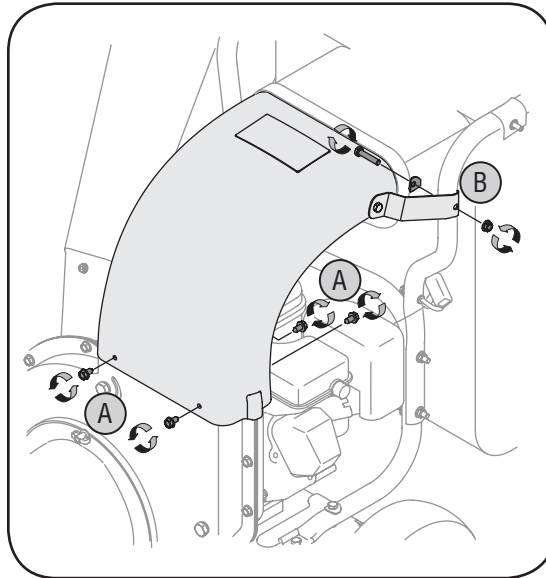

Figure 5-3

Sharpening Or Replacing Chipper Blades

NOTE: When tipping the unit, empty the fuel tank and keep engine spark plug side up.

1. Disconnect spark plug wire and ground it against engine.
2. Remove flail screen as instructed in previous section.
3.
 - a. Remove plastic belt cover from front of the engine by removing the two self-tapping screws. See Figure 5-5 on next page.
 - b. Remove the access plate by removing two hex lock nuts.
 - c. Locate one of the chipper blades in the access opening by rotating the impeller assembly by hand. Remove the chipper blade using a 3/16" allen wrench and a 1/2" wrench. See Figure 5-5.
4. Remove other blade in the same manner to replace or sharpen.

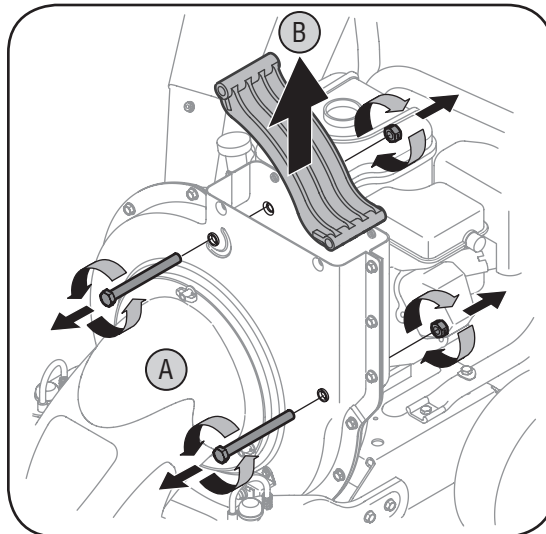

Figure 5-4



WARNING: Use caution when replacing the blades. Wear heavy gloves to avoid injury while handling the weld bolts, housing or the blades.

NOTE: When sharpening blades, follow the original angle of grind. Also, make sure to remove an equal amount from each blade and torque hardware to 250 - 300 in.lb.

IMPORTANT: Make sure that blades are reassembled with the sharp edge facing upward.

Tire Pressure (Pneumatic tires only)

Maximum tire pressure under any circumstance is 30 psi. Equal tire pressure should be maintained at all times assembly.

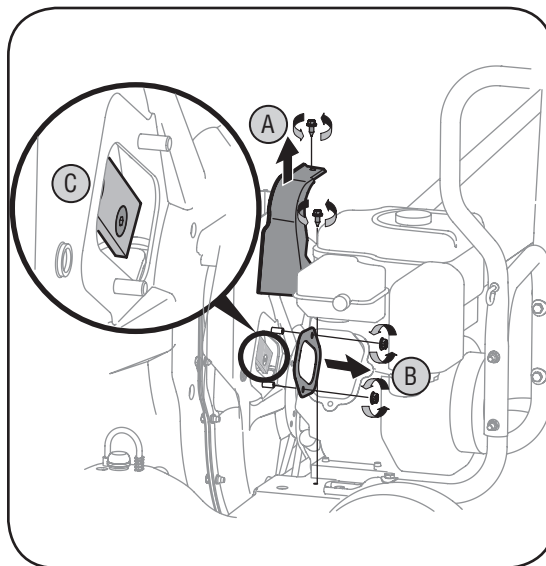

Figure 5-5

5

Maintaining Your Chipper Shredder Vacuum



WARNING

Use caution when replacing the blades. Wear heavy gloves to avoid injury while handling the weld bolts, housing or the blades.



NOTE: Be certain to reassemble the flail screen with the curved side down.

NOTE: When sharpening blades, follow the original angle of grind. Also, make sure to remove an equal amount from each blade and torque hardware to 250 - 300 in.lb.

6

Trouble Shooting



For repairs beyond the minor adjustments listed here, contact an authorized service dealer.

Problem	Cause	Remedy
Engine fails to start	<ol style="list-style-type: none"> 1. Throttle lever not in correct starting position. 2. Spark plug wire disconnected. 3. Choke not in CHOKE position (if equipped). 4. Fuel tank empty or stale fuel. 5. Engine not primed (if equipped). 6. Faulty spark plug. 7. Engine flooded. 	<ol style="list-style-type: none"> 1. Move throttle lever to FAST or START position. 2. Connect wire to spark plug. 3. Move choke lever to CHOKE position. 4. Fill tank with clean, fresh gasoline. 5. Prime engine as instructed in Engine Manual. 6. Clean, adjust gap, or replace. 7. Wait a few minutes to restart, but do not prime.
Engine runs erratic	<ol style="list-style-type: none"> 1. Spark plug wire loose. 2. Unit running on CHOKE (if equipped). 3. Blocked fuel line or stale fuel. 4. Low engine RPM. 5. Water or dirt in fuel system. 6. Dirty air cleaner. 7. Carburetor out of adjustment. 	<ol style="list-style-type: none"> 1. Connect and tighten spark plug wire. 2. Move choke lever to OFF position. 3. Clean fuel line; fill tank with clean, fresh gasoline. 4. Always run engine at full throttle. 5. Drain fuel tank. Refill with fresh fuel. 6. Refer to engine manual. 7. See authorized service dealer.
Engine overheats	<ol style="list-style-type: none"> 1. Engine oil level low. 2. Dirty air cleaner. 3. Carburetor not adjusted properly. 	<ol style="list-style-type: none"> 1. Fill crankcase with proper oil. 2. Refer to engine manual. 3. See authorized service dealer.
Occasional skips (hesitates) at high speed	<ol style="list-style-type: none"> 1. Spark plug gap too close. 2. Carburetor idle mixture adjustment improperly set. 	<ol style="list-style-type: none"> 1. Remove spark plug and adjust gap 2. See authorized service dealer.
Excessive Vibration	<ol style="list-style-type: none"> 1. Loose parts or damaged impeller. 	<ol style="list-style-type: none"> 1. See authorized service dealer.
Unit does not discharge	<ol style="list-style-type: none"> 1. Discharge area clogged. 2. Foreign object lodged in impeller. 3. Low engine RPM. 4. Vacuum bag is full. 	<ol style="list-style-type: none"> 1. Stop engine immediately and disconnect spark plug wire. Clean flail screen and inside of discharge opening. 2. Stop engine and disconnect spark plug wire. Remove lodged object. 3. Always run engine at full throttle. 4. Empty bag.
Rate of discharge slows considerably or composition of discharged material changes	<ol style="list-style-type: none"> 1. Low engine RPM. 2. Chipper blade dull. 	<ol style="list-style-type: none"> 1. Always run engine at full throttle. 2. Replace chipper blade or see your authorized service dealer.

Storing Your Yard Vacuum

1. Clean the equipment thoroughly.
2. Wipe equipment with an oiled rag to prevent rust.
3. Refer to engine manual for correct engine storage instructions.
4. Store unit in a clean, dry area. Do not store next to corrosive materials such as fertilizer.



WARNING: Never store the machine or fuel container indoors where there is an open flame, spark, or pilot light such as on a water heater, furnace, clothes dryer, or other gas appliance.

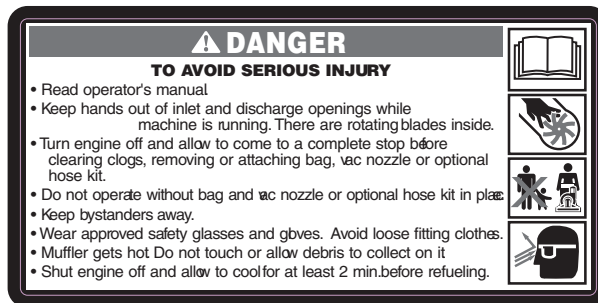
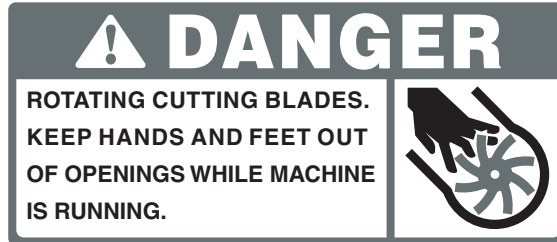

7

Off Season Storage & Safety Labels



WARNING

DO NOT remove safety (or any) labels from chipper shredder vacuum for any reason.

Never store the machine or fuel container indoors where there is an open flame, spark, or pilot light such as on a water heater, furnace, clothes dryer, or other gas appliance.

Model 204

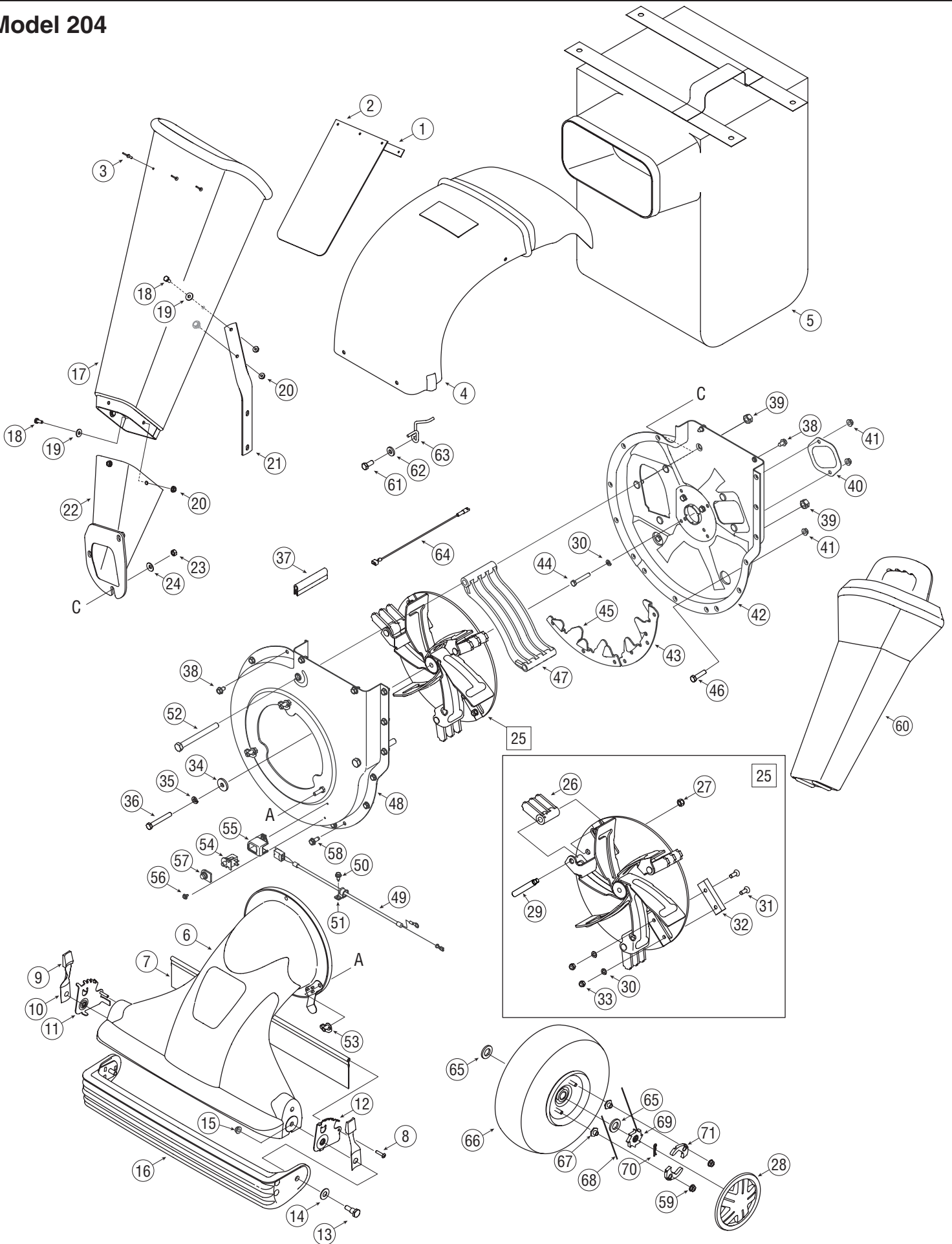

1.	781-0633	Chute Flap Strip
2.	735-0249	Chute Flap
3.	728-0175	Pop Rivet
4.	731-1838A	Discharge Chute
5.	764-04001	Bag
6.	631-0086	Nozzle Assembly
7.	731-1831	Nozzle Flap
8.	710-0969	Screw
9.	720-0426	Height Adjustment Knob
10.	732-0754	Spring Lever
11.	781-0702	Index Bracket RH
12.	781-0703	Index Bracket LH
13.	738-0913	Shoulder Screw
14.	736-3084	Flat Washer.510 x 1.12 x.060
15.	712-0431	Hex Flange Lock Nut 3/8-16
16.	631-0049	Door Assembly
17.	731-1574A	Chipper Chute
18.	710-0751	Hex Cap Screw 1/4-20 x.620
19.	736-0173	Flat Washer.28 ID x.74 OD
20.	712-3027	Hex Lock Nut 1/4-20
21.	781-0780	Support Bracket
22.	681-0068A	Chipper Chute Assembly
23.	712-3010	Hex Nut, 5/16-18
24.	736-0242	Belleville Washer,.340ID x.872OD
25.	681-04091	Impeller Assembly: Complete
26.	719-04308	Flail Blade
27.	712-0266A	Jam Lock Nut, 3/8-16
28.	734-1984	Hub Cap
29.	738-04286	Shoulder Pin, .5 x 2.625
30.	736-0119	Lock Washer 5/16
31.	710-1054	Cap Screw 5/16-24 x 1.0
32.	742-0544A	Chipper Blade
33.	712-0411	Hex Lock Nut 5/16-24
34.	736-0247	Flat Washer.406 x 1/1/4
35.	736-0217	Lock Washer 3/8
36.	710-1273	Hex Cap Screw 3/8-24 x 2.75
37.	723-0438	Rubber Seal

38.	710-0604A	Hex Washer Screw 5/16-18
39.	712-0384	Hex Lock Nut 1/2-13
40.	781-0627	Chipper Blade Cover
41.	712-3004A	Hex Flange Lock Nut 5/16-18
42.	681-0098	Housing Assembly: Inner Flail
43.	781-0599	Upper Shredder Blade
44.	710-0772	Hex Cap Screw 5/16-18 x 2
45.	781-0653	Flail Housing Blade
46.	710-3008	Hex Cap Screw 5/16-18 x.75
47.	719-0326	Discharge Screen
48.	681-0060	Housing Assembly: Outer Flail
49.	629-0241A	Wire Harness
50.	710-0896	TT Screw 1/4-14 x 0.625"
51.	726-0272	Clamp
52.	710-0382	Hex Cap Screw 1/2-13 x 5.0
53.	712-0421	Knob 5/16-18
54.	725-3166	Switch
55.	731-1613	Safety Switch Mounting Cover
56.	710-1268	Hex Washer Screw
57.	725-1700	Switch Cover
58.	710-1260A	LD Screw 5/16-18 x 0.75"
59.	712-3027	Hex Flanged Lock Nut 1/4-20
60.	731-1617†	Tamper Plug
61.	710-0157	Hex Cap Screw 5/16-24 x.75
62.	736-3008	Flat Washer.344 x.75 x.12
63.	747-0929A	Belt Keeper
64.	629-0923	Adapter Harness Assembly
65.	736-0366	Flat Washer 5/8 ID x 1.0 OD
66.	634-0244	Wheel Complete 10 x 4 x 4
67.	712-0456	Hex Nut 1/4-20
68.	10622B	Plastic Spring Ratchet
69.	748-0405	Wheel Ratchet 1.62 OD x.5 serr
70.	714-0104	Cotter Pin
71.	748-0188B	Pawl LH.345 ID
	748-0381	Pawl RH.345 ID
—	725-0157	Cable Tie (Not Shown)
—	723-0400	Safety Glasses (Not Shown)

† If Equipped

8

Parts List



To order replacement parts, contact
1-800-828-5500,
1-330-558-7220
 or visit
www.troybilt.com.

Model 204

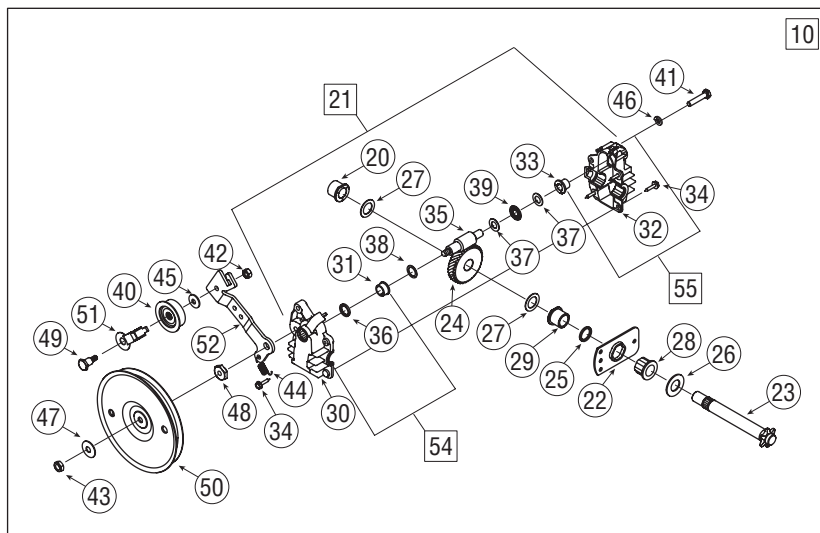
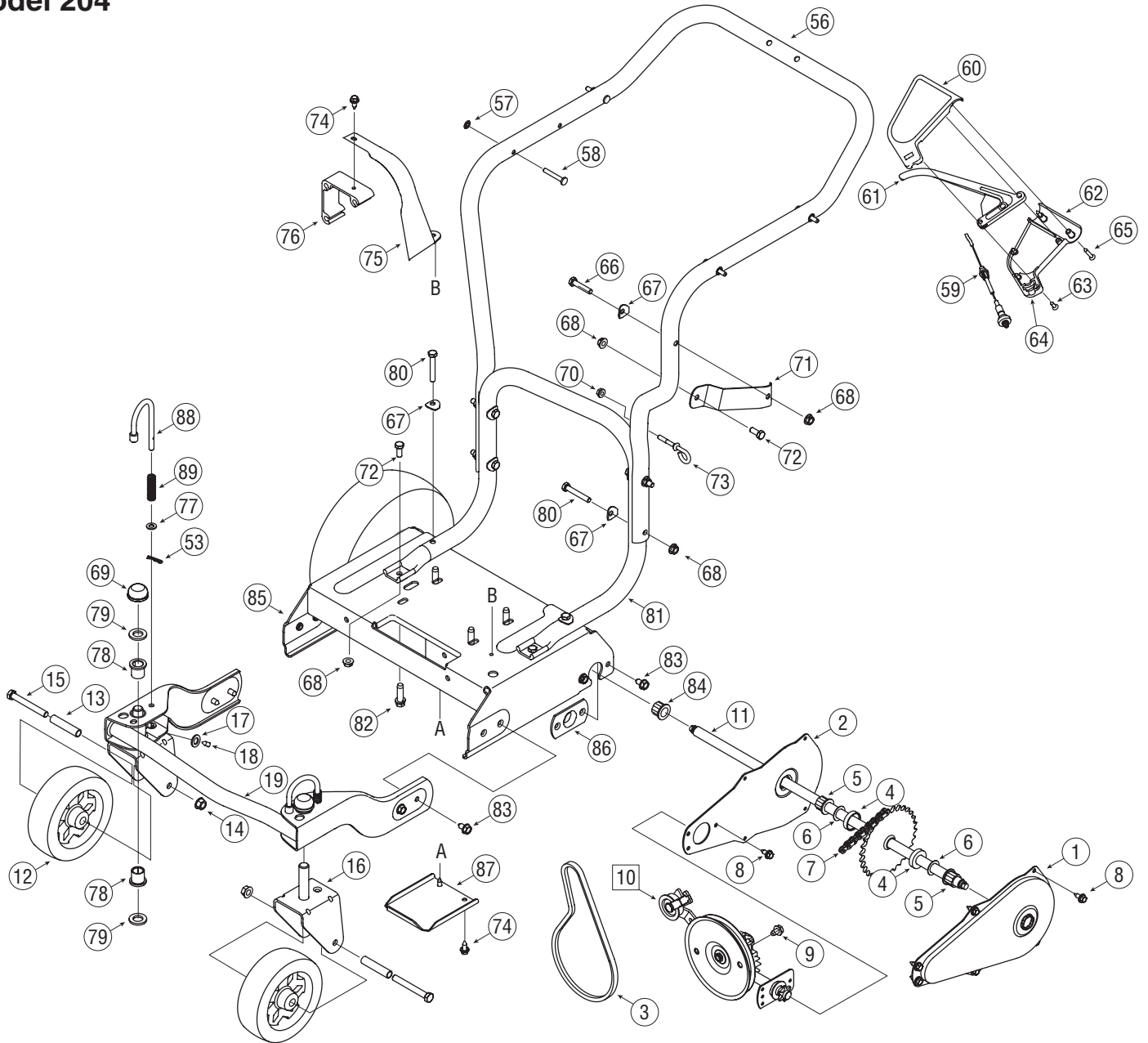

1.	781-0677	Chain Case LH
2.	781-0676	Chain Case RH
3.	754-0457	V-Belt
4.	748-0313	Spacer
5.	741-0413	Hex Flange Bearing
6.	736-0336	Flat Washer
7.	713-0422	Chain
8.	710-0896	TT Screw 1/4-14 x 0.625"
9.	710-0603	Hex Washer Screw 5/16
10.	618-0256	Chipper Shredder Trans. Ass'y.
11.	611-0063	Axle Assembly
12.	734-1804A	Wheel 6.0 x 2.0
13.	750-1042	Spacer
14.	712-0431	Flange Lock Nut 3/8-16
15.	710-0521	Hex Cap Screw 3/8-16 x 3.0
16.	681-0088	Bracket Assembly
17.	736-0931	Flat Washer.203 ID x.403 OD
18.	737-3000	Grease Fitting 3/16
19.	681-0087	Bracket Assembly
20.	741-0415	Flange Bearing.566 ID
21.	618-0255	Shredder Transmission Assembly
22.	16500A	Hex Bearing Cup
23.	711-1118	Output Shaft 6T Sprocket
24.	717-1432	Helical 34T Gear
25.	721-0213	Oil Seal
26.	736-0187	Flat Washer.64 ID x 1.24 OD
27.	736-0336	Flat Washer 5/8 x 1.0
28.	741-0413	Hex Flange Bearing.631 ID
29.	741-0414	Flange Bearing.629 ID
30.	719-0325	Lower Housing
31.	748-0373	Flange Bearing.503 ID
32.	719-0324A	Upper Housing
33.	748-0208A	Flange Bearing.378 ID
34.	710-0589	Hex Washer Screw #10-16 x.75
35.	717-1433	Pinion Shaft 10T
36.	721-0329	Oil Seal
37.	736-0314	Thrust Washer.382 ID x.684 OD
38.	736-0520	Flat Washer.504 ID x.70 OD
39.	741-0479	Thrust Bearing.375 ID x.812 OD
40.	656-0008	Idler Pulley Assembly W/ Bearing
—	756-0558	Idler Pulley Only
—	741-0556	Needle Bearing Only
41.	710-1062	Hex Cap Screw 1/4-20 x 1.25
42.	712-0138	Hex Nut 1/4-28
43.	712-3045	Hex Jam Nut 5/16-24 LH Thd
44.	732-0357A	Extension Spring 1.12 Lg
45.	736-0270	Bell Washer.265 ID x.75 OD
46.	736-0329	Lock Washer 1/4
47.	736-0425	Bell Washer.325 ID x.930 OD
48.	738-0440	Shoulder Spacer.375 ID x.165 OD
49.	738-0826	Shoulder Bolt 1/4-28 x.375
50.	756-0656	Flat Pulley 5.06 Dia
51.	782-7569	Belt Keeper
52.	682-0054	Idler Bracket
53.	714-0104	Cotter Pin
54.	618-0132	Lower Housing Assembly
55.	618-0133A	Upper Housing Assembly
56.	749-1095	Upper Handle
57.	1539-019	Push Nut
58.	711-0737	Stud Pin.250 x 1.75
59.	746-0714	Clutch Cable 56"
60.	731-1735	Upper Clutch Cover
61.	731-0620A	Drive Lever
62.	731-1736	Lower Clutch Cover
63.	710-0841	Screw #10-12 x.750
64.	731-1059	Mounting Cable Cap
65.	710-1331	Screw #10-16 x 1.25
66.	710-0805	Hex Cap Screw 5/16-18 x 1.50
67.	736-0451	Shoulder Washer.320 ID x.93 OD
68.	712-3004A	Hex Flange Lock Nut 5/16-18
69.	726-0214	Push Cap
70.	712-0380	Hex Nut 1/4-28
71.	781-0647	Discharge Chute Bracket
72.	710-3008	Hex Cap Screw 5/16-18 x.75
73.	747-0815	Eye Bolt
74.	710-0896	Hex Washer Screw 1/4-14 x.625
75.	731-1646	Belt Cover
76.	719-0359	Engine Mounting Adapter
77.	736-0264	Flat Washer.330 ID x.630 OD
78.	741-0487C	Flange Bearing.632 ID
79.	736-0366	Flat Washer 5/8 ID x 1.0 OD
80.	710-3103	Hex Cap Screw 5/16-18 x 1.75
81.	749-1094	Lower Push Handle
82.	710-0502A	Screw 3/8-16 x 1.25
83.	710-0604A	Hex Washer Screw 5/16-18 x.625
84.	741-0413	Hex Flange Bearing.631 x.720
85.	681-0097A	Frame Assembly
86.	781-0700	Axle Bracket
87.	781-0697	Transmission Cover
88.	747-0924	Lock Pin
89.	732-0306	Compression Spring

8

Parts List



To order replacement parts, contact
1-800-828-5500,
1-330-558-7220
 or visit
www.troybilt.com.

NOTES

Use this page to take notes and write down important information.

NOTES

Use this page to take notes and write down important information.

MANUFACTURER'S LIMITED WARRANTY FOR



The limited warranty set forth below is given by Troy-Bilt LLC with respect to new merchandise purchased and used in the United States and/or its territories and possessions, and by MTD Products Limited with respect to new merchandise purchased and used in Canada and/or its territories and possessions (either entity respectively, "Troy-Bilt").

"Troy-Bilt" warrants this product (excluding its *Normal Wear Parts and Attachments* as described below) against defects in material and workmanship for a period of two (2) years commencing on the date of original purchase and will, at its option, repair or replace, free of charge, any part found to be defective in materials or workmanship. This limited warranty shall only apply if this product has been operated and maintained in accordance with the Operator's Manual furnished with the product, and has not been subject to misuse, abuse, commercial use, neglect, accident, improper maintenance, alteration, vandalism, theft, fire, water, or damage because of other peril or natural disaster. Damage resulting from the installation or use of any part, accessory or attachment not approved by Troy-Bilt for use with the product(s) covered by this manual will void your warranty as to any resulting damage.

Normal Wear Parts are warranted to be free from defects in material and workmanship for a period of thirty (30) days from the date of purchase. Normal wear parts include, but are not limited to items such as: batteries, belts, blades, blade adapters, tines, grass bags, wheels, rider deck wheels, seats, snow thrower skid shoes, friction wheels, shave plates, auger spiral rubber and tires.

Attachments — Troy-Bilt warrants attachments for this product against defects in material and workmanship for a period of one (1) year, commencing on the date of the attachment's original purchase or lease. Attachments include, but are not limited to items such as: grass collectors and mulch kits.

HOW TO OBTAIN SERVICE: Warranty service is available, WITH PROOF OF PURCHASE, through your local authorized service dealer. To locate the dealer in your area:

In the U.S.A.

Check your Yellow Pages, or contact Troy-Bilt LLC at P.O. Box 361131, Cleveland, Ohio 44136-0019, or call 1-866-840-6483, 1-330-558-7220 or log on to our Web site at www.troybilt.com.

In Canada

Contact MTD Products Limited, Kitchener, ON N2G 4J1, or call 1-800-668-1238 or log on to our Web site at www.mtdcanada.com.

This limited warranty does **not** provide coverage in the following cases:

- a. The engine or component parts thereof. These items may carry a separate manufacturer's warranty. Refer to applicable manufacturer's warranty for terms and conditions.
- b. Log splitter pumps, valves, and cylinders have a separate one-year warranty.

- c. Routine maintenance items such as lubricants, filters, blade sharpening, tune-ups, brake adjustments, clutch adjustments, deck adjustments, and normal deterioration of the exterior finish due to use or exposure.
- d. Service completed by someone other than an authorized service dealer.
- e. Troy-Bilt does not extend any warranty for products sold or exported outside of the United States and/or Canada, and their respective possessions and territories, except those sold through Troy-Bilt's authorized channels of export distribution.
- f. Replacement parts that are not genuine Troy-Bilt parts.
- g. Transportation charges and service calls.
- h. Troy-Bilt does not warrant this product for commercial use.

No implied warranty, including any implied warranty of merchantability of fitness for a particular purpose, applies after the applicable period of express written warranty above as to the parts as identified. No other express warranty, whether written or oral, except as mentioned above, given by any person or entity, including a dealer or retailer, with respect to any product, shall bind Troy-Bilt. During the period of the warranty, the exclusive remedy is repair or replacement of the product as set forth above.

The provisions as set forth in this warranty provide the sole and exclusive remedy arising from the sale. Troy-Bilt shall not be liable for incidental or consequential loss or damage including, without limitation, expenses incurred for substitute or replacement lawn care services or for rental expenses to temporarily replace a warranted product.

Some states do not allow the exclusion or limitation of incidental or consequential damages, or limitations on how long an implied warranty lasts, so the above exclusions or limitations may not apply to you.

In no event shall recovery of any kind be greater than the amount of the purchase price of the product sold. **Alteration of safety features of the product shall void this warranty.** You assume the risk and liability for loss, damage, or injury to you and your property and/or to others and their property arising out of the misuse or inability to use the product.

This limited warranty shall not extend to anyone other than the original purchaser or to the person for whom it was purchased as a gift.

HOW STATE LAW RELATES TO THIS WARRANTY: This limited warranty gives you specific legal rights, and you may also have other rights which vary from state to state.

IMPORTANT: Owner must present Original Proof of Purchase to obtain warranty coverage.

**Troy-Bilt LLC, P.O. BOX 361131 CLEVELAND, OHIO 44136-0019; Phone: 1-866-840-6483, 1-330-558-7220
MTD Canada Limited - KITCHENER, ON N2G 4J1; Phone 1-800-668-1238**