

Fisher-Price

Instructions

Deluxe Port-A-Swing

Model Number 9122

- Please save these instructions for future reference.
- Adult assembly required.
- Weight limit: 25 lbs.

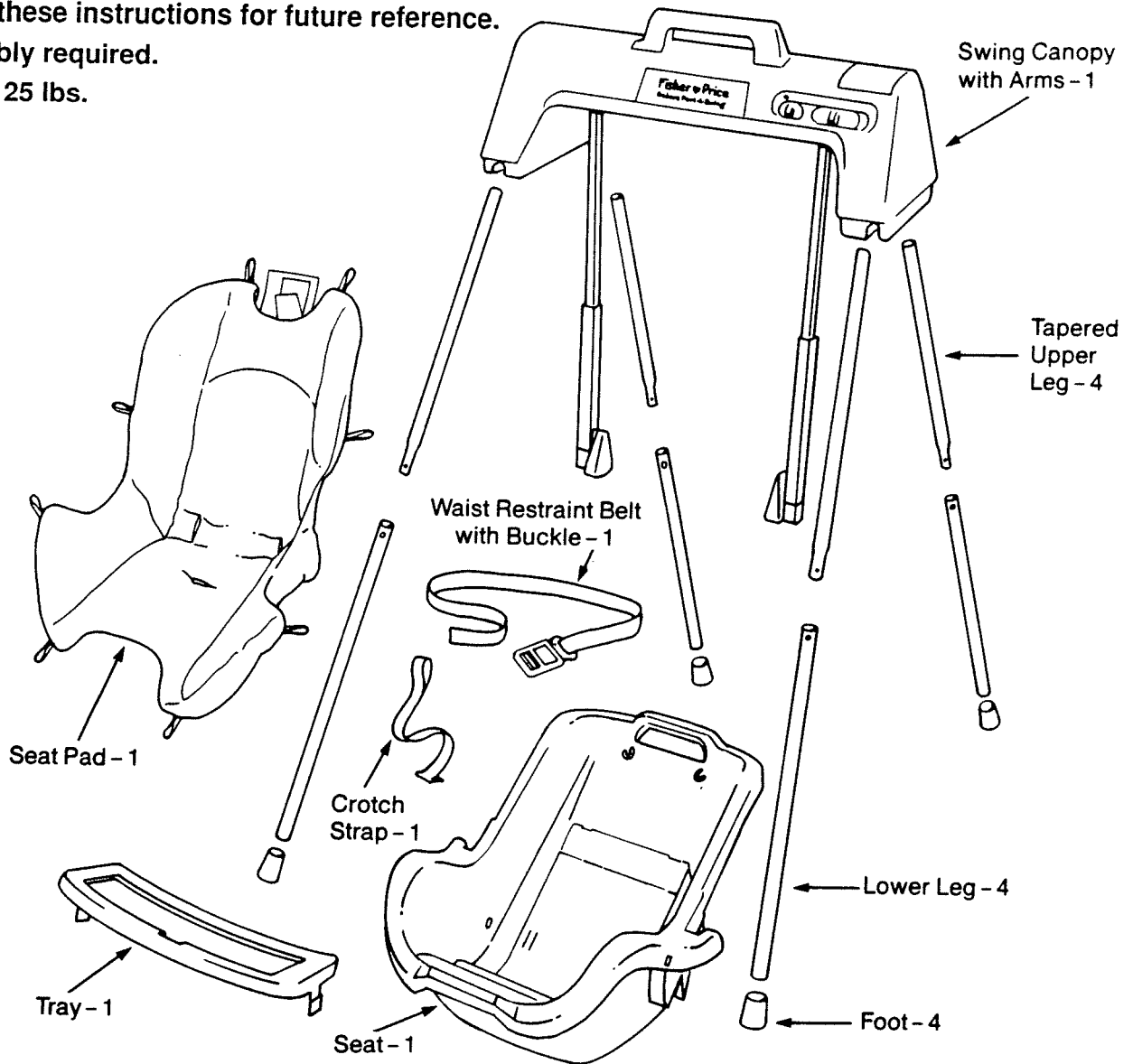

WARNING

- **Never leave child unattended.**
- **To prevent falls:**
 - **Always use the restraint system.**
 - **Never use swing with an active child who may be able to climb out of the seat.**
 - **Always remove child before attaching or detaching seat from swing.**
 - **Never move swing with child in seat.**
- **Never use as a car seat.**

CAUTION

Keep small parts, hardware and plastic bags out of children's reach.

The Fisher-Price Deluxe Port-A-Swing requires adult assembly. Please read these instructions thoroughly and identify all parts before assembly. Refer to the parts illustration above for identification.

If you have any problems with this product, please call Fisher-Price Consumer Affairs, toll free at 1-800-432-KIDS (1-800-432-5437) between 8 AM and 6 PM Eastern time, Monday through Friday, or write to:

Fisher-Price, Inc.
Attn: Consumer Affairs
636 Girard Avenue
East Aurora, New York 14052

ASSEMBLY

Step 1: Legs

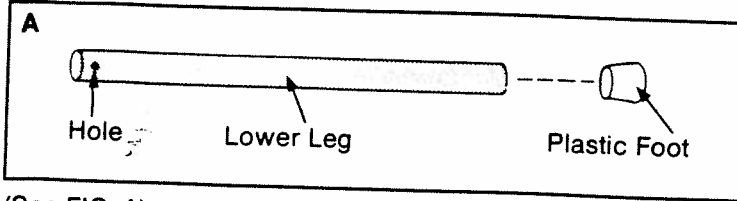

(See FIG. A)

- Attach a plastic foot onto the bottom of a lower leg (end without the hole).
- Repeat this procedure to attach a plastic foot to the other three lower legs.
- Set the lower legs aside for use in the SET-UP section (Step 1, page 3).

Step 2: Restraint Belt

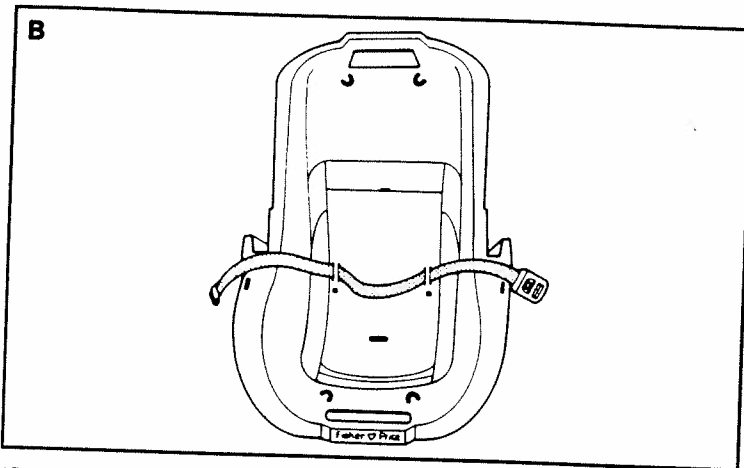

(See FIG. B)

- With the front of the seat facing you, insert the end (without buckle) of the waist restraint belt into the first slot, as shown.
- Insert the belt into the second slot (from back of seat) and pull up.
- Insert the belt into the third slot.
- Insert the belt into the fourth slot (from back of seat) and pull up.

Step 3: Crotch Strap

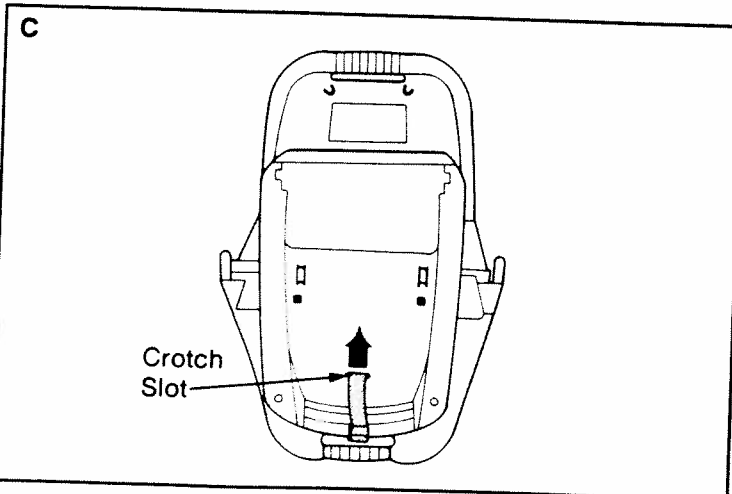

See FIG. C)

- Turn the seat face down.
- Insert the crotch strap (loop first) into the slot in the seat bottom, and pull up from the other side of the seat.

Step 4: Seat Pad

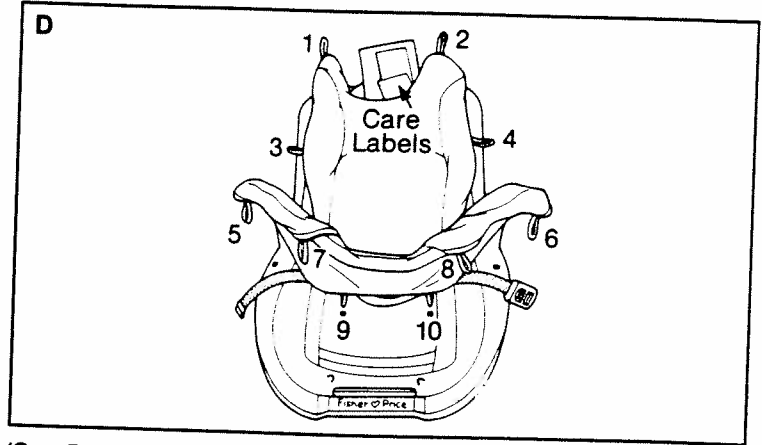

(See FIG. D)

- Turn the seat face up.
- Place the seat pad onto the seat, making sure the care labels are at the top.
- Note the positions of the 10 elastic loops.

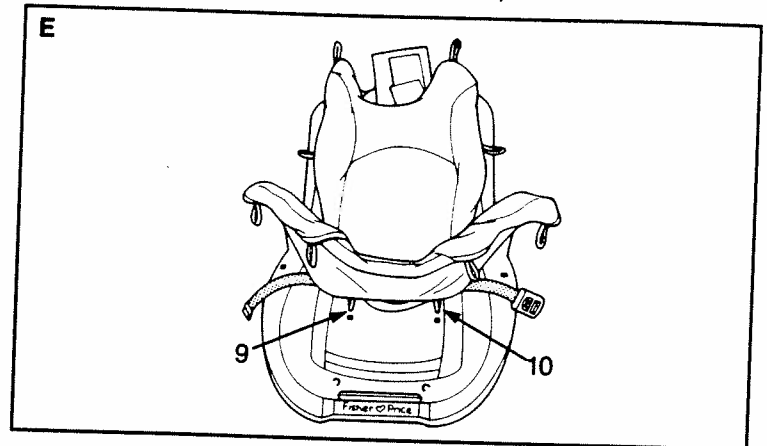

(See FIG. E)

- Lift the seat pad up slightly to insert two elastic loops (9 and 10) through the holes in the seat bottom.
- Turn the seat face down.
- Hook the elastic loops onto the pegs on the back of the seat.

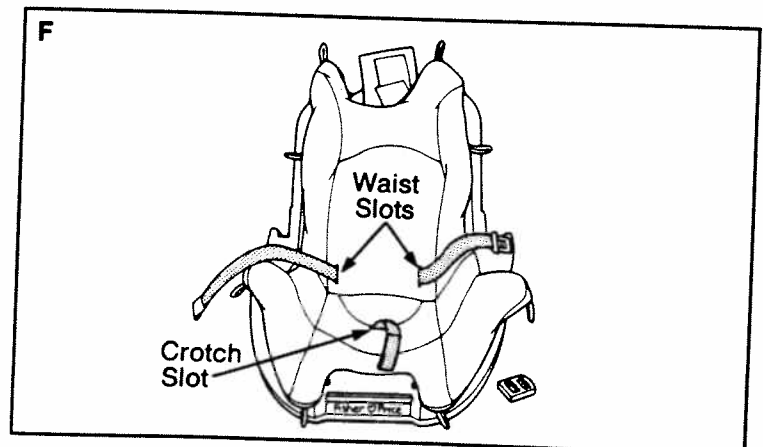

(See FIG. F)

- Remove the buckle from the waist restraint belt by pressing the release button. Set aside the buckle for later assembly (See FIG. H).
- Turn the seat face up.
- Insert the waist restraint belt through the waist slots in the pad.
- Insert the crotch strap through the crotch slot in the pad.

Step 3: Starting Swing

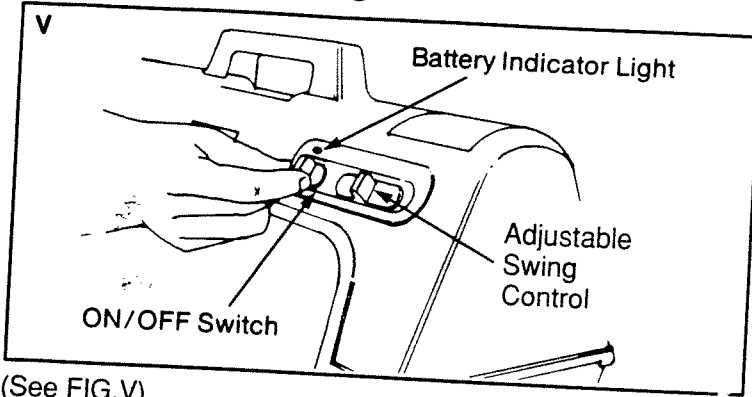

(See FIG. V)

- Set adjustable swing control to the START position.
- Slide ON/OFF switch to ON. The battery indicator light will light.
- To start swinging action, pull the seat forward so the tray goes beyond the front legs.
- Adjust SWING CONTROL for your child's comfort level.
- Always restart swinging action after adjusting swing control by pulling the seat forward so the tray goes beyond the front legs.

NOTE: Using the lowest SWING CONTROL setting will help to extend the life of the batteries.

USE AS AN INFANT SEAT OR ROCKER

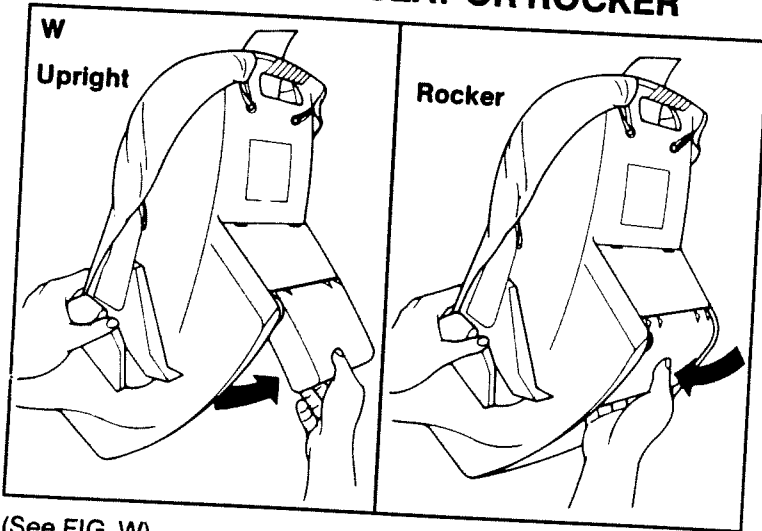

(See FIG. W)

- When the seat is not being used in the swing, it can be used as a portable infant seat.
- The seat rest can be used to adjust the seat into either of two positions: **Upright** or **Rocker**.

Upright

- Remove the seat from the swing.
- Grasp the seat rest and rotate downward.
- Push the seat rest up to lock in position.

Rocker

- Remove the seat from the swing.
- Make sure the seat rest is against the seat bottom.

WARNING:

Never leave child unattended.

To prevent falls: Always use the restraint system.

ROOM-TO-ROOM PORTABILITY

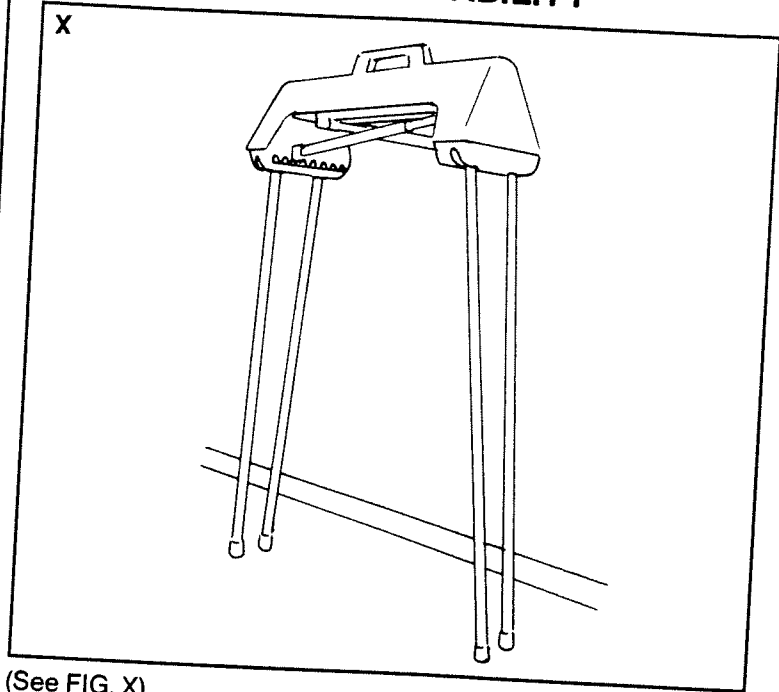

(See FIG. X)

- Remove the seat from the swing.
- Fold arms into swing canopy (see FIG. Z).
- Slide the legs together and lean it against a wall.

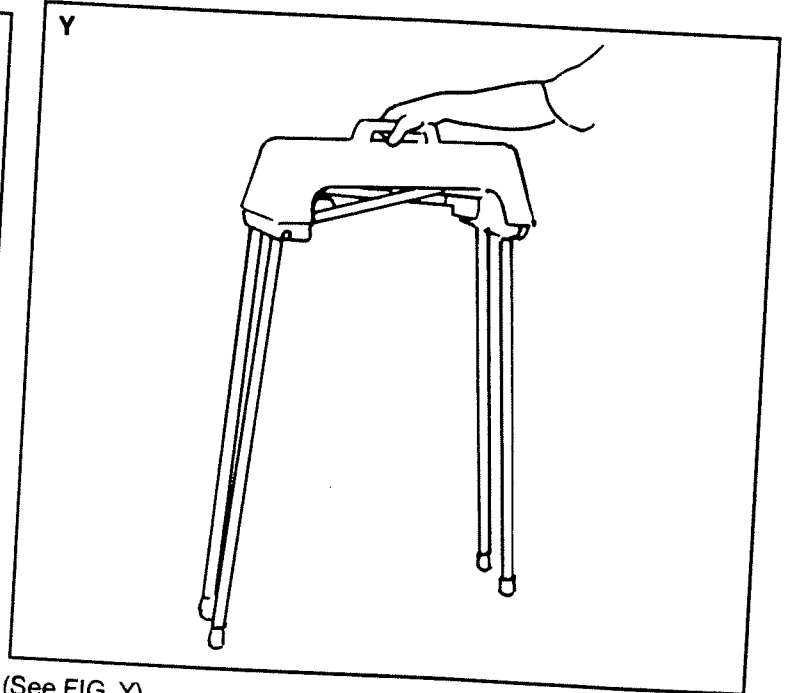

(See FIG. Y)

- Carry the swing as shown, if desired.

WARNING:

Never move swing with child in seat.

NOTE:

Always place swing arms in stored position when seat is removed from swing.

STORAGE

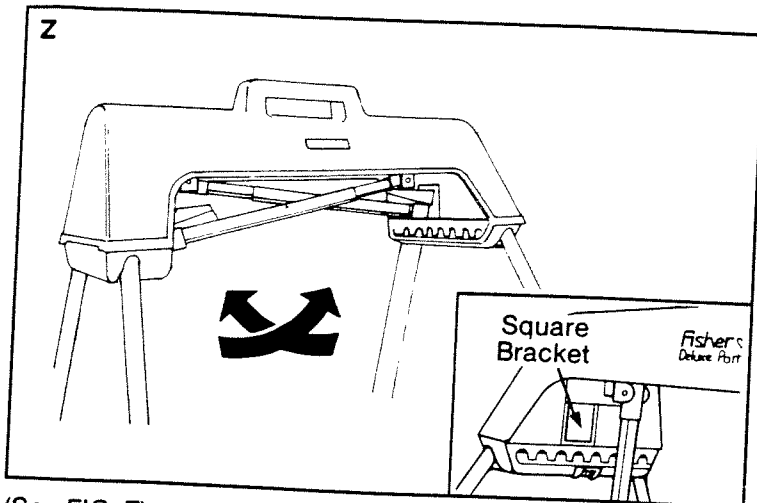

(See FIG. Z)

- Remove seat from swing.
- Grasp swing arms (one at a time) and slide upward, folding them inward as shown.
- Rest the wedges in the square brackets on each side of the swing canopy.
- Remove legs from swing canopy and disassemble. (Do not remove plastic feet.)

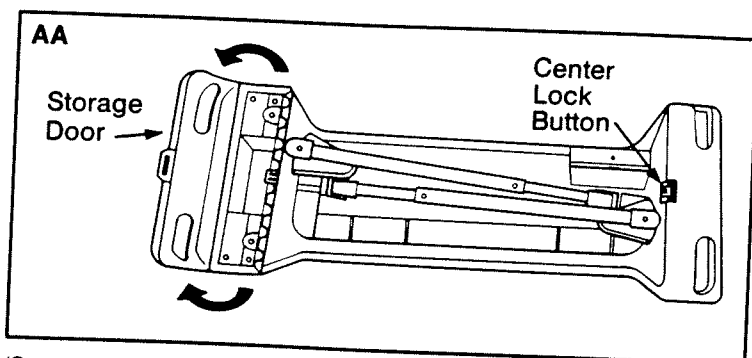

(See FIG. AA)

- Place swing canopy on its back.
- Press center lock button and open storage doors.

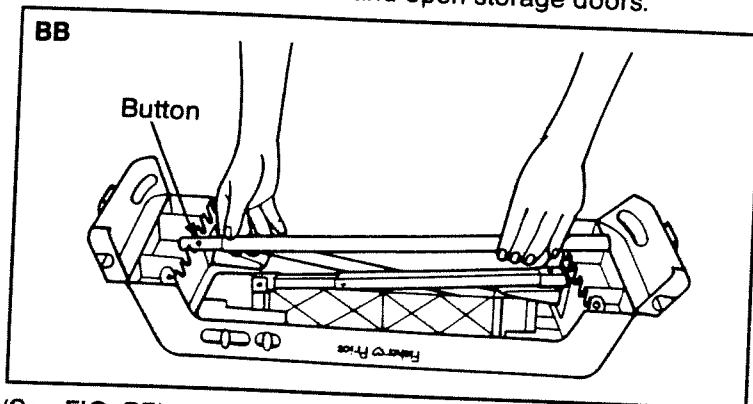

(See FIG. BB)

- There are eight notches on each side of the swing canopy to store the four tapered upper legs and four lower legs.
- On one side, there are four smaller notches (in the center), which are specifically designed to store the tapered upper legs.
- Slide the tapered upper leg (button end first) into the smaller notch on one side and then snap the other end into the corresponding notch on the other side.
- Repeat this procedure to store the other three tapered upper legs.

CC

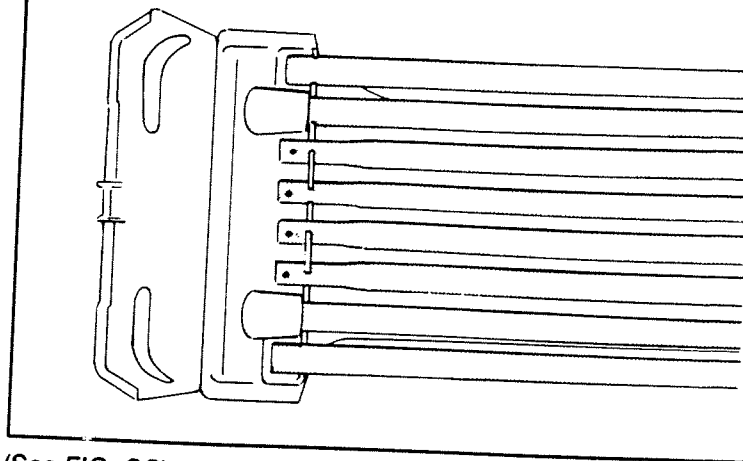

(See FIG. CC)

- Snap the lower legs with feet into the larger notches, alternating them, as shown.

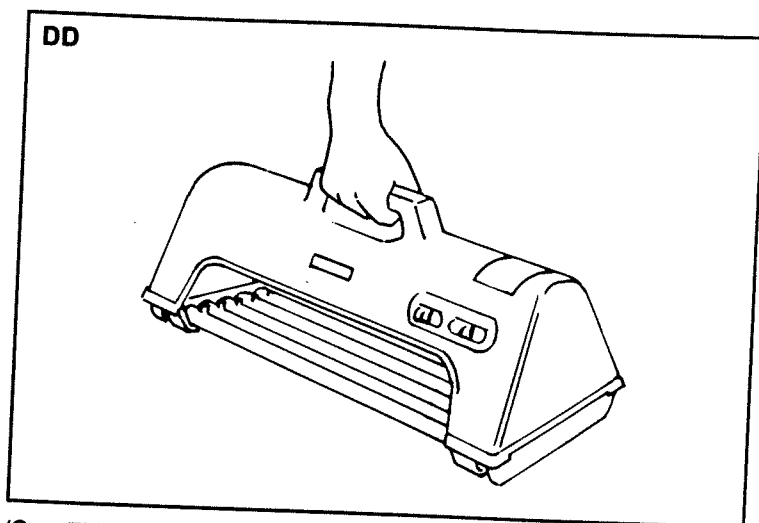

(See FIG. DD)

- Close storage doors and carry, as shown.
- Remove batteries for long-term storage.

CLEANING

- Remove the seat from the swing.
- Unbuckle the waist restraint belts.
- Turn the seat face down and remove the seat pad elastic loops from the pegs, taking note of their position for re-assembly.
- Remove the waist restraint belt and crotch strap from the seat pad.
- Machine wash the seat pad, waist restraint belt and crotch strap in cold water with a mild detergent and tumble dry on low heat. Do not use bleach.
- To clean the seat, tray, swing canopy, and legs, use a mild cleaning agent and damp cloth. Rinse with clean water to remove soap residue.
- Replace the waist restraint belt and crotch strap onto the seat.
- Replace the seat pad onto the seat and insert waist restraint belt and crotch strap.

MAINTENANCE

- Periodically check the Deluxe Port-A-Swing for loose or broken parts.

OWNER'S CHECKLIST

CONDITION	PROBABLE CAUSE	CORRECTION REQUIRED
<ul style="list-style-type: none"> Battery indicator light is not lit; motor is not running. 	<ul style="list-style-type: none"> Power is not on. Battery placement incorrect. Weak batteries. 	<ul style="list-style-type: none"> Slide ON/OFF to ON position. Remove the batteries and replace in correct orientation, as illustrated in the battery compartment. Replace both batteries with new ALKALINE batteries.
<ul style="list-style-type: none"> Battery indicator light is lit; motor is running; swinging stops after a few minutes. 	<ul style="list-style-type: none"> Initial start of swinging action was not sufficient. Swing setting is inappropriate for child's weight. Weak batteries. 	<ul style="list-style-type: none"> To start swinging action, pull seat forward so tray goes beyond front legs. Slide adjustable SWING CONTROL to a different setting and restart swing action. Replace both batteries with new ALKALINE batteries.
<ul style="list-style-type: none"> Battery indicator light is lit, but dim; motor is running; swing stops. 	<ul style="list-style-type: none"> Weak batteries. 	<ul style="list-style-type: none"> Replace both batteries with new ALKALINE batteries.
<ul style="list-style-type: none"> Seat swings crooked. 	<ul style="list-style-type: none"> Seat wedge positions are not the same. 	<ul style="list-style-type: none"> Set both seat wedges to the same position: Recline or Upright.
<ul style="list-style-type: none"> Legs fall off when carrying swing from room to room. 	<ul style="list-style-type: none"> Legs are not correctly connected to the swing canopy. 	<ul style="list-style-type: none"> Make sure each leg has been fully inserted into the slotted socket and onto the wire loop.
<ul style="list-style-type: none"> No difference noticed in swing action when swing control is adjusted. 	<ul style="list-style-type: none"> Swing did not have sufficient time to adjust to different setting. Weak batteries. 	<ul style="list-style-type: none"> Allow the swing time to adjust to new setting. Replace both batteries with new ALKALINE batteries.
<ul style="list-style-type: none"> Audible motor noise and low volume clicking. 	<ul style="list-style-type: none"> Normal operation. 	<ul style="list-style-type: none"> None.

If you have any other questions about the Deluxe Port-A-Swing, please call Fisher-Price Consumer Affairs, toll free at 1-800-432-KIDS (1-800-432-5437) Monday through Friday, between 8 AM and 6 PM Eastern time.

ONE (1) YEAR LIMITED WARRANTY

Fisher-Price, Inc. (636 Girard Avenue, East Aurora, New York 14052) warrants that the Deluxe Port-A-Swing is free from all defects in material and workmanship when used under normal conditions for a period of one (1) year from the date of purchase.

Should the product fail to perform properly, we will repair or replace it at our option, free of charge. Purchaser is responsible for shipping the product to the Fisher-Price Product Service Department at the address indicated above and for all associated freight and insurance cost. Fisher-Price, Inc. will bear the cost of shipping the repaired or replaced item to you. This warranty is void if the owner repairs or modifies the product. This warranty excludes any liability other than that expressly stated above including but not limited to any incidental or consequential damages.

SOME STATES DO NOT ALLOW THE EXCLUSION OR LIMITATION OF INCIDENTAL OR CONSEQUENTIAL DAMAGES, SO THE ABOVE LIMITATION OR EXCLUSION MAY NOT APPLY TO YOU.

THIS WARRANTY GIVES YOU SPECIFIC LEGAL RIGHTS, AND YOU MAY ALSO HAVE OTHER RIGHTS WHICH MAY VARY FROM STATE TO STATE.

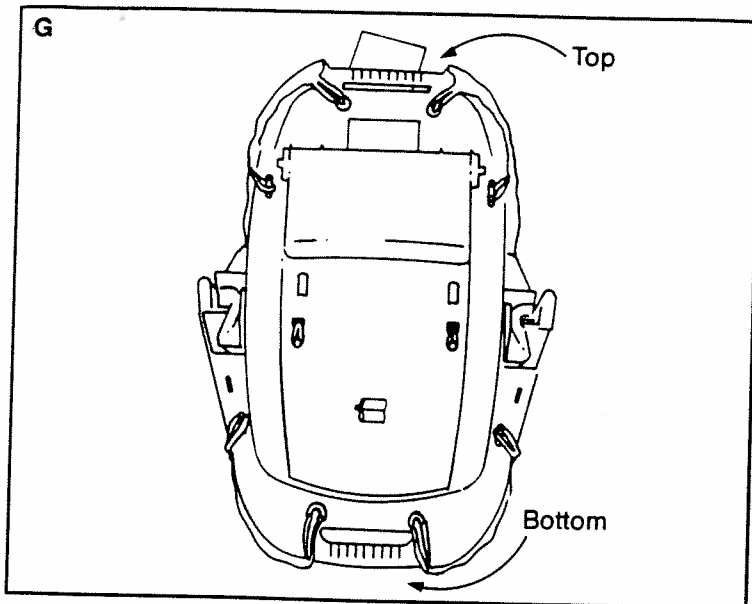

(See FIG. G)

- Turn the seat face down.
- Pull the elastic loops around the top edge (1 and 2) and the bottom edge (7 and 8) and hook them onto the four half circle holes on the back of the seat, as shown.
- Hook the remaining elastic loops (3, 4, 5, 6) onto the pegs on the back of the seat, as shown.

Step 5: Securing The Waist Restraint Belt

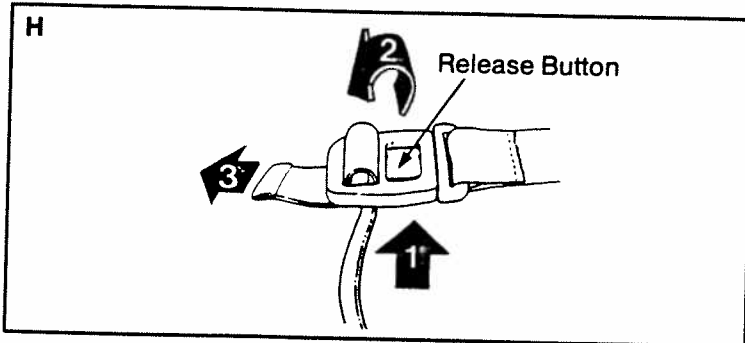

(See FIG. H)

- Insert the release button into the buckle.
 - Hold the buckle with the release button facing up.
- NOTE:** The release button must face up.
- Insert the belt through the slot closest to the release button.
 - Insert the belt through the second slot, as shown.
 - Pull the free end of the belt to adjust.

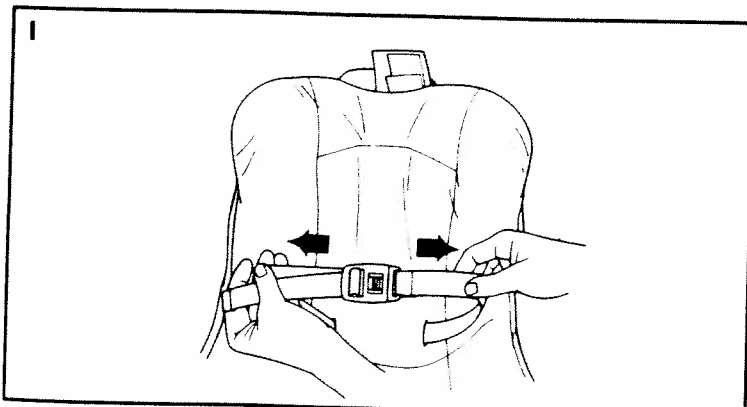

(See FIG. I)

- Pull the belt on both sides of the buckle to be sure the belt does not move.
- If the belt moves, repeat the instructions in FIG. H.

Step 6: Battery Installation

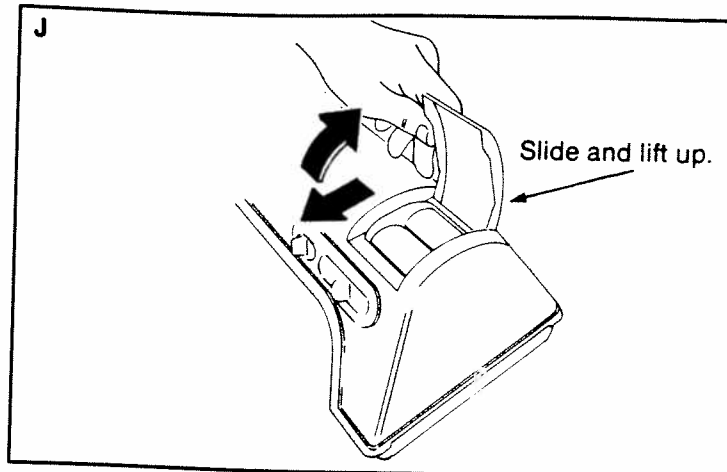

(See FIG. J)

- The battery compartment is located on the swing canopy.
- To open battery compartment, slide lid toward you and lift up.
- Insert two "D" size alkaline batteries, as illustrated inside the battery compartment.
- Close battery compartment lid.

NOTE: Remove batteries during long periods of non-use. Never leave worn-out batteries in the Deluxe Port-A-Swing. Battery leakage and corrosion can damage the unit.

Assembly is now complete.

SET-UP

Step 1: Legs

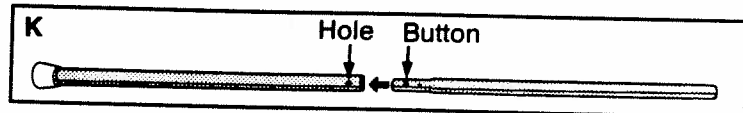

(See FIG. K)

- Press the button on the upper leg and insert it (tapered end) into the lower leg with foot. Make sure the button on the upper leg locks into the hole on the lower leg.
- Repeat this procedure to attach the other three upper legs to the three lower legs.

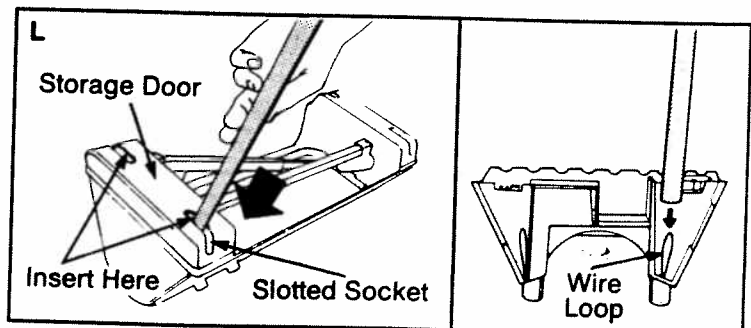

(See FIG. L)

- Make sure storage doors are closed and latched on swing canopy.
- Locate the wire loop in each slotted socket.
- With swing canopy on its back, insert a leg through a slotted socket and onto the wire loop. (There is a slotted socket and wire loop in each corner.)
- Push the leg in until it reaches the bottom of the socket.
- Repeat this procedure with the other three legs.

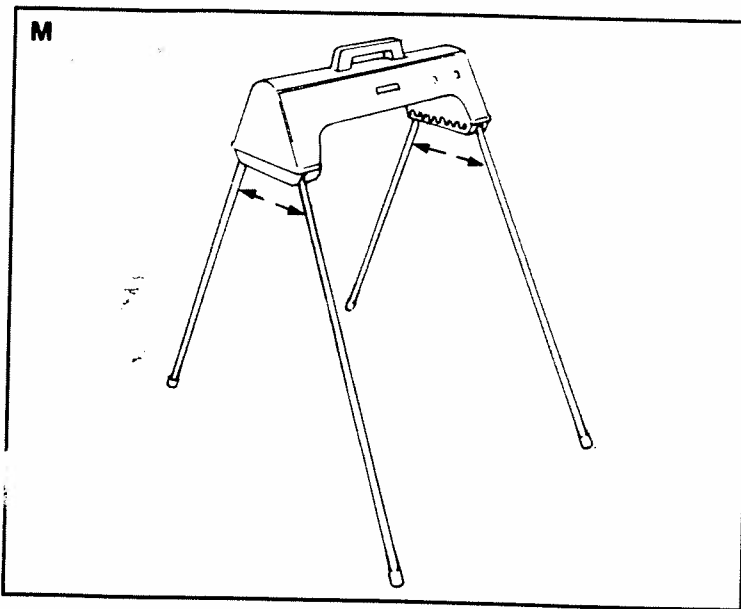

(See FIG. M)

- Stand the swing up on a level surface.
- Using force, move the legs outward until they snap into position to provide a stable platform.

Step 2: Unfold Swing Arms

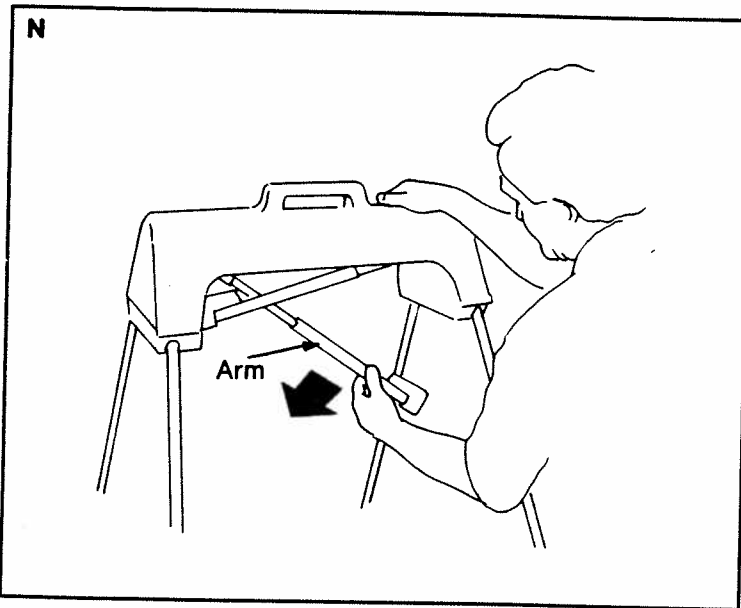

(See FIG. N)

- Push the left arm in and then rotate it down.
- Pull the arm down to fully extend it.
- Repeat this procedure with the right arm.

Step 3: Adjusting The Seat Position For Swinging

Your Fisher-Price Deluxe Port-A-Swing has two seat positions for swinging: **Recline** and **Upright**.

You must select a seat position before placing your child in the seat.

IMPORTANT NOTE:

Never change seat positions with child in seat.

To Adjust To Upright Position:

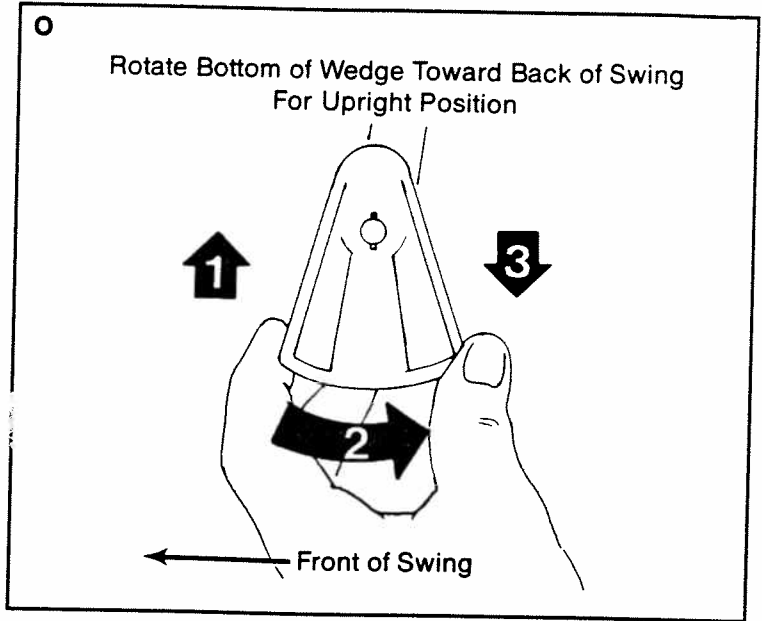

(See FIG. O)

- Locate the wedges on the swing arms.
- Push the wedge up until you hear a "click".
- Rotate the bottom of the wedge toward back of swing.
- Push the wedge down until you hear a "click".
- Repeat this procedure to adjust the other wedge.

To Adjust To Recline Position:

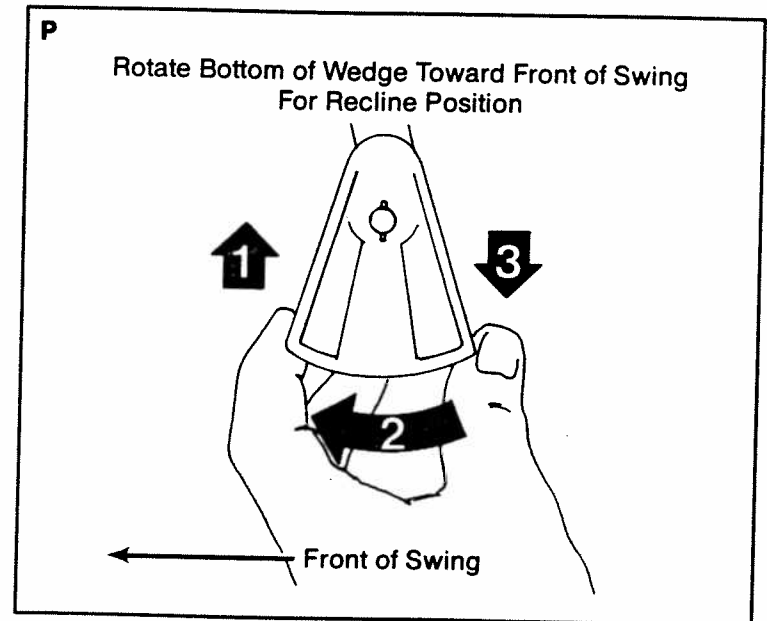

(See FIG. P)

- Locate the wedges on the swing arms.
- Push the wedge up until you hear a "click".
- Rotate the bottom of the wedge toward front of swing.
- Push the wedge down, until you hear a "click".
- Repeat this procedure to adjust the other wedge.

NOTE:

Make sure both right and left wedges are locked in the same position (either **Recline** or **Upright**).

If the wedges are not in the same position, the seat will swing crooked.

Step 4: Placing Seat In Swing

NOTE: Before placing the seat into the swing, make sure desired seat position is selected (Recline or Upright).

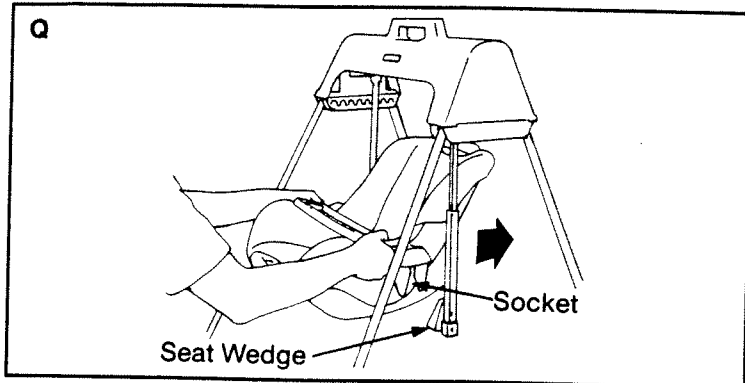

(See FIG. Q)

- Grasp seat and tip it slightly backward.
- Guide the seat between the swing arms and slightly higher than the wedges.

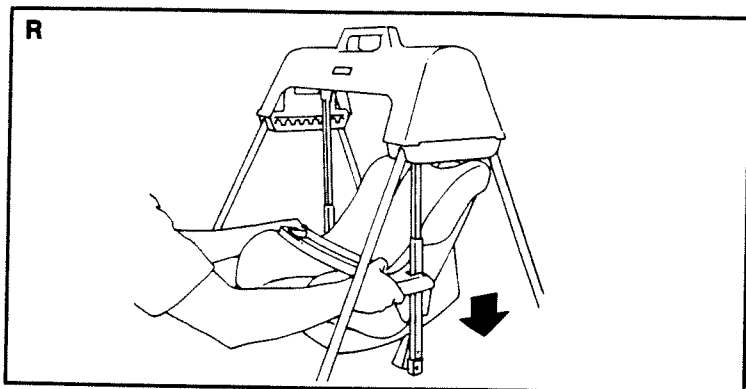

(See FIG. R)

- Tilt the seat forward.
- Slowly lower seat so sockets on seat slide over the wedges.
- Check to be sure that **both wedges** are in the sockets, by pushing down on the seat.

WARNING:
Always remove child before attaching or detaching seat from swing.

Step 5: To Remove Seat

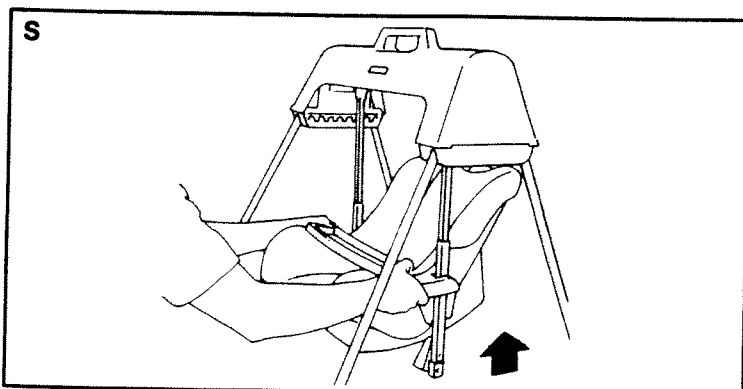

(See FIG. S)

- Grasp seat as shown and lift upward off wedges.
- Tilt the seat backward.
- Pull seat forward and away from swing arms.

USE

Step 1: Securing Child

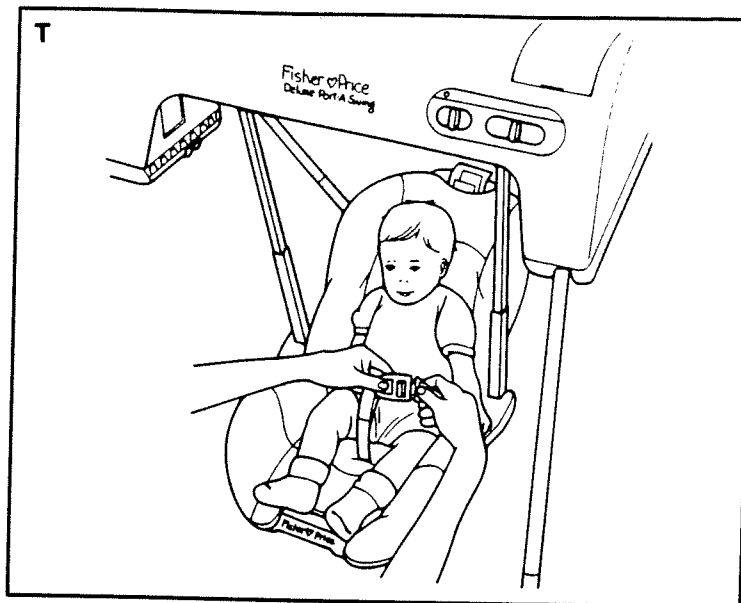

(See FIG. T)

- Place child in seat.
- Insert one end of the waist restraint belt through the crotch strap loop.
- Fasten the waist restraint belts together. **Make sure you hear a click!**
- Pull up on the free end of the belt to tighten for a snug fit.

WARNING:
To prevent falls: Always use the restraint system.

Step 2: Tray Attachment

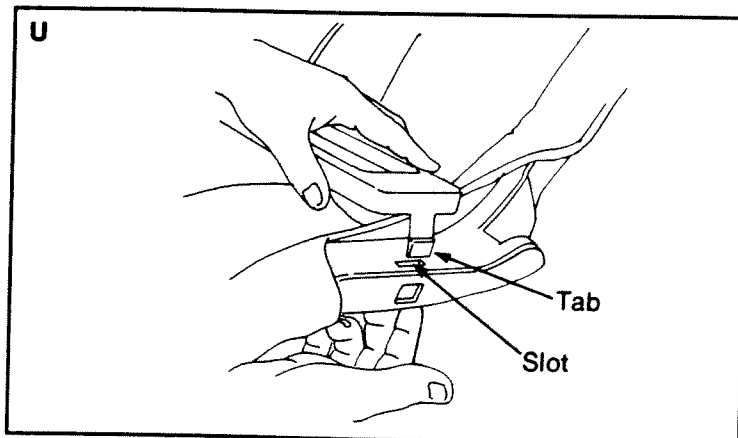

(See FIG. U)

- Insert the plastic tabs on tray sides into the slots on the armrests of the seat.
- Snap tray into place.
- To remove tray, press tabs and lift up.

CAUTION:
Do not lift the seat by the tray.
Use the carrying handles on the seat.