

Fisher-Price®

G9158, J6113
Instructions

Enchanted Motion Musical Gym™

Please keep this instruction sheet for future reference, as it contains important information.

Requires four "C" (LR14) **alkaline** batteries (not included).

Adult assembly is required.

Tool required for battery installation:
Phillips screwdriver (not included).



1 Overhead Play



2 Tummy-Time Play



www.fisher-price.com

⚠ WARNING

To prevent entanglement injury, NEVER place gym or suspend links in a crib or playpen.
NEVER add strings, ties or other products to gym.

Parts

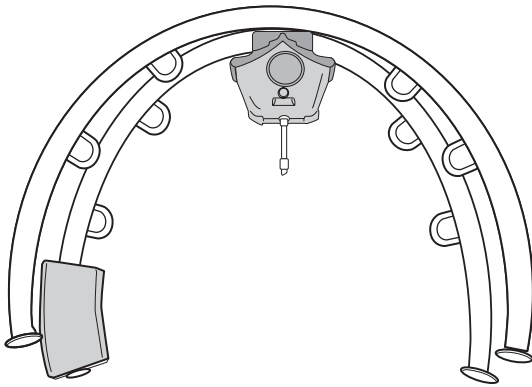

Arch Assembly

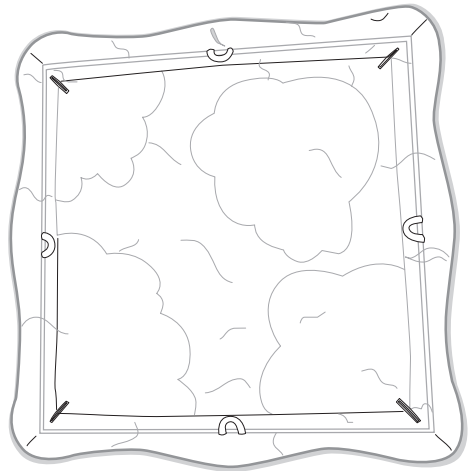

Play Mat

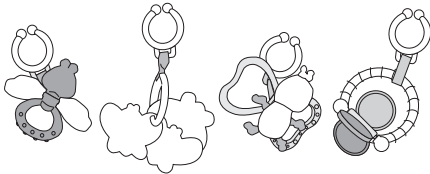

4 Hanging Toys



Bird

Part not shown: Storage Bag

Battery Installation

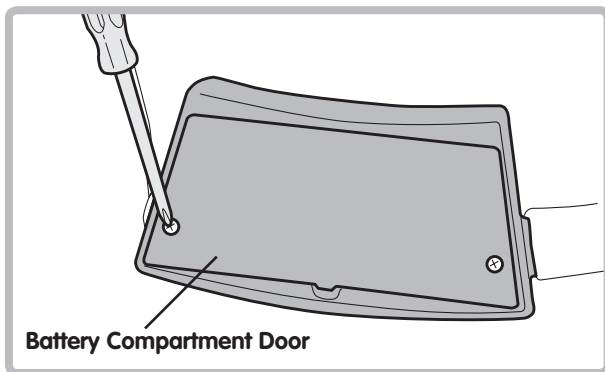
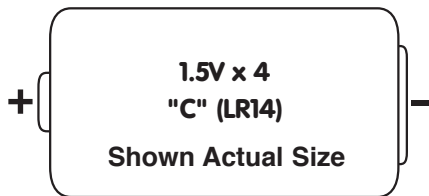

- Locate the battery compartment on the arch assembly.
- Loosen the screws in the battery compartment door with a Phillips screwdriver. Remove the battery compartment door.
- Insert four "C" (LR14) **alkaline** batteries.

Hint: We recommend using **alkaline** batteries for longer life.

- Replace the battery compartment door and tighten the screws with a Phillips screwdriver. Do not over-tighten.
- When lights, sounds or motions from this toy become faint or stop, it's time for an adult to change the batteries!

Battery Safety Information

In exceptional circumstances, batteries may leak fluids that can cause a chemical burn injury or ruin your product. To avoid battery leakage:

- Do not mix old and new batteries or batteries of different types: alkaline, standard (carbon-zinc) or rechargeable (nickel-cadmium).
- Insert batteries as indicated inside the battery compartment.
- Remove batteries during long periods of non-use. Always remove exhausted batteries from the product. Dispose of batteries safely. Do not dispose of this product in a fire. The batteries inside may explode or leak.
- Never short-circuit the battery terminals.
- Use only batteries of the same or equivalent type, as recommended.
- Do not charge non-rechargeable batteries.
- Remove rechargeable batteries from the product before charging.
- If removable, rechargeable batteries are used, they are only to be charged under adult supervision.

Assembly

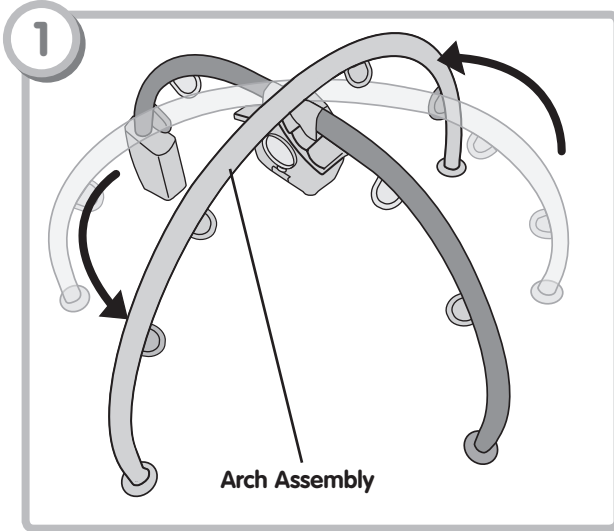

- Grasp one of the soft tubes on the arch assembly and turn the tube, as shown to unfold the toy.

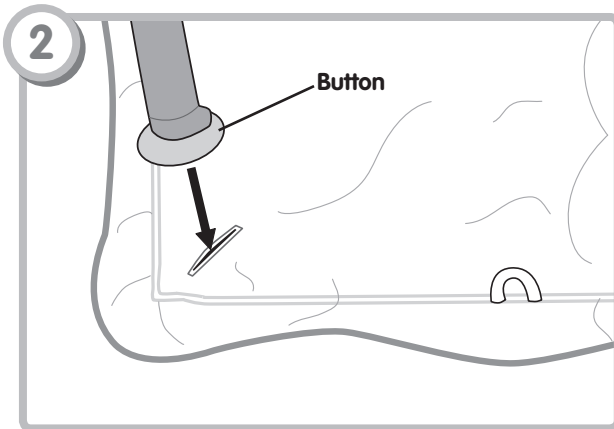

- Place the play mat, print side up, under the arch assembly.
- Fit the "buttons" on the end of each of the four tubes through the slots in the corners of the play mat.

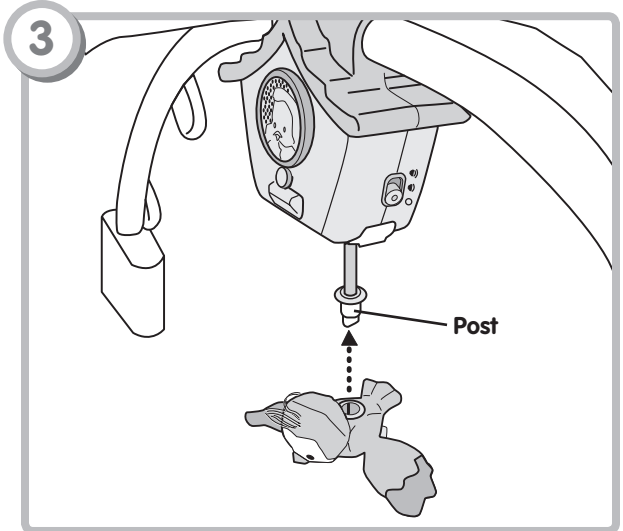

- "Snap" the bird onto the post under the birdhouse, as shown.
- Pull down on the bird to be sure it is secure.

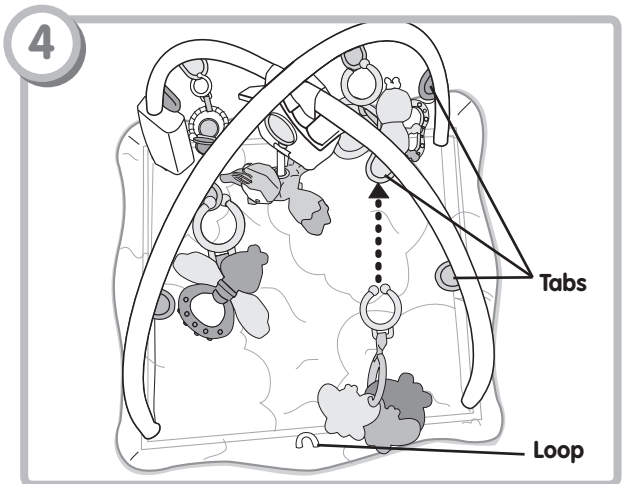

- Attach the toys to any of the tabs on the arch assembly or to any loop on the play mat.



Fluttering Motion, Music and Lights



**Start
Button**

**Power/
Volume
Switch**

Power/Volume Switch

- Locate the power/volume switch on the side of the birdhouse. Slide the switch to: on with low volume  or on with high volume .
- Slide the power/volume switch to the off position  when not in use.

Start Button

- Locate the start button on the front of the birdhouse. Press the start button for extended music, motion and fun sounds.
- Music plays continuously for about 10 minutes with on and off motion.
- To restart, press the start button again, or baby can bat the toys to activate music, motion and sound effects.

Storage

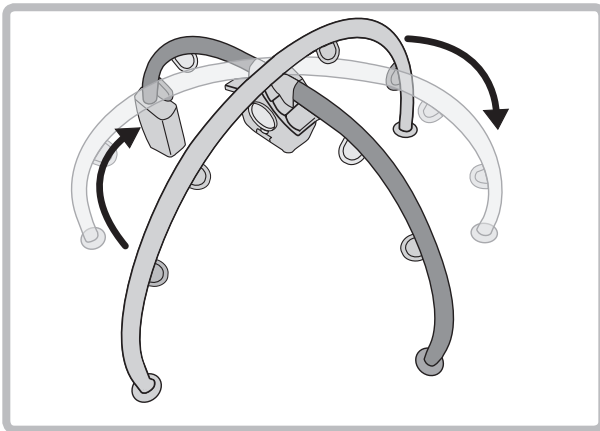

- Remove the hanging toys from the arch assembly.
- Remove the play mat from the arch assembly.
- Grasp one of the soft tubes on the arch assembly and turn the tube, as shown to fold up the toy.
- Place the arch assembly, play mat and hanging toys in the storage bag provided.

Care

Play Mat

- Remove the play mat from the arch assembly.
- Wash the play mat in cold water on a gentle cycle. Do not use bleach. Line dry the play mat.

Hanging Toys and Arch Assembly

- Wipe the surface with a clean cloth dampened with a mild soap and water solution.
- Do not immerse the arch assembly.

For countries outside the United States:

CANADA: Questions? 1-800-432-5437. Mattel Canada Inc., 6155 Freemont Blvd., Mississauga, Ontario L5R 3W2. www.service.mattel.com

GREAT BRITAIN: Mattel UK Ltd, Vanwall Business Park, Maidenhead SL6 4UB. Helpline: 01628 500303; www.service.mattel.com/uk.

AUSTRALIA: Mattel Australia Pty. Ltd., 658 Church Street, Locked Bag #870, Richmond, Victoria 3121 Australia. Consumer Advisory Service 1300 135 312.

NEW ZEALAND: 16-18 William Pickering Drive, Albany 1331, Auckland.

ASIA: Mattel East Asia Ltd, Room 1106, South Tower, World Finance Centre, Harbour City, Tsimshatsui, HK, China.

Consumer Information

Visit us on-line at www.service.fisher-price.com

Call Fisher-Price® Consumer Relations, toll-free at **1-800-432-5437**, 8 AM - 6 PM EST Monday through Friday. Hearing-impaired consumers using TTY/TDD equipment, please call 1-800-382-7470.

Write to us at: Fisher-Price® Consumer Relations, 636 Girard Avenue, East Aurora, New York 14052.

FCC Statement (United States Only)

This equipment has been tested and found to comply with the limits for a Class B digital device, pursuant to Part 15 of the FCC Rules. These limits are designed to provide reasonable protection against harmful interference in a residential installation. This equipment generates, uses and can radiate radio frequency energy and, if not installed and used in accordance with the instructions, may cause harmful interference to radio communications. However, there is no guarantee that interference will not occur in a particular installation. If this equipment does cause harmful interference to radio or television reception, which can be determined by turning the equipment off and on, the user is encouraged to try to correct the interference by one or more of the following measures:

- Reorient or relocate the receiving antenna.
- Increase the separation between the equipment and receiver.
- Consult the dealer or an experienced radio/TV technician for help.

Note: Changes or modifications not expressly approved by the manufacturer responsible for compliance could void the user's authority to operate the equipment.