

hotspot

by



Urban Fire Pit 650/880 Item # 60451/60452

Instructions for Use, Maintenance and Assembly

Distributed by: Well Traveled Living, P. O. Box 4, Amelia Island, FL 32035

Tel: 866-985-7877 Email: cservice@welltraveled.net

Website: www.wtliving.com

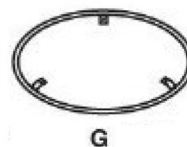
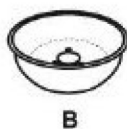
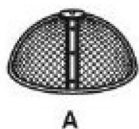
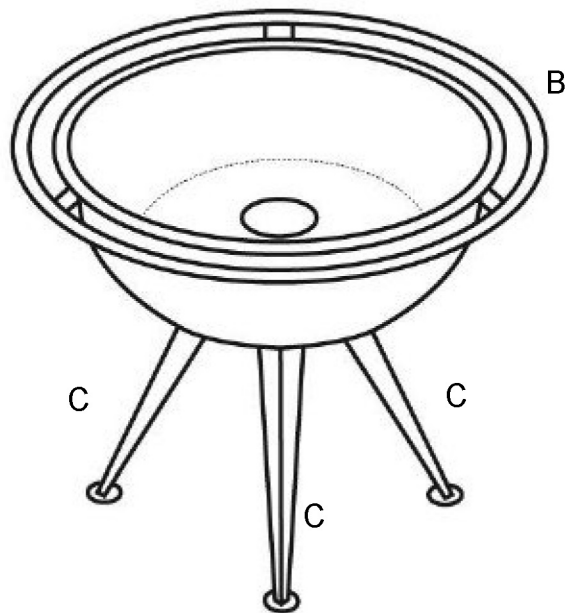
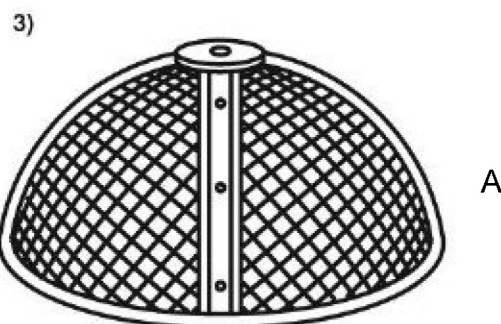
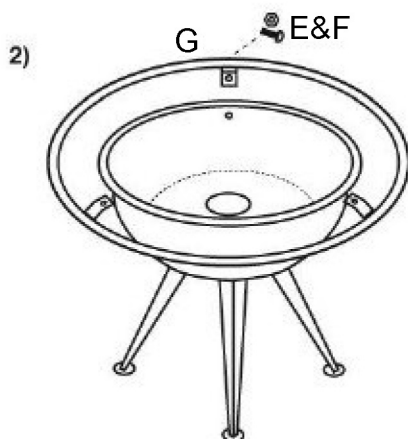
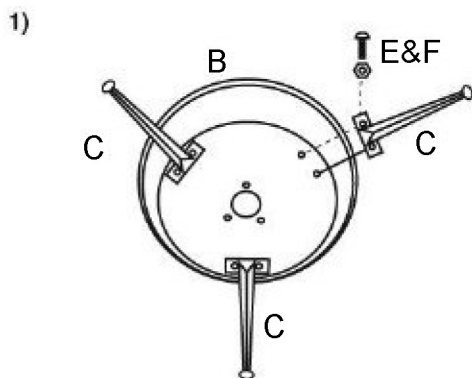

A

B

C

D

E

F

G

1 INTRODUCTION

- Use only in a well ventilated area.
- This appliance must only be used outdoors.
- Do not use under canopies or awnings.
- Do not move the appliance while it is in use.
- For spare parts and servicing contact your supplier or Well Traveled Living.

2 PACKING

The fire pit is supplied in one carton containing the following ready-to-assemble parts:

- A Cover (1)
- B Fire Bowl (1)
- C Leg (3)
- D Hook (1)
- E Screw (9)
- F Nut (9)
- G Guard Rail (1)

3 ASSEMBLY

To avoid scratching, please assemble on a soft surface.

- 1 Use screws (E) and nuts (F) to assemble the legs (C) to the bottom of the fire bowl (B).
- 2 Use screws (E) and nuts (F) to assemble the guard rail circle onto the edge of the fire bowl (B).
- 3 Place the cover(A) on top of the assembled fire pit.

READ THE INSTRUCTIONS BEFORE USE.

Distributed by:
Well Traveled Living
P. O. Box 4
Amelia Island, FL 32035
Tel: 866-985-7877
Fax: 904-261-6769
email: cservice@welltraveled.net
www.wtliving.com

Safety Instructions

For your safety:

- 1 Read the assembly instructions carefully. See exploded view and parts list.
- 2 Place the fire pit on a hard and flat surface prior to use.
- 3 Do not use indoors or under a shelter.
- 4 Do not use the fire pit close to flammable materials.
- 5 **CAUTION!** Do not use alcohol, gasoline or comparable fluids for lighting or re-lighting! Only use fire lighters available in stores.
- 6 Keep the fire lighters away from children.
- 7 **ATTENTION!** This fire pit will become very hot. Do not move it during operation.
- 8 **WARNING!** Keep children and pets away.
- 9 Do not overfill the bowl of your fire pit. It should only be filled to a maximum of 70% of its capacity with charcoal briquettes or wood.
- 10 How to light the fire pit:

Place the fire lighter in the middle of the bowl and add charcoal or wood on top of the fire lighter in a pyramid shape. Ignite the fire lighter with a stick lighter.
- 11 After use of the fire pit, clean the fire pit and all tools.
- 12 * **ATTENTION!** This fire pit will become very hot. Do not move it during operation.

*Do not use indoors!

***CAUTION!** Do not use alcohol, gasoline or comparable fluids for lighting or re-lighting!

***WARNING!** Keep children and pets away.

CAUTION!

- 1 Fire pits release a strong heat and for this reason must be placed on a non-flammable surface.
- 2 Wait until the charcoal or wood is completely put out before moving the fire pit.
- 3 Keep these instructions in a safe place to refer to them whenever needed.

Distributed By:

Well Traveled Living
716 S 8th Street

Amelia Island, FL 32034

Toll Free: 866-WTL-SUPP



Web: www.wtliving.com

Email: cservice@welltraveled.net

1 YEAR LIMITED WARRANTY – Customers in the Continental US

All components are warranted for a period of 1 year after date of purchase by the original owner against defects in materials and workmanship under normal use. This warranty does NOT cover normal wear and weathering, assembly and/or maintenance OR use in a commercial application. At Well Traveled Living's sole discretion, products under warranty will be repaired and/or replaced at no charge to the customer. Any returns sent back to Well Traveled Living must be sent via prepaid freight and in the original retail packaging.

For warranty service contact Well Traveled Living at the address, phone numbers or internet site and email listed in this owner's manual. Be sure to have your sales receipt, date of purchase and catalogue/model numbers available when calling. All warranty service will be coordinated by the Well Traveled Living's, Amelia Island, Florida service center.

This warranty is extended only to the original purchaser. Proof of purchase will be required before warranty service is rendered. The sales receipt is the only valid proof of purchase. This warranty only covers failures due to defects in materials or workmanship which occur during normal use. Failures and/or damage which result from accident, negligence, misuse, abuse, neglect, mishandling, alteration or modification, failure to maintain, improper assembly or maintenance, service by unauthorized agency or use of unauthorized components or damage that is attributable to acts of God are NOT covered.

THERE ARE NO EXPRESS WARRANTIES EXCEPT AS LISTED ABOVE

PURCHASER ASSUMES ALL RISKS IN THE ASSEMBLY AND OPERATION OF THIS UNIT

FAILURE TO FOLLOW WARNINGS AND OPERATIONAL INSTRUCTIONS CONTAINED IN THIS MANUAL CAN RESULT IN SEVERE PROPERTY DAMAGE AND/OR PERSONAL INJURY

IN NO EVENT WILL WELL TRAVELED LIVING, OR ITS DIRECTORS, OFFICERS OR AGENTS BE LIABLE TO THE PURCHASER OR ANY THIRD PARTY, WHETHER IN CONTRACT, IN TORT, OR ON ANY OTHER BASIS, FOR ANY INDIRECT, SPECIAL, PUNITIVE, EXEMPLARY, CONSEQUENTIAL, OR INCIDENTAL LOSS, COST, OR DAMAGE ARISING OUT OF OR IN CONNECTION WITH THE SALE, MAINTENANCE, USE, OR INABILITY TO USE THE PRODUCT, EVEN IF WELL TRAVELED LIVING OR ITS DIRECTORS, OFFICERS OR AGENTS HAVE BEEN ADVISED OF THE POSSIBILITY OF SUCH LOSSES, COSTS OR DAMAGES, OR IF SUCH LOSSES, COSTS, OR DAMAGES ARE FORESEEABLE. IN NO EVENT WILL WELL TRAVELED LIVING, OR ITS OFFICERS, DIRECTORS, OR AGENTS BE LIABLE FOR ANY DIRECT LOSSES, COSTS OR DAMAGES THAT EXCEED THE PURCHASE PRICE OF THE PRODUCT.

SOME JURISDICTIONS DO NOT ALLOW THE EXCLUSION OR LIMITATION OF INCIDENTAL OR CONSEQUENTIAL DAMAGES, SO THE ABOVE LIMITATION OR EXCLUSION MAY NOT APPLY TO THE PURCHASER.

This limited warranty gives you specific legal rights and you may also have other rights which vary from jurisdiction to jurisdiction. The provisions of the United Nations Convention on Contracts for the Sales of Goods shall not apply to this limited warranty or the sale of products covered by this limited warranty.

*****IMPORTANT NOTICE*****

-Do NOT return to place of purchase-
For customer service and warranty issues
contact our Customer Service Center at:

(866)-985-7877 OR

Email: cservice@welltraveled.net

Customer Service Hours: Mon. – Fri. 9:00 a.m. – 6:00 p.m. (EST)