

# ILLUSTRATED PARTS

AMERICAN  AMERICAN  
M A D E O W N E D  
OUTDOOR POWER EQUIPMENT

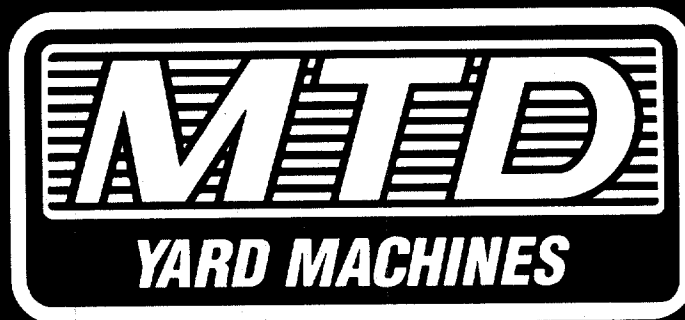

## 1995

## SHREDDERS

Model Number	Pages	Model Number	Pages
245-641A000 .....	2, 3	245-648D000 .....	8, 9
245-642D000 .....	8, 9	245-649C000 .....	6, 7
245-643C000 .....	6, 7	245-650B000 .....	4, 5
245-645A000 .....	2, 3	245-650C000 .....	6, 7
245-645B000 .....	4, 5	245-651B000 .....	4, 5
245-645C000 .....	6, 7	245-653B000 .....	4, 5
245-647C000 .....	6, 7		
245-648B000 .....	4, 5	290-002-000.....	10
245-648C000 .....	6, 7	290-003-000.....	10

# Models 641A and 645A

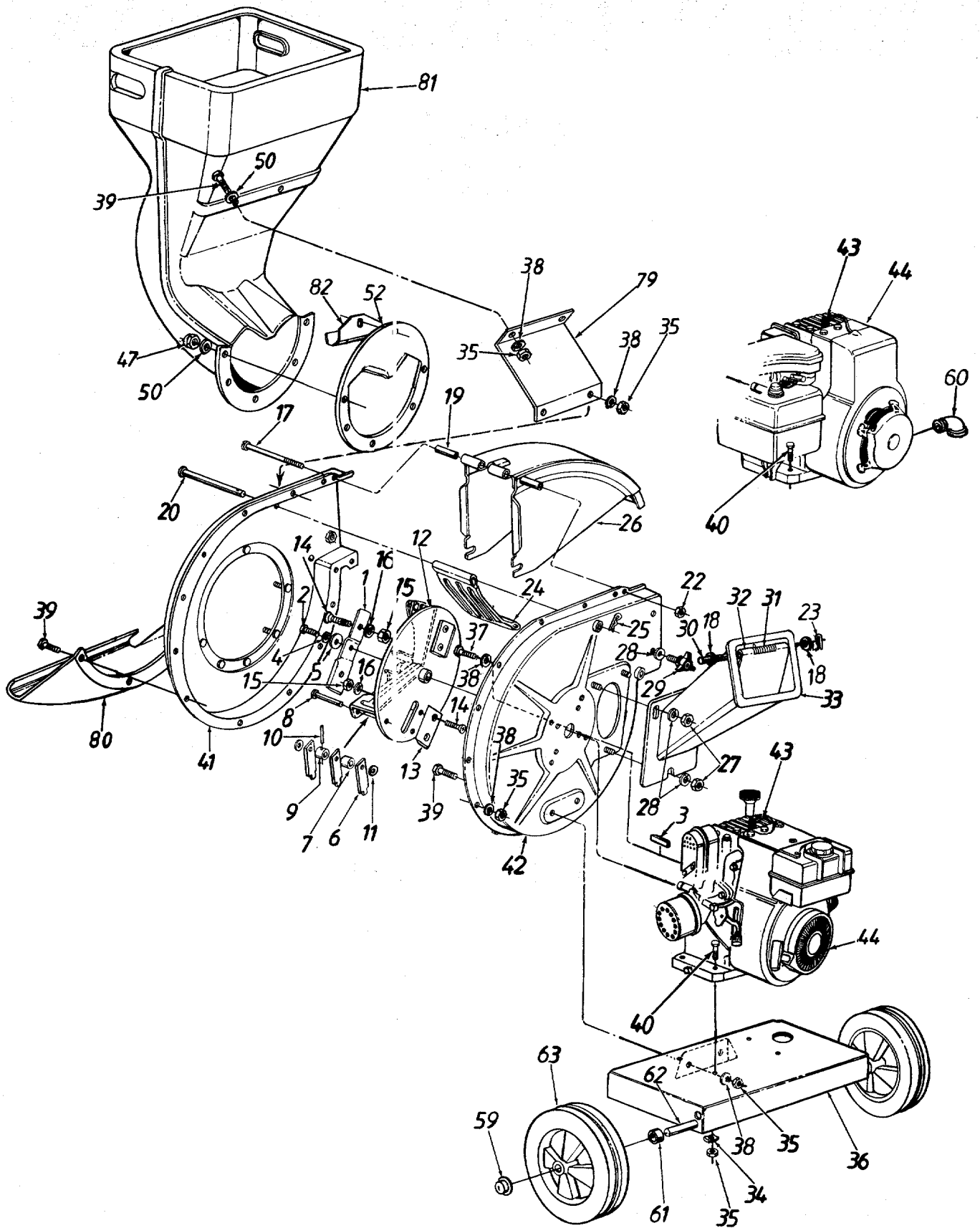

# Models 641A and 645A

## PARTS LIST FOR SHREDDERS

REF. NO.	PART NO.	CODE	DESCRIPTION	REF. NO.	PART NO.	CODE	DESCRIPTION
1	742-0571		Blade	28	736-0242		Bell-Wash. .345" I.D. x .88"
2	710-0818		Hex Patch Bolt 3/8-24 x 2" Lg. (Gr. 8)†	29	720-0170		Hand Knob
	710-1254		Hex Patch Bolt 3/8-24 x 2.25" (Gr. 8)††	30	747-0744A		Chipper Door Rod
3	714-0114		Sq. Key 1/4 x 2.0" Lg.†	31	732-0542		Torsion Spring 1.14" Lg.
4	736-0217		L-Wash. 3/8" I.D. H.D.	32	781-0489		Chipper Door
5	736-0247		Fl-Wash. .406" I.D. x 1.25" O.D. Hdn.	33	781-0475		Chipper Chute Ass'y.
6	11459B		Flail	34	736-0170		Spec. L-Wash. 5/16" I.D.
7	711-0564		Flail Spacer	35	712-3010		Hex Nut 5/16-18 Thd. (Gr. 5)
8	711-0833A		Clevis Pin .496" Dia.	36	781-0510A		Shredder Frame
9	711-0834		Flail Spacer w/.160" Dia. Hole	37	710-0157		Hex Bolt 5/16-24 x .75" Lg.
10	715-0249		Spring Roll Pin 1.12" Lg.	38	736-0119		L-Wash. 5/16" I.D.*
11	736-0192		Fl-Wash. .531" I.D. x .94" O.D.	39	710-3008		Hex Bolt 5/16-18 x .75" Lg. (Gr. 5)
12	681-0002		Impeller Ass'y. Comp.†	40	710-0442		Hex Bolt 5/16-18 x 1.5" Lg.*
	681-0030		Impeller Ass'y. Comp.†† (Incl. Ref. 1, 6, 7, 8, 9, 10, 11, 12, 13, 14)	41	681-0004		Flail Housing Ass'y.—L.H.
				42	781-0474A		Flail Housing Ass'y.—R.H.
				43	735-0639		Spark Plug Boot
				44	—		Engine
13	781-0490		Chipper Blade	47	712-0429		Elastic Lock Nut 5/16-18 Thd.
14	710-1054		Flat Hd. Scr. 5/16-24 x .75" Lg.	50	736-0264		Fl-Wash. 5/16" I.D.
15	712-0411		Hex Top L-Nut 5/16-24 (Gr. 5)	52	781-0521		Back-Up Plate
16	736-0119		L-Wash. 5/16" I.D.*	59	726-0214		Push Cap 5/8" Dia. Rod
17	710-0825		Hex Bolt 1/4-20 x 3.75" Lg.*	60	737-0195		Drain Elbow (5 HP B&S)
18	736-0142		Fl-Wash. .281" I.D. x .50" O.D.	61	750-0786		Spacer .64" I.D. x .38" Lg.
19	750-0793		Chute Hinge Spacer 1.66" Lg.	62	738-0814		Shredder Axle
20	711-0835		Clevis Pin .5" Dia. x 4.62" Lg.	63	734-1603		Wheel Ass'y. Comp.
22	712-0291		Hex Ctr. L-Nut 1/4-20 Thd.*	79	781-0519		Hopper Support Brkt.
23	714-3010		Cotter Pin	80	781-0515		Front Support Brkt.
24	781-0457		Shredder Screen	81	731-1307		Leaf Hopper
25	714-0149B		Internal Cotter Pin 3/8" Dia.	82	781-0589		Hopper Shield
26	781-0480		Chute Deflector Ass'y.	—	764-0199A		Bag (Not Shown)
27	712-3010		Hex Nut 5/16-18 Thd. (Gr. 5)	—	723-0400		Safety Glasses (Not Shown)

†Used with Keyed Engine Crankshaft.

††Used with Tapered Engine Crankshaft.

\*For faster service obtain standard nuts, bolts and washers locally.  
If these items cannot be obtained locally, order by part number  
and size as shown on parts list.

# Models 645B, 648B, 650B, 651B and 653B

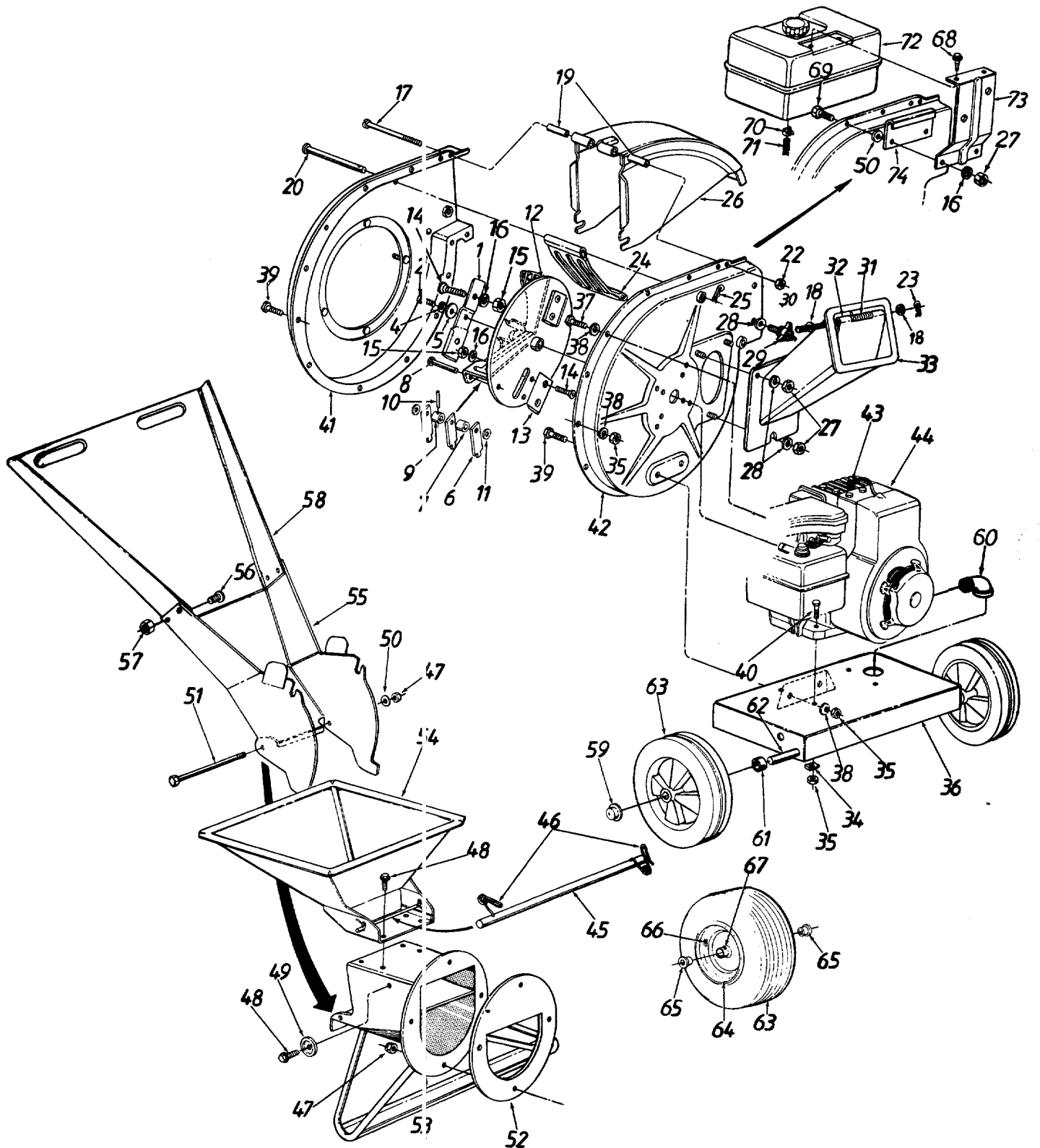

# Models 645B, 648B, 650B, 651B and 653B

## PARTS LIST FOR SHREDDERS

REF. NO.	PART NO.	CODE	DESCRIPTION	REF. NO.	PART NO.	CODE	DESCRIPTION
1	742-0571		Blade	41	681-0004		Flail Housing Ass'y.—L.H.
2	710-1254		Hex Patch Bolt 3/8-24 x 2.25" (Gr. 8)	42	781-0474A		Flail Housing Ass'y.—R.H.
4	736-0217		L-Wash. 3/8" I.D. H.D.	43	735-0639		Spark Plug Boot (Optional)
5	736-0247		Fl-Wash. .406" I.D. x 1.25" O.D. Hdn.	44	—		Engine
6	11459B		Flail	45	747-0531A		Release Bar
7	711-0564		Flail Spacer	46	732-0546		Torsion Spring 1.06" Lg.
8	711-0833A		Clevis Pin .496" Dia.	47	712-0429		Elastic Lock Nut 5/16-18 Thd.
9	711-0834		Flail Spacer w/.160" Dia. Hole	48	710-0601		Hex Wash. Hd. Self-Tap Scr. 5/16-18 x .75" Lg.
10	715-0249		Spring Roll Pin 1.12" Lg.	49	11480		Stop Washer
11	736-0192		Fl-Wash. .531" I.D. x .94" O.D.	50	736-0264		Fl-Wash. 5/16" I.D.
12	681-0030		Impeller Ass'y. Comp. (Incl. Ref. 1, 6, 7, 8, 9, 10, 11, 12, 13, 14)	51	710-0542		Hex Bolt 5/16-18 x 8.38" Lg.
13	781-0490		Chipper Blade	52	781-0487B		Back-Up Plate
14	710-1054		Flat Hd. Scr. 5/16-24 x .75" Lg.	53	16522B		Inlet Guide Ass'y.
15	712-0411		Hex Top L-Nut 5/16-24 (Gr. 5)	54	11481B		Hopper Ass'y.
16	736-0119		L-Wash. 5/16" I.D.*	55	781-0509		Lower Leaf Ramp Section
17	710-0825		Hex Bolt 1/4-20 x 3.75" Lg.*	56	710-0286		Truss Mach. Scr. 1/4-20 x .5**
18	736-0142		Fl-Wash. .281" I.D. x .5" O.D.	57	712-0107		Hex L-Nut 1/4-20 Thd.
19	750-0793		Chute Hinge Spacer 1.66" Lg.	58	11461B		Upper Leaf Ramp Section
20	711-0835		Clevis Pin .5" Dia. x 4.62" Lg.	59	726-0214		Push Cap 5/8" Dia. Rod
22	712-0291		Hex Ctr. L-Nut 1/4-20 Thd.*	60	737-0195		Drain Elbow (5 HP B&S)
23	714-3010		Cotter Pin 3/32" x 5/8"		737-0125		Drain Elbow (8 HP B&S)
24	781-0457		Shredder Screen	61	750-0786		Spacer .64" I.D. x .38" Lg.
25	714-0149B		Internal Cotter Pin 3/8" Dia.	62	738-0814		Shredder Axle†
26	781-0480		Chute Deflector Ass'y.		738-0813		Shredder Axle††
27	712-3010		Hex Nut 5/16-18 Thd. (Gr. 5)	63	734-1600		Wheel Ass'y. Comp. (Plastic— 10 x 2.5)
28	736-0242		Bell-Wash. .345" I.D. x .88"		734-1597		Wheel Ass'y. Comp. (Steel— 10 x 4)
29	720-0170		Hand Knob	64	734-1598		Tire Only††
30	747-0744A		Chipper Door Rod	65	734-1455		Rim Only††
31	732-0542		Torsion Spring 1.14" Lg.	66	741-0487		Flange Bearing .632" I.D.††
32	781-0489		Chipper Door	67	734-0255		Air Valve††
33	781-0475		Chipper Chute Ass'y.	68	737-0280		Grease Fitting††
34	736-0170		Spec. L-Wash. 5/16" I.D.	68	710-0895		Hex Hi-Low Scr. 1/4 x .75" (650, 651)
35	712-3010		Hex Nut 5/16-18 Thd. (Gr. 5)	69	710-3038		Hex Bolt 5/16-18 x .88" Lg. (650, 651)
36	781-0510A		Shredder Frame (645, 648)	70	726-0205		Hose Clamp (650, 651)
	781-0459A		Shredder Frame (650, 651, 653)	71	751-0535-7		Fuel Line—7 in. (650, 651)
37	710-0157		Hex Bolt 5/16-24 x .75" Lg.	72	751-0570		Fuel Tank Ass'y. Comp. (650, 651)
38	736-0119		L-Wash. 5/16" I.D.*	73	781-0497		Fuel Tank Mtg. Brkt. (650, 651)
39	710-3008		Hex Bolt 5/16-18 x .75" Lg. (Gr. 5)	74	781-0498		Fuel Tank Support Brkt. (650, 651)
40	710-0442		Hex Bolt 5/16-18 x 1.5" Lg. (5 H.P. & 8 H.P. Tec.)	—	764-0199A		Bag (Not Shown)
	710-0380		Hex Bolt 5/16-18 x 1.75" Lg. (8 H.P.)*	—	723-0400		Safety Glasses (Not Shown)

†Used with 10 x 2.5 Wheel (Plastic—Part No. 734-1600).  
††Used with 10 x 4 Wheel (Steel—Part No. 734-1597).

\*For faster service obtain standard nuts, bolts and washers locally.  
If these items cannot be obtained locally, order by part number  
and size as shown on parts list.

# Models 643C, 645C, 647C, 648C, 649C and 650C

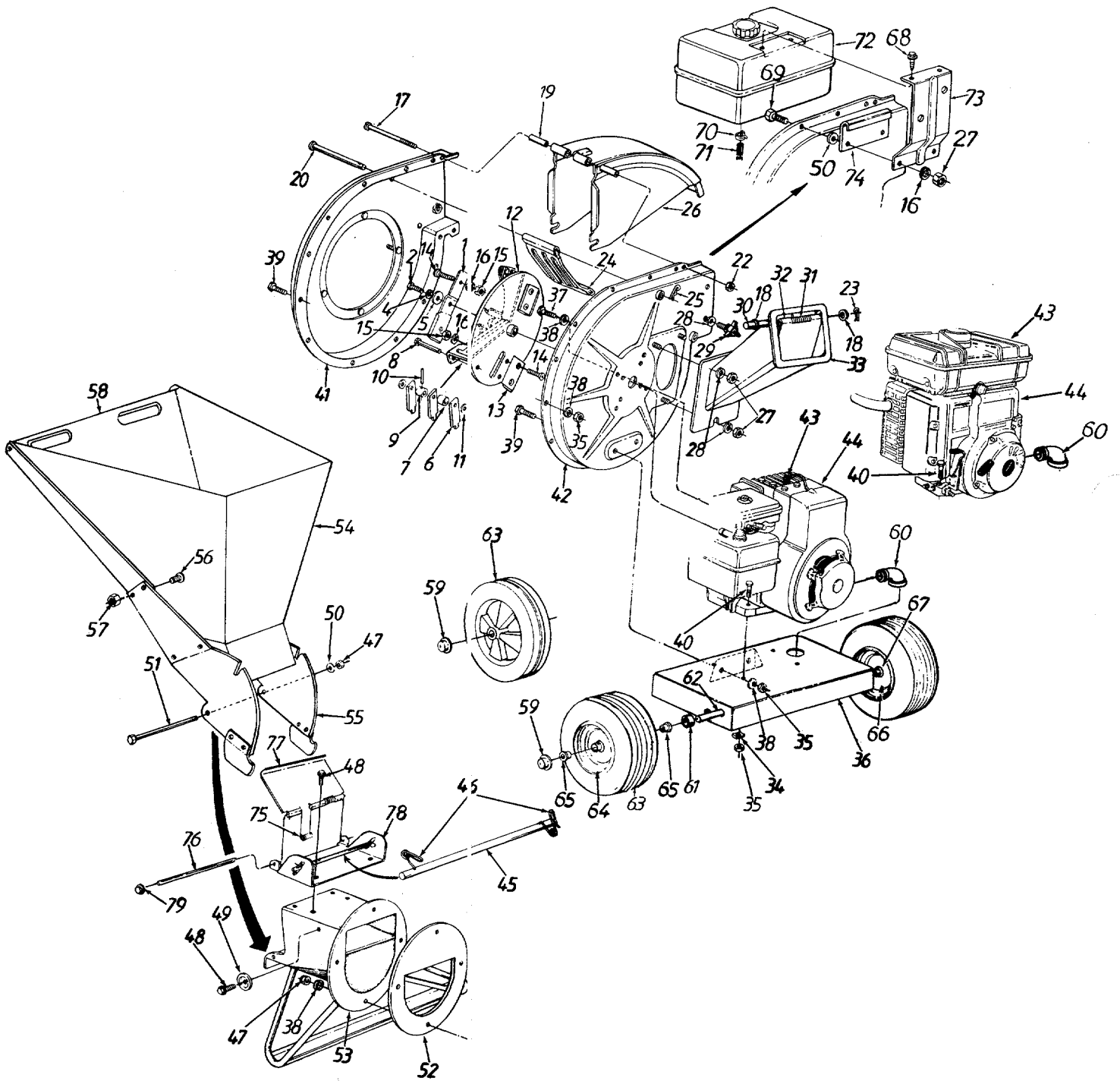

# Models 643C, 645C, 647C, 648C, 649C and 650C

## PARTS LIST FOR SHREDDERS

REF. NO.	PART NO.	CODE	DESCRIPTION	REF. NO.	PART NO.	CODE	DESCRIPTION
1	742-0571		Blade	43	735-0639		Spark Plug Boot (Optional)
2	710-1254		Hex Patch Bolt 3/8-24 x 2.25" (Gr. 8)	44	—		Engine
4	736-0217		L-Wash. 3/8" I.D. H.D.	45	747-0531A		Release Bar
5	736-0247		Fl-Wash. .406" I.D. x 1.25" O.D. Hdn.	46	732-0546		Torsion Spring 1.06" Lg.
6	11459B		Flail	47	712-0429		Elastic Lock Nut 5/16-18 Thd.
7	711-0564		Flail Spacer	48	710-0601		Hex Wash. Hd. Self-Tap Scr. 5/16-18 x .75" Lg.
8	711-0833A		Clevis Pin .496" Dia.	49	11480		Stop Washer
9	711-0834		Flail Spacer w/.160" Dia. Hole	50	736-0264		Fl-Wash. 5/16" I.D.
10	715-0249		Spring Roll Pin 1.12" Lg.	51	710-0542		Hex Bolt 5/16-18 x 8.38" Lg.
11	736-0192		Fl-Wash. .531" I.D. x .94" O.D.	52	781-0487B		Back-Up Plate
12	681-0030		Impeller Ass'y. Comp. (Incl. Ref. 1, 6, 7, 8, 9, 10, 11, 12, 13, 14)	53	16522B		Inlet Guide Ass'y.
13	742-0490		Chipper Blade	54	781-0494		Pivot Hopper Hood
14	710-1054		Flat Hd. Scr. 5/16-24 x .75" Lg.	55	16524B		Upper Guide Ass'y.
15	712-0411		Hex Top L-Nut 5/16-24 (Gr. 5)	56	710-0286		Truss Mach. Scr. 1/4-20 x .5**
16	736-0119		L-Wash. 5/16" I.D.*	57	712-0107		Hex L-Nut 1/4-20 Thd.
17	710-0825		Hex Bolt 1/4-20 x 3.75" Lg.*	58	11461B		Upper Leaf Ramp Section
18	736-0142		Fl-Wash. .281" I.D. x .5" O.D.	59	726-0214		Push Cap 5/8" Dia. Rod
19	750-0793		Chute Hinge Spacer 1.66" lg.	60	737-0195		Drain Elbow (645C & 647C)
20	711-0835		Clevis Pin .5" Dia. x 4.62" Lg.		737-0125		Drain Elbow (650C)
22	712-0291		Hex Ctr. L-Nut 1/4-20 Thd.*	61	750-0786		Spacer .64" I.D. x .38" Lg.
23	714-3010		Cotter Pin	62	738-0814		Shredder Axle (643C & 645C)
24	781-0457		Shredder Screen		738-0813		Shredder Axle†
25	714-0149B		Internal Cotter Pin 3/8" Dia.	63	734-1600		Wheel Ass'y. Comp. (643C & 645C)
26	781-0480		Chute Deflector Ass'y.		734-1597		Wheel Ass'y. Comp.†
27	712-3010		Hex Nut 5/16-18 Thd. (Gr. 5)	64	734-1455A		Rim Only†
28	736-0242		Bell-Wash. .345" I.D. x .88"	65	741-0487A		Flange Bearing .632" I.D.†
29	720-0170		Hand Knob	66	734-0255		Air Valve†
30	747-0744A		Chipper Door Rod	67	737-0211		Grease Fitting†
31	732-0542		Torsion Spring 1.14" Lg.	68	710-0895		Hex Hi-Low Scr. 1/4" x .75" Lg. (650C)
32	781-0489		Chipper Door	69	710-3038		Hex Bolt 5/16-18 x .88" Lg. (650C)
33	781-0475		Chipper Chute Ass'y.	70	726-0205		Hose Clamp (650C)
34	736-0170		Spec. L-Wash. 5/16" I.D.	71	751-0535-7		Fuel Line—7" Lg. (650C)
35	712-3010		Hex Nut 5/16-18 Thd. (Gr. 5)	72	751-0570		Fuel Tank Ass'y. Comp. (650C)
36	781-0510A		Shredder Frame	73	781-0497		Fuel Tank Mtg. Brkt. (650C)
	781-0459A		Shredder Frame (650C Only)	74	781-0498		Fuel Tank Support Brkt. (650C)
37	710-0157		Hex Bolt 5/16-24 x .75" Lg.	75	732-0629		Torsion Spring
38	736-0119		L-Wash. 5/16" I.D.*	76	747-0747		Hopper Door Rod
39	710-3008		Hex Bolt 5/16-18 x .75" Lg. (Gr. 5)	77	781-0492		Hopper-Pivot Door
40	710-0380		Hex Bolt 5/16-18 x 1.75" Lg.*	78	781-0493		Hopper Lockout Brkt.
41	681-0004		Flail Housing Ass'y.—L.H.	79	726-0106		Cap Speed Nut 1/4" Rod
42	781-0474A		Flail Housing Ass'y.—R.H.	—	764-0199A		Bag (Not Shown)
				—	723-0400		Safety Glasses (Not Shown)

†Models 647C, 648C, 649C and 650C

# Models 642D and 648D

## OPTIONAL ACCESSORIES

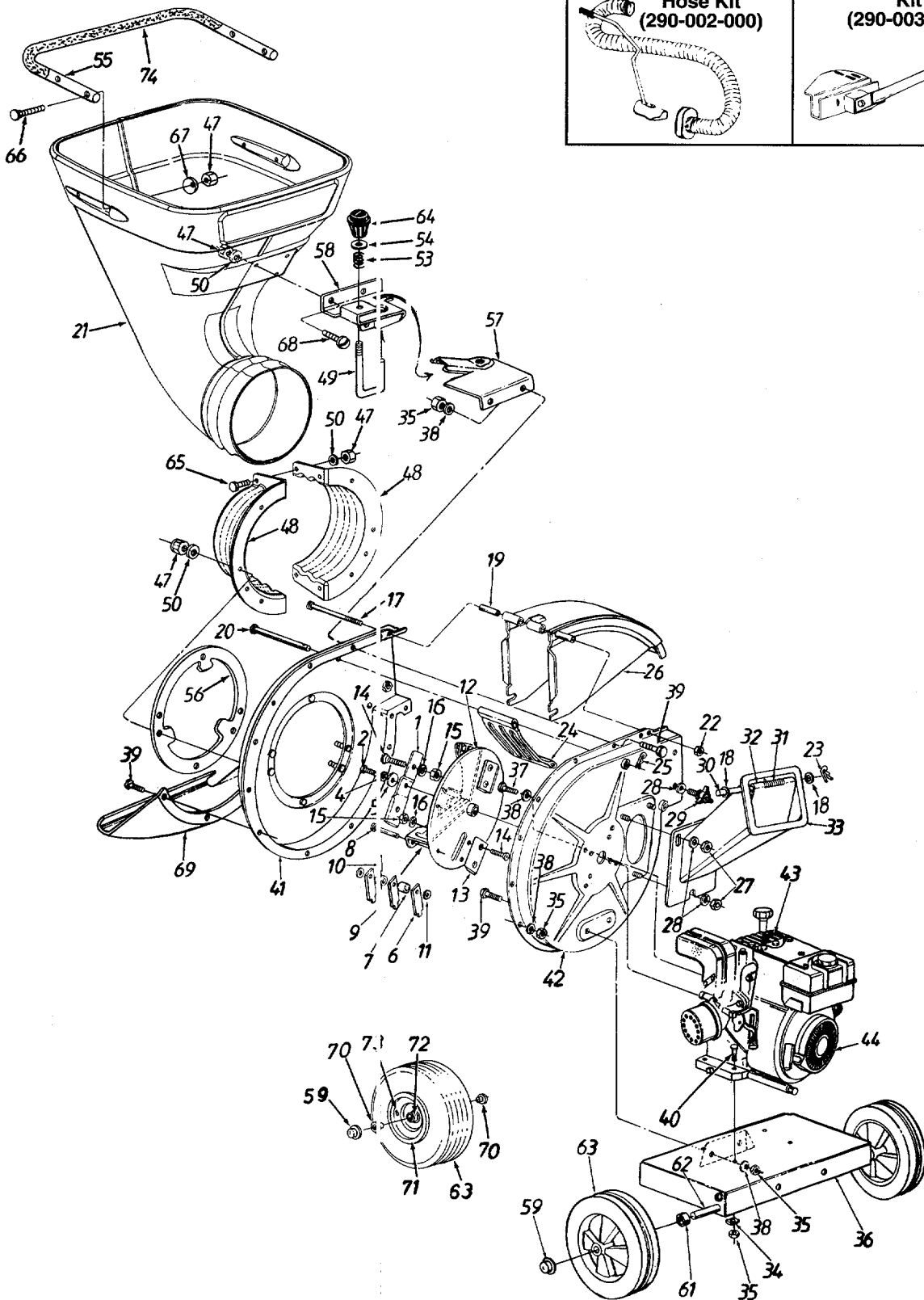
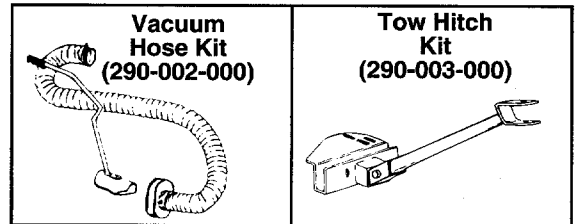



# Models 642D and 648D

## PARTS LIST FOR MODELS 642D AND 648D SHREDDER

REF. NO.	PART NO.	CODE	DESCRIPTION	REF. NO.	PART NO.	CODE	DESCRIPTION
1	742-0571		Blade	38	736-0119		L-Wash. 5/16" I.D.*
2	710-1254		Hex Patch Bolt 3/8-24 x 2.25" Lg.	39	710-3008		Hex Bolt 5/16-18 x .75" Lg. (Gr. 5)
4	736-0217		L-Wash. 3/8" I.D. H.D.	40	710-0442		Hex Bolt 5/16-18 x 1.5" Lg.*
5	736-0247		Fl-Wash. .406" I.D. x 1.25" O.D. Hdn.	41	681-0004		Flail Housing Ass'y.—L.H.
6	11459B		Flail	42	781-0474A		Flail Housing Ass'y.—R.H.
7	711-0564		Flail Spacer	43	735-0639		Spark Plug Boot
8	711-0833A		Clevis Pin .496" Dia.	44	—		Engine
9	711-0834		Flail Spacer w/.160" Dia. Hole	47	712-0429		Elastic Lock Nut 5/16-18 Thd.
10	715-0249		Spring Roll Pin 1.12" Lg.	48	731-1428		Hopper Mtg. Collar
11	736-0192		Fl-Wash. .531" I.D. x .94" O.D.	49	781-0568		Locking Pin
12	681-0030		Impeller Ass'y. Comp.	50	736-0264		Fl-Wash. 5/16" I.D.
13	781-0490		Chipper Blade	53	732-0730		Spring 1.5" Lg.
14	710-1054		Flat Hd. Scr. 5/16-24 x .75" Lg.	54	736-0117		Fl-Wash. .385" I.D. x .62" O.D.
15	712-0411		Hex Top L-Nut 5/16-24 (Gr. 5)	55	749-0932		Handle
16	736-0119		L-Wash. 5/16" I.D.*	56	781-0574		Back-Up Plate
17	710-0825		Hex Bolt 1/4-20 x 3.75" Lg.*	57	781-0562		Lower Locking Brkt.
18	736-0142		Fl-Wash. .281" I.D. x .50" O.D.	58	781-0561		Upper Locking Brkt.
19	750-0793		Chute Hinge Spacer 1.66" Lg.	59	726-0214		Push Cap 5/8" Dia. Rod
20	711-0835		Clevis Pin .5" Dia. x 4.62" Lg.	61	750-0786		Spacer .64" I.D. x .38" Lg.
21	731-1427		Rotating Hopper (642D)	62	738-0814		Shredder Axle (642D)
	731-1512	N	Rotating Hopper (648D)		738-0813		Shredder Axle (648D)
22	712-0291		Hex Ctr. L-Nut 1/4-20 Thd.	63	734-1600		Wheel Ass'y. Comp. (642D)
23	714-3010		Cotter Pin		734-1597		Wheel Ass'y. Comp. (648D)
24	781-0457		Shredder Screen		734-1598		Tire Only (648D)
5	714-0149B		Internal Cotter Pin 3/8" Dia.	64	720-0232		Knob
26	781-0480		Chute Deflector Ass'y.	65	710-0376		Hex Bolt 5/16-18 x 1" Lg. (Gr. 5)
27	712-3010		Hex Nut 5/16-18 Thd. (Gr. 5)	66	710-1267		Curved Carr. Bolt 5/16-18 x 1.25" Lg.
28	736-0242		Bell-Wash. .345" I.D. x .88"	67	736-0451		Saddle Wash. .32" I.D.
29	720-0170		Hand Knob	68	710-0451		Carr. Bolt 5/16-18 x .75" Lg.
30	747-0744A		Chipper Door Rod	69	781-0515		Front Support Brkt.
31	732-0542		Torsion Spring 1.14" Lg.	70	741-0487A		Flange Bearing .632" I.D. (648D)
32	781-0489		Chipper Door	71	734-1455A		Rim Only (648D)
33	781-0475		Chipper Chute Ass'y.	72	737-0211		Grease Fitting (648D)
34	736-0170		Spec. L-Wash. 5/16" I.D.	73	734-0255		Air Valve (648D)
35	712-3010		Hex Nut 5/16-18 Thd. (Gr. 5)	74	720-0280		Foam Grip
36	781-0510A		Shredder Frame	—	764-0199A		Bag (Not Shown)
37	710-0157		Hex Bolt 5/16-24 x .75" Lg.	—	723-0400		Safety Glasses (Not Shown)

\*For faster service obtain standard nuts, bolts and washers locally. If these items cannot be obtained locally, order by part number and size as shown on parts list.

# VACUUM HOSE KIT

## PARTS LIST FOR MODEL 290-002 VACUUM HOSE KIT

**Model Number  
290-002-000**

REF. NO.	PART NO.	QTY.	DESCRIPTION
1	710-0106	1	Hex Bolt 1/4-20 x 1.25" Lg.*
2	710-0258	1	Hex Bolt 1/4-20 x .62" Lg.*
3	712-0291	2	Hex L-Nut 1/4-20 Thd
4	720-0281	1	Grip
5	726-0327	2	Adj. Hose Clamp 5" Dia.
6	731-1462	1	Plug
8	736-0451	1	Saddle Washer .32" I.D. x .937"
9	749-0005	1	Handle
10	764-0455	1	Hose—5" Dia.
11	731-1524	1	Nozzle Tube
12	710-0323	2	Truss Mach. Scr. 5/16-18 x 3/4" Lg.
13	736-3008	4	Fl-Wash. .344" I.D. x .75" O.D.
14	736-0278	6	Fl-Wash. .328" I.D. x .68" O.D.
15	712-0158	2	Hex L-Nut 5/16-18 Thd.

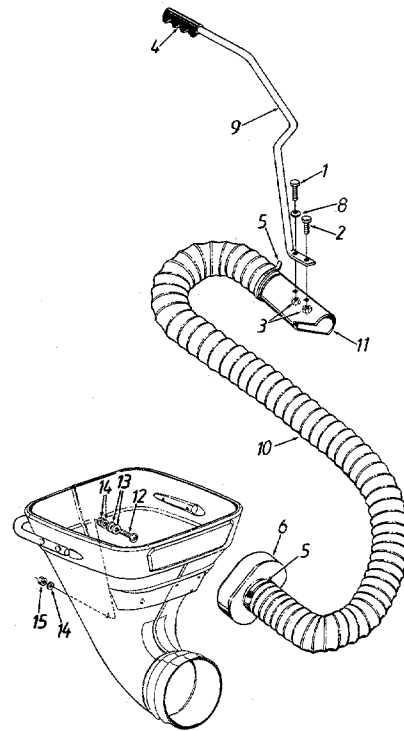

# TOW HITCH KIT

## PARTS LIST FOR MODEL 290-003 TOW HITCH KIT

**Model Number  
290-003-000**

REF. NO.	PART NO.	CODE	DESCRIPTION
1	681-0042		Tow Bar Base
2	681-0043		Tow Bar Tongue
3	710-3001		Hex Bolt 3/8-16 x .88" Lg. (Gr. 5)
4	711-0299		Clevis Pin 2.4" Lg.
5	712-0798		Hex Nut 3/8-16 Thd.*
6	736-0133		Fl-Wash. .406" I.D. x 1.25" O.D. x .10"
7	711-0835		Clevis Pin 4.62" Lg.
8	732-0194		Spring Pin
9	736-0169		L-Wash. 3/8" I.D.*

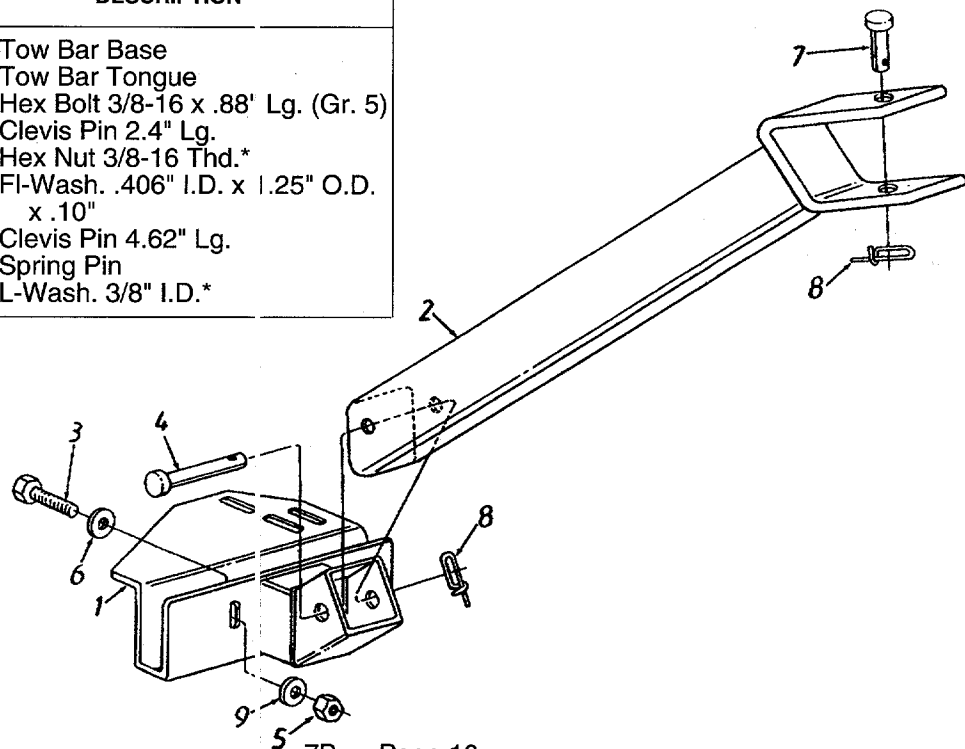

\*For faster service obtain standard nuts, bolts and washers locally. If these items cannot be obtained locally, order by part number and size as shown on parts list.

1

2

3

