

# **EURO-PRO** X<sup>®</sup>

## **TOASTER OVEN**

**Owner's Manual**  
**Model TO279**  
**120V., 60Hz., 1500 Watts**



**USA: EURO-PRO OPERATING LLC**  
94 Main Mill Street, Door 16  
Plattsburg, NY 12901

**Canada: EURO-PRO OPERATING LLC**  
4400 Bois Franc  
St. Laurent, QC H4S 1A7

Tel.: 1 (800) 798-7398  
[www.euro-pro.com](http://www.euro-pro.com)

# IMPORTANT SAFETY INSTRUCTIONS

When using your **Toaster Oven**, basic safety precautions should always be observed, including the following:

1. Read all instructions before using your **Toaster Oven**.
2. **Do not** touch hot surfaces. Always use handles or knobs.
3. Close supervision is necessary when any appliance is used by or near children.
4. To protect against electric shock, **do not** immerse cord, plug or any parts of the oven in water or any other liquids.
5. **Do not** let cord hang over edge of table or counter, or touch hot surfaces.
6. **Do not** operate appliance with damaged cord or plug or after the appliance malfunctions or has been damaged in any manner. Return appliance to the nearest **EURO-PRO Operating LLC** for examination, repair or adjustment.
7. The use of accessory attachments not recommended by the appliance manufacturer may cause hazard or injury.
8. **Do not** place on or near a hot gas or electric burner.
9. When operating the oven, keep at least four inches of free space on all sides of the oven to allow for adequate air circulation.
10. Unplug from outlet when not in use and before cleaning. Allow to cool before putting on or taking off parts, and before cleaning.
11. To disconnect, turn the time control button to OFF, then remove the plug. Always hold the plug, and never pull the cord.
12. Extreme caution must be used when moving a drip pan containing hot oil or other hot liquids.
13. **Do not** cover crumb tray or any part of the oven with metal foil. This may cause the oven to overheat.
14. Use extreme caution when removing the tray, racks or disposing of hot grease or other hot liquids.
15. Do not clean the inside of the oven with metal scouring pads. Pieces can break off the pad and touch electrical parts, creating a risk of electric shock.
16. Oversized foods or metal utensils **must not** be inserted in a toaster oven as they may create a fire or risk of electric shock.
17. A fire may occur if the oven is covered or touching flammable material, including curtains, draperies, walls and the like when in operation. Do not place any items on the oven during operation.
18. Extreme caution should be exercised when using cooking or baking containers constructed of anything other than metal or ovenproof glass.
19. Be sure that nothing touches the top or bottom elements of the oven.
20. **Do not** place any of the following materials in the oven: cardboard, plastic, paper, or anything similar.
21. **Do not** store any materials other than manufacturer's recommended accessories in this oven when not in use.
22. This appliance is **OFF** when the Timer Control button is in the "**OFF**" position.
23. Always wear protective, insulated oven gloves when inserting or removing items from the hot oven.
24. This appliance has a tempered, safety glass door. The glass is stronger than ordinary glass and more resistant to breakage. Tempered glass can still break around the edges. Avoid scratching door surface or nicking edges.
25. **Do not** use outdoors.
26. **Do not** use appliance for other than intended use.

This unit has a short power supply cord to Reduce the risk resulting from becoming entangled in or tripping over a long cord. An extension cord may be used if you are careful in its use:

1. The electrical rating of the extension cord should be at least as great as the electrical rating of the appliance.
2. An extension cord with the power cord must be arranged so that it will not drape over the countertop or tabletop where they can be pulled on by children or tripped over accidentally.

## SAVE THESE INSTRUCTIONS For Household Use Only

**WARNING:** To reduce the risk of electric shock, this appliance has a polarized plug (one blade is wider than the other). This plug will fit in a polarized outlet only one way. If the plug does not fit fully in the outlet, reverse the plug. If it still does not fit, contact a qualified electrician to install the proper outlet. **Do not modify the plug in any way.**

## ONE (1) YEAR LIMITED WARRANTY

**EURO-PRO Operating LLC** warrants this product to be free from defects in material and workmanship for a period of one (1) year from the date of the original purchase, when utilized for normal household use, subject to the following conditions, exclusions and exceptions.

If your appliance fails to operate properly while in use under normal household conditions within the warranty period, return the complete appliance and accessories, freight prepaid to

In U.S.: **EURO-PRO Operating LLC**, 94 Main Mill Street, Door 16, Plattsburg, N.Y. 12901  
In Canada: **EURO-PRO Operating LLC**, 4400 Bois Franc, St. Laurent, Quebec H4S 1A7

If the appliance is found by **EURO-PRO** to be defective in material or workmanship, **EURO-PRO** will repair or replace it free of charge. Proof of purchase date and \$ 16.95 to cover the cost of return shipping and handling must be included. \*

The liability of **EURO-PRO Operating LLC** is limited solely to the cost of the repair or replacement of the unit at our option. This warranty does not cover normal wear of parts and does not apply to any unit that has been tampered with or used for commercial purposes. This limited warranty does not cover damage caused by misuse, abuse, negligent handling or damage due to faulty packaging or mishandling in transit. This warranty does not cover damage or defects caused by or resulting from damages from shipping or repairs, service or alterations to the product or any of its parts, which have been performed by a repair person not authorized by **EURO-PRO**.

This warranty is extended to the original purchaser of the unit and excludes all other legal and/or conventional warranties. The responsibility of **EURO-PRO Operating LLC** if any, is limited to the specific obligations expressly assumed by it under the terms of the limited warranty. **In no event** is **EURO-PRO Operating LLC** liable for incidental or consequential damages of any nature whatsoever. Some states/provinces do not permit the exclusion or limitation of incidental or consequential damages, so the above may not apply to you.

This warranty gives you specific legal rights, and you may also have other rights which vary from state to state or province to province.

**\*Important: Carefully pack item to avoid damage in shipping. Be sure to include proof of purchase date and to attach tag to item before packing with your name, complete address and phone number with a note giving purchase information, model number and what you believe is the problem with item. We recommend you insure the package (as damage in shipping is not covered by your warranty). Mark the outside of your package "ATTENTION CUSTOMER SERVICE". We are constantly striving to improve our products, therefore the specifications contained herein are subject to change without notice.**



## PRODUCT REGISTRATION CARD

### FOR CANADIAN CONSUMERS ONLY

Please complete and return within ten (10) days of purchase. The registration will enable us to contact you in the event a product defect is discovered. By returning this card you acknowledge to have read and understood the instructions for use, and warnings set forth in the accompanying instructions. RETURN TO:

**EURO-PRO Operating LLC, 4400 Bois Franc, St. Laurent, Quebec H4S 1A7**

**TO279**

Appliance Model

Date of Purchase

Name of store

Owner's name

Address

City

Province

Postal Code

Printed in China

9

## GETTING TO KNOW YOUR TOASTER OVEN

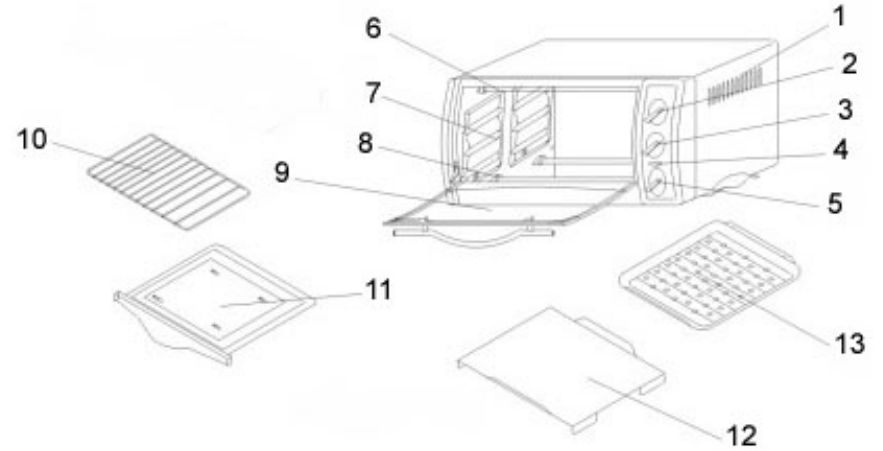

### TEMPERATURE CONTROL

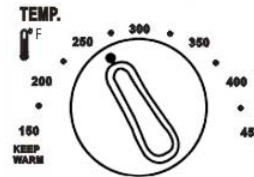

### FUNCTION CONTROL

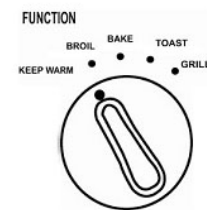

### TIMER

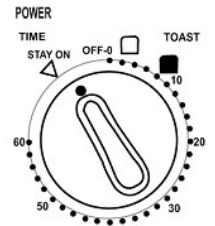

1. Housing
2. Temperature Control
3. Function Control
4. Indicator Light
5. Timer
6. Upper Heating Element
7. Rack Support Guides

8. Lower Heating Element
9. Glass Door
10. Wire Rack (x2)
11. Crumb tray
12. Cookie Sheet
13. Broil Tray

### Technical Specifications

Voltage: 120V., 60Hz.  
Power: 1500 Watts  
Capacity: 19 liter

Read all the sections of this booklet and follow all the instructions carefully.

## Before Using Your Toaster Oven

1. Read all of the instructions included in this manual.
2. Make sure that the oven is unplugged and the time control is in the “OFF” position.
3. Wash all the accessories in hot, soapy water or in the dishwasher.
4. Thoroughly dry all accessories and re-assemble in oven. Plug oven into outlet and you are ready to use your new **Toaster Oven**.
5. After re-assembling your oven, we recommend that you run it at the highest temperature (**450°F**) on the toast function for approximately **15 minutes** to eliminate any packing residue that may remain after shipping. This will also remove all traces of odor initially present.

**Please Note:** Initial start-up operation may result in minimal smell and smoke (about **15 minutes**). This is normal and harmless. It is due to burning of the protective substance applied to the heating elements in the factory.

## Keep Warm

Keep cooked food warm for up to **30 minutes**. Longer periods of time are not recommended as food will become dry or will spoil.

### Operation

- Set the temperature control to **150°F**.
- Turn the function control to “**Keep Warm**”.
- Turn the time control to the “**Stay On**” position.
- Turn the time control to the “**Off**” position when finished with keep warm.

**Caution:** When sliding trays out of oven, always support the rack. Do not let go until you are sure the rack is securely supported by the rack handle.

## Care & Cleaning

**Warning:** Be sure to unplug the oven and allow it to cool before cleaning.

To clean your oven, wipe the walls with a damp sponge, cloth or nylon scouring pad and mild detergent. **DO NOT USE STEEL WOOL SCOURING PADS, ABRASIVE CLEANERS OR SCRAPE THE WALLS WITH A METAL UTENSIL, AS THIS MAY DAMAGE THE UNIT.**

All accessories should be washed in hot soapy water or can be cleaned in a dishwasher. The door can be wiped with a damp sponge and wiped dry with a paper or cloth towel. Clean the outside with a damp sponge. **DO NOT USE AN ABRASIVE CLEANER AS IT MAY DAMAGE THE EXTERIOR FINISH.**

**DO NOT USE AN ABRASIVE CLEANER OR STEEL WOOL SCOURING PAD ON THE DRIP PAN AS IT MAY DAMAGE THE PORCELAIN ENAMEL FINISH.**

**LET ALL PARTS AND SURFACES DRY THOROUGHLY PRIOR TO PLUGGING OVEN IN AND USING.**

## Toasting

Large capacity oven allows for toasting 4 to 6 slices of bread, 6 muffins, frozen waffles or frozen pancakes. When toasting only 1 or 2 items, place food on the wire rack in the center of the oven.

### Operation

- Set the temperature control to **450°F**.
- Turn the function control to “**TOAST**”.
- Place food to be toasted on the wire rack.
- Ensure crumb tray is in place.
- Turn the time control to desired darkness (light to dark).
- Bell will ring to signal the end of the toast cycle.

**Note:** Wire rack should be positioned in the middle of the oven with the indentations pointing down.

## Grill

For best results, it is recommended that you preheat the oven for **15 minutes** on **450°F**.

### Operation

- Set temperature control to **450°F**.
- Turn function control to “**GRILL**”.
- Preheat the oven.
- Place the food on the broiler tray and slide into the top rack support guide or middle rack support guide depending on the thickness of the food that you are cooking.
- Food should be placed as close as possible to the top heating element without touching it.
- Set temperature control to the appropriate temperature.
- Brush food with sauces or oil, as desired.
- Turn time control to position “**STAY ON**”.
- It is advisable to leave the door slightly ajar.
- Turn food over midway through the prescribed cooking time.
- When grilling is complete, turn the time control to position “**OFF**”.

## Using Your Toaster Oven

Please familiarize yourself with the following oven functions and accessories prior to first use:

### **Temperature Control**

Choose the desired temperature from **150°F (Keep Warm)** to **450°F** for baking, broiling, toasting or grilling.

### **Function Control**

This oven is equipped with five positions for a variety of cooking needs:

- **Bake:** Cakes, pies, cookies, poultry, beef, pork, etc.
- **Toast:** Bread, muffins, frozen waffles, etc.
- **Grill:** For grilling fish, steak, sandwiches, bacon & eggs, etc.
- **Broil:** For broiling fish, steak, poultry, pork chops, etc.
- **Keep Warm:** To keep cooked food warm for up to **30 minutes**.

### **Time Control**

When you turn the control to the left, (counter-clockwise), the oven will stay on until it is manually shut off. To activate the timer segment of the control, turn to the right (clockwise) to toast or use as a timer. This function also has a bell that rings at the end of the programmed time.

### **Power “On” Light**

It is illuminated whenever the oven is turned on.

### **Broiler Tray**

For use in broiling and roasting meat, poultry, fish and various other foods.

**Warning:** TO AVOID RISK OF INJURY OR BURNS, DO NOT TOUCH HOT SURFACES WHEN OVEN IS IN USE. ALWAYS USE OVEN MITTS.

**Caution:** Always use extreme care when removing broiler tray, cookie sheet or any hot container from a hot oven. Always use an oven mitt when removing hot items from the oven.

## Broiling

The top heating elements cycle on and off to maintain maximum temperature in the oven. For best results, the oven should be preheated for **20 minutes** at **450°F** before adding the food to be broiled.

### Operation

- Set the temperature control to **450°F**.
- Turn the function control to “**BROIL**”.
- Preheat the oven.
- Place the food on the broiler tray and slide into the top rack support guide or middle rack support guide depending on the thickness of the food that you are cooking.
- Food should be placed as close as possible to the top heating element without touching it.
- Set temperature control to the appropriate temperature.
- Brush food with sauces or oil, as desired.
- Turn time control to position “**STAY ON**”.
- It is advisable to leave the door **slightly ajar**.
- When broiling is complete, turn the time control to “**OFF**”.

### Broiling Guide

Cooking results may vary, adjust these times to your individual requirements. Also, check often during broiling to avoid overcooking.

MEAT	OVEN TEMP	COOKING TIME
RIB STEAK	400	25-30 min.
T-BONE STEAK	400	25-30 min.
HAMBURGER	400	25-28 min.
PORK CHOPS	400	40-45 min.
LAMB CHOPS	400	30-40 min.
CHICKEN LEGS	400	30-35 min.
FISH FILETS	350	20-25 min.
SALMON STEAKS	350	20-25 min.

**Note:** All broiling times are based on meats at refrigerator temperature. Frozen meats may take considerably longer. Therefore, use of a meat thermometer is highly recommended.

## Baking

Bake your favorite cookies, cakes, pies, brownies, etc. The bakeware that will fit in your oven are up to **9 inches in length**. We **do not** recommend the use of oven roasting bags or glass containers in the oven. **Never use plastic, cardboard, paper or anything similar in the oven.**

**Note:** Position the wire rack in the lowest support guide.

### Operation

- Place the wire rack in the **lowest or middle** rack support guide depending on the height of the pan or according to the recipe.
- Place pan with item(s) to be baked on the wire rack.
- Turn the function control to “**BAKE**”.
- Set the temperature control to the desired temperature.
- Turn the time control to position “**STAY ON**”.
- When baking is complete, turn the time control to “**OFF**”.

### Baking On Two Racks

- Two racks of cookies can be baked at the same time, however it is necessary to rotate them (i.e. move the top to the bottom and the bottom to the top) halfway through the cooking time.

### Positioning of the Wire Racks

**Cookies:** Use bottom and middle support guides.

**Layer Cakes:** Use bottom support guide only (bake one at a time).

**Pies:** Use bottom support guide.

### Baking Cookies

For baking cookies, we suggest adjusting baking temperature and using the cookie sheets placed on the baking racks. Also, using parchment paper on the cookie sheets might prove helpful when baking certain types of cookies.

1. Use parchment paper on cookie sheets so cookies will not stick.
2. Cookie sheets, baking times and temperatures may differ from those necessary when using other baking materials.

### Baking Guide

Follow the package or recipe instructions for baking times and temperature.