

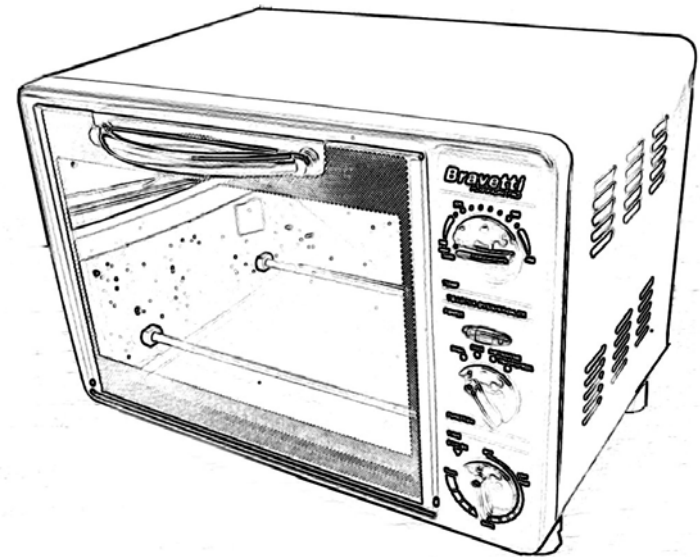

**Toaster Oven / Rotisserie
With Pizza Stone
Use and Care Instructions
Model EP277**



For information or assistance
call 514-842-8691

EURO-PRO Corporation
178 West Service Rd.
Champlain, NY 12919

IMPORTANT SAFEGUARDS

When using an electrical appliance, basic safety precautions should always be observed, including the following:

Read all instructions before using your ROTISSERIE OVEN/TOASTER.

WARNING: To reduce the risk of fire, electrical shock, or injury:

1. Read all instructions.
2. Do not touch hot surfaces. Always use handles or knobs.
3. Close supervision is necessary when any appliance is used by or near children.
4. To protect against electric shock, do not immerse cord, plug or any parts of the oven in water or any other liquids.
5. Do not let cord hang over edge of table or counter, or touch hot surfaces.
6. Do not operate appliance with damaged cord or plug or after the appliance malfunctions or has been damaged in any manner. Return appliance to EURO-PRO Corporation for examination, repair or adjustment.
7. The use of accessory attachments not recommended by the appliance manufacturer may cause hazard or injury.
8. Do not place on or near a hot gas or electric burner.
9. When operating the oven, keep at least four inches of free space on all sides of the oven to allow for adequate air circulation.
10. Unplug from outlet when not in use and before cleaning. Allow to cool before putting on or taking off parts, and before cleaning.
11. To disconnect, turn the time control to OFF, then remove the plug. Always hold the plug, and never pull the cord.
12. Extreme caution must be used when moving an appliance containing hot oil or other hot liquids.
13. Do not cover crumb tray or any part of the oven with metal foil. This may cause overheating of the oven.
14. Use extreme caution when removing the tray, racks or disposing of hot grease or other hot liquids.
15. Do not clean the inside of the oven with metal scouring pads. Pieces can break off the pad and touch electrical parts, creating a risk of electric shock.
16. Oversized foods or metal utensils must not be inserted in a toaster oven as they may create a fire or risk of electric shock.
17. A fire may occur if the oven is covered or touching flammable material, including curtains, draperies, walls and the like when in operation. Do not place any items on the oven during operation.
18. Extreme caution should be exercised when using cooking or baking containers constructed of anything other than metal or ovenproof glass.
19. Be sure that nothing touches the top or bottom elements of the oven.
20. Do not place any of the following materials in the oven: cardboard, plastic, paper, or anything similar.
21. Do not store any materials other than manufacturer's recommended accessories in this oven when not in use.
22. This appliance is OFF when the Timer Control button is in the "OFF" position.
23. Always wear protective, insulated oven gloves when inserting or removing items from the hot oven.
24. This appliance has a tempered, safety glass door. The glass is stronger than ordinary glass and more resistant to breakage. Tempered glass can still break edges. Avoid scratching door surface or nicking edges. If the door has a scratch or nick, contact EURO-PRO Corporation at (514) 842-8691 before using the oven.
25. Do not use outdoors.
26. Do not use appliance for other than for intended use.
27. This appliance is for HOUSEHOLD USE ONLY.

**SAVE THESE INSTRUCTIONS
FOR HOUSEHOLD USE ONLY
IMPORTANT SAFEGUARDS CONTINUED...**

Main Components

Rotisserie Oven/Toaster With Pizza Stone

Model EP277
120 Volt, 60 Hz
1500 watts
Dimensions: 16.5" x 14" x 12"

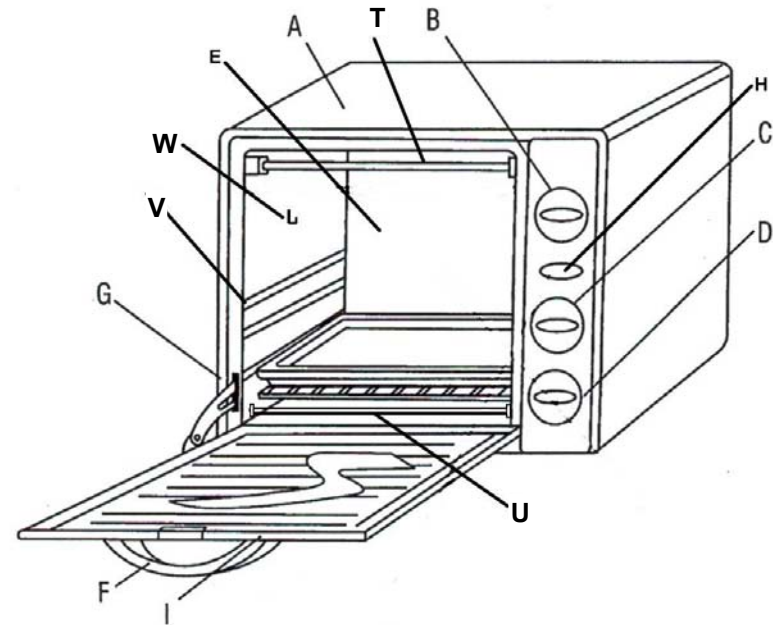

- | | |
|-------------------------------|------------------------------|
| A. HOUSING | M. PIZZA STONE |
| B. TEMPERATURE CONTROL | N. BAKE RACKS (2) |
| C. FUNCTION CONTROL | O. DRIP PAN |
| D. TIME CONTROL/ON/OFF SWITCH | P. BROILER RACK |
| E. INNER ENCLOSURE | Q. ROTISSERIE SKEWER |
| F. DOOR HANDLE | R. SKEWER CLAMP (2) |
| G. DOOR FRAME | S. THUMBSCREW (2) |
| H. ON-LIGHT INDICATOR | T. UPPER HEATING ELEMENT |
| I. GLASS DOOR | U. LOWER HEATING ELEMENT |
| J. TRAY/RACK HANDLE | V. RACK SUPPORT GUIDES |
| K. ROTISSERIE HANDLE | W. ROTISSERIE SKEWER SUPPORT |
| L. CRUMB TRAY | X. COOKIE SHEETS (2) |



Temperature Control



Function Control



Time Control ON/OFF SWITCH

3

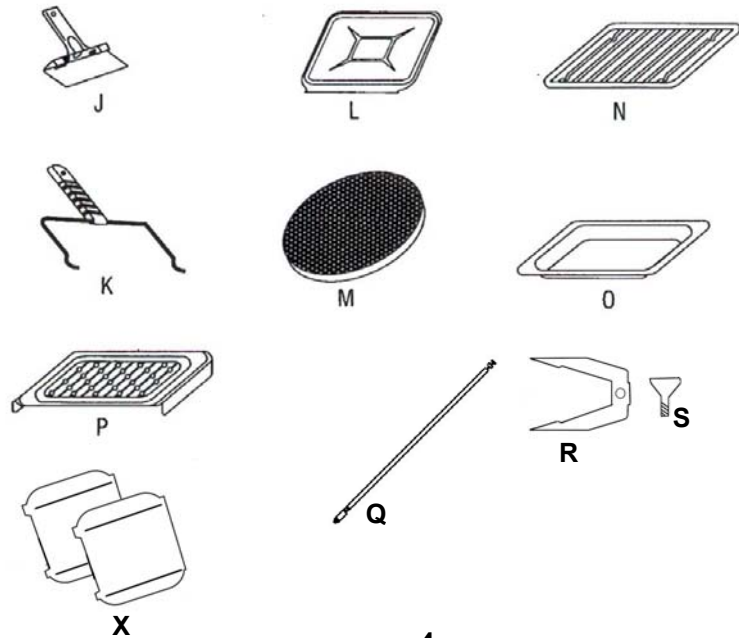

4

Read all the sections of this booklet and follow all the instructions carefully.

Before Using Your Rotisserie Oven / Toaster

Before using your Rotisserie Oven / Toaster for the first time, be sure to:

1. Read all of the instructions included in this manual.
2. Make sure that the oven is unplugged and the Time Control (D) is in the "OFF" position.
3. Wash the racks (N), drip pan (O), broiler rack (P) and crumb tray (L) in hot, soapy water or in the dishwasher. Also remove the rotisserie skewer (Q), skewer clamps (S) and pizza stone (M) from the packaging and wash these in hot, soapy water.
4. Thoroughly dry all accessories and re-assemble in oven. Plug oven into outlet and you are ready to use your new Rotisserie Oven/ Toaster.
5. After re-assembling your oven, we recommend that you run it at the highest temperature (450° F.) on the Toast & Pizza Function for approximately 15 minutes to eliminate any packing oil that may remain after shipping. This will also remove all traces of odor initially present.

Please Note: Initial start-up operation may result in minimal smell and smoke (about 15 minutes). This is normal and harmless. It is due to burning of the protective substance applied to the heating elements in the factory.

Using Your Rotisserie Oven / Toaster

Please familiarize yourself with the following oven functions and accessories prior to the first use:

- Temperature Control (B) - Choose the desired temperature from Keep Warm to 450° F for baking or rotisserie.
- Function Control (C) - This oven is equipped with four positions for a variety of cooking needs:
 - Bake/Roast - Cakes, pies, cookies, poultry, beef, pork, etc.
 - Toast/Pizza - Bread, muffins, frozen waffles, pizza, etc.
 - Rotisserie - Can cook up to a 5-lb roast or chicken
 - Broil - For broiling fish, steak, poultry, pork chops, etc.
- Time Control (D) - When you turn the control to the left, (counter-clockwise), the oven will stay "ON" until it is manually shut "OFF". To activate the timer segment of the control, turn to the right (clockwise) to toast or use as a timer. This function also has a bell that rings at the end of the programmed time.

Before Using Your Rotisserie Oven / Toaster cont.

- On-Light Indicator (H) - It is illuminated whenever the oven is turned on.
- 2 Bake Racks (N)- For toasting, baking and general cooking for casserole dishes and standard pans.
- Drip Pan and Broiler Rack (O & P) - For use in broiling and roasting meat, poultry, fish and various other foods. The broiler rack (P) allows the fat drippings to drip into the drip pan (O) and away from the food. This will help prevent spattering that could result in smoke and flare ups.
- **NOTE:** Always use the drip pan (O) with the bake rack (N) when roasting and broiling meats, fish and poultry.
- Tray/Rack Handle (J) - Allows you to pick up the bake rack (N), drip pan (O) and broiler rack (P) when they are hot.
- Rotisserie Skewer (Q) - Roasts a variety of meats and poultry that are very tender and juicy inside, and browned to perfection outside.
- Rotisserie Handle (K) - Used for removing the rotisserie skewer from the oven after your roast is done.
- Pizza Stone (M) - Used for cooking pizza or baking cookies.

WARNING: TO AVOID RISK OF INJURY OR BURNS, DO NOT TOUCH HOT SURFACES WHEN OVEN IS IN USE. ALWAYS USE OVEN MITTS.

Caution: Always use extreme care when removing rotisserie, broiler rack, drip pan, bake racks, crumb tray, pizza stone or any hot container from a hot oven. Always use the tray/rack handle, rotisserie handle or an oven mitt when removing these items.

Rotisserie Cooking

We recommend that you do not cook a roast larger than 4-5 lbs. on the skewer (Q). Chicken should be bound in string to prevent the chicken legs or wings from unraveling during roasting and so that rotisserie assembly will rotate smoothly. For best results we recommend that you preheat the oven for 15 minutes on 450°.

Operation

- Set temperature control (B) to 450°F.
- Turn function control (C) to rotisserie. Insert pointed end of skewer clamp (R) through rotisserie skewer (Q), making sure the points of the skewer clamp (R) face in the same direction as pointed end of rotisserie skewer (Q). Slide skewer clamp (R) towards square of the rotisserie skewer (Q) and secure with thumbscrew (S).
- Place food to be cooked on the rotisserie skewer (Q) by inserting the rotisserie skewer (Q) directly through the center of the food.
- Place the second skewer clamp (R) into the other end of the roast or poultry and secure skewer clamp (R) with thumbscrew (S).
- Check that the food is centered on the rotisserie skewer.
- Insert the pointed end of the rotisserie skewer (Q) into the drive socket located on the right hand side of the oven wall. Make sure the square end of the rotisserie skewer (Q) rests on the rotisserie skewer support (W) located on the left hand side of the oven wall.
- Slide the drip pan (O) into the lowest position to catch the food drippings.
- Turn the time control (D) to the "ON" position
- Use the rotisserie guide for suggested roasting times. Check the doneness with a reliable meat thermometer. Use an independent timer to remind you to check the meat temperature.
- When complete, turn the time control (D) to the "OFF" position.
- Remove the spit by placing the hooks of the rotisserie handle (K) under the grooves on either side of the rotisserie skewer (Q). Lift the left side of the rotisserie skewer (Q) first by lifting it up and out. Then pull the rotisserie skewer (Q) out of the drive socket and carefully remove the roast from the oven. Take the meat off of the rotisserie skewer (Q) and place on cutting board or platter.

Rotisserie Guide

Cooking results may vary, adjust these times to your individual requirements.

MEAT	OVEN TEMP	TIME PER LB.
BEEF ROAST	325	30-35 min.
PORK ROAST	325	45-50 min.
HAM	325	45-50 min.
CHICKEN	350	25-30 min.
TURKEY	350	25-30 min.

Note: All roasting times are based on meats at refrigerator temperature. Frozen meats may take considerably longer. Therefore, use of a meat thermometer is highly recommended.

Roasting In Your Oven

Roast your favorite cut of meat to perfection. The oven can cook up to an 8-lb. chicken or turkey and up to a 6-lb. roast. A guide has been provided to assist you with roasting times. However, we suggest that you periodically check the cooking progress with a meat thermometer. For best results we recommend that you preheat the oven for 15 minutes on 450°. We do not recommend the use of oven roasting bags or glass containers in the oven. **Never** use plastic cardboard, paper or anything similar in the oven.

Operation

- Place the baking rack (N) in the oven at the lowest position.
- Place food to be cooked in the drip pan (O).
- Place the drip pan (O) on the baking rack (N).
- Set the temperature control (B) to the desired temperature.
- Turn the function control (C) to bake.
- Turn the time control (D) to the "STAY ON" position.
- To check or remove roast, use the tray/rack handle (J) provided to help you slide the roast in and out.
- When cooking is complete, turn the time control (D) to "OFF" position.

Roasting Guide

Cooking results may vary, adjust these times to your individual requirements.

MEAT	OVEN TEMP	TIME PER LB.
BEEF ROAST	325	25-30 min.
PORK ROAST	325	40-45 min.
HAM	325	35-40 min.
CHICKEN	350	20-25 min.
TURKEY	350	20-25 min.

Note: All roasting times are based on meats at refrigerator temperature. Frozen meats may take considerably longer. Therefore, use of a meat thermometer is highly recommended.

Broiling

For best results, it is recommended that you preheat the oven for 15 minutes on 450°.

Operation

- Set Temperature Control (B) to 450°.
- Turn Function Control (C) to Broil.
- Preheat the oven.
- Place the Broiler Rack (P) on the Drip Pan (O).
- Place the food on the Broiler Rack (P) and slide into the Top Rack Support Guide (V) or Middle Rack Support Guide (V) depending on the thickness of the food that you are cooking.
- Food should be placed as close as possible to the Top Heating Element (T) without touching it.
- Set temperature control (B) to the appropriate temperature.
- Brush food with sauces or oil, as desired.
- Turn Time Control (D) to "ON".
- It is advisable to leave the door slightly ajar.
- Turn food over midway through the prescribed cooking time.
- When broiling is complete, turn the Time Control (D) to "OFF".

Broiling Guide

Cooking results may vary, adjust these times to your individual requirements. Also, check often during broiling to avoid over cooking.

MEAT	OVEN TEMP	COOKING TIME
RIB STEAK	400	25-30 min.
T-BONE STEAK	400	25-30 min.
HAMBURGER	400	25-28 min.
PORK CHOPS	400	40-45 min.
LAMB CHOPS	400	30-40 min.
CHICKEN LEGS	400	30-35 min.
FISH FILETS	350	20-25 min.
SALMON STEAKS	350	20-25 min.

Note: All broiling times are based on meats at refrigerator temperature. Frozen meats may take considerably longer. Therefore, use of a meat thermometer is highly recommended.

Baking

Bake your favorite cookies, cakes, pies, brownies, etc. The bakeware that will fit in your oven are up to 9 inches in length. We do not recommend the use of oven roasting bags or glass containers in the oven. **Never** use plastic cardboard, paper or anything similar in the oven.

Note: When using a single bake rack (N), position the Bake Rack (N) in the lowest Support Guide (T).

Operation

- Place the Bake Rack (N) in the lowest or middle Rack Support Guide (V) depending on the height of the pan or according to the recipe.
- Preheat the oven as directed in the recipe, approximately 15 minutes.
- Place pan with item(s) to be baked on the Bake Rack (N).
- Turn the Function Control (C) to BAKE.
- Turn the Time Control (D) to "ON".
- When baking is complete, turn the Time Control (D) to "OFF".

Baking On 2 Racks

- Two racks of cookies or pies can be baked at the same time, however it is necessary to rotate them (i.e. move the top to the bottom and the bottom to the top) halfway through the cooking time.

Positioning of the Bake Racks

Cookies - Use bottom and middle Support Guides (V).

Layer Cakes - Use bottom Support Guide (V) only (bake one at a time).

Pies - Use bottom and middle Support Guides (V).

Baking Cookies

For baking cookies, we suggest adjusting baking temperature and using the cookie sheets (X) placed on the baking racks. Also, using parchment paper on the cookie sheets (X) might prove helpful when baking certain types of cookies.

1. Place cookie sheets (X) on the bake racks, switch on the oven and begin baking only after the oven has been preheated for 15 minutes.
2. Use parchment paper on cookie sheets (X) so cookies will stick.
3. Cookie sheets (X) baking times and temperatures may differ from those necessary when using other materials.

Baking Guide

Follow the package or recipe instructions for baking times and temperature.

Toasting

Large capacity oven allows for toasting 4 to 6 slices of bread, 6 muffins, frozen waffles or frozen pancakes. When toasting only 1 or 2 items, place food on the bake rack (N) in the center of the oven.

Operation

- Set the Temperature Control (B) to 450°.
- Turn the Function Control (C) to Toast and Pizza.
- Place food to be toasted on the Bake Rack (N).
- Ensure Crumb Tray (L) is in place.
- Turn the Time Control (D) to desired darkness. (Light to Dark).
- Bell will signal the end of the Toast cycle.

Note: Bake Rack (N) should be positioned in the middle of the oven with the indentations pointing down.

Using the Pizza Stone

Your Pizza Stone (M) heats evenly, absorbs moisture and cooks without fats, making each dish a success.

Operation

- Preheat oven for 15 minutes on 450°.
- Turn the Function Control (C) to Toast and Pizza.
- Set Timer Control (D) to "ON" position.
- Then lower temperature according to baking instructions.
- Place pizza stone (M) on the bake rack (N) and begin baking.
- Do not use oil or other fats on the pizza stone (M). You can add a light dusting of flour so that dough will not stick to pizza stone (M).
- Pizza stone (M) baking times and temperature may differ from those necessary when using other baking pans.
- When pizza is ready, turn the Time Control (D) to "OFF" position.
- For cleaning, residues can be eliminated from pizza stone (M) using a spatula or a knife. For deeper cleaning, heat pizza stone (M) in the oven, brush it with a scouring pad (do not use detergents) and rinse well with hot water.
- With use, the pizza stone (M) will darken but its characteristics will remain unchanged.

Preparation & Cooking Time

- Frozen Pizzas - Cook for 5-8 minutes or as indicated on the package. It is advisable to remove the pizza from the freezer 10 minutes before placing in the oven. Place pizza on pizza stone to bake.
- Pizza Mix - Follow the instructions on the box. Place pizza on pizza stone to bake. Cook for 18-25 minutes.
- Pizza From Scratch - Follow the recipe instructions. Place pizza on pizza stone to bake.

Keep Warm

Keep cooked food warm for up to 30 minutes. Longer periods of time are not recommended as food will become dry or will spoil.

Operation

- Set the Temperature Control (B) to Keep Warm.
- Turn the Function Control (C) to Bake.
- Turn the Time Control (D) to ON.
- Turn the Time Control (D) to OFF when finished with Keep Warm.

CAUTION: When sliding rack out of oven, always support the rack. Do not let go until you are sure the rack is securely supported by the rack guides.

Care & Cleaning

Warning: Be sure to unplug the oven and allow it to cool before cleaning.

Your oven features a continuous clean coating that automatically cleans itself during normal operation. Any spattering that occurs while cooking and comes into contact with the continuous coating is oxidized while the oven is in operation. If desired, wipe the walls with a damp sponge, cloth or nylon scouring pad and mild detergent. **DO NOT USE STEEL WOOL SCOURING PADS, ABRASIVE CLEANERS OR SCRAPE THE WALLS WITH A METAL UTENSIL, AS ALL OF THESE METHODS MAY DAMAGE THE CONTINUOUS CLEAN COATING.**

All accessories should be washed in hot soapy water or can be cleaned in a dishwasher. The door can be wiped with a damp sponge and wiped dry with a paper or cloth towel. Clean the outside with a damp sponge. **DO NOT USE AN ABRASIVE CLEANER AS IT MAY DAMAGE THE EXTERIOR FINISH.**

DO NOT USE AN ABRASIVE CLEANER OR STEEL WOOL SCOURING PAD ON THE DRIP PAN AS IT MAY DAMAGE THE PORCELAIN ENAMEL FINISH.

LET ALL PARTS AND SURFACES DRY THOROUGHLY PRIOR TO PLUGGING OVEN IN AND USING.