

KC275



## ONE (1) YEAR LIMITED WARRANTY

**EURO-PRO OPERATING LLC** warrants this product to be free from defects in material and workmanship for a period of one (1) year from the date of purchase when utilized for normal household use.

If your appliance fails to operate properly while in use under normal household conditions within the warranty period, return the complete appliance and accessories, freight prepaid to:

US.: **EURO-PRO Operating LLC**, 94 Main Mill Street, Door 16, Plattsburgh, NY 12901

CANADA: **EURO-PRO Operating LLC**, 4400 Bois Franc, St. Laurent, QC, H4S 1A7

If the appliance is found to be defective in material or workmanship, **EURO-PRO Operating LLC** will repair or replace it free of charge. Proof of purchase date and \$12.95 to cover the cost of return shipping and handling must be included.\*

The liability of **EURO-PRO Operating LLC** is limited solely to the cost of the repair or replacement of the unit at our option. This warranty does not cover normal wear of parts and does not apply to any unit that has been tampered with or used for commercial purposes. This limited warranty does not cover damage caused by misuse, abuse, negligent handling or damage due to faulty packaging or mishandling in transit.

This warranty is extended to the original purchaser of the unit and excludes all other legal and/or conventional warranties. The responsibility of **EURO-PRO Operating LLC** if any, is limited to the specific obligations expressly assumed by it under the terms of the limited warranty. **In no event is EURO-PRO Operating LLC** liable for incidental or consequential damages of any nature whatsoever. Some states/provinces do not permit the exclusion or limitation of incidental or consequential damages, so the above may not apply to you.

This warranty gives you specific legal rights, and you may also have other rights which vary from state to state, or province to province.

**\*Important: Carefully pack item to avoid damage in shipping. Be sure to include proof of purchase date and to attach tag to item before packing with your name, complete address and phone number with a note giving purchase information, model number and what you believe is the problem with item. We recommend you insure the package (as damage in shipping is not covered by your warranty). Mark the outside of your package "ATTENTION CUSTOMER SERVICE". We are constantly striving to improve our products, therefore the specifications contained herein are subject to change without notice.**



### OWNERSHIP REGISTRATION CARD FOR CANADIAN CONSUMERS ONLY

Please fill out and mail the product registration card within ten (10) days of purchase. The registration will enable us to contact you in the unlikely event of a product safety notification. By returning this card you acknowledge to have read and understood the instructions for use, and warnings set forth in the accompanying instructions.

RETURN TO **EURO-PRO OPERATING LLC**, 4400 Bois Franc, St. Laurent, QC, H4S 1A7

**KC275**

Appliance model

Date purchased Name of store

Owner's name

Address City Province Postal Code

Printed in China



## 7-Quart Programmable Slow Cooker With Bonus Little Cooker

### OWNER'S MANUAL

Model **KC275**

120V., 60Hz., 340 Watts

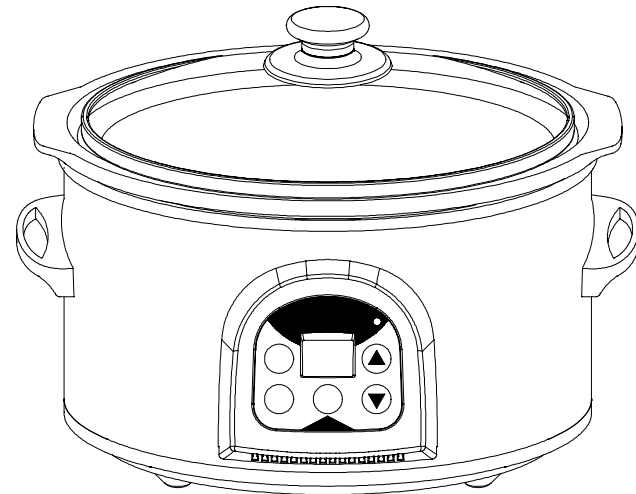

**USA:** **EURO-PRO Operating LLC**  
94 Main Mill Street, Door 16  
Plattsburgh, NY 12901

**Canada:** **EURO-PRO Operating LLC**  
4400 Bois Franc  
St. Laurent, QC H4S 1A7

Tel.: 1 (800) 798-7398  
www.euro-pro.com

# IMPORTANT SAFETY INSTRUCTIONS

When using your Programmable Slow Cooker, basic safety precautions should always be followed, including the following:

1. Read all instructions carefully.
2. Use Programmable Slow Cooker only for its intended use.
3. To protect against risk of electrical shock, **do not** immerse the power cord, plug or main unit in water or other liquids.
4. **Do not** touch hot surfaces. Always use handles or knobs.
5. Close supervision is necessary for any appliance being used by or near children.
6. Always disconnect appliance from electrical outlet when not in use and before cleaning. Allow unit to cool before putting on or taking off parts and before cleaning the appliance.
7. **Do not** operate appliance with a damaged cord or plug or after the appliance malfunctions or has been dropped or damaged in any manner. Return the appliance to **EURO-PRO Operating LLC** for examination and repair.
8. **Do not** let cord hang over edge of table or counter, or touch hot surfaces.
9. **Do not** place on or near a hot gas or electric burner.
10. **This appliance is for household use only.**
11. The use of accessory attachments not recommended by the appliance manufacturer may cause hazard or injury.
12. **Do not** use outdoors.
13. **Never** place the removable ceramic pot directly on a heated surface as this may cause the ceramic pot to crack.
14. To disconnect the appliance, turn appliance "Off" first and then remove the plug from the electrical outlet. Always hold the plug and never pull the power cord.
15. **CAUTION: Extreme caution must be used when moving an appliance containing hot oil or other hot liquids. Always use pot holders when moving your heated Programmable Slow Cooker.**
16. The glass lid and removable ceramic pot are fragile. Handle them with care.

17. **WARNING! TO PREVENT ELECTRIC SHOCK, never immerse the main unit in water or other liquids.**
18. Avoid sudden temperature changes, such as adding cold or frozen ingredients into a heated pot.
19. **Never** cook directly in metal housing. Use the removable ceramic pot.
20. **Never** turn the appliance "On" when the ceramic pot is empty as this could cause a malfunction.
21. **Do NOT** immerse. Only the removable ceramic insert and glass lid may be immersed for cleaning.
22. When using this appliance, provide adequate air space above and on all sides for air circulation. On surfaces where heat may cause a problem, an insulated heat pad is recommended.
23. **Do NOT** use slow cooker to boil water.
24. **CAUTION: When removing the glass lid, always lift and tilt the lid away from you carefully to avoid scalding and allow water to drip back into the unit.**

**WARNING:** To reduce the risk of electric shock, this appliance has a polarized plug (one blade is wider than the other). This plug will fit in a polarized outlet only one way. If the plug does not fit fully in the outlet, reverse the plug. If it still does not fit, contact a qualified electrician to install the proper outlet. Do not modify the plug in any way.

## SPECIAL INSTRUCTIONS

This appliance has a short power cord to reduce the risk resulting from becoming entangled in or tripping over a long cord. An extension cord may be used if you are careful in its use:

1. The electrical rating of the extension cord should be at least as great as the electrical rating of the appliance.
2. An extension cord with the power cord must be arranged so that it will not drape over the countertop or tabletop where they can be pulled on by children or tripped accidentally.

# SAVE THESE INSTRUCTIONS FOR HOUSEHOLD USE ONLY

**WARNING:** To reduce the risk of electric shock, this appliance has a polarized plug (one blade is wider than the other). This plug will fit in a polarized outlet only one way. If the plug does not fit fully in the outlet, reverse the plug. If it still does not fit, contact a qualified electrician to install the proper outlet. **Do not modify the plug in any way.**

## GETTING TO KNOW YOUR LITTLE COOKER

Before using your Little Cooker, remove any labels, stickers or tags that may be attached to the appliance.

When turned on for the first time, your new slow cooker may emit an odor for up to 10 minutes. This is due to the initial heating of the materials used in making the slow cooker. The odor is safe and should not reoccur after initial heating.



## Technical Specifications

Voltage: 120V., 60Hz.  
Power: 40 Watts  
Capacity: 13 U.S. Fl. Oz.

1. Metal Housing
2. Non-Removable Ceramic Pot
3. Lid

## OPERATING INSTRUCTIONS

This appliance is for HOUSEHOLD USE ONLY and may be plugged into any 120V AC polarized electrical outlet.

**Do not use any other type of outlet.**

### Using Your Little Cooker for the First Time

Prior to first use, clean the appliance thoroughly.

1. Wash the lid in hot, soapy water and wipe with a damp cloth the inside of the ceramic container. **DO NOT IMMERSE** unit in water or any other liquid. **DO NOT** place little cooker in dishwasher.
2. Plug the power cord into a 120 volt AC outlet.
3. Always cook with the lid in place. Remember that frequent lifting of the lid will delay the cooking time.
4. Unplug the slow cooker when the cooking process is complete. Allow to cool completely before cleaning. **The ceramic pot cannot withstand the shock of sudden temperature changes.**
5. **Do not** use slow cooker to boil water.

**CAUTION:** Be careful when adding additional liquids to ceramic pot - **Never** add cold liquids as this might cause the ceramic pot to crack. Always warm the liquids before adding.

### Care & Maintenance

**CAUTION:** Make sure that the unit is unplugged from the power source before cleaning.

- Always allow unit to cool before cleaning.
- Wash lid with hot, soapy water. You could also place it in the top rack of the dishwasher.
- Wash ceramic pot with a damp cloth. **DO NOT IMMERSE** unit in water or any other liquid.
- **Never** use abrasive cleansers or metal scouring pads to clean the ceramic pot or lid.
- To soften stubborn, cooked on foods, fill the ceramic pot with warm, soapy water and allow to soak. Remove by lightly scrubbing with a nylon kitchen brush.
- Clean the metal housing only with a damp cloth. When storing your little cooker, loosely coil the power cord, do not wrap the cord around the unit.

## COOKING RECIPES

### French Onion Beef

#### Ingredients:

- 1 1/4 lb. boneless beef round steak (1/2 to 3/4-inch thick)
- 8 oz. sliced fresh mushrooms
- 1 large white onion, sliced into rings
- 1 10 3/4-oz can condensed French onion soup
- 1 6-oz pkg. instant herb stuffing mix
- 1/4 cup melted butter or margarine
- 4-oz shredded mozzarella cheese

#### Directions:

Cut the beef into 6 serving size pieces. Layer half of the beef, mushrooms and onion rings in the slow cooker; repeat layers. Pour soup over ingredients in slow cooker. Cover and cook on Low setting for 8 to 10 hours or until beef is tender and no longer pink.

Before serving, in medium bowl, combine stuffing mix, contents of seasoning packet, melted butter or margarine and 1/2 cup of the liquid from the slow cooker; toss to mix. Place stuffing on top of contents in slow cooker. Increase heat setting to High. Cover and cook an additional 20 minutes or until stuffing is fluffy. Sprinkle with cheese. Cover and cook until cheese is melted.

### Warm Apple Crisp

#### Ingredients:

- 6-8 cups apples, peeled, cored and cut into slices
- 2 cups bread crumbs
- 1 cup brown sugar
- 1 tsp cinnamon
- 1 tsp nutmeg
- 1/8 tsp salt
- 1/2 cup butter or margarine melted
- 1/4 cup walnuts, finely chopped (optional)

#### Directions:

Place the apples in the bottom of the ceramic pot. In a mixing bowl, combine the bread crumbs, brown sugar, cinnamon, nutmeg, salt, melted butter or margarine and walnuts. Spread mixture over apples in the ceramic pot. Cover and cook on Low setting for 3 hours 30 minutes or on High for 2 hours 45 minutes.

## GETTING TO KNOW YOUR PROGRAMMABLE SLOW COOKER

Before using your 7-Quart Programmable Slow Cooker, remove any labels, stickers or tags that may be attached to the appliance.

When turned on for the first time, your new slow cooker may emit an odor for up to 10 minutes. This is due to the initial heating of the materials used in making the slow cooker. The odor is safe and should not reoccur after initial heating.

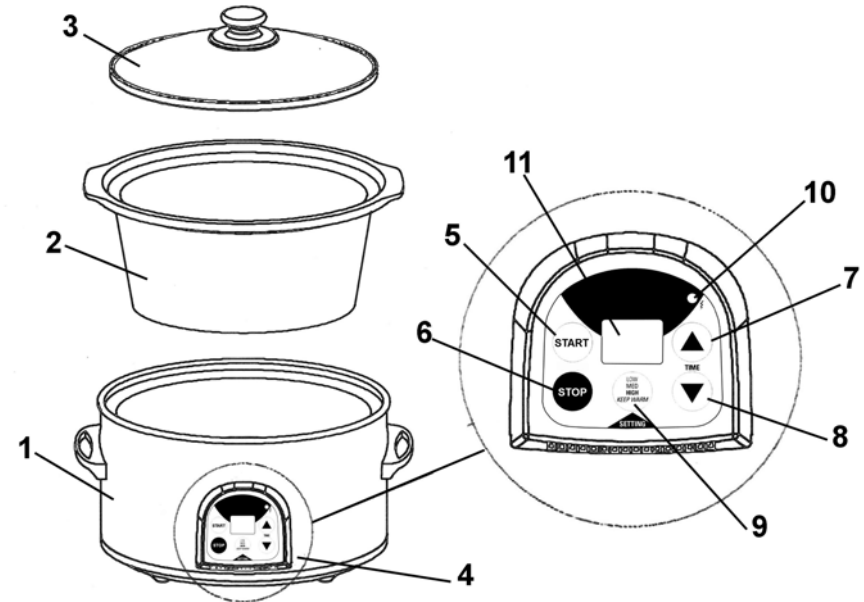

- |                   |                             |
|-------------------|-----------------------------|
| 1. Metal Housing  | 7. Time Increase            |
| 2. Ceramic Pot    | 8. Time Decrease            |
| 3. Glass Lid      | 9. Settings Selector Button |
| 4. Control Panel  | 10. Power "On" Light        |
| 5. "Start" Button | 11. LCD Screen              |
| 6. "Stop" Button  |                             |

### Technical Specifications

Voltage: 120V., 60Hz.  
Power: 340 Watts

\* Illustrations may differ from actual product.

## FEATURES OF 7-QUART PROGRAMMABLE SLOW COOKER

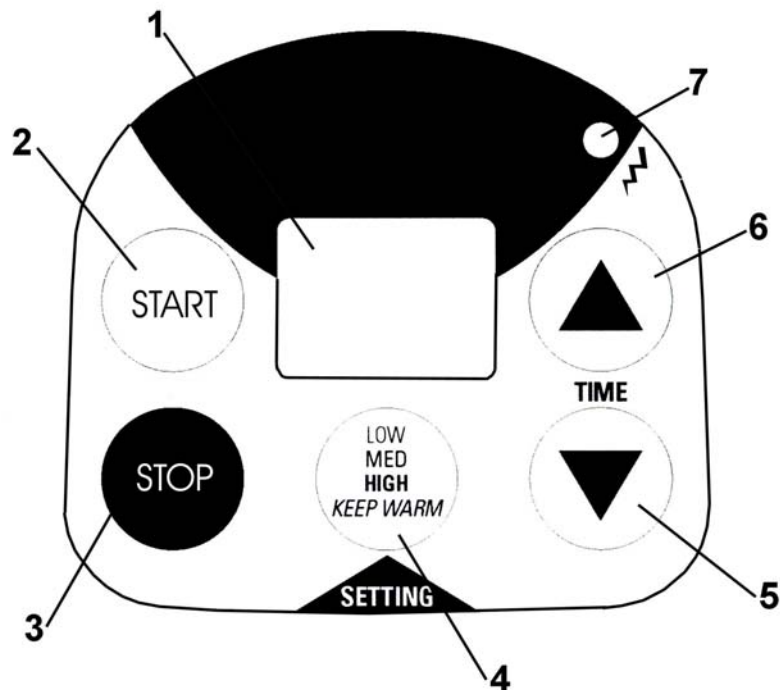

1. **LCD DISPLAY SCREEN**  
The LCD screen will display the time, heat setting and cooking or stand by modes.
2. **START BUTTON**  
The unit will start cooking when this button is pressed. It will begin cooking and counting down if a time was programmed, or it will begin cooking and counting up if a time was not programmed.
3. **STOP BUTTON**  
Pressing this button will stop the cooking process and put you in stand-by mode.
4. **SETTING BUTTON**  
Pressing this button will select the cooking temperature that you desire: High, Medium, Low or Keep Warm.
5. **TIME DECREASE**  
Pressing this button will decrease the cooking time in 30 minute increments.
6. **TIME INCREASE**  
Pressing this button will increase the cooking time in 30 minute increments.
7. **POWER ON LIGHT**  
This will turn on (red) when the unit is working.

## COOKING RECIPES

### Spicy Shrimp & Sausage Jambalaya

#### Ingredients:

2 cups	sausage, diced
1 lb	frozen, cooked shrimp, shelled and cleaned (thawed)
2	medium onions, coarsely chopped
2	stalks celery, sliced
1/2	green pepper, seeded and diced
1/2	red pepper, seeded and diced
1 28-oz	can whole tomatoes
1/4 cup	tomato paste
3	cloves garlic, minced
1 tsp	dried parsley
1/2 tsp	thyme
1 tsp	Tabasco® sauce
2	whole cloves
2 Tbsp	olive oil
1 cup	raw white rice

#### Directions:

Brown sausage in large skillet over medium heat, stirring until it has browned evenly. Add sausage to ceramic pot. Add the rest of the ingredients except the shrimp to the ceramic pot and mix thoroughly. Cover and cook on Low setting for 8 hours or on High for 4 hours. One hour before serving, turn to High setting and stir in the shrimp.

### Vegetable Minestrone

#### Ingredients:

2 cups	vegetable or chicken broth
2 cups	tomato juice
1/2 tbs.	dried basil leaves
1/2 tsp.	salt
1/4 tsp.	dried oregano leaves
1/4 tsp.	pepper
2	medium carrots, sliced (1 cup)
2	medium celery stalks, chopped (1 cup)
1	medium onion, chopped (1/2 cup)
1/2 cup	sliced fresh mushrooms (3 ounces)
2	garlic cloves, finely chopped
1	can (28 ounces) diced tomatoes, undrained
1 cup	uncooked rotini pasta
	Shredded Parmesan cheese, if desired

#### Directions:

Mix all ingredients except pasta and cheese in slow cooker. Cover and cook on low heat setting 7 to 8 hours or until vegetables are tender. Stir in pasta. Cover and cook on high heat setting 15 to 20 minutes or until pasta is tender. Sprinkle each serving with cheese.

### Teriyaki Chicken Wings

**Ingredients:**

- 3 lbs chicken wings
- 1 large onion, chopped
- 1/2 cup soy sauce
- 1/2 cup brown sugar
- 1 tsp. ground ginger
- 2 cloves garlic, minced
- 1/3 cup dry cooking sherry

**Directions:**

Rinse the chicken and pat dry. Cut off and discard wing tips. Cut each wing at the joint to make two sections. Place the wing parts on a broiler pan. Broil 4 to 5 inches from the heat for 20 minutes, 10 minutes on each side or until chicken is brown. Transfer to the slow cooker.

Mix together the onion, soy sauce, brown sugar, ginger, garlic, and cooking sherry in a bowl. Pour over the chicken wings. Cover; cook on Low for 5 to 6 hours or on High for 2 to 3 hours. Stir chicken wings. Be sure wings are evenly coated with sauce.

### Buffalo Wings with Blue Cheese Dip

**Ingredients:**

- 4 lbs. chicken wings
- 1 1/2 cups bottled chili sauce
- 3-4 Tbsp bottled hot pepper sauce
- blue cheese dip or bottled Ranch salad dressing

**Directions:**

Cut off and discard wing tips. Cut each wing into 2 sections. Rinse chicken; pat dry. Place chicken on the unheated rack of a broiler pan. Broil 4-5 inches from the heat for about 10 minutes or until the chicken is browned, turning over once. Transfer chicken wings to slow cooker.

Combine chili sauce and hot pepper sauce and pour over chicken wings. Cover; cook on Low setting for 5 to 6 hours or on High for 2 to 3 hours. Serve Buffalo wings with Ranch or Blue Cheese.

This appliance is for HOUSEHOLD USE ONLY and may be plugged into any 120V AC polarized electrical outlet.

**Do not use any other type of outlet.**

### Using Your Programmable Slow Cooker for the First Time

Prior to first use, clean the appliance thoroughly.

1. Wash the glass lid and the ceramic pot in hot, soapy water.
2. Rinse and dry thoroughly.
3. **Do not** immerse metal housing in water.
4. Plug the power cord into a 120 volt AC outlet.
5. Always cook with the glass lid in place and the ceramic pot in position. Remember that frequent lifting of the glass lid will delay the cooking time.
6. When cooking a meat and vegetable combination, place the meat in the bottom of the ceramic pot.
7. Unplug the slow cooker when the cooking process is complete. Allow to cool completely before cleaning.
8. **Do not** use frozen meat or poultry in a slow cooker. Thaw any meat or poultry before slow cooking.
9. Follow recommended cooking times.
10. **Do not** use the ceramic pot for storage of foods.
11. **Do not** reheat foods in the slow cooker. do not set heated unit with food on a finished wood table. Always use protective padding under ceramic pot before setting on table or countertop.
12. **Do not** use slow cooker to boil water.

**CAUTION: Be careful when adding additional liquids to ceramic pot - Never add cold liquids as this might cause the ceramic pot to crack. Always warm the liquids before adding.**

### Programming the Slow Cooker

1. Plug the unit in to a polarized electrical outlet. You will hear one (1) long beep and the LCD display screen will light up. It will display "P-On" for one (1) second and then change to show the initial status "STAND\_BY" and default heat setting "HIGH".
2. Press the "Setting" button and then press on the timer increase button to set the cooking time. The time will increase in thirty (30) minute increments.
3. Press the setting button once again to set the cooking temperature "HIGH, MEDIUM, LOW or KEEP WARM".
4. Once you have selected the desired cooking temperature, press on the "Start" button to begin cooking.
5. The timer will now start counting the time down to "0".
6. When set cooking time has expired, the unit will beep once and then go into Stand-By mode for five (5) minutes. After the five (5) minutes have passed it will go into "Keep Warm" mode for six (6) hours and then it will automatically turn "Off".
7. To stop the cooking process at any time during the operation, press on the "STOP" button and the unit will go back into "Stand-By" mode immediately and the "Power On" light will go off. The timer will be cleared and only the heat setting will remain. If you wish to restart the cooking process, you must reset the timer.
8. If you do not set any time, the unit will work in a "Count Up" mode to a maximum of twenty-four (24) hours. Once this time has passed, it will beep once and go into Stand-By mode for five (5) minutes. After the five (5) minutes have passed it will automatically go into "Keep Warm" mode for six (6) hours and then shut off.

## Using Your Programmable Slow Cooker

1. Prepare your recipe according to directions.
2. Place prepared food into the removable ceramic pot and cover with the glass lid.
3. Plug the unit into an electrical outlet and set the time and desired temperature setting. It is not necessary to stir the ingredients during the cooking process.
4. Cooking times may differ by the amount of ingredients, room temperature and many other factors. Adjust the cooking time in reference to the actual result.
5. Repeatedly removing the glass lid will decrease the temperature in the ceramic pot and lengthen the cooking times.
6. Certain dishes may not cook if the room temperature is below 41°F or 5°C.
7. When finished, press the "Stop" button and unplug the unit. You can serve the meal in the ceramic pot.
8. When removing the glass lid, tilt so that the opening faces away from you to avoid being burned by the steam. **Note: The glass lid and the ceramic pot are hot.** Use a cloth or pot holder to hold them. Exercise caution to avoid burns.
9. The sides of the metal housing of the slow cooker get very warm. Use oven mitts or pot holders to remove the ceramic pot.
10. Let ceramic pot and glass lid cool completely before washing.

## Guide To Slow Cooking

Always allow sufficient time for the food to cook. It is almost impossible to overcook food in a slow cooker, particularly when using the low or keep warm settings. Most recipes contained within this book, can be cooked on any one of the temperature settings, however cooking times will vary accordingly. Each recipe in this book will give specific instructions indicating the appropriate temperature setting as well as the suggested cooking times.

## Guide To Slow Cooking

Your favorite traditional recipes can be adapted easily by **halving** the amount of liquid and increasing the cooking time considerably. See the guide below for suggested cooking times and settings when adjusting your favorite recipes.

Traditional Recipe Time	Slow Cooker Recipe Time
15-30 minutes	4-6 hours on LOW
60 minutes	6-8 hours on LOW
1-3 hours	8-12 hours on LOW

**Note:** These times are approximate. Times can vary depending on ingredients and quantities in recipes.

All food should be cooked with the glass lid in place. Each time the lid is lifted, both the heat and moisture in the food are lost. Cooking times should thus be extended by approximately 30 minutes.

## Liquid Amounts

When food is cooking in your slow cooker, very little moisture boils away. To compensate this, it is advisable to halve the liquid content of traditional recipes. However, if after cooking, the liquid content is excessive, remove the lid and operate the slow cooker on the high setting for 30-45 minutes or until the liquid reduces by the desired amount.

## Simple Chicken Cacciatore

### **Ingredients:**

- 3 lbs boneless chicken breasts
- 1 small white onion, chopped
- 1 lb fresh mushrooms, quartered
- 2 cloves garlic, mined
- 1/4 cup flour
- 1/2 cup chicken broth
- 2 Tbsp tomato paste
- 1 14 1/2 oz whole, peeled tomatoes, drained
- 1 tsp dried basil leaves
- 1/2 tsp dried oregano leaves
- 1/2 tsp dried thyme leaves
- 2 Tbsp olive oil
- 1/2 tsp black pepper
- salt & pepper to taste

### **Directions:**

Layer onions on the bottom of the ceramic pot. Place the chicken breasts on top of the onions and then top the chicken with the remaining ingredients. Cover with glass lid and cook for 8 hours on Low setting or for 4 hours 30 minutes on High setting.

## Barbecued Ribs

### **Ingredients:**

- 1 1/2 lbs pork loin back ribs
- 1/4 cup packed brown sugar
- 1/2 tsp. pepper
- 1 Tbsp liquid smoke
- 2 garlic cloves, chopped
- 1/2 tsp. salt
- 1 small onion, sliced
- 1/4 cup cola
- 3/4 cups barbecue sauce

### **Directions:**

Spray inside of slow cooker with cooking spray. Remove inner skin from ribs. Mix brown sugar, pepper, liquid smoke, garlic and salt; rub mixture into ribs. Cut ribs into 4-inch pieces. Layer ribs and onion in slow cooker. Pour cola over ribs. Cover and cook on low heat setting 8 to 9 hours or until tender. Remove ribs from slow cooker. Drain and discard liquid. Pour barbecue sauce into shallow bowl. Dip ribs into sauce. Place ribs in slow cooker. Pour any remaining sauce over ribs. Cover and cook on low heat setting 1 hour.

## Fall Football Chili

### Ingredients:

- 3 1/2-4 lbs. coarsely ground beef
- 1 14 1/2 oz. can beef broth
- 3 Tbsp medium onion, finely chopped
- 3 tsp. instant beef bouillon
- 1 8oz can tomato sauce
- 2 Tbsp paprika
- 1/2 tsp. black pepper
- 4 Tbsp chili powder
- 1 Tbsp cumin
- 1/4 tsp. onion powder
- 1/4 tsp. salt
- 1/4 tsp. garlic powder
- 1/4 tsp. garlic salt
- 1/4 tsp. sugar
- 1 Tbsp lime juice
- 1 small package frozen corn, thawed (optional)
- sour cream, for topping
- chopped green onion, for topping
- 1/2 cup shredded cheese, for topping

### Directions:

Cook beef in a large skillet over medium heat, stirring to crumble the beef until it is browned. Drain. Place cooked beef, chopped onion, beef broth, tomato sauce, chili powder, paprika, cumin, two teaspoons of the beef bouillon, garlic powder, and black pepper in ceramic pot. Mix ingredients and cover with glass lid. Cook for 7 hours 15 minutes on Low setting or 3 hours 15 minutes on High setting. Stir in remaining beef bouillon, onion powder, salt, sugar and lime juice. Cover and cook for one more hour. Top with sour cream, green onions and cheese if desired.

## Classic Beef Stew

### Ingredients:

- 4 lbs. stewing beef, cut into 1-inch cubes
- 1/2 cup flour
- 1 tsp salt
- 1 tsp black pepper
- 3 cups beef broth
- 2 tsp Worcestershire sauce
- 2 cloves garlic, minced
- 2 bay leaves
- 2 tsp paprika
- 8 small potatoes, diced
- 4 small onions, diced
- 4 celery stalks, sliced

### Directions:

Brown beef in a large skillet over medium heat, stirring until all sides are brown. Add meat to ceramic pot. Sprinkle flour, salt and pepper over meat and stir to coat well. Add remaining ingredients and stir to mix well. Cover and cook on Low setting for 11 hours or on high for 5 hours 30 minutes. Stir thoroughly before serving.

## Stirring Food

Little or no stirring is required when using the low or keep warm setting. When using the high setting, stirring ensures even flavor distribution.

## Basic Cooking Time Guide

Heat Setting	Low	High
3-4 Lb. Chicken	6-8 Hours	3-4 Hours
3-4 Lb. Pot Roast	6-8 Hours	4-5 Hours
3 Qt. Beef Stew	8-10 Hours	4-5 Hours
3 Qt. Chili	8-10 Hours	4-5 Hours
3 Qt. Vegetable Soup	6-8 Hours	3-4 Hours

\*The cooking times given above should be used **ONLY** as a guide. It is recommended that a thermometer be used to check the temperature to ensure the food is completely cooked.

## Tips For Slow Cooking

- The cover of the slow cooker does not form a tight fit on the ceramic pot but should be centered on the ceramic pot for best results. **Do not remove the glass cover unnecessarily** - this will result in major heat loss. Do not cook without the glass cover in place.
- Stirring is not normally needed when using a slow cooker. However, if cooking on high, you may want to stir occasionally.
- Slow cooking retains most of the moisture in foods. If a recipe results in too much liquid at the end of the cooking time, remove glass cover, turn the control knob to high, and reduce the liquid by simmering. This will take 30-45 minutes.
- The slow cooker should be at least half-filled for best results.
- If cooking soups or stews, leave a 2-inch space between the top of the ceramic pot and the food so that the food may be allowed to simmer.

- Many recipes call for cooking all day. You can also prepare the recipe the night before by placing all ingredients in the ceramic pot, cover and refrigerate overnight. In the morning, simply place the ceramic pot in the slow cooker and select the time and temperature setting.
- Meat & Poultry require at least 7 to 8 hours on LOW. Do not use frozen meat in the slow cooker. Thaw any meat or poultry before slow cooking.
- Trim all visible fat from meat or poultry.
- Cook dried beans 1-2 hours on high setting, then add remaining ingredients, cook on low for the remaining time.
- When cooking curries and casseroles, richer, more intensive flavors will develop when the first stage is prepared by traditional methods, i.e. brown the onions, meat and spices first in a non-stick pan.

## DO's

- Handle the ceramic pot and glass lid with care.
- Use oven mitts when lifting the ceramic pot containing hot foods.
- Avoid extreme temperature changes in the ceramic pot or glass lid. For example, do not place into or under cold water while still hot.

## DO NOT's

- Use the ceramic pot if chipped or cracked.
- Operate the slow cooker without the ceramic pot in place.
- Place the hot ceramic pot onto a wet surface.
- Use frozen meats or foods in slow cooker. Always defrost them first.
- Place the glass lid in oven or microwave.

## NEVER

- Use abrasive cleansers or metal scouring pads when cleaning the ceramic pot.
- Place water or other liquids into the base of the slow cooker.
- Immerse the base, cord or plug of the slow cooker into water or any other liquid.
- Touch hot surfaces with bare hands.

## CLEANING & MAINTENANCE

**CAUTION:** Make sure that the unit is unplugged from the power source and the control button is on “Off” before cleaning.

- Always allow unit to cool before cleaning.
- Remove the ceramic pot and glass lid and wash in hot, soapy water using mild dishwashing detergent. Rinse and dry thoroughly.
- **Never** use abrasive cleansers or metal scouring pads to clean the ceramic pot or glass lid.
- To soften stubborn, cooked on foods, fill the ceramic pot with warm, soapy water and allow to soak. Remove by lightly scrubbing with a nylon kitchen brush.

- The ceramic pot and glass lid can be washed in the dishwasher. However care should be taken not to chip or crack the ceramic pot or glass lid.
- **Never** immerse the metal housing, cord or plug in water or any other liquid.
- Clean the metal housing only with a damp cloth. **DO NOT** immerse in water.
- When storing your slow cooker, loosely coil the power cord, don't wrap the cord around the unit.

## COOKING RECIPES

### Hot Spiced Cherry Cider

#### Ingredients:

- 4 quarts apple cider
- 4 cinnamon sticks
- 2 3 oz. package of orange flavored gelatin
- 2 3 oz. package of cranberry flavored gelatin

#### Directions:

Mix together the apple cider and cinnamon sticks in the Slow cooker. Heat on High for 3 hours. Stir in cranberry & orange flavored gelatin. Keep on High 1 more hour and allow gelatin to dissolve. Turn to Low to keep warm. Serve directly from the Slow Cooker.

### Warm Spinach Artichoke Dip

#### Ingredients:

- 2 8 oz. packages of softened cream cheese
- 3/4 cup light cream
- 1/3 cup grated Parmesan cheese
- 1/2 tsp. garlic powder
- 2 8 oz. box frozen cut leaf spinach, thawed and well drained
- 2 12 oz jar or can quartered artichoke hearts, rinsed
- 2/3 cup shredded Monterey Jack cheese
- 1 cup prepared salsa mixture, canned or fresh

#### Directions:

In a food processor, process the cream cheese, cream, Parmesan cheese and garlic powder until smooth and creamy. Add the spinach and process until thoroughly mixed. Add the artichokes and process until coarsely chopped. Spoon the mixture in to the Slow Cooker. Cover and cook on High for 1 to 1.5 hours until hot in the center. Sprinkle the top evenly with Monterey Jack cheese and spoon the salsa in a ring around the inside edges of the Stoneware. Cover and continue heating on High 15 minutes longer, or until the cheese is melted.

### Traditional Baked Beans

#### Ingredients:

- 6 cans (28 ounces each) vegetarian baked beans, drained
- 2 medium onion, chopped (1 cup)
- 1 1/3 cup barbecue sauce
- 1 cup packed brown sugar
- 4 Tbsp ground mustard

#### Directions:

Mix all ingredients. Cover and cook on low heat setting 4 to 5 hours (or high heat setting 2 hours to 2 hours 30 minutes) or until desired consistency.