

...the broadest narrowband money can buy



Operating manual



Wideband modems – PROFI MX160

version 1.3
1/12/2009

Table of Contents

Introduction	5
1. Radio modem MX160	6
2. Description of Radiomodem MX160	7
2.1. Radio part	7
2.2. Modem part	7
2.3. Supplying	7
2.4. Radio Modem Assembly	7
3. Connectors	9
3.1. Antenna	9
3.2. Serial Interface	9
3.3. Ethernet	11
3.4. Analog and Digital Inputs and Outputs	12
3.5. M-BUS module	14
3.6. GPS Module	15
3.7. T-port	17
3.8. Supply Connector	19
3.9. Information LED	19
3.10. Service Connector	19
3.11. View of Radio Modem	21
4. Table of Technical Parameters	22
5. Dimensional Diagram and Labeling Modems	24
6. Condition for MX160	25
6.1. Important Warning	25
6.2. Conditions of Liability for Defects and Instructions for Safe Operation of Equipment.	25
6.3. Product Conformity	25
6.4. Limitations of Use	28

List of Figures

1. Radio modem MX160 with Cannon connectors	5
2. Radio modem MR160 with screw clamps, MR300 with Cannon connectors and MR400 with Cannon connectors	5
3.1. RS232 DSUB9 female	9
3.2. Data cable RS485 connections	10
3.3. Labelling of serial interface terminals	11
3.4. RJ-45F	12
3.5. Wiring diagrams for analog and digital inputs and outputs	12
3.6. Description of analog and digital inputs and outputs	13
3.7. Examples of wiring analog inputs and outputs	14
3.8. Description of S-BUS module connectors	15
3.9. GPS modul on 2 nd slot of MR400 modem	17
3.10. T-port module on the 2nd slot of the modem	18
3.11. RJ-45F connector	19
3.12. Power connector & information LED	19
3.13. Service connector	20
3.14. Service cable connector connections	20
3.15. View of radio modem — description of connectors, model with DSUB (Canon) connectors and with terminals	21
5.1. Mounting dimensions of the radiomodem	24
6.1. Consistency declaration	27

List of Tables

3.1. Table of data connector RS232 connections	9
3.2. Table of data connector RS422 connections	10
3.3. Table for distinguishing LEDs for RxD and TxD by colour	11
3.4. Table of Ethernet to cable connector connections	12
3.5. Table of digital and analog input and output parameters	13
3.6. M-BUS module parameters	15
3.7. Key to M-BUS module LEDs	15
3.8. Connection of data cable	16
3.9. Meaning of GPS module LEDs	16
3.10. GPS module parameters	17
3.11. T-port module parameters	18
3.12. Key to T-port module LEDs	19
3.13. Table of service connector connections	20
3.14. Slot options	21
4.1. Table of technical parameters MX160	22
4.2. Standards complied	22
4.3. Standards complied for Railway Safety Appliance Standards Regulations	23

Introduction

This operator manual serves as the primary document for familiarising users with the parameters of the radio modem MX160, its properties, modifications and with the parameters of connecting parts. This controller is part of the MORSE system, is fully compatible with other modems, and because it is derived from previously developed types it has similar mechanical parameters to them, as well as all interfaces, the modem part and firmware. For this reason modem MR400 images are often used in other parts of the manual. In order to master all the functions of the radio modem and the MORSE system you should refer to other documents.



Fig. 1: Radio modem MX160 with Cannon connectors



Fig. 2: Radio modem MR160 with screw clamps, MR300 with Cannon connectors and MR400 with Cannon connectors

1. Radio modem MX160

MX160 is conceptually new radio modems designed for transmitting data in the VHF and UHF bands. The radio modem uses 2-state GMSK modulation providing for a maximum signalling rate of 133 kbit/s.

The radio modem is of modular design with one to four standard RS232 ports (an RS422 or RS485 port can be used in place of two of them) available to the user. The configuration can be extended by an Ethernet interface and also by a module with analog and digital inputs/outputs and GPS modul. It is generally manufactured with two analog inputs and outputs and with two digital inputs and outputs.

The radio data transceiver module can be configured to a random frequency of the transmitter and receiver in the 3.2 MHz frequency range in a 25 kHz channel raster. The output and input working frequencies are mutually independent and are derived from the frequencies of four phase-hung systems programmed by the transceiver microprocessor. Channel settings are stored in the transceiver FLASH memory and the FLASH memory module of the modem whose communication processor controls the operation of the transceiver microprocessor. The power of the radio modem transmitter is digitally set in sixteen steps from 0.1 to 25 W.

The design and construction of this device allows for long-term loading and for this reason it is primarily determined for continuously running applications.

Software control is compatible with the operation and configuration of the other radio modems of the MORSE system. A description of software control and configuration of the radio modems is available in publications describing MORSE Firmware.



Important

The radio modem is equipment which can only be operated in the state on the basis of Permission to operate transmitting radio stations issued by the Department of Frequency Spectrum Management at the national Telecommunication Office.

2. Description of Radiomodem MX160

2.1. Radio part

The architecture of MX160 radio modems resolves most of the requirements placed on a top quality user friendly radio modem with a very short switching time between receiving and transmitting. Frequency synthesis enables operation on any random channel from a given frequency band. The operation of the radio data transceiver module is controlled and diagnosed by the micro-controller. The receiving part of the radio modem works with double mixing. Concentrated selectivity is divided between both intermediate frequency levels. The first filter carries out basic channel pre-selection up until attenuation which ensures the linear function of the following second mixer and intermediate frequency amplifier. The second filter of concentrated selectivity has an attenuation characteristic necessary for channel selection in the used channel spacing of 200 kHz. Logic circuits, switching stations between modes of receiving and transmitting, have high noise immunity and switch respective blocks sequentially. This minimises most transient parasite states and optimises bandwidth during switching. Station block modes are logically tied and switching of the station to transmitting mode is tied to the frequency synthesiser lock, the internal temperature of the radio transceiver module and the value of the supply voltage.

2.2. Modem part

The control microcomputer has 4 MB of FLASH memory and 16 MB of RAM memory available. The battery, real time backup supply, detector of supply voltage failure and watch dog circuits belong amongst the other circuits of this block. If there is a supply voltage failure the fact is recorded into memory with the respective time data thanks to the charge stored in electrolytic capacitors. The user therefore has information available about the time and duration of possible faults caused by power failures. It is possible to connect equipment with signalling rates up to 115.2 kbit/s to the modem via the RS232 data interface. RS232 interface converters are protected against overvoltage with TRANSIL elements. A lithium battery is used for backing up in the modem part.



Note

Owing to the use of lithium batteries in the modem part it is not recommended to store them for a period of longer than 2 years.

2.3. Supplying

The radiomodem is supplied by the DC current 13.8 V. The consumption in the quiet state is from 350 to 500 mA according to module used, the consumption at transmitting is up to 2 A. The modem can be set in the SLEEP mode when the consumption drops down to 2.5 mA. The return in the active mode can be done by the signal inputting on the serial port or after a preset time.

2.4. Radio Modem Assembly

Radio modems MX160 are special devices which require skilled assembly. All supplied equipment is assembled by RACOM at the user's site. For subsequent maintenance RACOM specially trains the user's skilled staff and as an additional aid provides them with Operating regulations for radio data networks and MORSE Firmware – Documentation.



Important

CAUTION! Danger of explosion upon replacing the incorrect type of battery. Follow the manufacturers instructions for handling used batteries.

3. Connectors

3.1. Antenna

The radio modem is fitted with two SMA type connectors for connecting an antenna. The connector labelled Rx is for the receiver, and Tx for the transmitter (up to 25 W). Use the corresponding type of connector with matched impedance as the mate. We recommend an RG158 cable for the serial lead.



Important

The radio modem cannot be connected to the power supply without the antenna connected (or corresponding artificial load). Otherwise this could lead to damage to the radio part of the modem.

3.2. Serial Interface

The radio modem can be equipped with serial ports RS232 or RS422/485, the ports can be optical isolated. According to the configuration of the radio modem it is possible to use a terminal block or DSUB 9 (Canon) connectors for connecting data cables via the serial interface. See Chapter *Labelling modems*.

3.2.1. RS232, RS422 and RS485 Connectors

a) Table of data connector RS232 connections for Radio modems

Tab. 3.1: Table of data connector RS232 connections

RS232 signal	Screw terminals	DSUB9F pin
CTS	1	8
RTS	2	7
RxD	3	2
TxD	4	3
GND	5	5
DTR		4
DSR		6
CD		1
RI		9



Fig. 3.1: RS232 DSUB9 female

b) Table of data connector RS422 connections for Radio modems

Tab. 3.2: Table of data connector RS422 connections

RS422 signal	Screw terminals	DSUB9F pin
TxD-	1	7
TxD+	2	3
RxD-	3	8
RxD+	4	2
GND	5	5

c) Connection diagram of data cable RS485 for Radio modems

When you are connecting RS485, your “A” has to be connected to TxD+ and RxD+ simultaneously and “B” to TxD- and RxD- simultaneously.

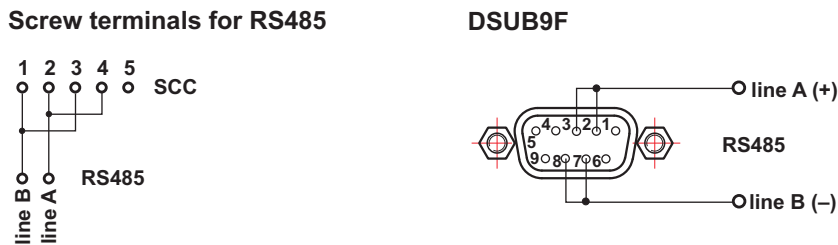

Fig. 3.2: Data cable RS485 connections



Note

For data connector RS485 connection see *Table of data connector RS422 connections*.



Important

For making data cables for connecting the user’s terminal equipment to the modem’s serial port we recommend using a shielded cable, particularly in an industrial environment, and connecting the shielding to GND (pin No. 5). When using a multi-core cable all free conductors should be connected to pin No. 5. In the case of a galvanically separate port for RS485 (RS422) only ground one side of the data cable. We recommend using only the necessary minimum length for data cables.

3.2.2. Distinguishing Data Modules by Colour

For RS232 RxD is the output from the radio modem (approx. -8V when inactive) and TxD is the input to the radio modem (according to the RS 232 standard). Hardware versions of the interface can be distinguished according to the colours of LED diodes next to the connector.

Tab. 3.3: Table for distinguishing LEDs for RxD and TxD by colour

Type of interface	Colour (RxD / TxD)
RS232	red / green
RS232 opt. separated	orange / green
RS422/485 opt. separated	orange / yellow

3.2.3. Labelling of SCC terminals

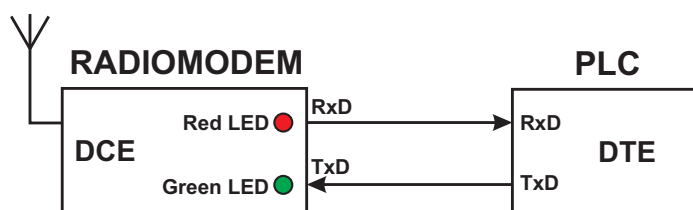

Fig. 3.3: Labelling of serial interface terminals

The SCC ports of the radio modem are DCE type devices. Based on standards the receiver terminal RxD of the connected DTE device is connected to the transmitting terminal of the modem's SCC port which is also labelled RxD. Similarly the red LED indicating transmission from SCC is labelled RxD.

3.3. Ethernet

- Connector RJ-45 for Ethernet 10BaseT and 100BaseT corresponds to the EIA TIA T568B standard.
- Informative LED diodes indicate:
 - Tx – output from ETH channel
 - Rx – input to ETH channel
 - 100 – if lit the 100Base-TX net is indicated otherwise is 10Base-T
 - LINK – indicates correctly connected link
 - F.D. – indicates full duplex operation
- The direct cable serves for connecting to the Ethernet network via the hub (repeater) or switch-hub (router).
- A crossed cable serves for connecting only two devices - MR400-MC100, MR400-PC, etc.

The following table contains connector connections and colours of conductors. For the crossed cable the order of conductors on one side is the same as for the direct cable.

Tab. 3.4: Table of Ethernet to cable connector connections

PIN	Signal	Direct cable	Crossed cable
1	TX+	white - orange	white - green
2	TX-	orange	green
3	RX+	white - green	white - orange
4	—	blue	blue
5	—	white - blue	white - blue
6	Rx-	green	orange
7	—	white - brown	white - brown
8	—	brown	brown

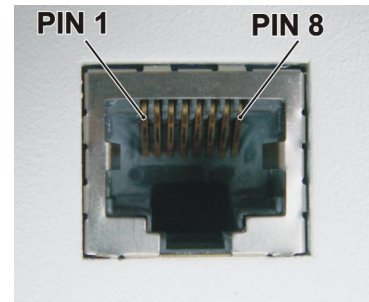

Fig. 3.4: RJ-45F

3.4. Analog and Digital Inputs and Outputs

The board of analog and digital inputs and outputs (ADIO module) is designed for :

- creating 20 mA current loops
- switching loads supplied with DC and AC current
- scanning digital signals

Each functional group of terminals is galvanically separated from the rest of the device as shown on the internal layout diagram for the ADIO module on the image below:

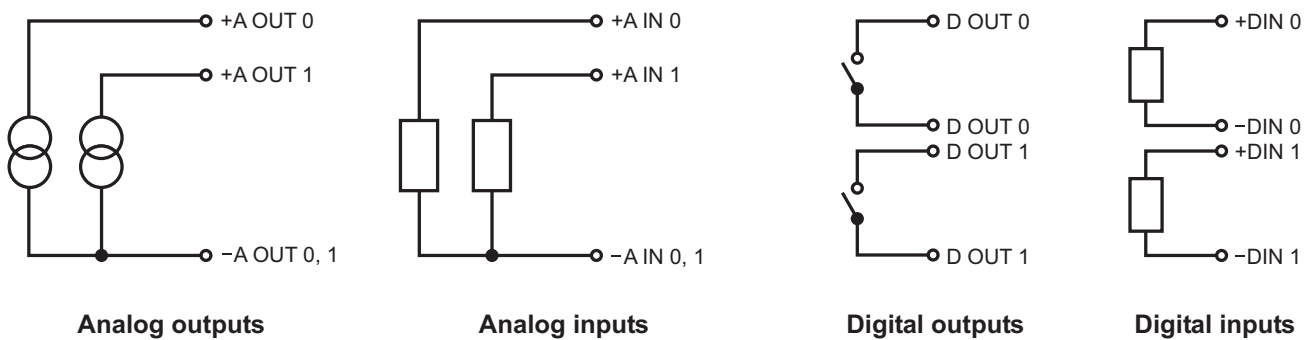

Fig. 3.5: Wiring diagrams for analog and digital inputs and outputs

3.4.1. Labelling

Individual terminals of terminal blocks are labelled:

- Connector A OUT - analog outputs
- Connector A IN - analog inputs
- Connector D OUT - digital outputs
- Connector D IN - digital inputs

Terminal UP this clamps pair is not used

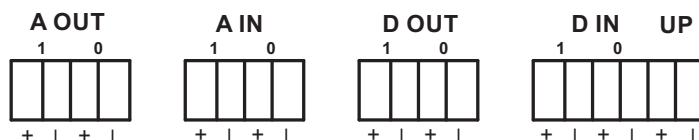

Fig. 3.6: Description of analog and digital inputs and outputs

3.4.2. Parameters

Tab. 3.5: Table of digital and analog input and output parameters

2 × optically separated digital output	<ul style="list-style-type: none"> • bipolar SSR switch design • voltage for supplying load max. 30 V DC, 24 V AC • switched current typically 300 mA • resistance in on state max. 1 Ω • protection against current overload in on state • protection against overvoltage in off state 	passive
2 × optically separated digital input	<ul style="list-style-type: none"> • passive optical element design • input voltage 0–2,3 V will be evaluated as log. 0 • input voltage 2–30 V will be evaluated as log. 1 • max. value of input voltage 30 V 	passive
2 × optically separated analog output	<ul style="list-style-type: none"> • current source 4–20 mA • load resistance max. 250 Ω • settings accuracy better than 0.1 % 	active
2 × optically separated analog input	<ul style="list-style-type: none"> • sensitivity 0–20 mA (or after sw configuration 4–20 mA) • accuracy of measured values better than 0.1 % • input resistance 60 Ω • no protection against current overload • max. value of input current 50 mA 	passive

Analog inputs 0 and 1 have connected terminals - (minus), which are galvanically separated from the modem GND.

Analog outputs 0 and 1 have connected terminals - (minus), which are galvanically separated from the modem GND.

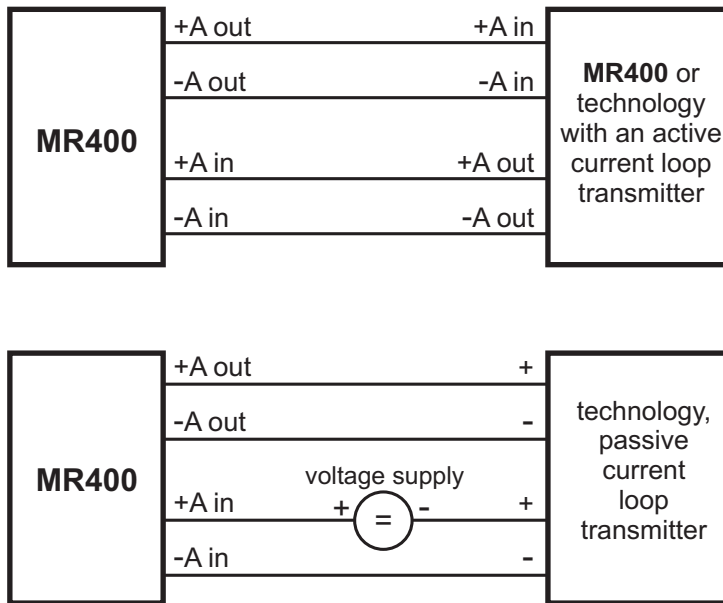

Fig. 3.7: Examples of wiring analog inputs and outputs

The MR400 radio modem used in the diagram showing examples of wiring can, of course, be replaced by any MORSE system modem. (e.g. MD160, MX 160, MWxxx, MRxxx, MC100, ...)

3.5. M-BUS module

(Meter-Bus)

Use

The M-BUS board serves as the MASTER interface of the physical layer of the M-BUS for the application of data collection from meters regulating the consumption of various types of media (water, gas, heat, etc.).

A M-BUS module can be positioned in the first or second slot of optional modules, see section Section 3.11, "View of Radio Modem". (For MG100 only in the first slot.) The second slot is recommended because when using slot 1 you first need to disconnect it in the modem's service mode, see section Section 3.10, "Service Connector".

For the correct operation of the module it needs to be configured to the proper SCC in menu `SPe` using `Setr`:

```
dia(g) mode : NORM
pr(o)toCol : L&G 870-5-2 IEC
```

**Note**

For configuration of the menu using program Setr see „MORSE firmware documentation¹“

A supply voltage can be applied to the board via the MR400 supply connector. In this case simply connect a wire with a positive voltage. When supplying from an external power source both leads need to be connected.

Tab. 3.6: M-BUS module parameters

Communication rate	300–9600 bps
Number of SLAVE meters	1–5
Galvanic separation	yes
Protection and indication of a s/c on the bus	yes
Power supply	external, 11–14 V/100 mA
Max. capacity of lead	100 nF/9600 bps, 1000 nF/300 bps

**Tip**

A supply voltage can be applied to the board via the MR400 supply connector. In this case simply connect a wire with a positive voltage. When supplying from an external power source both leads need to be connected.

Module connectors

- supply connector – terminals
- M-BUS – terminals

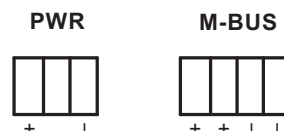
**Key to LED colours***Fig. 3.8: Description of S-BUS module connectors***Tab. 3.7: Key to M-BUS module LEDs**

red	Tx – transmitting data to M-BUS
orange	Rx – receiving data from M-BUS
yellow	OVL – overloading or s/c on M-BUS

3.6. GPS Module

A GPS module can be positioned in the first or second slot of optional modules, see section Section 3.11, “View of Radio Modem”. (For MG100 only in the first slot.) The second slot is recommended because when using slot 1 you first need to disconnect it in the modem’s service mode, see section Section 3.10, “Service Connector”. You can find further detailed information on the module manufacturer’s web pages².

GPS module connectors

- antenna connector – SMA female – marked **ANT**

¹ <https://www.racom.eu/cz/support/firmware/mr400/index.html>

² <http://www.u-blox.com/products/modules.html>

- data connector – DSUB9 (Canon) – marked **NMEA**

Antenna connector for an active antenna – the antenna supply to the antenna connector is short-circuit proof

Tab. 3.8: Connection of data cable

DSUB9F pin	RS232 signal
1	+3,3 V through 10 k resistor
2	data NMEA output
3	see Note
4	input ALARM 0 (from sw v. 8.05)
5	GND
6	output 1 PPS (pulse per second)
7	input ALARM 1
8	see Note
9	unwired



Note

- Inputs ALARM 0, 1 are passive, a positive 3-15 V voltage should be applied for accepting functions. For the contact activation can be connect the positive potential from pin No. 1.
- Pin No. 3 becomes the input for configuration data, if we connect pin No. 8 to GND.
- The behaviour of time pulses at pin No. 6 (default)

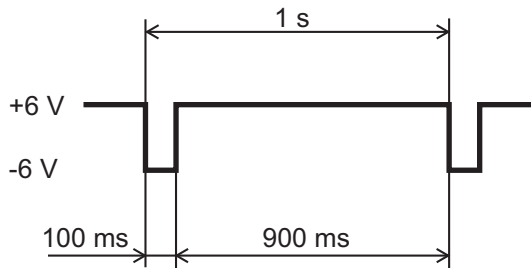

Meaning of LED colours

Tab. 3.9: Meaning of GPS module LEDs

red	TP – Time Pulse
green	St – Status (in progress)

The GPS is providing the correct data if the red LED is flashing to the rhythm of time pulses (typically 1 s).



Fig. 3.9: GPS modul on 2nd slot of MR400 modem

Tab. 3.10: GPS module parameters

Receiver type	16 channel, L1 frequency, C/A code
Location data updating	max. 4 times a sec., typically 1 s
Accuracy	position 2,5 m, SBAS 2,0 m
Start-up times	hot start < 3,5 s
	warm start 33 s
	cold start 34 s
	aided start 5 s
Timing accuracy	RMS 50 ns, 99 % < 100 ns
Protocol	NMEA
Power consumption (for 3 V)	< 20 mA including antenna
Signalling rate of module (SPe menu)	9 600 bps



Note

The communication protocol, data rate, period of time pulses, and other parameters can be configured in software, see „MORSE firmware dokumentation³“

3.7. T-port

(Ethernet to serial)

Use

The Ethernet interface is mounted with a standard RJ45/STP connector. This interface is an Ethernet (TCP, UDP) to RS232 serial interface converter.

The module automatically set communication to a speed of 10 or 100 Mbit/s according to the speed of the network to which it is connected.

³ <https://www.racom.eu/eng/support/firmware/mr400/index.html>

The T-port module can be positioned in the first or second optional module slot, see section Section 3.11, “View of Radio Modem”. (Or only in the first slot for MG100 modems.) The second slot is recommended because when using slot 1 you need to take into consideration the fact that it needs disconnecting when the modem is in service mode. For more detailed information see section Section 3.10, “Service Connector”.

T-port parameters are set up for communication with attached devices using a web browser. If the T-port IP address is unknown it can be found using program *DigiConf* from Digi⁴.

Attached devices send TCP/UDP frames from which data packets are generated after unpacking in T-port. Based on the format of these packets a suitable serial link protocol can be selected and they can be configured on the SCC using Setr. The standard setting for configuration parameters is 9600, 8 N 1.



Fig. 3.10: T-port module on the 2nd slot of the modem

Tab. 3.11: T-port module parameters

Communication speed	9600 bps
Power supply	internal
Consumption at 13.8 V	without ETH – 60 mA
	with ETH – 80 mA

⁴ <http://www.digi.com>

Module connectors

- T-port bus – RJ45/STP

Key to LED colours

Tab. 3.12: Key to T-port module LEDs

red	LINK – ETH link integrity
green	Act – network active

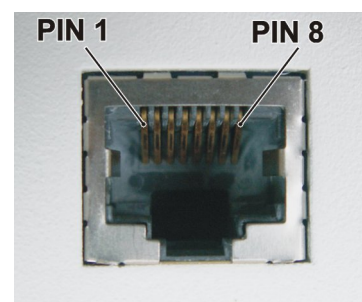

Fig. 3.11: RJ-45F connector

A description of connector wiring is in chapter ???.

3.8. Supply Connector

Terminals of this connector are labelled in the standard manner. Only DC voltage in the range from 10.8 to 15.6 V can be connected. Connecting higher voltage may damage the radio modem.

Terminal PI (power indicator) - if the radio modem is fed from the MS2000 power supply information about supply method from source clamp MAIN PWR OFF can be lead:

- level TTL1 or unconnected clamp - network supply
- level TTL0 or grounded clamp - battery supply



Fig. 3.12: Power connector & information LED

Maximal supply cable length is 3 m.

3.9. Information LED

Information LED diodes next to the supply connector:

- RF Tx — radio modem transmits RF frequency into antenna
- RS SYNC — radio modem received message header which was determined for it
- Three following LED (signal strength):

ON	ON	ON	RSS -85dBm and stronger
OFF	ON	ON	RSS -85 až -95dBm
OFF	OFF	ON	RSS -95 až -115dBm
OFF	OFF	OFF	RSS -115dBm and weaker

- POWER ON — radio modem is correctly supplied

3.10. Service Connector

The service connector RJ-12 serves for short-term connections of the service cable during local adjustment of radio modem parameters. Upon attaching the connector (connecting to the RS232 link (RxD, TxD, GND)) the radio modem automatically switches to service mode and the module slot 1 disconnects. Slots numbering see section Section 3.11, “View of Radio Modem”.

Tab. 3.13: Table of service connector connections

1	AF_OUT	output of modulation from RF part of radiomodem
2	SER_RxD	RS232 RxD output from modem
3	SER_TxD	RS232 TxD input to modem
4	MOD_BSB	input modulation to RF part of radiomodem
5	GND	ground
6	PTT	keying of TX carrier waves for service purposes



Fig. 3.13: Service connector



Important

ATTENTION! The service mode is not suitable for normal operation

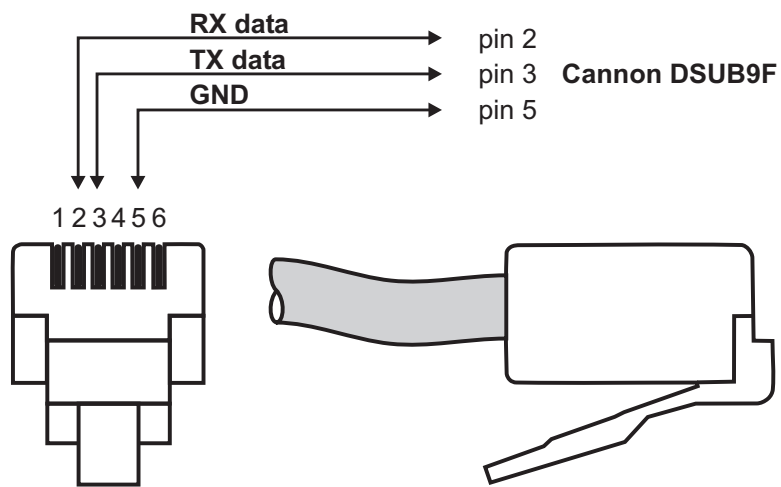

Fig. 3.14: Service cable connector connections

3.11. View of Radio Modem

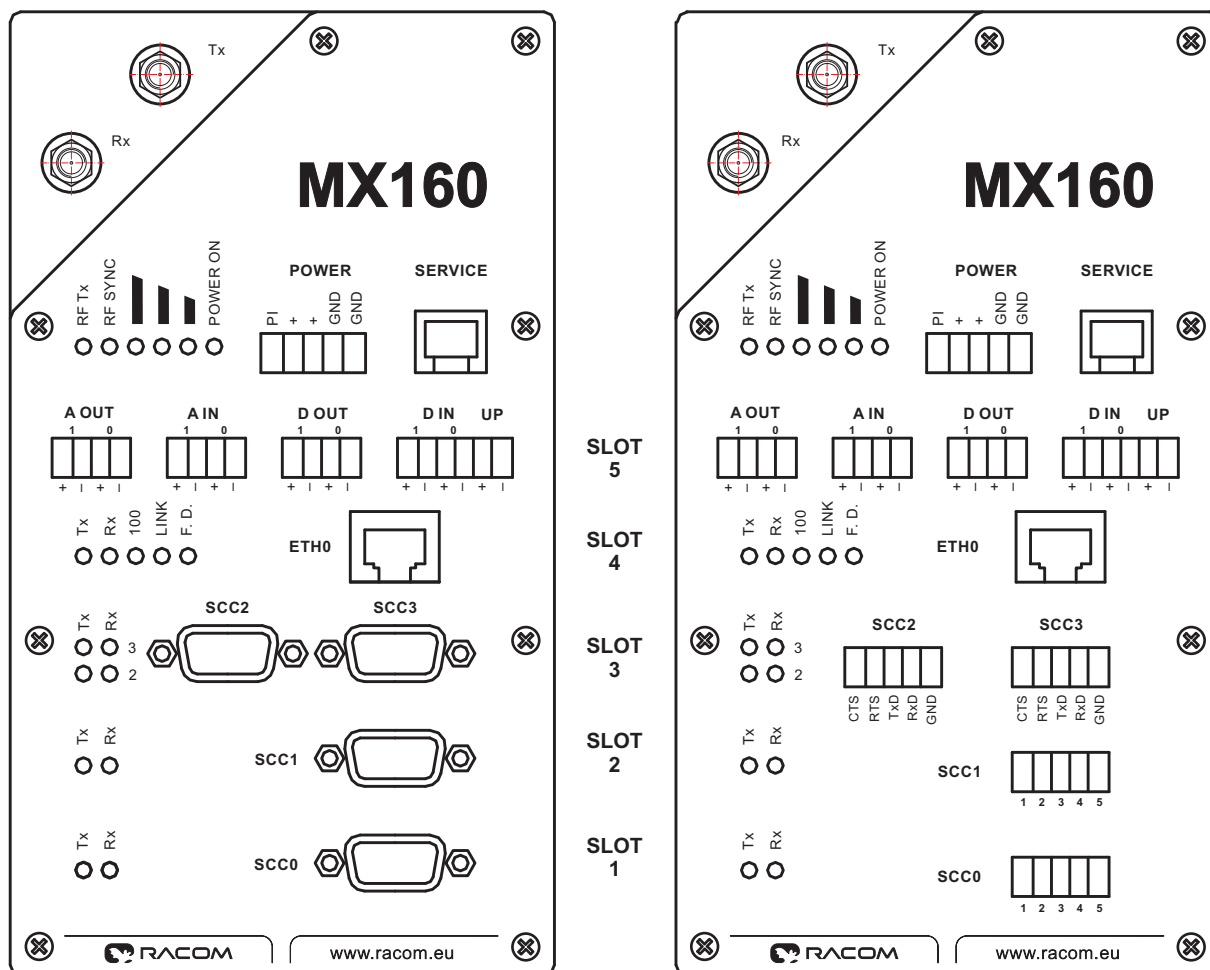

Fig. 3.15: View of radio modem — description of connectors, model with DSUB (Canon) connectors and with terminals

Tab. 3.14: Slot options

Optional modules	
slot 5	ADIO (analog and digital inputs and outputs)
slot 4	Ethernet 10/100 Mbps
slot 3	2×RS232
slot 2	RS232 or galv.sep. RS232 or RS422/RS485 or GPS or M-BUS or TPORT
slot 1	RS232 or galv.sep. RS232 or RS422 or GPS or M-BUS or TPORT

4. Table of Technical Parameters

Tab. 4.1: Table of technical parameters MX160

Frequency range	Tx: 154,725–159,725 MHz/159,325–164,325 MHz
	Rx: 159,325–164,325 MHz/154,725–159,725 MHz
Channel spacing	200 kHz
Means of setting working frequency	software in range +3.2 MHz from base frequency
Receiver sensitivity for BER 10^{-3}	better than -104 dBm
Software adjustable output power	0.1–25 W
Max. modulation rate for transmitting	133 kbit/s in 200 kHz channel
Optional modules	
	slot 5 ADIO (analog and digital inputs and outputs)
	slot 4 Ethernet 10/100 Mbps
	slot 3 2×RS232
	slot 2 RS232 or galv.sep. RS232 or RS422/RS485 or GPS or M-BUS or TPORT
	slot 1 RS232 or galv.sep. RS232 or RS422 or GPS or M-BUS or TPORT
Antenna connector	SMA + SMA
MTBF(Mean Time Between Failure)	> 100 000 hours
Supply nominal voltage	13.8 V
Supply voltage range	10.8–15.6 V
Idle consumption (Rx) *	420 mA + modules: (Eth. 30 mA, ADIO 50 mA, GPS 15 mA, SCC 5 mA, M-BUS <100 mA, T-port 80 mA)
Transmission consumption (Tx) *	5.5 A / 25 W
Consumption in SLEEP mode	2.5 mA
Operating range of temperature	-25 to +55 °C
Storage range of temperature	-40 to +85 °C
Mechanical dimensions	208×108×63 mm (71 mm DIN rail including)
	184×108×63 mm (short version)
Spacing of fastening holes	198×65 mm, ø 4.8 mm
Weight	1.3 kg

* Approximate values dependent on frequency and modem type.

Tab. 4.2: Standards complied

EMC (Electromagnetic Compatibility)	ETSI EN 301 489-5 V 1.3.1
Radio parameters	ETSI EN 300 908-9 V 1.1.1 (2002-01), ETSI EN 300 113-1 V 1.5.1 (2003-09)
Electrical safety	CSN EN 60 950:2001
Wheeled vehicle usage	UN Regulation No.10 (EHK No.10)

Tab. 4.3: Standards complied for Railway Safety Appliance Standards Regulations

Electronic appliances in railway vehicles	CSN EN 50155 ed. 2 nd : 2002. art. 10.2.8.2 CSN EN 50121 art. 7: tab. 3 and 4
EMC (Electromagnetic Compatibility)	CSN EN 50121-3-2 art. 8
Vibrations and beats	CSN EN 61373

5. Dimensional Diagram and Labeling Modems

Dimensional Diagram

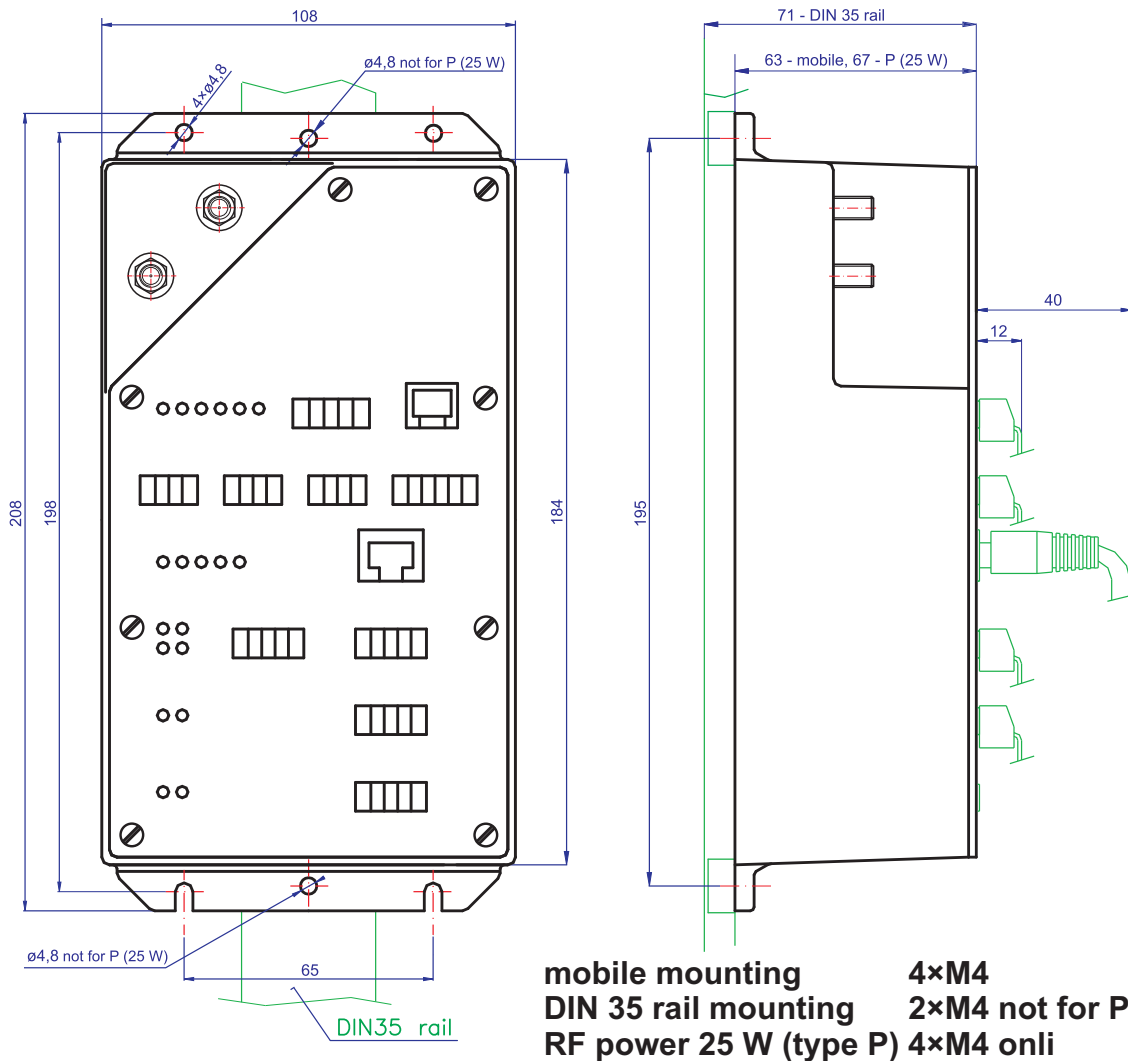

Fig. 5.1: Mounting dimensions of the radiomodem

The modem can be fastened by four screws M4 (for mobile application especially) or by the mounting rail DIN35 (stable applications). The flexile clamps mounted in the central holes are used for fastening on the DIN35 rail.

For the high-performance P model the modem is mounted on the back wall to ensure sufficient cooling of the modem. In this case 4x M4 screws are used for mounting purposes. There are no centre holes in the P version for attachment to a DIN rail.

Labelling Radio Modems

is described in next table:

6. Condition for MX160

6.1. Important Warning

RACOM s. r. o. (hereinafter referred to as RACOM) is the exclusive owner of all rights to this operator manual. All rights reserved. Any duplication of this manual in any way, shape or form, or translation to any other language (without the prior written consent of the owner of the rights) is strictly forbidden. RACOM retains the right to make changes to the technical specification or functions of this product or to terminate production of this product, or to terminate service support of this product without advance written notice to the customer. RACOM firmware is available free of charge. Source code is the property of RACOM and is not available to any user. Any commercial use of the software with this licence is strictly forbidden. Changes to software and documentation are forbidden. RACOM firmware is released with the intention that it will be useful, however without any specific guarantees.

Under no circumstances is the Racom or any other company or person responsible for incidental, accidental or related damage arising as a result of the use of this product. The manufacturer shall not provide the user with any form of guarantee containing assurance of the suitability and applicability for its application. RACOM products are not developed, designed or tested for use in equipment which directly affects the health and life functions of humans or animals and neither as part of other important equipment, and RACOM does not provide a guarantee if company products are used in such equipment.

6.2. Conditions of Liability for Defects and Instructions for Safe Operation of Equipment.

Please read these safety instructions carefully before using the product:

- Liability for defects does not apply to any product that has been used in a manner which conflicts with the instructions contained in this operator manual, or if the case in which the radio modem is located has been opened, or if the equipment has been tampered with.
- The radio modem can only be operated on frequencies stipulated by the body authorised by the radio operation administration in the respective country and cannot exceed the maximum permitted output power. RACOM is not responsible for products used in an unauthorised way.
- Equipment mentioned in this operator manual may only be used in accordance with instructions contained in this manual. Error-free and safe operation of this equipment is only guaranteed if this equipment is transported, stored, operated and controlled in the proper manner. The same applies to equipment maintenance.
- In order to prevent damage to the radio modem and other terminal equipment the supply must always be disconnected upon connecting or disconnecting the cable to the radio modem data interface. It is necessary to ensure that connected equipment has been grounded to the same potential. Before connecting the supply cable the output source voltage should be disconnected.
- Only undermentioned manufacturer is entitled to repair any devices.

6.3. Product Conformity

Hereby, RACOM s. r. o., declares that this MX160 radio modem is in compliance with the essential requirements and other relevant provisions of Directive 1999/5/EC. This equipment therefore bears the CE marking. The warning exclamation mark in the circle marks the radio modem as class 2

equipment denoting radio equipment with possible limitations or with requirements on authorisation to use radio equipment in certain countries.

CE 1355 !

...the broadest narrowband money can buy



Declaration of Conformity – MX160

- in accordance with **1999/5/EC** Directive of the European Parliament and of the Council of 9th of March 1999 on radio equipment and telecommunications terminal equipment and the mutual recognition of their conformity.

Manufacturer: RACOM
Address: Mirova 1283, 592 31 Nove Mesto na Morave, Czech Republic
VAT: 46343423
Product: MX160
Purpose of use: Radio modem

CE 1355 ⓘ

Notified Body Opinion:

According to: European Union Directive 1999/5/EC – ANNEX IV
 Document No.: 00007/171/5/2006
 Issued by: Vyskumny ustav spojov Banska Bystrica, Slovakia on 6th of February 2006
 Notified Body: No. 1355

We, the manufacturer of the above mentioned product, hereby declare that:

- all essential radio test suites have been carried out and that the above named product is in conformity to all the essential requirements of the European Union directive **1999/5/EC – ANNEX IV** for equipment working in mode listen before transmit (the technical documentation relevant to the abovementioned equipment can be made available for inspection on application to manufacturer);
- the above named product is safe on condition of usage mentioned in the operating manual.

The Declaration of Conformity is based on the following documents:

Test specification:	Document No.:	Date of issue:	Laboratory:
RA1212	ETSI EN 300 113-1 V1.5.1, ETSI EN 300 908-9 V1.1.1	19.12. 2006	TESTCOM Praha
17/04	ETSI EN 301 489-5 V1.2.1	26.02. 2004	TESTCOM Praha
29/608/2006	ETSI EN 301 489-5 V1.3.1	24.04. 2006	VÚS B. Bystrica
85/608/2006	ETSI EN 301 489-1 V1.4.1	05.12. 2004	VÚS B. Bystrica
EB1265	EN 60950	10.03. 2004	TESTCOM Praha

Nove Mesto na Morave, 14th of July 2006
 Jiri Hruska, Managing Director

RACOM s.r.o. • Mirova 1283 • 592 31 Nove Mesto na Morave • Czech Republic
 Tel.: +420 565 659 511 • Fax: +420 565 659 512 • E-mail: racom@racom.eu

www.racom.eu

Fig. 6.1: Consistency declaration

6.4. Limitations of Use

The MX160 radio modem has been developed for the frequency range 154 to 164 MHz. Specific frequencies are used for each country or region. A radio modem user must keep in mind that this radio device cannot be operated without the permission of the respective local radio spectrum administrator who provides a specific frequency for use and issues the appropriate permission for this. The MR400 radio modem can be used in the following countries either based on a general permission agreement or on frequencies requiring a licence for operation. Country codes according to ISO 3166-1-Alpha-2 standard: AT, AU, BE, BR, BG, CA, HR, CZ, CY, DK, EE, FI, FR, DE, GR, HK, HU, IS, IE, IT, LV, LT, LU, MY, NL, NO, PL, RO, SG, SI, ZA, ES, SE, CH, GB and US. The MX 160 is only licensed for use in Norway at the present time.