



M157305H

Proven Performance

K-BAR Industries, Faribault, MN, 55021

ITEM NUMBER: 157305,306,307,308			
SERIAL NUMBER: _____			
HP: _____	Volts: _____	Amp: _____	Ph: _____
RPM: _____	PSI: _____	GPM: _____	Nozzle Size: _____
Pump: _____		Hose: _____ Lance: _____	
Max. Discharge Temperature: _____			

Installation, Operation, and Maintenance Manual

HOT WATER PRESSURE WASHER:
Cleans dirty surfaces with high-pressure hot water.

To the Owner:

Thank you for purchasing a Northstar hot water pressure washer. Your machine is designed for long life, dependability, and the top performance you demand! Take time now to read through this manual so you will better understand the machine's operation, maintenance and safety precautions. Everyone who operates this machine must read and understand this manual. The time you take now will prolong your machine's life and prepare you for its safe operation. Enjoy the exceptional performance of your Northstar hot water pressure washer, the industry leader! The manufacturer reserves the right to make improvements in design and/or changes in specifications at any time without incurring any obligation to install them on units previously sold.

Quick Facts

Pump Oil	Pump is shipped with oil. Change oil plug and check pump oil level before starting. Use Universal Tractor Transmission Oil (UTTO) or Mobil1 Synthetic15w50 for Comet pumps and Cat pump oil (item# 22158) for Cat oil changes.
Water	Make sure your water flow is 20% higher than the pressure washer's flow rate. Make sure your water is clean and particle free.
Storage	Do not allow water to freeze in the pump, hose, coil, or spray gun.
Spraying Chemicals	Use any North Star brand or equivalent pressure washer chemicals.
Maintenance Schedule	Pump Oil: change after first 50 hours, then every 3 months or 500 hours.

Read and understand all manuals before operating.

Any Questions, Comments, Problems or Parts Orders

<p>In the United States Northstar Customer Service Call 1-800-270-0810 Hours: Monday - Friday 7:00 AM to 5:30 PM Saturday 7:30 AM-11:30 AM Central Time</p>	<p>In the United Kingdom Call 02392639752 Northern Tool and Equipment Co. (UK) Ltd. Unit 2, Keel Close, Portsmouth, Hants PO3 5QD, England</p>
---	---

Table of Contents			
Important Safety Instructions	2	Safety Features	13
Grounding Instructions	3	Maintenance Instructions	13-16
Extension Cords	3	Moving and Handling Instructions	17
Specifications	4	Long Term Storage	17
Machine Component Identification	5	Troubleshooting	18
Installation Instructions	6-9	Parts Breakdowns	19-21
Operation Instructions	10-12	Wiring Diagram	22-24

Important Safety Instructions

WARNING -Risk of Injection or Injury to Persons - Do Not Direct Discharge Stream at Persons - Do not use a hose if exterior damage is evident.

CAUTION -Risk of explosion - Do not spray flammable liquids - Do not operate in a flammable environment.
 -Risk of Asphyxiation - Exhaust fumes are deadly. For outdoor use only. Avoid inhaling exhaust fumes.
 -Risk of fire. Do not add fuel when the product is operating or hot.
 -Gun kicks back. Hold with both hands.
 -To reduce the risk of injury, read operating instructions carefully before use.

WARNING - When using this product basic precautions should always be followed, including the following:

- 1.) Read all the instructions before using the product.
- 2.) To reduce the risk of injury, close supervision is necessary when the product is used near children. Do not allow irresponsible use by children. Always stop the product and bleed pressures before leaving unattended, disconnecting hoses, or servicing the pump.
- 3.) Know how to stop the product and bleed pressures quickly. Be thoroughly familiar with the controls.
- 4.) Stay alert - watch what you are doing.
- 5.) Do not operate the product when fatigued or under the influence of alcohol or drugs. Never smoke while operating or fueling this machine.
- 6.) Keep operating area clear of all persons.
- 7.) Do not overreach or stand on unstable support. Keep good footing and balance at all times. Wear footwear capable of maintaining a good grip on wet surfaces - Do not place the machine on soft or unstable ground.
- 8.) Follow the maintenance instructions specified in all manuals. Do not run machine without sufficient lubrication or sufficient water to cool the pump.
- 9.) Wear safety glasses, gloves, face protection and appropriate clothing when operating the machine.
- 10.) Do not operate this machine with broken or missing parts - Never alter the manufacturer's original design or deactivate any safety device on the machine.
- 11.) Risk of exposure to dangerous chemicals. Wear protective gloves when handling and cleaning with chemicals. Follow the chemical manufacturer's directions. Understand all safety hazards and first aid for all chemicals being used. Check whether dangerous chemicals have been used and take any precautions that may have been recommended by the supplier of these chemicals when cleaning filters. Do not pump highly abrasive fluids or use with incompatible chemicals or solvents.
- 12.) Know the pressure and temperature limits of your machine. Be sure all high pressure accessories meet or exceed your machine's limits. Do not set the pressure relief valve above the machine's limit.
- 13.) Do not move this machine by pulling on the hose. Do not use the pump to support other items of equipment that impose unacceptable loads on the pump. Do not attempt to use this machine as a prop.
- 14.) To reduce risk of injury, do not secure the spray gun open. Your spray gun is equipped with a built-in trigger safety latch to guard against accidental trigger release and potentially dangerous high pressure spray. Rotate the safety latch to the locked position when not spraying.
- 15.) Do not clean this machine with its own spray. Cleaning should be done with a damp sponge with the motor OFF.
- 16.) NEVER attempt to immediately run or re-light the burner if it doesn't ignite the first time. Unburned oil or gas may have accumulated causing potential explosion or fire hazard.
- 17.) Always make sure all switches and controls are in the OFF position prior to plugging in the electrical cord. Do not stand in water while plugging and unplugging electrical cord.
- 18.) This product is provided with a ground fault circuit interrupter built into the power cord plug. If replacement of the plug or cord is needed, use only identical replacement parts.

Grounding Instructions

This product must be grounded. If it should malfunction or breakdown, grounding provides a path of least resistance for electric current to reduce the risk of electrical shock. This product is equipped with a cord having an equipment-grounding conductor and a grounding plug. The plug must be plugged into an appropriate outlet that is properly installed and grounded in accordance with all local codes and ordinances.

DANGER - Improper connection of the equipment - grounding conductor can result in a risk of electrocution. Check with a qualified electrician or service personnel if you are in doubt as to whether the outlet is properly grounded. Do not modify the plug provided with the product. If it will not fit the outlet, have a proper outlet installed by a qualified electrician. Do not use any type adapter with this product.

1. For a product rated 125 volts or less:

GROUND FAULT CIRCUIT INTERRUPTER PROTECTION

This pressure washer is provided with a ground fault circuit interrupter (GFCI) built into the plug of the power supply cord. This device provides additional protection from the risk of electric shock. Should replacement of the plug or cord become necessary, use only identical replacement parts that include GFCI protection.

2. For a product rated more than 125 volts:

GROUND FAULT CIRCUIT INTERRUPTER PROTECTION

To comply with the National Electric Code (NFPA 70) and to provide additional protection from the risk of electric shock, this pressure washer should only be connected to a receptacle that is protected by a ground fault circuit interrupter (GFCI).

Extension Cords

Use only 3-wire extension cords that have 3 prong grounding-type plugs and 3-pole cord connectors that accept the plug from the product. Use only extension cords that are intended for outdoor use. These extension cords are identified by a marking "Acceptable for use with outdoor appliances; store indoors while not in use." Use only extension cords having an electrical rating not less than the rating of the product. Do not abuse extension cord and do not yank on any cord to disconnect. Keep cord away from heat and sharp edges. Always disconnect the extension cord from the receptacle before disconnecting the product from the extension cord.

Warning - To reduce the risk of electrocution, keep all connections dry and off the ground. Do not touch plug with wet hands.

SAVE THESE INSTRUCTIONS

Specifications

	Item Number			
	157305	157306	157307	157308
Pressure Rating	1700 psi	2700 psi	2000 psi	2750 psi
Flow Output	1.5 gpm	2.5 gpm	1.5 gpm	2.5 gpm
Pump Type	Ceramic Triplex Plunger	Ceramic Triplex Plunger	Ceramic Triplex Plunger	Ceramic Triplex Plunger
Water Supply	Standard tap water @ 20-100psi	Standard tap water @ 20-100psi	Standard tap water @ 20-100psi	Standard tap water @ 20-100psi
Motor Horsepower	1.5 hp	5 hp	2.0 hp	5 hp
Maximum Temperature	250°F	250°F	250°F	250°F
Approved Fuels	#1 or 2 Diesel, Kerosene, Fuel Oil	#1 or 2 Diesel, Kerosene, Fuel Oil	#1 or 2 Diesel, Kerosene, Fuel Oil	#1 or 2 Diesel, Kerosene, Fuel Oil
Fuel Capacity	8.25 gal.	8.25 gal.	8.25 gal.	8.25 gal.
Discharge Hose	3/8" x 50'	3/8" x 50'	3/8" x 50'	3/8" x 50'
Power Requirements				
Dedicated NEMA Receptacles	5-20R	6-30R	5-20R	6-30R
Volts	115V	230V	115V	230V
Amps	20A	30A	20A	30A
Hertz	60Hz	60Hz	60Hz	60Hz
Phase	single	single	single	single
Dimensions				
Length	38"	38"	38"	38"
Width	26"	26"	26"	26"
Height	43"	43"	43"	43"
Ship Weight	385 lb.	415 lb.	385 lb.	415 lb.

Machine Component Identification

157305, 157306, 157307, 157308

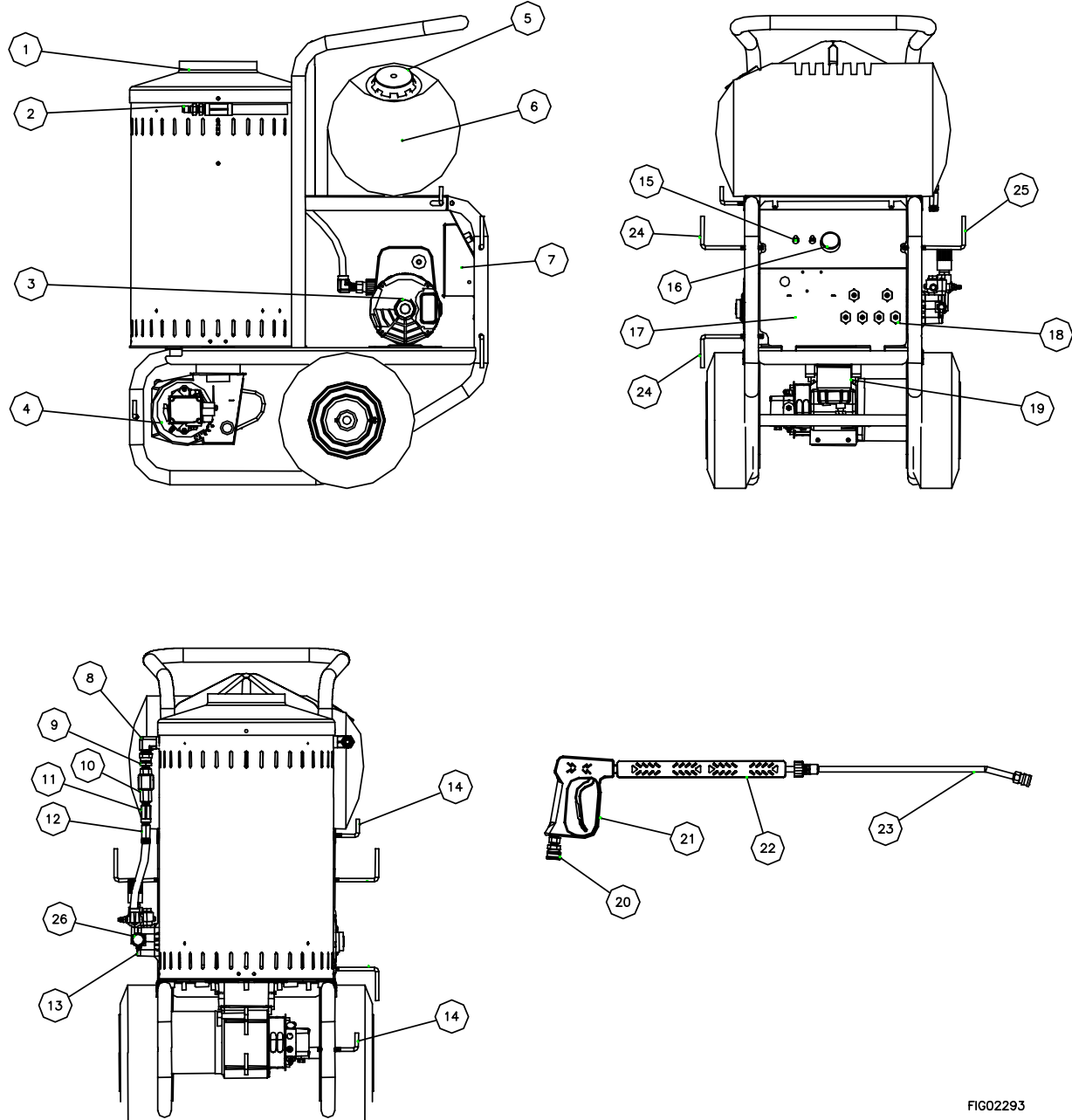

FIG02293

Ref #	Description	Ref #	Description	Ref #	Description
1	Exhaust Vent	10	Flow Switch	19	Fuel Filter
2	High Pressure Water Outlet	11	Tee	20	Quick Connector
3	Motor	12	Safety Relief Valve	21	Spray Gun
4	Burner	13	Pump	22	Grip
5	Fuel Fill Cap	14	Gun Hooks	23	Lance Wand
6	Fuel Tank	15	Power Switch	24	Power Cord Hangers
7	Control Box	16	Thermostat	25	High Pressure Hose Hanger
8	Elbow	17	Service Panel	26	Garden Hose Water Inlet
9	Swivel Fitting	18	Nozzles		

Installation Instructions

I.) Unpack

Separate and identify all components. Use the assembly instructions in this manual for assembly.

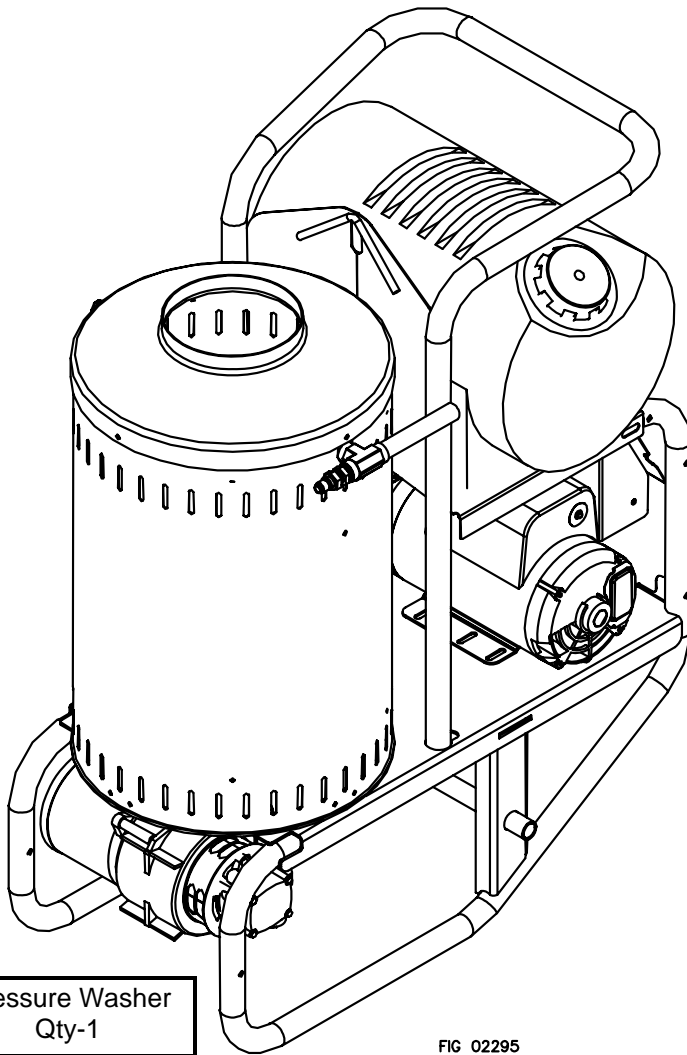
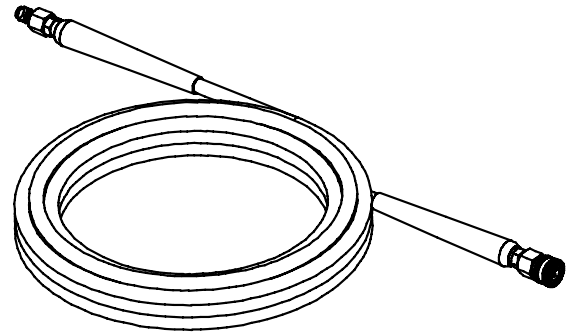
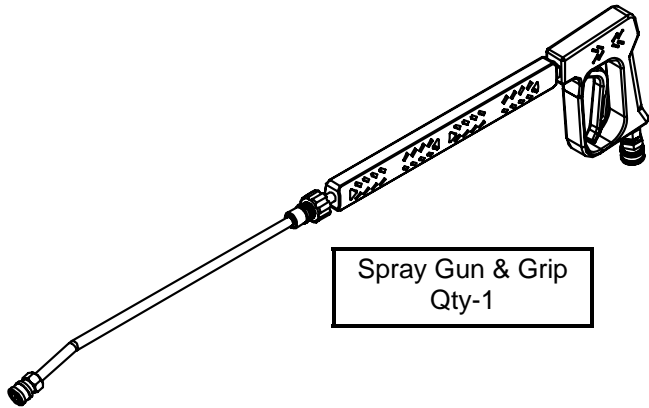
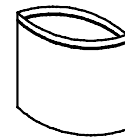

FIG 02295



Fastener Bag
Qty-1



Wheel Retainer
Qty-2

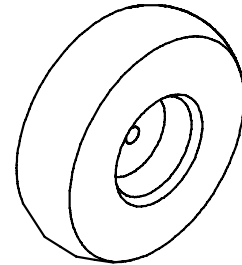

Wheel
Qty-2



Nozzle
Qty-6

II.) Assembly Instructions

- A. 1. Carefully raise the pressure washer off the floor by using blocks or ramps. Make sure the pressure washer is secure before proceeding.
 2. Install the two wheels as shown with grease zerk away from frame.
 3. Slide the two wheel retainers onto the end of the axle. Tighten the set-screw with a hex wrench.

Description	Qty.
Wheel	2
Wheel Retainer	2

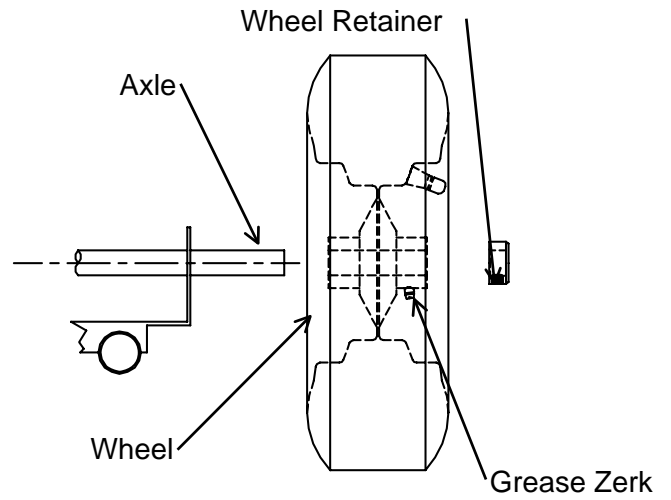

- B. 1. Install the pressure hose onto the pressure washer as shown.
 2. Connect the other end of the pressure hose to the spray gun as shown.
 3. Make sure all plumbing connections are tight.

Description	Qty.
Spray Gun/ Lance	1
Spray Hose	1

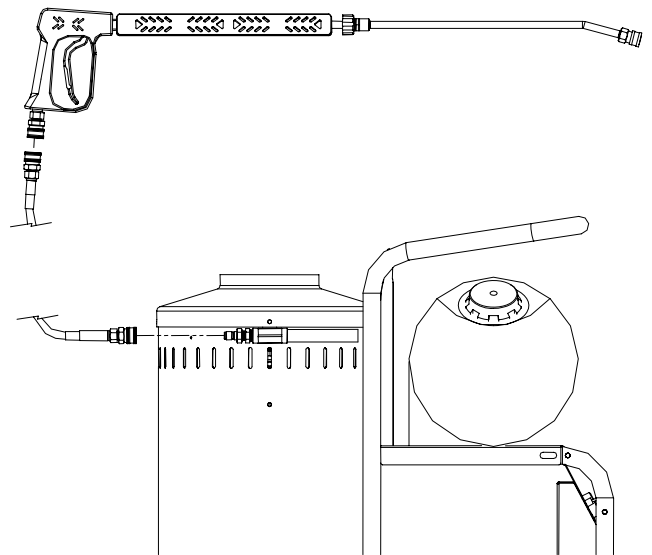
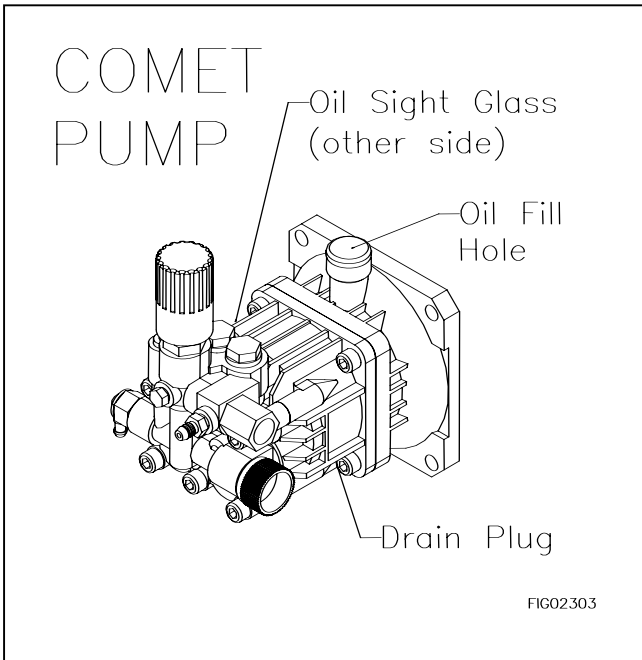

FIG 02296

III.) Pump Preparation

*Comet Pumps Only

- A.) Replace shipping oil plug with vented plug.
- B.) Make sure the oil is 1/2 way up oil sight glass.



Quantities Of Fluid

Pump	Type of Fluid	QTY
Comet BXD 1617	UTTO*	4.3oz (0.13L)
Comet BXD 2527G-E	UTTO*	4.3oz (0.13L)
Cat 2DX	SAE 30**	8.5oz (0.25L)
Cat 3DX	SAE 30**	8.5oz (0.25L)

*Universal Tractor Transmission Oil or Mobil 1 15W50
 **SAE Non-Detergent (order Cat Pump Oil Item# 22158)

**Cat Pumps Only

- A.) Remove shipping tape from oil fill cap
- B.) Make sure the oil is 1/2 way up oil sight glass.

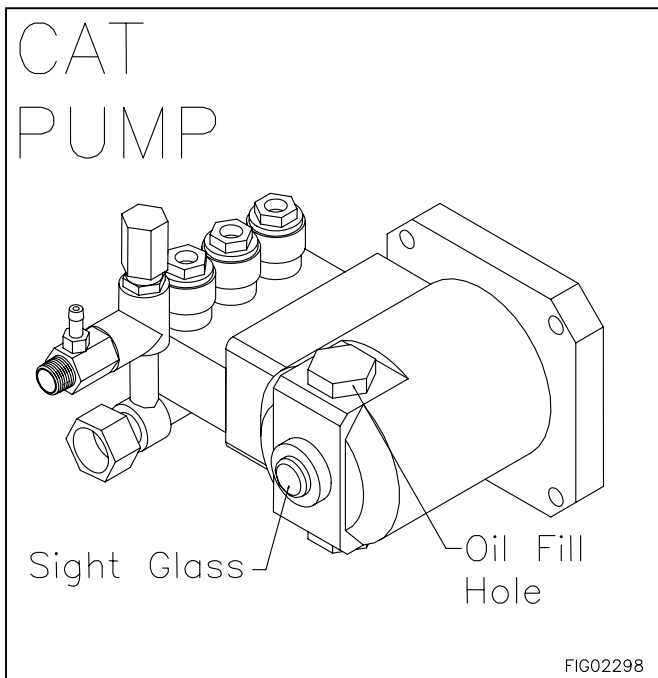

V.) Getting Started

IMPORTANT: Proper initial installation of equipment will assure more satisfactory performance, longer service life and lower maintenance cost.

Make sure the pressure washer is on a level surface and in a protected area where it is not readily influenced by outside forces such as strong winds, freezing temperatures, rain, etc. Locate the pressure washer for easy access for filling fluids, adjustments and maintenance.

It is recommended that a partition be made between the wash area and the pressure washer to prevent direct nozzle spray from coming in contact with the pressure washer. Moisture reaching the equipment will reduce the pressure washer's service life.

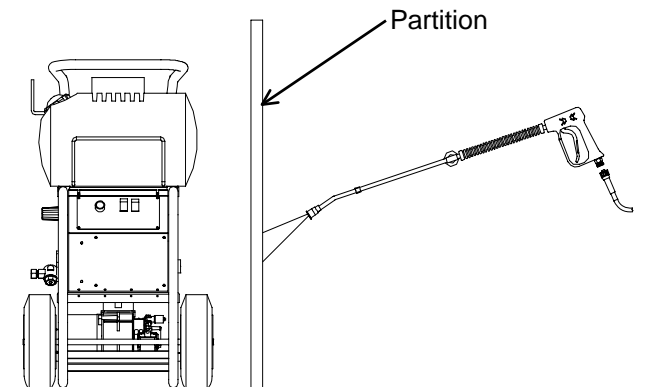

V.) Venting

DANGER: Do not run machine indoors or in an enclosed area without adequate ventilation or in areas where flammable vapors (gasoline, solvents, etc.) may be present. Do not vent exhaust gases into a wall, a ceiling or a concealed space.

CAUTION: All venting must be in accordance with applicable federal and state laws and local ordinances. Consult local heating contractors.

Poor draft will cause the pressure washer to sputter and not operate properly. When selecting the location for installation, beware of poorly ventilated locations or areas where exhaust fans may cause an insufficient supply of oxygen. Proper combustion can only be obtained when there is a sufficient supply of oxygen available for the amount of fuel being burned. If it is necessary to install a unit in a poorly ventilated area, outside fresh air may have to be piped to the burner and a fan installed to bring sufficient air into the unit.

VI.) Oil Burner

Burner Air Adjustment: The oil burner is preset and performance tested at the factory (elevation 1100 feet). A one-time initial correction of the burner for your location will pay off in economy, performance and extended service life.

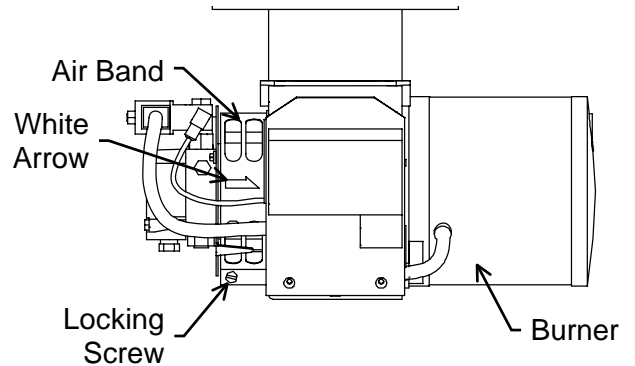

- 1.) Turn the pump and heat switches on (Refer to "Operation" for details). Have someone operate the spray gun so the burner fires.
- 2.) Loosen the locking screw and close the air band until black smoke appears from the burner exhaust vent. Note the position of the white arrow on the air band.
- 3.) Slowly open the air band until white smoke just starts to appear.
- 4.) Turn the air band half way back to the black smoke position previously noted. Tighten the locking screw.
- 5.) Fine tune the burner air by loosening the shutter lock screw and turning the shutter until the exhaust is

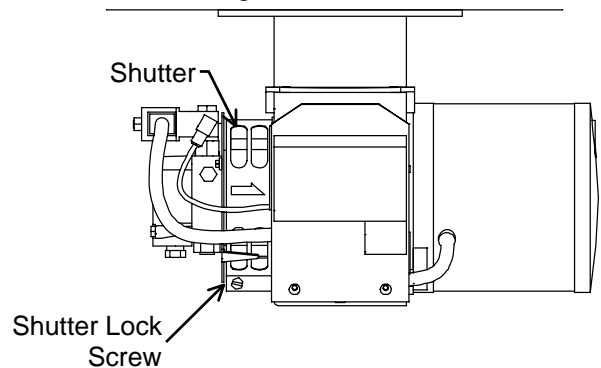

cleanest. Tighten the shutter lock screw.

CAUTION: If white smoke appears from the burner exhaust vent during start-up or operation, discontinue use and readjust air bands.

Operating Instructions

Follow these instructions every time you use the pressure washer.

I.) Pre-Operation

- ☑ A.) Position the machine for easy access to all controls.
- ☑ B.) Position the machine on a solid surface, with less than a three degree slope and so it is protected from external damage.
- ☑ C.) Position the machine so that ambient lighting is sufficient for the surface you are cleaning to be seen with ease. Use artificial light if needed.
- ☑ D.) Check hoses, fittings, wand, trigger gun and fuel connections for signs of wear, cracks and looseness and replace as required.
- ☑ E.) Check and clean the nozzle orifice.
- ☑ F.) Check and clean the water inlet screen and filter.
- ☑ G.) Read entire manual, especially the important safety instructions listed on page 2.
- ☑ H.) Check and maintain proper oil level in the pump.

II.) Check Your Water Supply

- ☑ A.) Make sure the water supply is clean. Debris can cause excess pump wear and reduce performance.
- ☑ B.) An insufficient water supply will damage your pump. Make sure the water supply is steady and is 20% over the rated flow of your pump. Use a stopwatch to time how long it takes to fill a 5 gallon bucket with your garden hose.

Example: If the rated flow is = 3 gpm
Then required flow = $3 \times 1.20 = 3.6$ gpm
 $5 \text{ gallons} / 3.6 \text{ gpm} = 1.39$ minutes
 $1.39 \text{ min} \times 60 \text{ sec/min} = 83$ seconds
Therefore, you must be able to fill a 5 gallon bucket in 83 seconds or faster.

- ☑ C.) The water supply garden hose must have an inside diameter of at least 5/8". If the hose is more than 100 ft. long, the diameter must be at least 3/4".
- ☑ D.) Never use a reservoir tank as a water source. This pressure washer is designed for a pressurized water source such as a city water faucet. Sucking water out of a tank may cause pump cavitation and damage to your pump. However, the inlet pressure of the pump must not exceed 115 psi (8 bar).
- ☑ E.) Always use a flexible rubber hose for your water supply. Do not use rigid piping.
- ☑ F.) Do not pump flammable liquids or liquids containing incompatible chemicals or solvents.

III.) Before Starting

WARNING: Make sure all switches and controls are in the OFF position prior to plugging in the cord. DO NOT stand in water while plugging or unplugging electrical cord.

WARNING: Use a UL recognized receptacle protected by a ground fault interrupter and extension cord of proper voltage and amperage at all times.

1. Connect electrical cord to specified NEMA receptacle. See page 4.

WARNING: Check hoses, fittings, wand, trigger gun and fuel connections daily for signs of wear, cracks and looseness. Replace as required.

2. Connect water supply hose to the garden hose connector located on the pump.
3. Fill the burner fuel tank. We recommend kerosene because it burns cleanest. #1 grade home heating oil, #1 or #2 diesel can also be used. **DO NOT USE GASOLINE OR CRANKCASE OIL.**
4. If detergents will be used, only use detergents intended for pressure washers. Follow instructions on the detergent container.

IV.) To Start

DANGER: Do not point the spray wand at yourself or at any person. Bodily injury may result from water under high pressure.

WARNING: Wear eye, ear, hand, foot and skin protection at all times while operating this pressure washer.

IMPORTANT: The water must be turned on before starting. Running the pump dry will cause damage and void warranty.

1. Turn water supply ON.
2. Squeeze the trigger to allow air to purge from the system. (This step goes faster with the pressure nozzle removed)

V.) Attach Nozzle

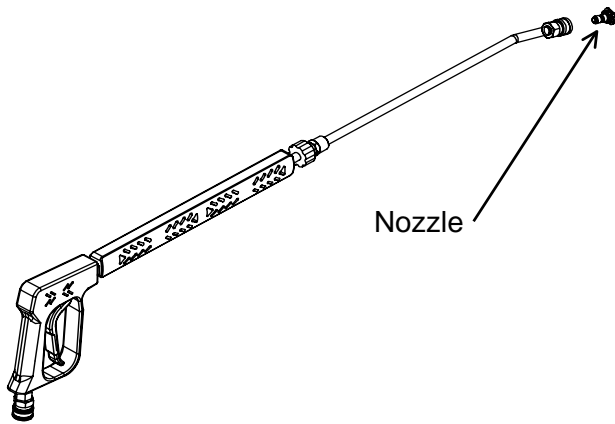

Color of Nozzle:	Spray Angle	Used For:
Red	0	Highest Impact
Yellow	15	Tough Stains/ Stripping
Green	25	General
White	40	Light Cleaning
Yellow	15	Steaming
Black	65	Chemical

Your pressure washer is equipped with six nozzles. To install a nozzle simply pull back the collar towards the lance and push the nozzle into the coupler. Once the connection is made, pull on the nozzle to assure a tight connection.

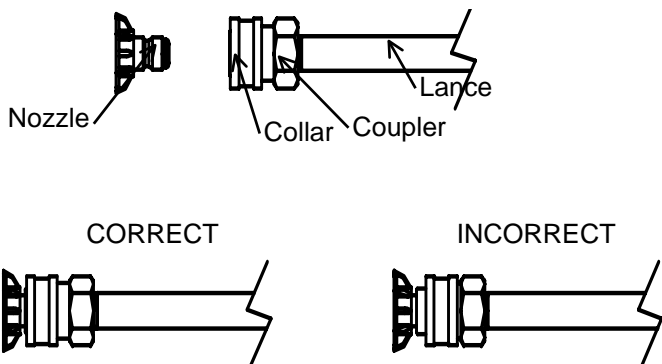

WARNING: Make sure the nozzle is correctly inserted. The nozzle may become a projectile if not inserted correctly. Do not attempt to use different types of nozzles that may not fit the coupler.

VI.) Turn the pump switch ON.

1. Make sure the hose is not kinked. A kinked hose will provide insufficient water supply to the pump and will reduce its life. Make sure the hose remains unkinked after moving the pressure washer.

VII.) For Hot Water

1. If HOT water is desired, make sure there is fuel in the fuel tank, turn the heat switch ON and adjust the thermostat to the desired temperature. The burner will fire when the trigger is squeezed. You may need to initially adjust your burner for peak performance. See the "Oil Burner" section under INSTALLATION. When the trigger is released or the [temperature setting](#) is reached, the burner will automatically turn off.

IMPORTANT: Do not run the machine in hot mode without any fuel in the fuel tank. The fuel pump will be damaged if it is run dry.

To Clean

WARNING: Wear eye, ear, hand, foot and skin protection at all times while operating this pressure washer.

DANGER: Do not point the spray wand at yourself or at any person. Bodily injury may result from water under high pressure.

CAUTION: Be careful on painted or delicate surfaces. The pressure may damage the surface if the nozzle is too close.

IMPORTANT: Your spray gun is equipped with a built-in trigger safety latch to guard against accidental trigger actuation and potentially dangerous high pressure spray. Rotate the safety latch to the locked position when not spraying.

NOTE: Your pressure washer is equipped with a low pressure chemical injector. You do not need to use chemicals for every job, however, the proper chemical used for the proper application can speed up cleaning jobs tremendously.

WARNING: Only use North Star pressure washer chemicals or chemicals specifically formulated for pressure washers. Follow the chemical manufacturer's recommendations. Understand all safety precautions and first aid for all chemicals.

1. Press the braided chemical hose over the chemical injector on the pump and submerge the suction strainer connected to the braided chemical hose into the chemical solution.

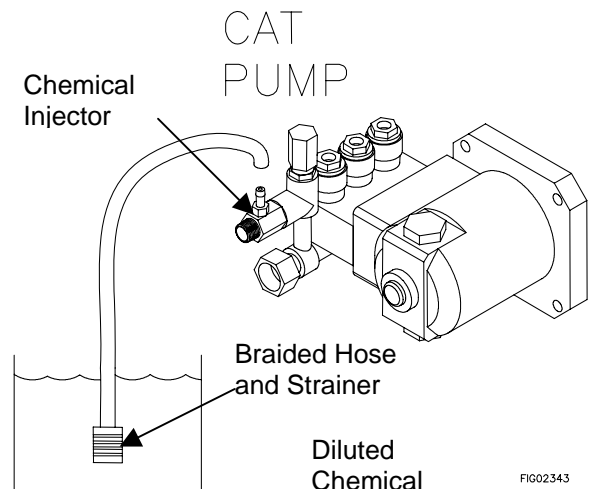

COMET PUMP

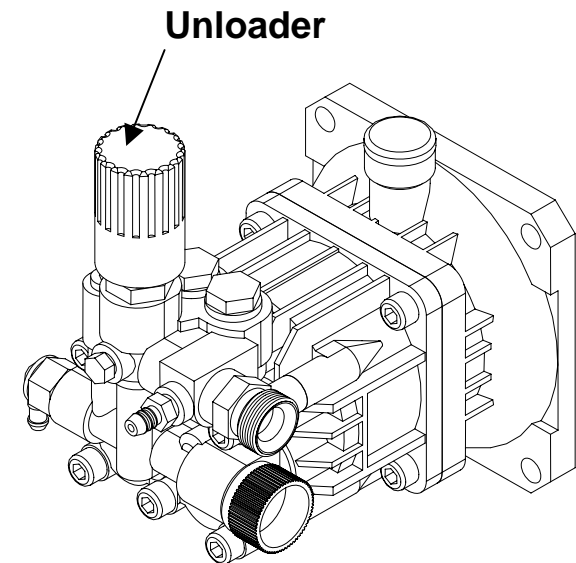
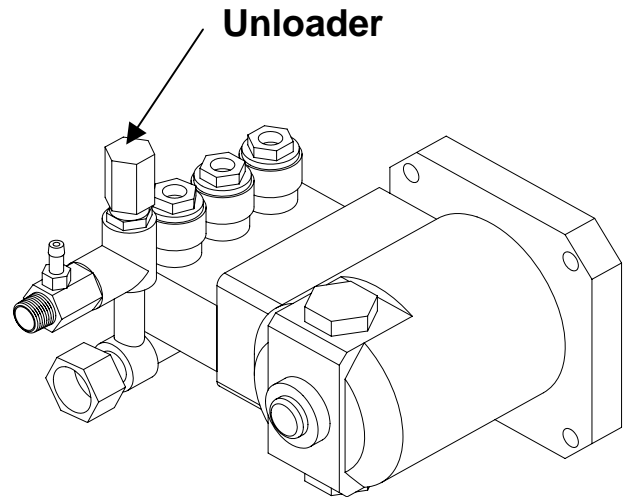
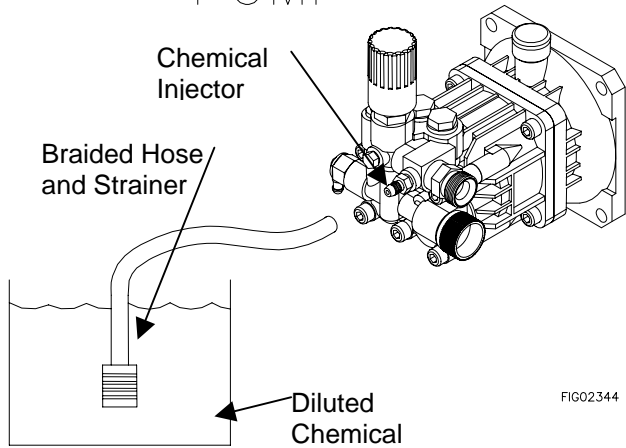

2. The black, low pressure chemical nozzle must be used to spray chemicals.
3. Squeeze the spray gun trigger. The chemical injector will draw the chemical into the water stream.
4. Spray detergent onto the surface and allow it to soak. Chemicals need time to work properly. Follow the chemical manufacturer's recommendations for the recommended time.
5. Change back to high pressure to rinse by inserting one of the high pressure nozzles.
6. Hold the lance with two hands in a sturdy stance position.
7. Point lance at dirty surface and squeeze trigger.
8. Wash from the bottom to the top, using side to side motions. This washes away heavy dirt and allows the detergent to soak as you work toward the top.
9. Use the width of the spray pattern to wash in a wide path. Overlap spray paths for complete coverage.
10. The nozzle should be 12" to 24" from the work, closer for tough areas.

Caution: Be careful on painted or delicate surfaces, the pressure may damage the surface if the nozzle is too close.

11. Small parts should be washed in a basket so the pressure does not push them away. Larger, light weight parts should be clamped down.
12. The pressure washer is set to the maximum rated pressure when it leaves the factory. To adjust the pressure, turn the unloader knob counter-clockwise.

WARNING: Do not alter the unloader valve's maximum pressure. Excess pressures could cause serious injury and/or pump damage. Any alteration other than turning the adjustment knob will void your warranty.

For Steam (Optional)

1. Set the thermostat to 250°F.
2. Turn the Heat switch ON.
3. Insert the steam nozzle into the nozzle holder.

To Stop

1. If detergents were used, draw clear water through the detergent inlet line to purge detergent. Failure to do so may clog the chemical injector.
2. If the burner was used, turn off the "Heat" switch and pump cold water through the coil for 3 minutes. Insufficient cool down period of high pressure hose will cause excessive wear and eventual rupturing of hose.
3. Turn the pump switch OFF.
4. Turn OFF the water supply.
5. Squeeze the trigger to relieve the system pressure.

Safety Features

I.) Safety Relief

The safety relief valve is a backup safety feature. If the unloader malfunctions, the safety relief valve will open

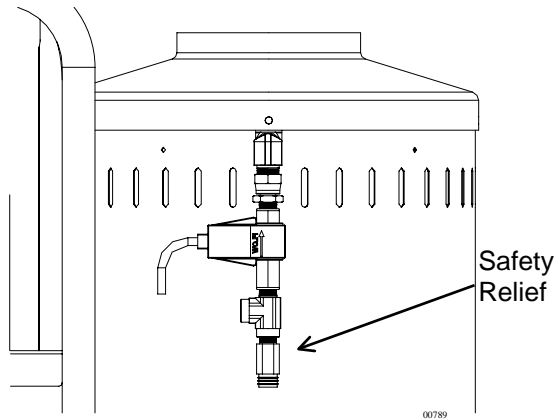

and relieve system pressure.

WARNING: If the safety relief valve ever discharges water, turn the unit off and do not use the machine. See a dealer or call Customer Service at 1-800-270-0810.

II.) High Temperature Limit

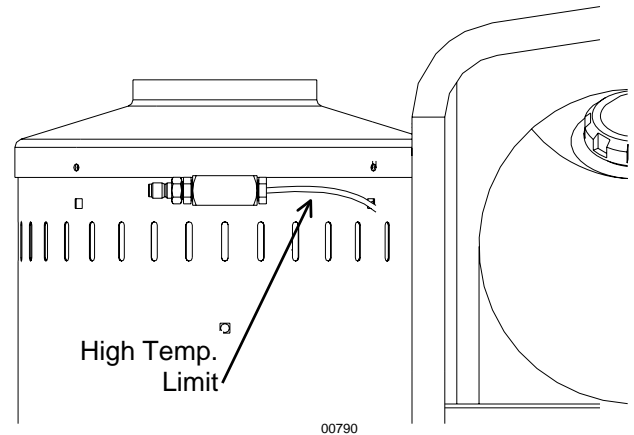

Maintenance Instructions

WARNING: Unauthorized machine modification or use of non-approved replacement parts may cause personal injury and/or property damage and will void the manufacturer warranty.

All mechanical equipment, no matter how well designed, will need repairs. A North Star pressure washer is no exception. At times, a North Star pressure washer may be inoperable because repairs are required. North Star Customer Service will assist in these repairs as needed, but if an inoperable pressure washer creates a major expense to your business then we strongly recommend the following:

1. Have someone on staff who is trained in the operation of the pressure washer and is capable of making minor repairs and performing all preventative maintenance procedures as outlined in the provided manuals.
2. Keep a stock of recommended service parts for maintenance and minor repairs.

Maintenance Mode

Before performing any maintenance on the pressure washer, it must be placed in maintenance mode.

- A.) Turn off water supply
- B.) Bleed water from system
- C.) Turn off and unplug power cord

Maintenance Schedule

What to Check	When To Check	What to Do
Fuel Filter	500 hrs	Change
Inlet Filter	Each Use	Clean
Tires	Each Use	Check Pressure
Hoses	Each Use	Check for Wear
Bolts	Each Use	Check for Loose Bolts

Cleaning The Inlet Filter

WARNING: Check whether dangerous chemicals have been used and take precautions when handling filters.

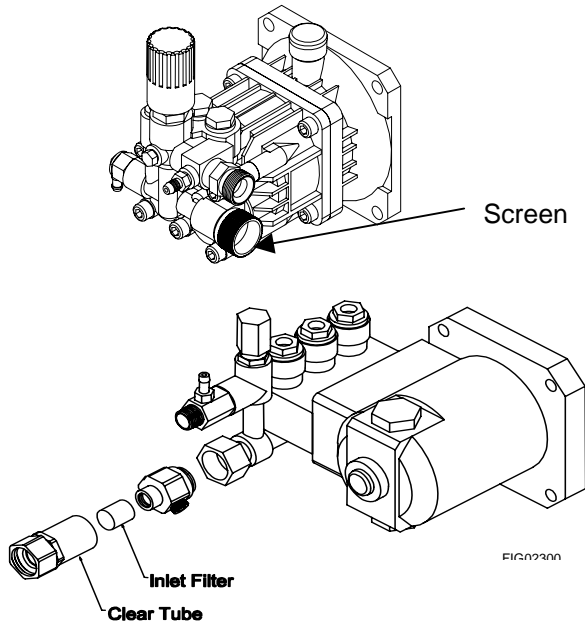

- A.) Unscrew clear tube by hand.
- B.) Remove Inlet filter
- C.) Run water through to clean filter

Checking the Tire Air Pressure

- A.) Remove air fill cap
- B.) Fill tire to 20psi (1.4bar)
- C.) Replace air fill cap

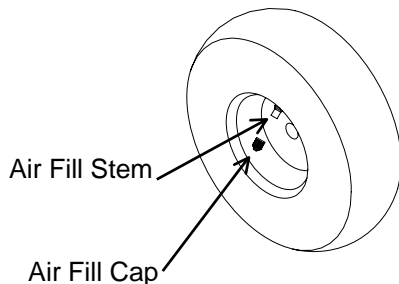

Burner Fuel Filter

Drain water which has accumulated in the fuel filter bowl and replace the filter as needed.

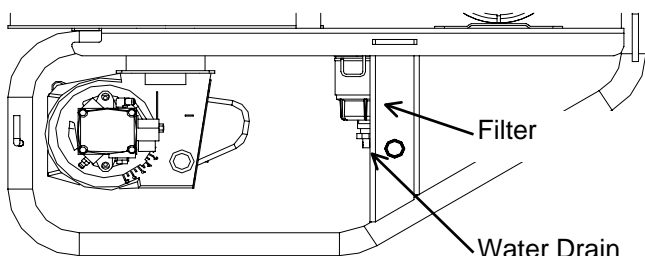

Checking the Hoses

WARNING: Do not use a finger or skin to check for leaks. Escaping fluid under pressure has sufficient force to penetrate the skin, causing serious injury. Do not operate the pressure washer if the hose is cracked, worn or leaking.

- A.) Check all hoses for leaks
- B.) Check all hoses of worn areas

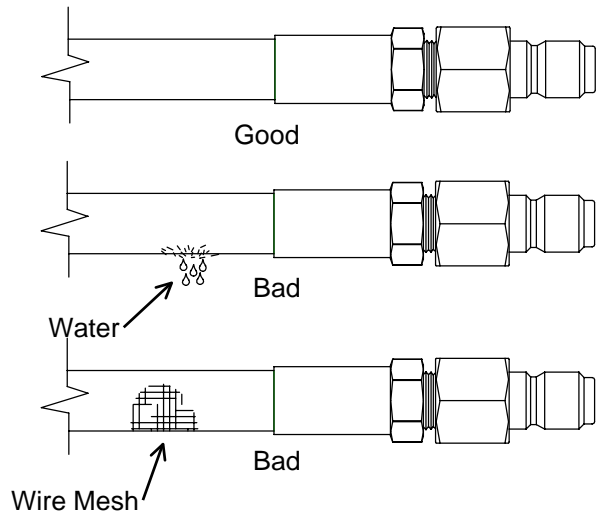

Changing The Pump Oil

*Change oil after first 50 hours, then every 3 months or 500 hours

- 1.) Remove oil drain plug
- 2.) Drain pump oil.
- 3.) Replace oil drain plug.
- 4.) Fill pump oil according to table below.
- 5.) Use sight glass to fill to proper level.

Quantities Of Fluid

Pump	Type of Fluid	QTY
Comet	UTTO*	4.3 oz (0.13L)
CAT	SAE 30**	8.5 oz (0.25L)

*Universal Tractor Transmission Oil of Mobil 1 15W50

**Non-Detergent Oil (order pump oil Item #22158)

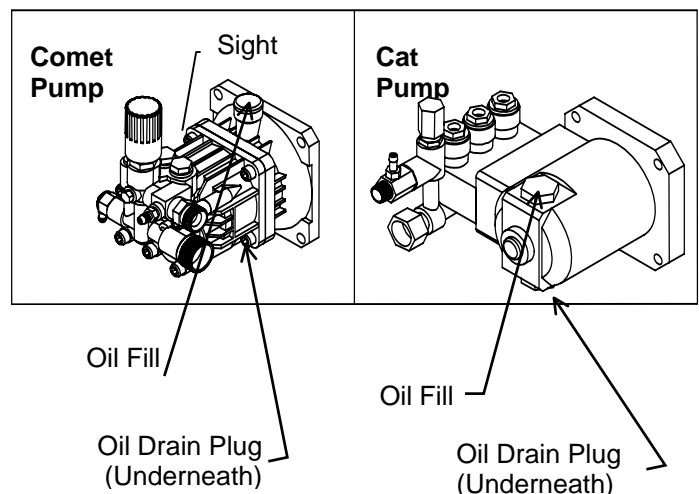

Coil Descaling

In hard water areas, scale build-up within the heating coil will occur. Scale deposits will decrease the water temperature rise and may eventually clog the heating coil.

1. Mix scale remover in a 5 gallon bucket and elevate the bucket so it is higher than the pump.
2. Attach the high pressure hose to the high pressure water outlet on the machine. Do not hook up the spray gun.
3. Place the other end of the high pressure hose in the 5 gallon bucket.
4. Attach a short length of hose to the garden hose inlet on the pump.
5. Prime the pump by filling the hose with water, then place the end of the hose in the bucket.

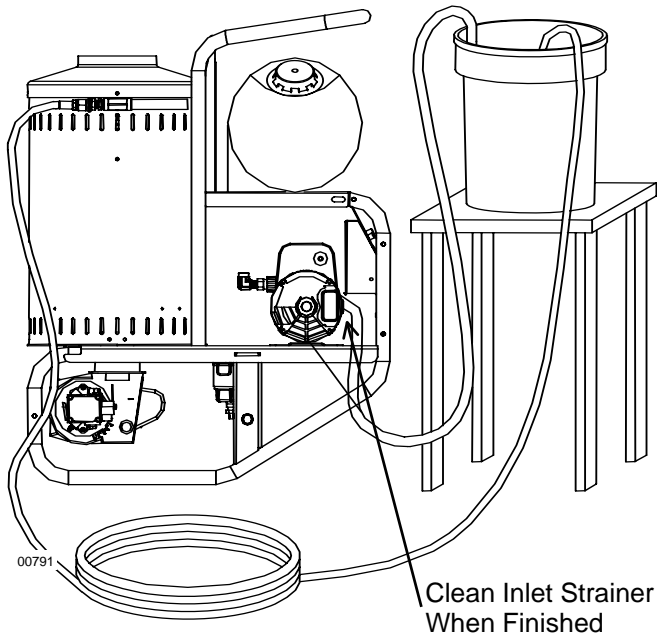

6. Run the pressure washer in cold mode for 1 to 3 hours recirculating the cleaning solution.

Warning: Do not run the burner.

7. Dispose of the cleaning solution where it is not harmful to animals or the environment.
8. Flush with fresh water and clean the inlet strainer when finished.

Coil Desooting

Poor grades of fuel oil or inadequate combustion air will cause heavy soot build-up on the outside surface of the heating coil. These deposits will insulate the coil. This will restrict the air flow through the coil, further aggravating the soot build-up.

Most coils will never require desooting. However, to desoot a coil...

1. Wear protective clothing, goggles, and gloves.
2. Remove the fittings from the inlet and outlet of the coil.
3. Remove the lid from the heating chamber and hoist the coil out. Be careful, the coil is very heavy.

Important: Be careful not to damage the threads on the coil inlet and outlet. If the threads get damaged, it will be hard to reconnect and seal the fittings on the coil inlet and outlet.

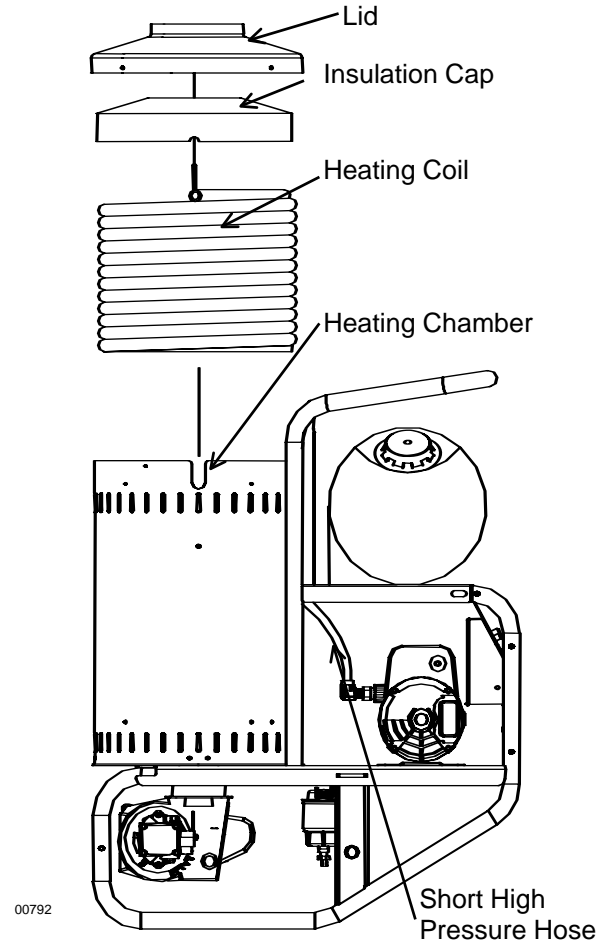

4. Clean the coil.
5. Reassemble the coil to the machine. Make sure the white insulation remains in place.
6. Make sure all fittings are tight before using the machine. Use thread sealant on all threads.

Electrodes

On a yearly basis the electrodes should be inspected and any necessary adjustments made.

1. Tip the machine back until it rests on the frame.
2. Remove the 4 nuts that attach the burner to the

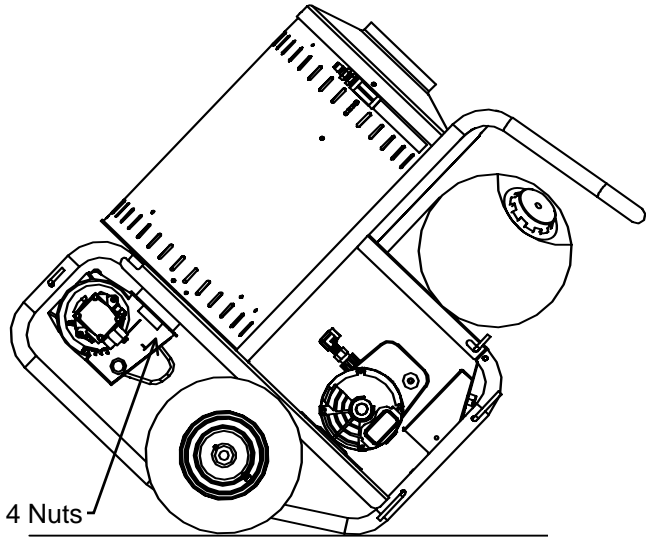

00793

heating chamber. You do not have to disconnect the fuel lines or the electric cords.

3. Let the burner fall away from the heat exchanger.

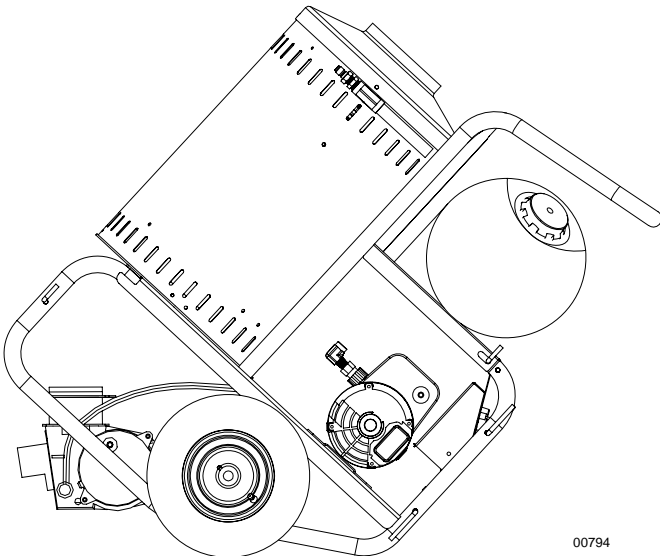

00794

4. Clean off carbon deposits, which may have accumulated on the tips of the electrodes.
5. Reset the spacing as shown below.

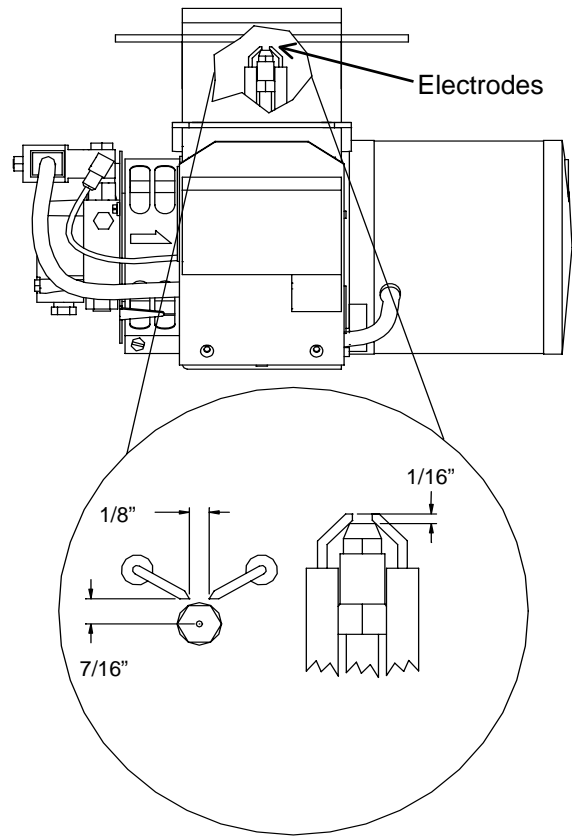

Moving and Handling Instructions

Maneuvering Your Pressure Washer

- 1.) Pull the handle back with both hands.
- 2.) Rotate the handle downward to a comfortable height.
- 3.) Push the pressure washer forward as you walk.

Lifting Your Pressure Washer

- 1.) To reduce risk of injury, it is recommended to use a hoist to lift this pressure washer.
- 2.) Lift from lifting point (see picture)

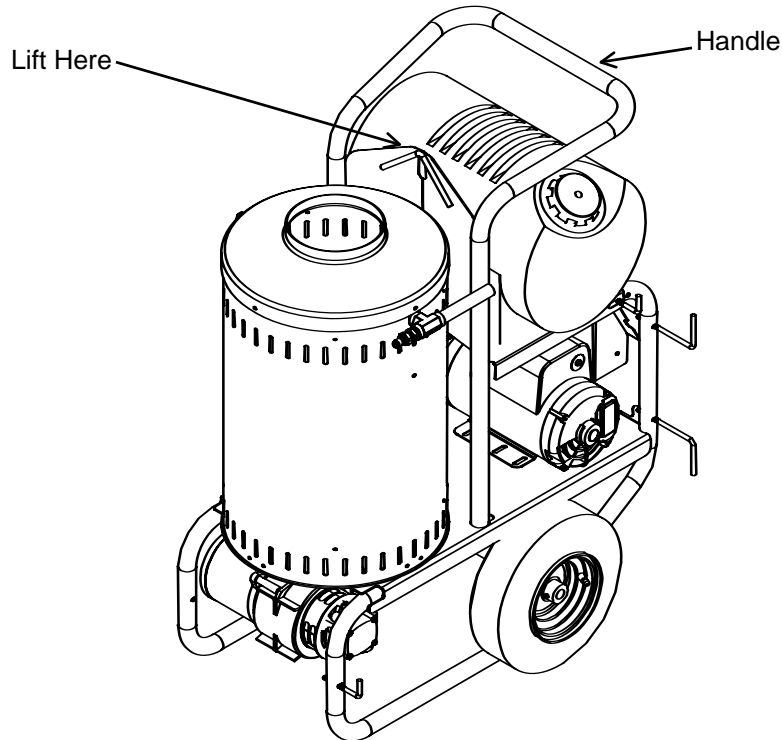

Long Term Storage

During cold weather, store the pressure washer indoors and move it outdoors before starting. Follow these instructions to prevent the pump from freezing during storage.

Winter Storage:

Items needed: 12" piece of garden hose or equivalent, funnel and RV antifreeze (approximately 2 gallons).

- 1.) Attach the garden hose with funnel to the pump inlet (see illustration).
- 2.) Pour RV antifreeze into the funnel.
- 3.) Turn the unit on and make sure the burner is off.
- 4.) Let the pump run no more than 15 seconds at a time until antifreeze comes out the high pressure outlet.
- 5.) It will take about 1.5 gallons of antifreeze to fill the pump and heat exchanger coil.
- 6.) Drain all water from the high pressure hose. Depress trigger on gun and drain all water out of gun/lance.

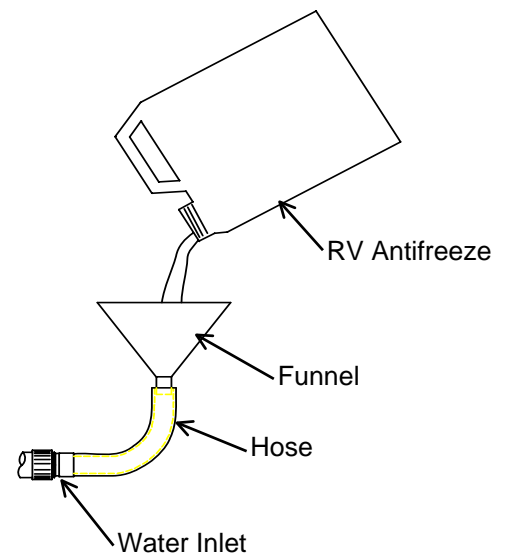

Troubleshooting Guide

Pressure Washer Will Not Run - No Power

Causes	Solutions
Machine not plugged in	Plug machine in
GFCI tripped	Make sure machine is dry Press RESET on the GFCI
Machine turned OFF	Turn Pump switch ON
Line circuit breaker tripped	Check for tripped circuit breaker in building

Circuit Breaker Trips During Operation

Causes	Solutions
Voltage too low	Check the voltage
Circuit Breaker Overloaded	Make sure to use NEMA specified receptacle Make sure there is no other equipment using the same circuit - see <i>Specifications</i>
Pressure set too high	Check/adjust pressure setting on unloader

Pressure Washer Runs But No Pressure

Causes	Solutions
Partially clogged or damaged nozzle	Clean or replace nozzle
Low water flow	Make sure the water supply is more than the required flow

Pressure Washer Surges Or Cycles While In Bypass

Causes	Solutions
Leak between pump and gun	Check all connections between pump and gun for leaks Tighten loose components and replace damaged components
Gun leaking internally	Replace spray gun

Smoke From Heat Exchanger

Causes	Solutions
Air band not adjusted properly due to different elevation	Adjust the air band until the burner burns cleanly See <i>Oil Burner</i> under <i>Installation Instructions</i>
Poor quality fuel	Use Kerosene for the cleanest burn

Water Not Heating Sufficiently

Causes	Solutions
Scale build-up in coil	See <i>Coil Descaling</i> under <i>Maintenance Instructions</i>
Coil is full of soot	See <i>Coil Desooting</i> under <i>Maintenance Instructions</i>

Safety Relief Valve Sprays Water

Causes	Solutions
Unloader/Burner Control Problem	Call customer service

Poor Or No Detergent Supply

Causes	Solutions
Inadequate detergent supply	Refill detergent container Make sure the chemical strainer is fully submerged
High pressure hose too long	Use less hose Move machine closer to the work
Chemical strainer or injector clogged	Clean the strainer and injector. Always start with a clean detergent container. Run clean water through the injector after each use.

M157305H - 157305,157306,157307, 157308
Parts Breakdown

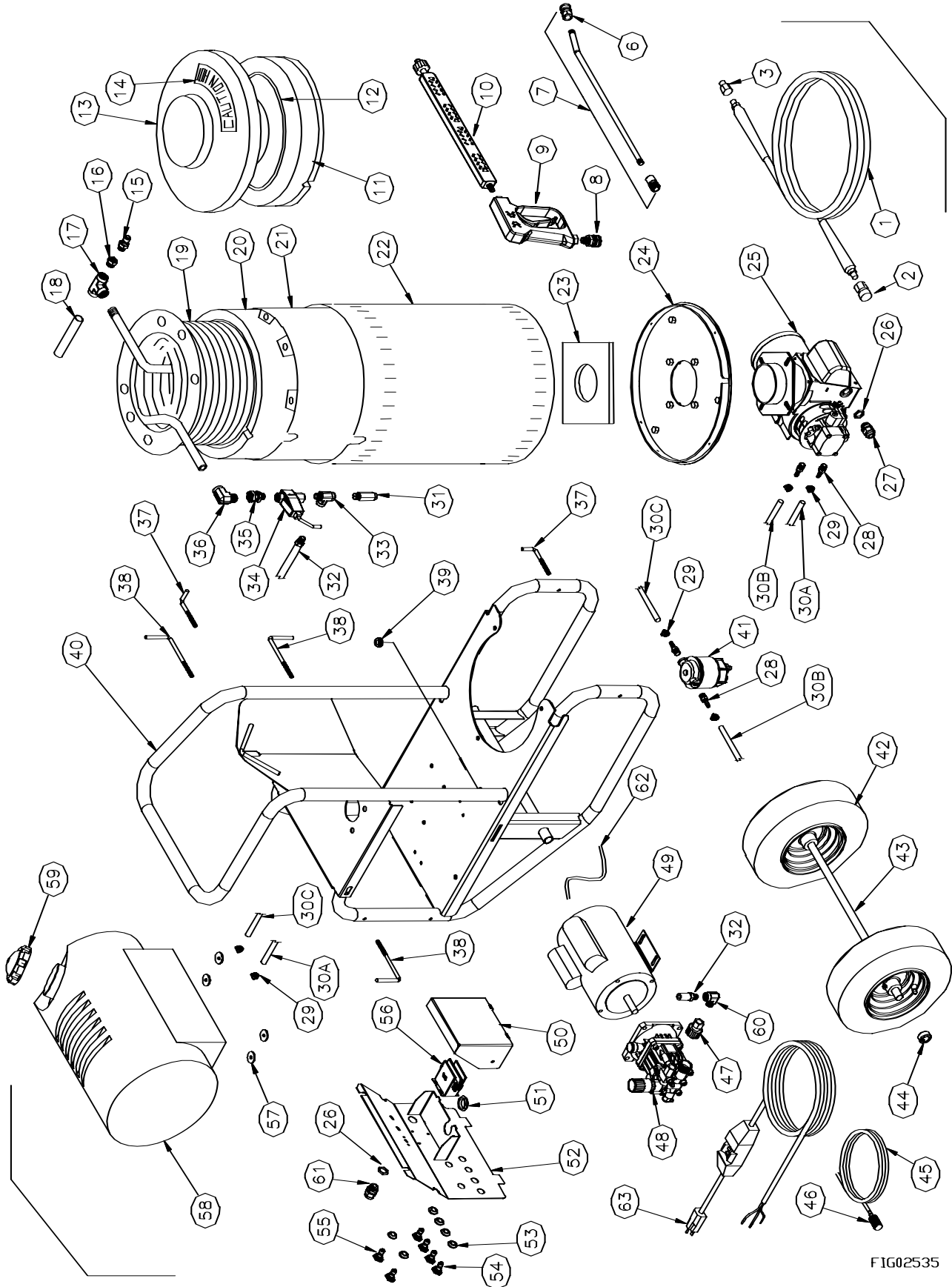

FIG02535

M157305H - 157305,157306,157307, 157308

Parts List

ITEM	PART #	DESCRIPTION	QTY	MODEL
1	38525	50' PW Hose Assy	1	ALL
2	777914	Quick Couple, 3/8" FPT	1	ALL
3	777915	Quick Couple Nipple, 3/8" FPT	1	ALL
6	777904	Quick Coupler, 1/4" FPT	1	ALL
7	779166	Lance Assembly	1	ALL
8	313107	Quick Couple, 3/8" FPT	1	ALL
9	779168	Gun Trigger Assembly	1	ALL
10	22622	Gun Grip	1	ALL
11	38398	Insulation Cap Assembly	1	ALL
12	36302	Fiberglass Rope	49"	ALL
13	35331	Heat Exchanger Lid	1	ALL
14	305410	~Caution Hot~ Decal	1	ALL
15	777913	Quick Couple Nipple, 3/8"	1	ALL
16	30048	Reducer, 8MP - 6FP	1	ALL
17	305208	Tee, 8FP	1	ALL
18	778179	Kink Guard	1	ALL
19	779228	Coil Assembly	1	ALL
20	33387	Insulation Can	1	ALL
21	779232	Fire Chamber	1	ALL
22	37530	Vented Wrap	1	157305, 157306
	36180	Vented Wrap, Stainless	1	157307, 157308
23	38120	Insulation Gasket	1	ALL
24	778111	Heat Exch. Mount Weld.	1	ALL
25	777166	Burner, 120V	1	157305, 157307
	778189	Burner, 230V	1	157306, 157308
26	305267	Strain Relief Nut	2	ALL
27	22502	Strain Relief	1	157306, 157308
28	777340	Hose Barb, 1/4" MPT x 1/4"	4	ALL
29	777834	Hose Clamp, 1/4"	4	ALL
30A	777345	Fuel Line, 1/4" Burner-Tank	25"	ALL
30B	777345	Fuel Line, 1/4" Filter -Burner	10"	ALL
30C	777345	Fuel Line, 1/4" Tank to Filter	25"	ALL
31	35104	Pop Off Valve, 3/8"	1	157305, 157307
	22392	Pop Off Valve, 3/8"	1	157306, 157308
32	778195	3000PSI RXS Hose, 3/8x18"	18"	157305, 157306
	778193	3000PSI RXS Hose, 3/8x26"	26"	157307, 157308
33	777347	Tee, 6MP-6FP-6FP	1	ALL
34	37537	Flow Switch	1	ALL

ITEM	PART #	DESCRIPTION	QTY	MODEL
35	38379	Swivel Fitting, 6MP-8FPS	1	ALL
36	5027	Elbow, 8MP-FP	1	ALL
37	38509	Threaded Gun Hook	2	ALL
38	38510	Threaded Hose Hook	3	ALL
39	777111	Grommet	1	ALL
40	778092	Hot Water Frame	1	ALL
41	32308	Fuel Filter, Water Separator	1	ALL
42	30388	Pneumatic Wheel/Tire	2	ALL
43	305408	Axle	1	ALL
44	305200	Wheel Retainer	2	ALL
45	777165	Braided Chemical Hose, 1/4"	36"	157305, 157306
	777165	Braided Chemical Hose, 1/4"	36"	157307, 157308
46	2212	Chemical Strainer	1	ALL
47	778236	Thread-on Coupler, 22mm	1	157305, 157306
	779402	Comet BXD 1617	1	157305
	779403	Comet BXD 2527G-E	1	157306
48	778154	Cat 2DX	1	157307
	38518	Cat 3DX	1	157308
	777616	Leeson, 1.5 HP Motor	1	157305
49	778670	Leeson 5 HP Motor	1	157306, 157308
	777617	Leeson, 2 HP Motor	1	157307
50	779303	Control Box Cover	1	ALL
51	31985	Grommet	1	ALL
52	779301	Control Panel Weldment	1	ALL
53	35198	Grommet, 7/16" ID	6	ALL
54	778197	Nozzle 5-pack, #2.0	1	157305, 157307
	38531	Nozzle 5-pack, #3.0	1	157306, 157308
55	778198	Steam Nozzle, 15 Deg	1	ALL
56	778151	DP Contactor, 120V/25A	1	157305, 157307
	778152	DP Contactor, 230V/30A	1	157306, 157308
57	30754	Leather Washer	4	ALL
58	30540071	Fuel Tank	1	ALL
59	305206	Printed Fuel Cap	1	ALL
60	777410	Elbow, 3/8" NPT	1	157305,157306
61	305266	Strain Relief, 1/2" NPT	1	157306,157308
	778194	Motor Power Cord 14/3	1	157305
62	778191	Motor Power Cord 12/3	1	157306, 157307, 157308
63	778141	GFCI Cord, 120V/20A, 36 ft	1	157305, 157307
	778142	GFCI Cord, 240V/30A, 36 ft	1	157306, 157308

157305 & 157306

157307 & 157308

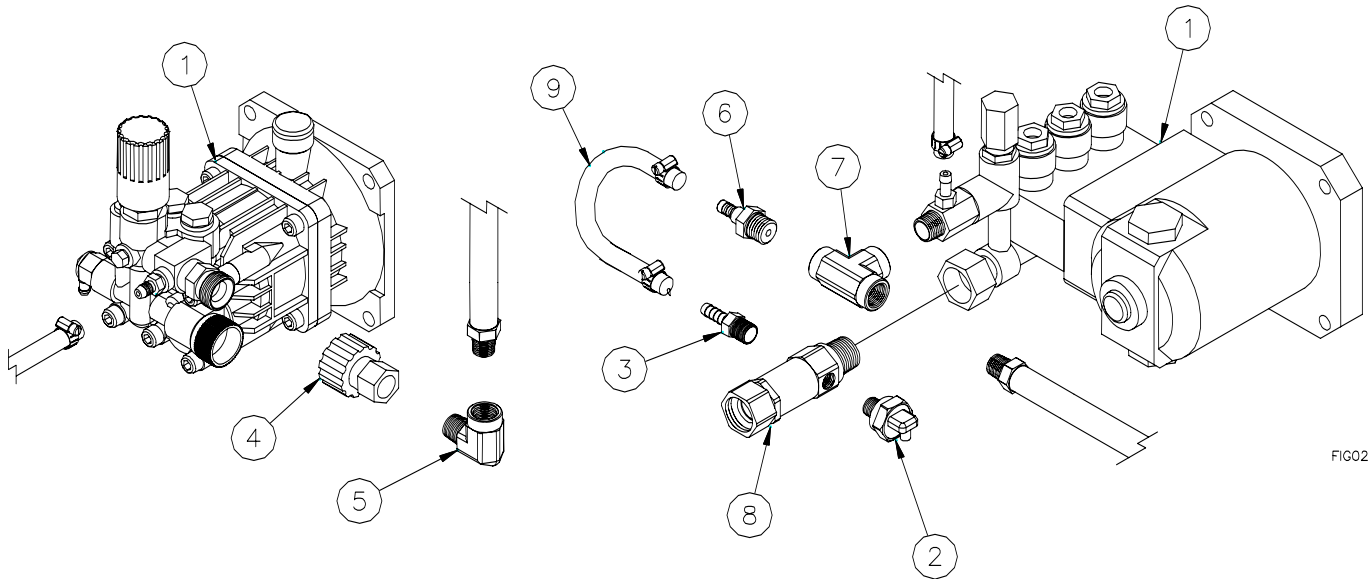

FIG02298

ITEM	PART #	DESCRIPTION	QTY	MODEL
1	779402	Comet BXD 1617	1	157305
	779403	Comet BXD 2527G-E	1	157306
	778154	Cat 2DX	1	157307
	38518	Cat 3DX	1	157308
2	35918	Thermal Protector, 1/4"	1	157307, 157308
3	777340	1/4" MPT x 1/4" Hose Barb	1	157308
4	778236	22mm Thread-On Coupler	1	157305
5	777410	3/8" Street Elbow	1	157305, 157306
6	38584	3/8" NPT Easy Start Valve	1	157308
	777837	3/8 Plug	1	157307
7	777411	3/8" Tee	1	157307, 157308
8	38596	Inlet Filter	1	157307, 157308
9	777165	Braided Chemical Hose, 1/4"	12"	157308

ITEM	NAME	QTY
1	777855	2
2	305422	1

CONTROL BOX WIRING

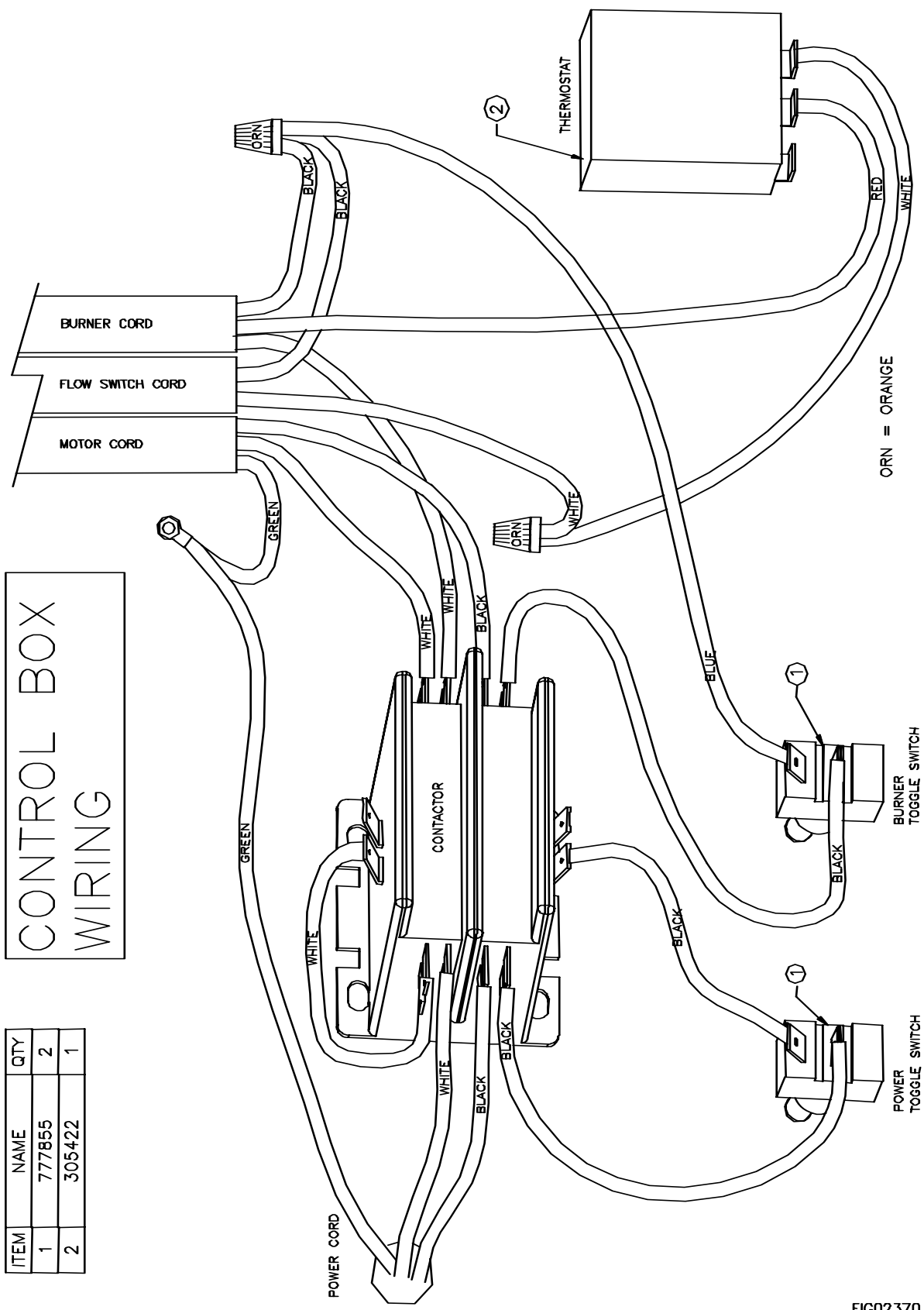
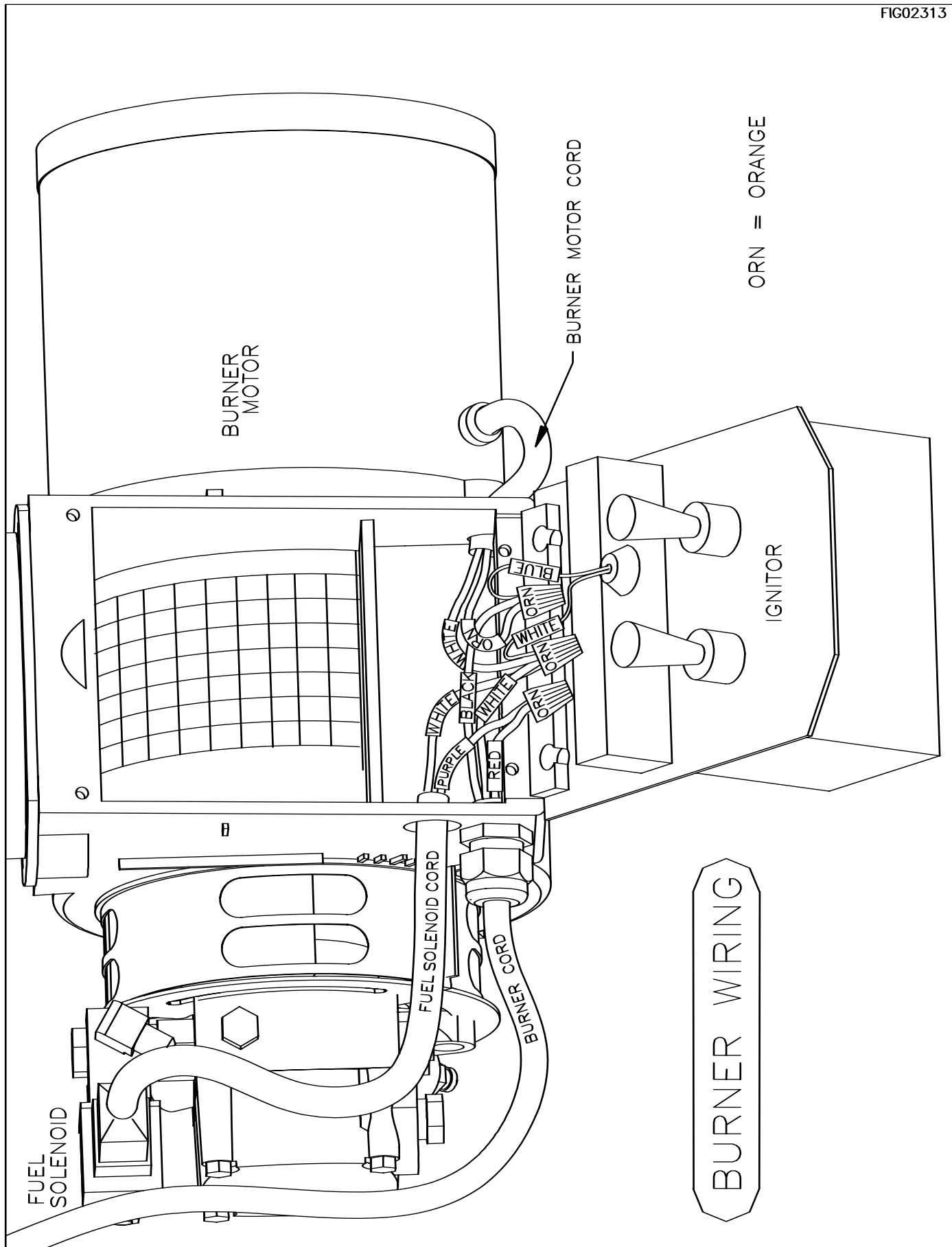
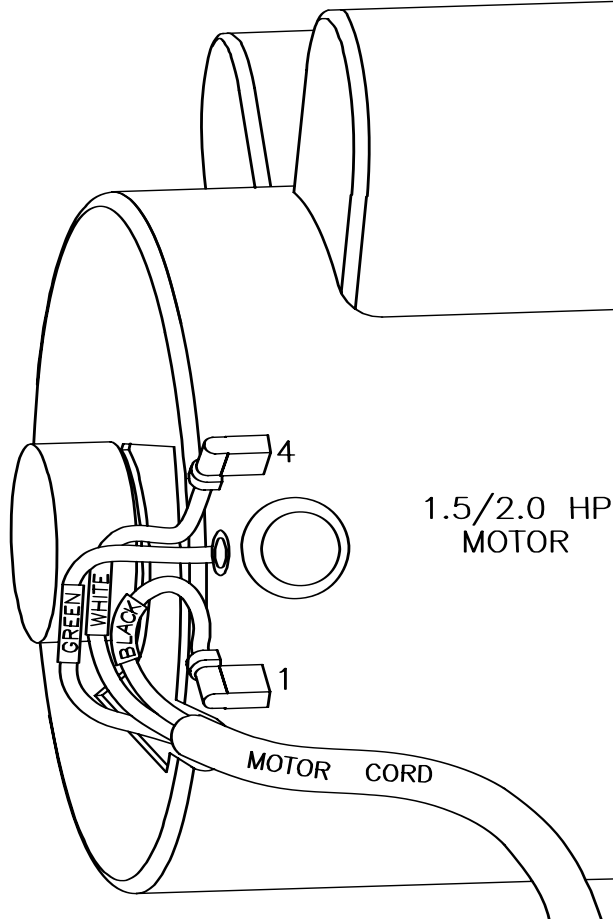

FIG02370



1.5/2.0 HP MOTOR WIRING



5 HP MOTOR WIRING

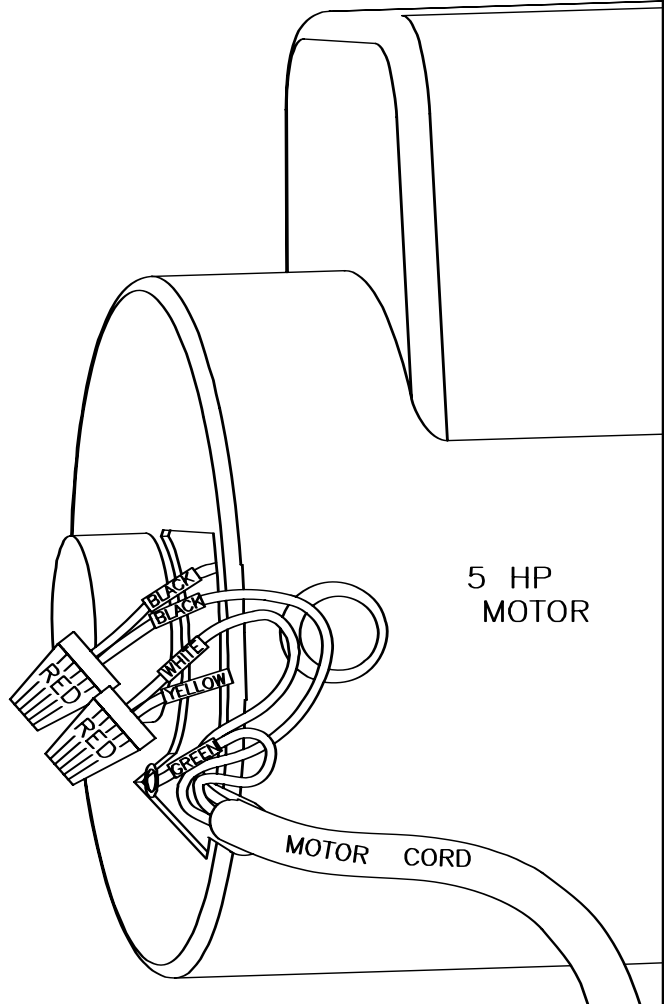

ELECTRICAL SCHEMATIC

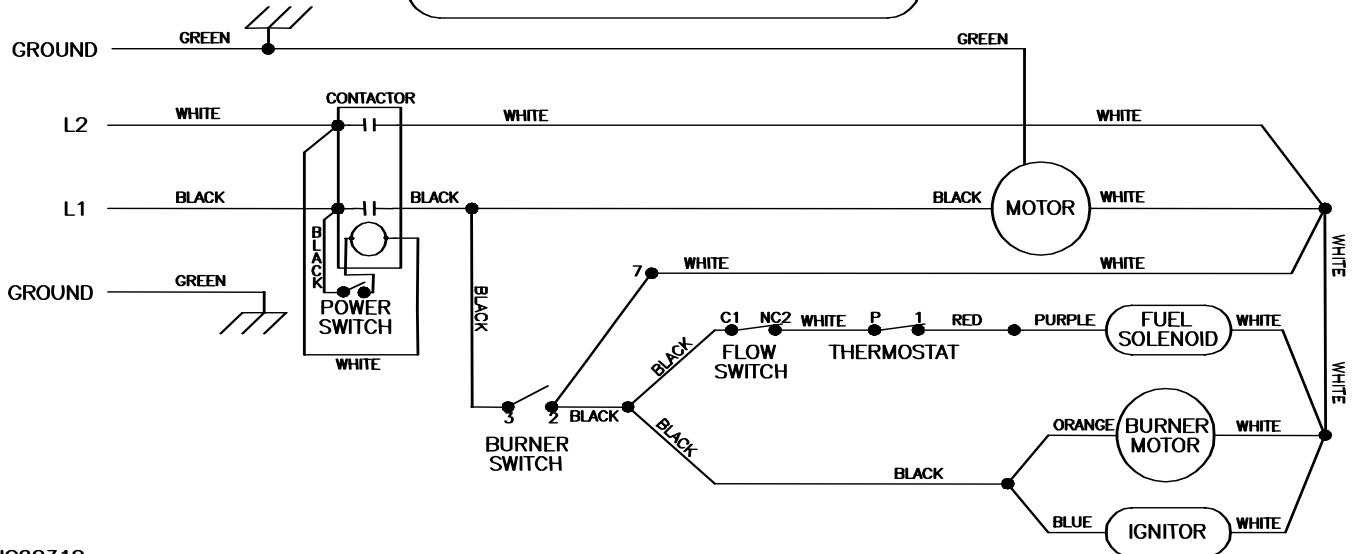

FIG02312