

# Electrolux

## Pasta Solutions Free-standing, Single-well Pasta Cooker – Gas Rapid System

ITEM # \_\_\_\_\_

MODEL # \_\_\_\_\_

PROJECT NAME # \_\_\_\_\_

SIS # \_\_\_\_\_

AIA # \_\_\_\_\_



### Pasta Solutions Free-standing, Single-well Pasta Cooker – Gas Rapid System

200372 (NCPG1RU) Rapid System Gas Pasta Cooker  
208 V/3p/60z – 7.7 A

### Short Form Specification

Item No. \_\_\_\_\_

Unit to be Electrolux Single Well Gas Pasta Cooker 200372. Features incoming water booster heater. The unit is a free-standing, 10.5 gallon, single well Gas Pasta Cooker. The unit shall feature constant water level refill and starch removal during cooking process. IPX 5 water jet protection (NEMA 4 equivalent). The 10.5 gallon tank is pressed in AISI 316 stainless steel and features only rounded corners. 5" long, height adjustable legs. The unit to be completely in AISI 304 stainless steel.

Covered by Electrolux Platinum Star® Service Program two-year parts and one-year labor warranty, installation start-up and performance check-up after one year from installation.

### Main features

- Rapid system: incoming water booster heater.
- 10.5 gallon tank.
- 9-position energy regulator.
- 3-position water fill regulator.
- Constant water level refill.
- Automatic starch removal function during cooking: improved water quality over time.
- Automatic low-water level shut-off: no accidental over-heating.
- Electrolux Platinum Star® Service package included:
  - 2-year parts, 1-year labor warranty, 5-year compressor warranty.
  - Start-up install check.
  - Equipment check-up after 12 month from installation.

### Construction

- Pressed 10.6 gal tank: only rounded corners for improved cleanability.
- AISI 316 stainless steel tank: maximum corrosion resistance.
- All stainless steel construction.
- IPX 5 water jet protection (NEMA 4 equivalent).

### Included Accessories

- 5" long, height adjustable legs.

### Optional Accessories

- Bulk cooking basket.
- 2 of 1/2 size bulk cooking baskets.
- 3 of 1/3 size bulk cooking baskets.
- 3 of round individual-portion baskets.
- False bottom for round individual-portion baskets.
- Castors.



Approval: \_\_\_\_\_

**Electrolux Professional, Inc.**

[www.electroluxusa.com/professional](http://www.electroluxusa.com/professional)

3225 SW 42nd Street, Fort Lauderdale, Florida, 33312 • Telephone Number: 866-449-4200 • Fax Number: 954-327-6789

 **Electrolux**  
Free-standing, Single-well Pasta Cooker – Gas Rapid System  
Pasta Solutions

**Front View**

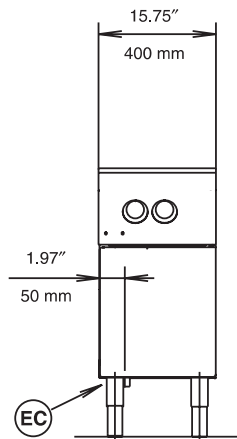

**Top View**

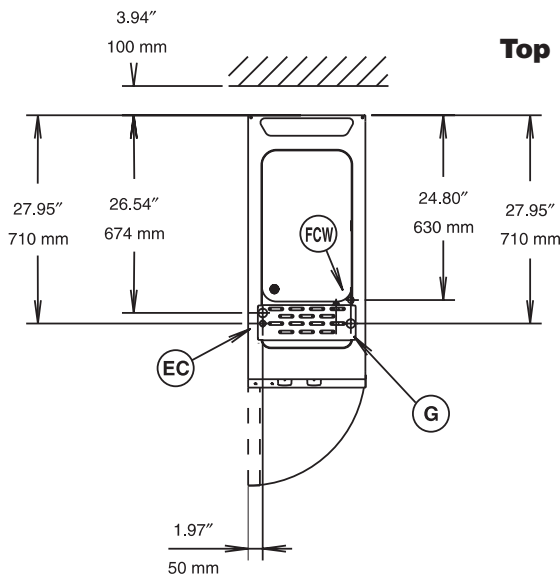

**EC** = Electrical connection  
**G** = Gas connection  
**FCW** = Filtered Cold Water Inlet

**Side View**

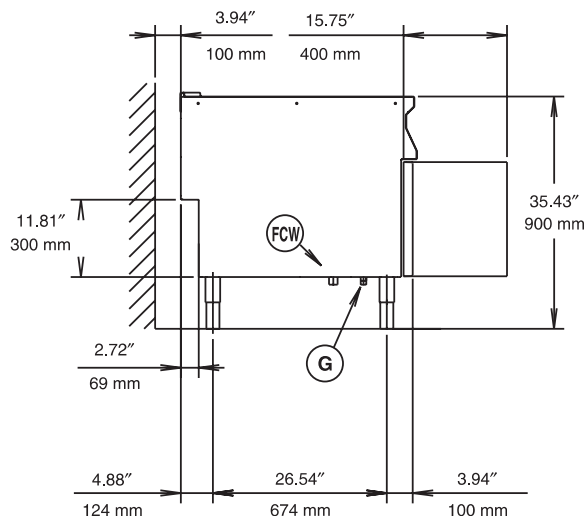

### Electric

**Supply voltage:**

200372 (NCPG1RU)

Rapid System Gas Pasta Cooker

208 V/3p/60z - 7.7 A

**Connected load:**

3 kW

### Gas (Natural or LPG)

**ISO 7/1 Gas connection**

**diameter:**

3/4" NPT

**Nominal Thermal load:**

BTU 53,000 (15.5 kW)

**Pressure**

**Natural Gas:**

4" w.c. (10 mbar)

**LPG:**

10" w.c. (25 mbar)

### Water

**Water inlet "CW" – 1/2" connection:**

**Total hardness:**

5-50 ppm

**Drain "D"**

1" connection

*Electrolux recommends the use of treated water, based on testing of specific water conditions.*

*Please refer to user manual for detailed water quality information.*

### Installation

**Clearance:**

4" (10 cm) from back.

### Capacity

**Max.:**

10.5 gal

**Min.:**

8.5 gal

### Key Information

**Net weight:**

161 lbs. (73 kg)

**Height, inch/mm:**

33-7/16" (849 mm)

**Width, inch/mm:**

15-3/4" (400 mm)

**Depth, inch/mm:**

35-7/16" (900 mm)

**Shipping weight:**

194 lbs. (88 kg)

**Shipping width:**

19" (480 mm)

**Shipping height:**

44.1" (1120 mm)

**Shipping depth:**

41" (1040 mm)

**Shipping volume:**

19.8 cu. ft. (0.56 m<sup>3</sup>)

**Pasta Solutions  
Free-standing, Single-well Pasta Cooker – Gas Rapid System**

The company reserves the right to make modifications to the products without prior notice. All information correct at time of printing.