

# YARD-MAN

OUTDOOR POWER EQUIPMENT  
for all seasons



Spring



Summer



Fall



Winter

# Owner's Manual

- ASSEMBLY
- OPERATION
- MAINTENANCE

**IMPORTANT:**  
Read Safety Rules and  
Instructions Carefully

## 8 H.P. SHREDDER

Thank you for purchasing an American-built product.

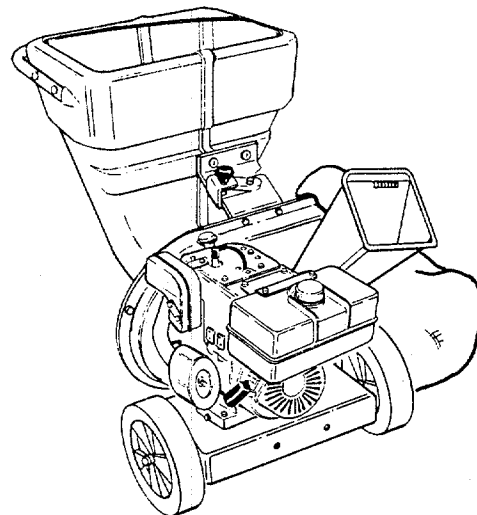

**Model Number  
244-648D401**

**WARNING:** This unit is equipped with an internal combustion engine and should not be used on or near any unimproved forest-covered, brush-covered or grass-covered land unless the engine's exhaust system is equipped with a spark arrester meeting applicable local or state laws (if any). If a spark arrester is used, it should be maintained in effective working order by the operator.

In the State of California the above is required by law (Section 4442 of the California Public Resources Code). Other states may have similar laws. Federal laws apply on federal lands. A spark arrester for the muffler is available through your nearest engine authorized service dealer or contact service department, P.O. Box 368022, Cleveland, Ohio 44136-9722.

# SAFETY RULES



**WARNING: TO REDUCE THE POTENTIAL FOR ANY INJURY, COMPLY WITH THE FOLLOWING SAFETY INSTRUCTIONS. FAILURE TO COMPLY WITH THE INSTRUCTIONS MAY RESULT IN PERSONAL INJURY.**

## TRAINING

- Read this owner's manual carefully in its entirety before attempting to assemble or operate this machine. Be completely familiar with the controls and the proper use of this machine before operating it. Keep this manual in a safe place for future and regular reference and for ordering replacement parts.
- Children must never be allowed to operate this equipment.
- No one should operate this unit while intoxicated or while taking medication that impairs the senses or reactions.
- This equipment should never be operated in the vicinity of children, pets or other persons.
- Never run your machine in an enclosed area as the exhaust from the engine contains carbon monoxide, which is an odorless, tasteless and deadly poisonous gas.
- Never place your hands or any part of your body or clothing inside the feeding chamber, discharge chute, or near any moving part while the machine or engine is running.
- If it is necessary for any reason to inspect or repair the feeding chamber or any part of the machine where a moving part can come in contact with your body or clothing, stop the machine, allow it to cool, disconnect the spark plug wire from the spark plug and move it away from the spark plug before attempting such inspection or repair.

## PREPARATION

- Wear safety glasses provided with your unit while operating the shredder to prevent injury from any material which may be ejected out of the openings.
- Wear proper apparel. Avoid wearing loose fitting clothing. Wear gloves when handling material.
- **HANDLE GASOLINE WITH CARE** as it is an extremely flammable fuel.
- Check the fuel before starting the engine. Do not fill the fuel tank indoors, while the engine is running, or while the engine is still hot. Turn the unit off and let the engine cool before refueling.
- Fuel your shredder in a clean area. Do not smoke while refueling.
- Fuel tank cap must be secure at all times except during refueling.
- Avoid spilling gasoline or oil. Wipe the unit clean of any spilled fuel or oil.
- Store fuel and oil in approved containers, away from heat or open flame, and out of reach of children.
- This machine should be operated only upon a level surface.
- Assure that all screws, nuts and bolts and other fasteners are properly secured.

## OPERATION

- When feeding shreddable material into this equipment, be extremely careful that pieces of metal, rocks, bottles, cans or other foreign objects are not included. Personal injury or damage to the machine could result.

- If the cutting mechanism strikes any foreign object or if your machine should start making an unusual noise or vibration, immediately stop the engine, disconnect the spark plug wire from the spark plug and move it away from the spark plug. Allow the machine to stop and take the following steps:
  - Inspect for damage.
  - Replace or repair any damaged parts.
  - Check for any loose parts and tighten to assure continued safe operation.
- The engine must be kept clean of debris and other accumulations.
- Do not allow an accumulation of processed material to build up in the discharge area as this will prevent proper discharge and can result in kick-back from feed opening.
- Never place your hands or any other part of your body or clothing inside the feeding chamber, discharge chute or near any moving part while the engine is running.
- Keep all guards and deflectors in place and in good working condition to assure continued safe operation.
- Always stand clear of the discharge area when operating this machine.
- Keep your face and body back from the feed opening to avoid accidental bounce back of any material.
- Do not over-reach. Keep proper balance and footing at all times.
- The engine governor settings on your machine must not be altered, changed, or tampered with. The governor controls the maximum safe operating speeds and protects the engine and all moving parts from damage caused by overspeed.
- Do not transport machine while engine is running.
- Do not operate engine if air cleaner or cover directly over carburetor air intake is removed, except for adjustment. Removal of such parts could create a fire hazard.

## MAINTENANCE AND STORAGE

- When this equipment is stopped for servicing, inspection, storage or to change an accessory, make sure the spark plug wire is disconnected from the spark plug and moved away from the spark plug. The machine should be allowed to cool down before making such inspection, adjustments, service, etc. Maintain your machine with care and keep it clean for the best and continued safe operation.
- Do not use flammable solutions to clean the air filter.
- When not in use, your machine should be stored out of the reach of children. Keep where gasoline fumes will not reach an open flame or spark. For long periods of storage, refer to the "Off-Season Storage" section of this manual.

# ASSEMBLY INSTRUCTIONS

**IMPORTANT:** This unit is shipped WITHOUT GASOLINE or OIL. After assembly, see operation section of this manual for proper fuel and engine oil recommendations.

**NOTE:** To determine right and left hand sides of your chipper-shredder, stand behind and face the hopper (engine is at the front of the unit).

Your chipper-shredder has been completely assembled at the factory, except for the chute deflector and the catcher bag. A pair of safety glasses are also included in the carton.

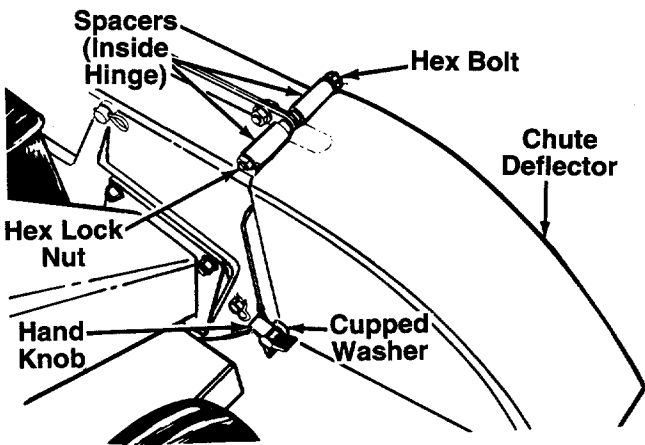

FIGURE 1.

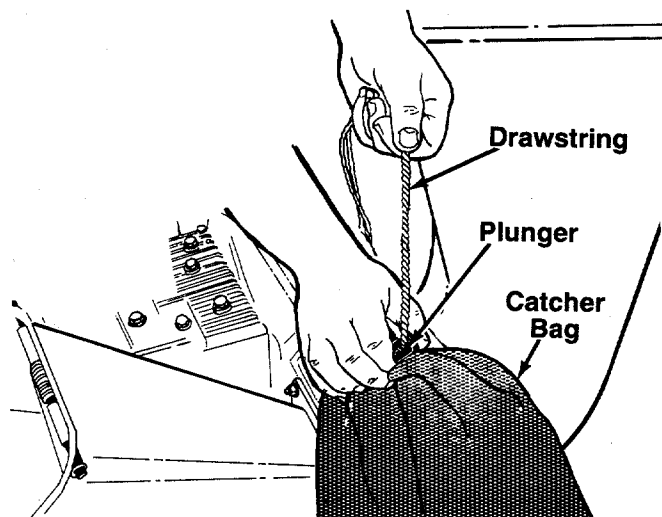

FIGURE 2.

## TO REMOVE CHIPPER-SHREDDER FROM CARTON

Cut the corners of the carton. Remove all packing inserts. Roll chipper-shredder out of the carton. Make certain all parts, literature and the safety glasses have been removed before the carton is discarded.

## TOOLS REQUIRED FOR ASSEMBLY

(2) 7/16" or Adjustable Wrenches

## HOW TO SET-UP YOUR CHIPPER-SHREDDER



**WARNING:** Make certain the spark plug wire is disconnected and moved away from the spark plug before assembling the chipper-shredder.

## ATTACHING THE CHUTE DEFLECTOR

1. Remove the hand knobs and cupped washers from each side of the discharge opening on the left side of the shredder.
2. Remove the hex lock nut, two spacers and hex bolt from inside the hinge on top of the discharge opening. Do not remove one spacer from the hex bolt.
3. Place the chute deflector in position on the discharge opening. Insert bolt through hinge on chute deflector and housing (spacer fits inside hinge).
4. Place second spacer over the hex bolt, inside the other part of hinge. Secure with hex lock nut. Tighten securely.
5. Secure both sides of the chute deflector to the housing using hand knobs and cupped washers (cupped side of washers go against chute deflector).

## ATTACHING THE CATCHER BAG

Your chipper-shredder is equipped with a catcher bag to catch the shredded material.

To attach bag, place bag opening over the chute deflector so it completely covers chute opening. Depress plunger on drawstring, pull on drawstring until bag is tight around chute opening. Release plunger to lock it into position. See figure 2.

# OPERATION

## KNOW YOUR SHREDDER

READ THIS OWNER'S MANUAL AND SAFETY RULES BEFORE OPERATING YOUR SHREDDER. Compare the illustrations with your shredder to familiarize yourself with the location of various controls and adjustments. Save this manual for future reference.

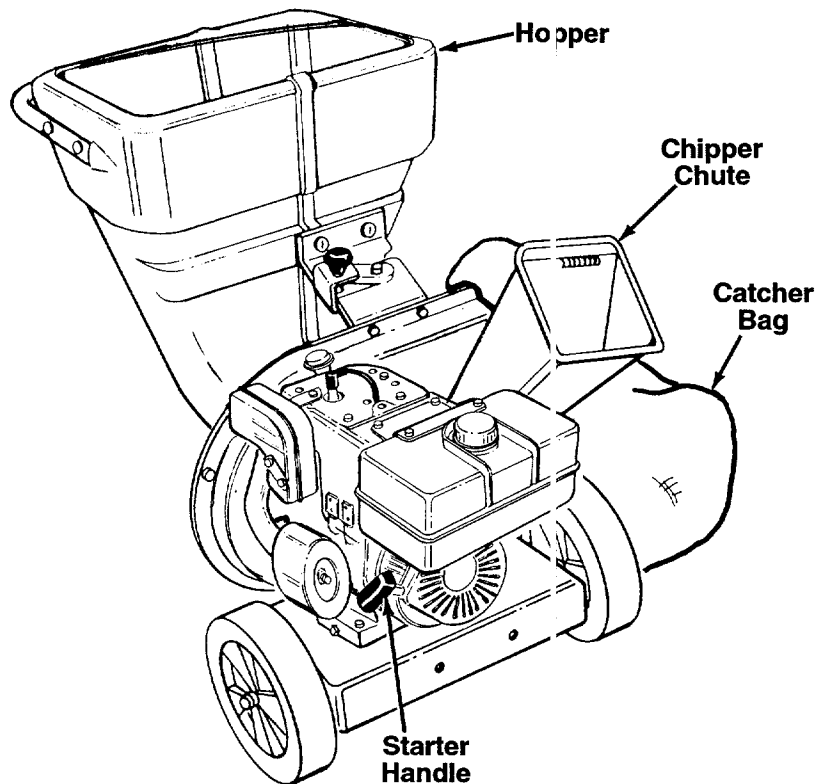

FIGURE 3.

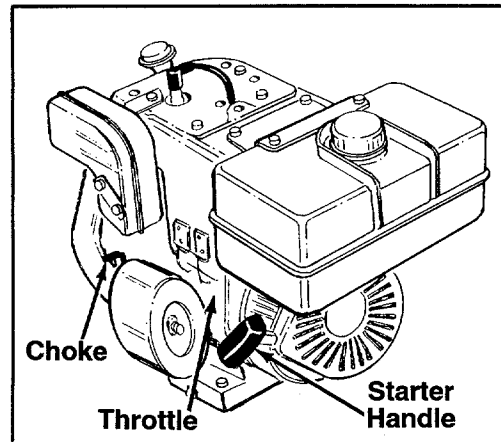

FIGURE 4.

## OPERATING CONTROLS (See figure 3 and 4)

**RELEASE HANDLE**—Used to release the hopper when lowering to the ground.

**CHOKE LEVER**—Used to enrich the fuel mixture in the carburetor when starting a cold engine.

**STARTER HANDLE**—Used to manually start the engine.

**THROTTLE CONTROL**—Controls engine speed and stops the engine.

The operation of any shredder can result in foreign objects being thrown into the eyes, which can result in severe eye damage. Always wear safety glasses or eye shields. We recommend wide vision safety mask for over spectacles or standard safety glasses.



## BEFORE STARTING

1. Place the shredder on a firm, level surface.
2. Attach spark plug wire to spark plug.
3. Service engine with gasoline and oil as instructed in the separate engine manual packed with your shredder.
4. Open fuel shut-off valve (if so equipped).

**NOTE:** Check the fuel level periodically to avoid running out of gasoline while operating the chipper-shredder. If the unit runs out of gas as it is shredding or chipping, it may be necessary to unclog the unit before it can be restarted. Refer to "Removing the Flail Screen" on page 7.

## TO START ENGINE



**WARNING:** Be sure no one other than the operator is standing near the shredder while starting or operating.

1. Place the throttle control lever in FAST position. See figure 4.
2. Move choke lever to CHOKE position (a warm engine may not require choking).
3. Grasp starter handle (see figure 4) and pull rope out slowly until engine reaches start of compression cycle (rope will pull slightly harder at this point). Let the rope rewind slowly.
4. Pull rope with a rapid, continuous, full arm stroke. Keep a firm grip on starter handle. Let rope rewind slowly. Do not let starter handle snap back against starter.
5. Repeat preceding instructions 3 and 4 until engine fires. When engine starts, move choke lever on engine halfway between CHOKE and RUN.
6. Move throttle control to IDLE position for a few minutes warm-up. Move choke lever to RUN position as engine warms up.

**NOTE:** In order to idle smoothly, a new engine may require 3 to 5 minutes running above slow idle speed. Idle speed has been adjusted to be correct after this break-in period.

### TO STOP ENGINE

1. Move throttle control lever to STOP position.
2. Disconnect spark plug wire and move away from spark plug to prevent accidental starting while equipment is unattended.
3. Close fuel shut-off valve (if so equipped) when unit is not in use to prevent fuel leakage.

### HOW TO USE YOUR SHREDDER

Do not attempt to shred or chip any material other than vegetation found in a normal yard (i.e., branches, leaves, twigs, etc.).



**WARNING:** The shredder discharges material with considerable velocity. Keep away from the area around the chute deflector. Always stop the engine and disconnect the spark plug wire when removing or attaching the bag, when changing containers or when removing the shredded material, wear safety glasses and gloves whenever using your shredder.

The shredder is designed for three different methods of operation.

1. Leaves and small branches up to 1/2" diameter can be fed into the hopper when it is in the raised position. See figure 5. If it becomes necessary to push material into the shredder, use a small diameter stick—NOT YOUR HANDS. The stick cannot exceed 1/2" in diameter so it will be ground up if it gets into the impeller assembly.



**WARNING:** Do not put material larger than 1/2" in diameter into the hopper. Material up to a maximum of 3" in diameter material may be fed into the chipper chute. Do not attempt to shred or chip any material larger than 3" in diameter. Personal injury or damage to the machine could result.

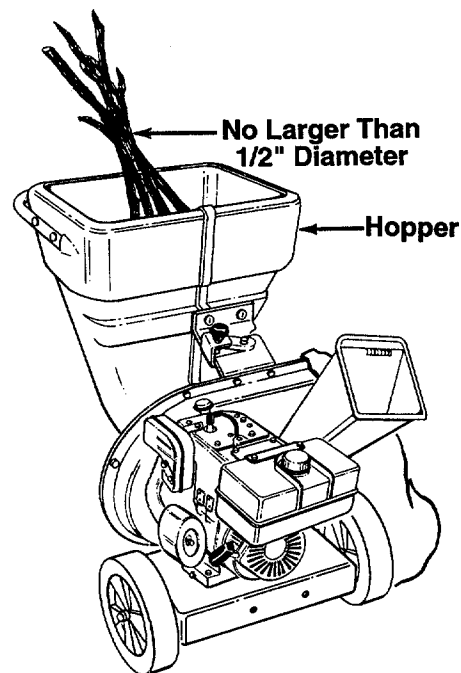

FIGURE 5.

2. Leaves and small twigs can be raked into the shredder when the hopper assembly is lowered to the ground. See figure 6.

To lower the hopper assembly to the ground, use one hand to grasp the top of the hopper assembly. Push down on the release handle, and pivot the hopper assembly to the right. See figure 7.

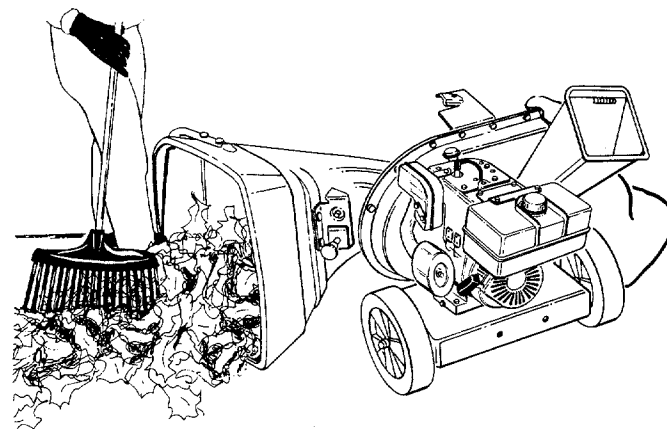

FIGURE 6.

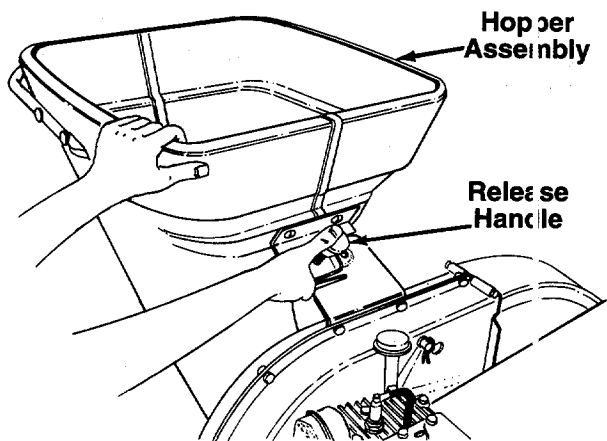

FIGURE 7.

3. Bulky material, such as stalks or heavy branches, **up to 3" in diameter** should be fed into the chipper chute. See figure 8.

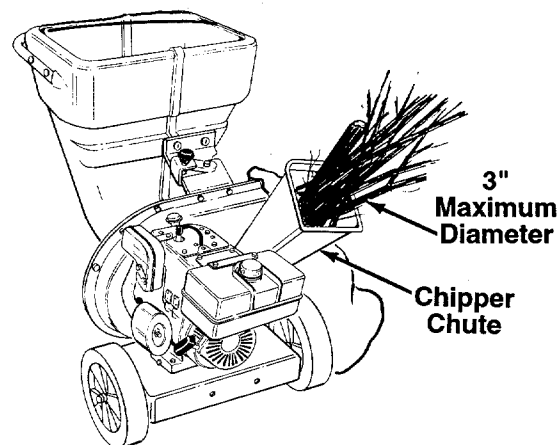

FIGURE 8.

**IMPORTANT:** There is a flail screen located inside the housing in the discharge area. If the flail screen becomes clogged, remove and clean as instructed in the Maintenance section below.

For best performance, it is important to keep the shredding blade and the chipper blades sharp. Refer to Maintenance section, page 7. If the composition of the material being discharged changes (becomes stringy, etc.) or if the rate at which the material is discharged slows down considerably, it is likely that the shredding blade and/or chipper blades are dull and need to be sharpened or replaced.



**WARNING:** Make certain the chipper chute door is closed when not in use.

## MAINTENANCE



**WARNING:** Always stop engine and disconnect spark plug wire before cleaning, lubricating or performing any repairs or maintenance.

### LUBRICATION

Lubricate the pivot points on the release handle, hopper assembly, chute deflector and chipper chute once a season using a light oil.

### ENGINE

Refer to the separate engine manual for engine maintenance instructions.

Maintain **engine oil** as instructed in the separate engine manual packed with your unit. Read and follow instructions carefully.

Service **air cleaner** every 25 hours under normal conditions. Clean every few hours under extremely dusty conditions. Poor engine performance and flooding usually indicates that the air cleaner should be serviced. To service the air cleaner, refer to the separate engine manual packed with your unit.

The **spark plug** should be cleaned and the gap reset once a season. Spark plug replacement is recommended at the start of each season; check engine manual for correct plug type and gap specifications.

**Clean the engine** regularly with a cloth or brush. Keep the cooling system (blower housing area) clean to permit proper air circulation which is essential to engine performance and life. Be certain to remove all dirt and combustible debris from muffler area.

### CLEANING

The shredder may be cleaned by running water from a hose through the hopper assembly and chipper chute with the engine running. Allow the shredder to dry thoroughly.

Wash the bag periodically with water. Allow to dry thoroughly in the shade. Do not use heat.

### REMOVING THE FLAIL SCREEN

If the discharge area becomes clogged, remove the flail screen and clean area as follows.

1. Stop the engine, make certain the shredder has come to a complete stop and disconnect spark plug wire from the spark plug before unclogging the chute.
2. Loosen the two hand knobs on each side of the chute deflector. Lift the chute deflector up, and tie it out of the way.
3. Remove two hairpin clips from the clevis pins which extend through the housing. Remove the clevis pins. Lift the flail screen from inside the housing. See figure 9.
4. Clean the screen by scraping or washing with water. Reinstall the screen.

**NOTE:** Be certain to reassemble the flail screen with the curved side down as shown in figure 9.

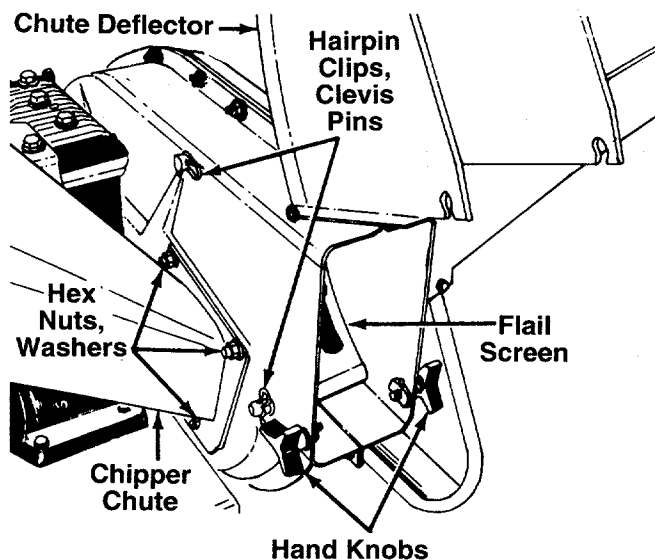

**FIGURE 9.**

### SHARPENING OR REPLACING CHIPPER BLADES

1. Disconnect spark plug wire and move it away from spark plug.
2. Remove the flail screen as instructed in previous section.
3. Remove the chipper chute by removing three hex nuts and washers. A 1/2" wrench is required. See figure 9.

**NOTE:** When reassembling, the cupped washer goes on the bottom of the chipper chute with the cupped side against the chute.

4. Rotate the impeller assembly by hand until you locate one of the chipper blades in the chipper chute opening. Remove the blade, using a 3/16" allen wrench on the outside of the blade and 1/2" wrench on the impeller assembly (inside the housing). See figure 10.
5. Remove the other blade in the same manner.

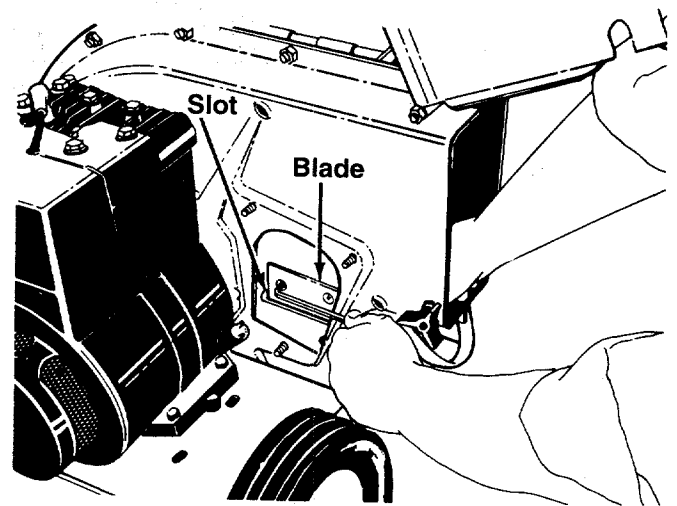

**FIGURE 10.**

Replace or sharpen blades. If sharpening, make certain to remove an equal amount from each blade. Reassemble in reverse order.

Make certain blades are reassembled with the sharp edge facing the direction shown in figure 10 (sharp edge is assembled toward the slotted opening in the impeller assembly).

### SHARPENING OR REPLACING SHREDDING BLADE

The shredding blade may be removed for sharpening or replacement as follows.

1. Disconnect spark plug wire and move it away from spark plug.
2. Lower the hopper assembly. Block up the hopper. See figure 11.
3. Remove the six hex lock nuts and flat washers from the housing weld bolts using a 1/2" wrench. Remove the hopper assembly.
4. Remove the back-up plate.

**NOTE:** When reassembling the back-up plate, make certain the single tab is at the top of the back-up plate, and the two tabs are at the bottom. Also, make certain the tabs go toward the blade.

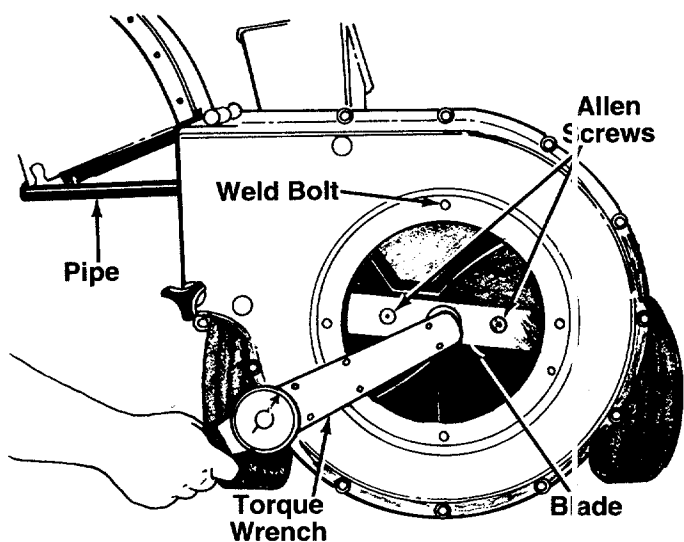

FIGURE 11.

5. Loosen the two hand knobs and cupped washers which secure the chute deflector, and raise the chute deflector.
6. Insert a 1/2" or 3/4" diameter pipe through the flail screen into the impeller assembly to keep it from turning, or remove the flail screen, and insert a piece of wood (2 x 4) into the chute opening.
7. Remove the two outside screws on the blade, using a 3/16" allen wrench and a 1/2" wrench.
8. Remove the blade by removing the center bolt, lock washer and flat washer.

**NOTE:** Use caution when removing the blade to avoid contacting the weld bolts on the housing.

When sharpening the blade, follow the original angle of grind as a guide. It is extremely important that each cutting edge receives an equal amount of grinding to prevent an unbalanced blade. An unbalanced blade will cause excessive vibration when rotating at high speeds and may cause damage to the unit.

The blade can be tested for balance by balancing it on a round shaft screwdriver or nail. Remove metal from the heavy side until it is balanced evenly. See figure 12.

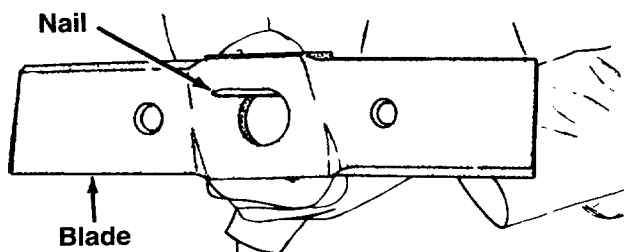

FIGURE 12.

When reassembling the blade, tighten to between 550 and 650 inch pounds, or lacking torque wrench, tighten securely.

## FLAILS

The flails, located inside the housing, may be reversed when they become dull. It is suggested that this procedure be performed by your nearest authorized dealer.

## CARBURETOR ADJUSTMENT



**WARNING:** If any adjustments are made to the engine while the engine is running (e.g. carburetor), keep clear of all moving parts. Be careful of heated surfaces and muffler.

Minor carburetor adjustment may be required to compensate for differences in fuel, temperature, altitude or load.

**NOTE:** A DIRTY AIR CLEANER WILL CAUSE ENGINE TO RUN ROUGH. BE CERTAIN AIR CLEANER IS CLEAN AND ATTACHED TO THE CARBURETOR BEFORE ADJUSTING CARBURETOR.

Do not make unnecessary adjustments. Factory settings are satisfactory for most applications and conditions. If adjustment is needed, refer to the separate engine manual packed with your shredder.

## OFF-SEASON STORAGE

The following steps should be taken to prepare your shredder for storage.

1. Clean and lubricate the shredder thoroughly as described in the lubrication instructions.
2. Refer to engine manual for correct engine storage instructions.
3. If storing in an unventilated or metal storage shed, coat metal parts with a light oil or silicone to prevent rust.
4. Store in a dry, clean area. Do not store next to corrosive materials, such as fertilizer.



## OPTIONAL EQUIPMENT

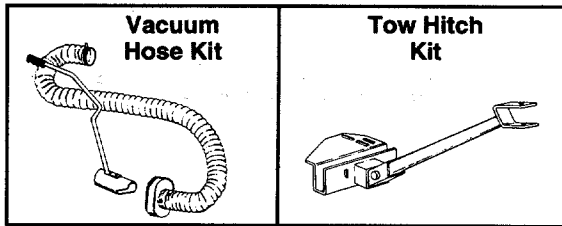

A vacuum hose kit (model 290-002-000) and a tow hitch kit (model 290-003-000) are available as optional equipment for the shredder shown in this owner's guide.

## TROUBLE SHOOTING

| PROBLEM  | POSSIBLE CAUSE(S)  | CORRECTIVE ACTION  |
|--|--|--|
| Engine fails to start  | <ol style="list-style-type: none"> <li>1. Spark plug wire disconnected.</li> <li>2. Fuel tank empty, or stale fuel.</li> <li>3. Fuel shut-off valve closed (if so equipped).</li> <li>4. Faulty spark plug.</li> </ol>   | <ol style="list-style-type: none"> <li>1. Connect wire to spark plug.</li> <li>2. Fill tank with clean, fresh fuel.</li> <li>3. Open fuel shut-off valve.</li> <li>4. Clean, adjust gap or replace.</li> </ol>   |
| Loss of power; operation erratic   | <ol style="list-style-type: none"> <li>1. Spark plug wire loose.</li> <li>2. Unit running on CHOKE.</li> <li>3. Blocked fuel line or stale fuel.</li> <li>4. Water or dirt in fuel system.</li> <li>5. Carburetor out of adjustment.</li> <li>6. Dirty air cleaner.</li> </ol> | <ol style="list-style-type: none"> <li>1. Connect and tighten spark plug wire.</li> <li>2. Move choke lever to OFF position.</li> <li>3. Clean fuel line; fill tank with clean fresh gasoline.</li> <li>4. Disconnect fuel line at carburetor to drain fuel tank. Refill with fresh fuel.</li> <li>5. Adjust carburetor.†</li> <li>6. Service air cleaner.†</li> </ol> |
| Engine overheats   | <ol style="list-style-type: none"> <li>1. Carburetor not adjusted properly.</li> <li>2. Engine oil level low.</li> </ol>   | <ol style="list-style-type: none"> <li>1. Adjust carburetor.†</li> <li>2. Fill crankcase with proper oil.</li> </ol>   |
| Too much vibration   | Loose parts or damaged impeller.   | Stop engine immediately and disconnect spark plug wire. Tighten all bolts and nuts. Make all necessary repairs. If vibration continues, have unit serviced by an authorized service dealer.  |
| Unit does not discharge  | <ol style="list-style-type: none"> <li>1. Discharge chute clogged.</li> <li>2. Foreign object lodged in impeller.</li> </ol>   | <ol style="list-style-type: none"> <li>1. Stop engine immediately and disconnect spark plug wire. Clean flail screen and inside of housing. See Maintenance section of this manual.</li> <li>2. Stop engine immediately and disconnect spark plug wire. Remove lodged object.</li> </ol>   |
| Rate of discharge slows considerably or composition of discharged material changes | Shredding blade and/or chipper blades dull.  | Sharpen or replace shredding and chipper blades.   |

†Refer to the engine manual packed with your unit.

NOTE: For repairs beyond the minor adjustments listed above, please contact your nearest authorized service dealer.



## TWO YEAR LIMITED WARRANTY

For TWO YEARS from the date of retail purchase within the United States of America, its possessions and territories, YARD-MAN will, at its option, repair or replace, for the original purchaser, free of charge, any part or parts found to be defective in material or workmanship. This warranty covers units which have been operated and maintained in accordance with the owner's instructions furnished with the unit, and which have not been subject to misuse, abuse, commercial use, neglect, accident, improper maintenance or alteration.

Normal wear parts or components thereof are subject to separate terms as noted below in the "No Fault Ninety Day Consumer Warranty" clause.

Two year consumer warranty on normal wear parts with ninety day no fault protection. All normal wear part failures will be covered on this product for a period of 90 days regardless of cause. After 90 days but within the two year warranty period, normal wear parts failures will be covered if caused by defects in material or workmanship or other component parts. Normal wear parts are defined as batteries, belts, blades, blade adapters, grass bags, rider deck wheels, and seats.

**How to obtain service:** Warranty service is available, with proof of purchase, through your local authorized service dealer. To locate the dealer in your area, please check the yellow pages or contact the Customer Service Department of YARD-MAN, P.O. Box 361131, Cleveland, Ohio 44136-0019. Phone 1 (800) YARD-MAN. The return of a complete unit will not be accepted by the factory unless prior written permission has been extended by the service department of YARD-MAN.

**Transportation charges:** Transportation charges for the movement of any power equipment unit or attachment are the responsibility of the purchaser.

**Units exported out of the United States:** YARD-MAN does not extend any warranty for products sold or exported outside of the United States of America, its possessions and territories, except those sold through YARD-MAN'S authorized channels of export distribution.

### OTHER WARRANTIES:

1. The engine or component parts thereof carry separate warranties from their manufacturers. Please refer to the applicable manufacturer's warranty on these items.
2. Log splitter pumps, valves and cylinders or component parts thereof are covered by a one year warranty.
3. All other warranties, express or implied, including any implied warranty of merchantability or fitness for a particular purpose, are hereby expressly disclaimed in their entirety.
4. The provisions as set forth in this warranty provide the sole and exclusive remedy of YARD-MAN'S obligations arising from the sales of its products. YARD-MAN will not be liable for incidental or consequential loss or damage.

**How state law relates to this warranty:** This limited warranty gives you specific legal rights, and you may also have other rights which vary from state to state. Certain disclaimers are not allowed in some states and therefore they may not apply to you under all circumstances.

**NOTE:** This warranty does not cover routine maintenance items such as lubricants, filters, blade sharpening and tune-ups, or adjustments such as brake adjustments, clutch adjustments or deck adjustments. Nor does this warranty cover normal deterioration of the exterior finish due to use or exposure.

