

# **OPERATOR'S MANUAL**

# **ENGINE DRILL**

## **EDR-210**



### **WARNING**

**READ INSTRUCTIONS CAREFULLY AND FOLLOW RULES FOR SAFE OPERATION.**

**FAILURE TO DO SO COULD RESULT IN SERIOUS INJURY.**

**ECHO POWER EQUIPMENT(CANADA)**

501 Newbold Street, London, Ontario Canada N6E 1K4

X750-004 72 3

X750409-3303

Printed in Japan 0906Ap 0389 ES

This spark ignition system complies with Canadian ICES-002.

# INTRODUCTION

ECHO Engine Drill EDR-210 is a lightweight, high performance, two-stroke engined unit designed for drilling.

This Manual provides the information necessary for operation and maintenance.

 **WARNING**  
**IMPROPER USE OR CARE OF THIS UNIT, OR FAILURE TO WEAR PROPER PROTECTION CAN RESULT IN SERIOUS INJURY. READ AND UNDERSTAND THE RULES FOR SAFE OPERATION AND ALL INSTRUCTIONS IN THIS MANUAL.**

## SAFETY AND SPECIAL INFORMATION

 **DANGER**  
The safety alert symbol accompanied by the word “DANGER” calls attention to an act or condition which **WILL** lead to serious personal injury or death if not avoided.

 **CIRCLE AND SLASH SYMBOL**  
This symbol means the specific action shown is prohibited. Ignoring these prohibitions can result in serious or fatal injury.

 **WARNING**  
The safety alert symbol accompanied by the word “WARNING” calls attention to an act or condition which **CAN** lead to serious personal injury or death if not avoided.

**NOTE**  
This enclosed message provides tips for use, care and maintenance of the unit.

 **CAUTION**  
The safety alert symbol accompanied by the word “CAUTION” calls attention to an act or condition which may lead to minor or moderate personal injury if not avoided.

**IMPORTANT**  
The enclosed message provides information necessary for the protection of the unit.

Throughout this manual and on the product itself, you will find safety alerts and helpful, information messages preceded by symbols or key words. The following is an explanation of those symbols and key words and what they mean to you.

## CONTENTS

Introduction .....	1
Safety and Special Information .....	1
Safety .....	2
Operating Techniques .....	5
Description .....	6
Assembling .....	7
Operation .....	7
Maintenance and Care .....	11
Trouble shooting .....	12
Maintenance .....	13
Storage .....	15
Specifications .....	16

Specifications, descriptions and illustrative material in this literature are as accurate as known at the time of publication, but are subject to change without notice. Illustrations may include optional equipment and accessories, and may not include all standard equipment.

# SAFETY

## **⚠ WARNING**

**ENGINE DRILL USERS RISK INJURY TO THEMSELVES AND OTHERS IF THE ENGINE DRILL IS USED IMPROPERLY, AND/OR SAFETY PRECAUTIONS ARE NOT FOLLOWED. PROPER CLOTHING AND SAFETY GEAR MUST BE WORN WHEN OPERATING ENGINE DRILL.**

## **⚠ WARNING**

**ALWAYS STOP THE ENGINE WHEN A DRILL JAM OCCURS. DO NOT ATTEMPT TO REMOVE AN OBJECT CAUSING A DRILL JAM IF THE ENGINE IS RUNNING. PHYSICAL INJURY CAN OCCUR IF A DRILL JAM IS REMOVED AND THE DRILLS START MOVING.**

## OPERATOR SAFETY

- Read this Engine drill Operator's Manual carefully. Be sure you understand how to operate this unit properly before you use it.
- Be familiar with all the controls and the proper use of the machine.
- Wear proper clothing to protect legs and other exposed parts of your body.
- Wear non-skid sole shoes. Do not wear open-toed shoes or operate unit while bare footed.
- Wear eye and hearing protection devices.
- Use caution when handling fuel. Put the caps back tightly on both the fuel can and the engine drill fuel tank.  
Move at least 3 m from the refueling point and be sure there is no leakage of fuel from the fuel tank cap or the fuel system before starting the engine.
- Operate this gasoline powered engine equipment in a well-ventilated area only.
- Start the unit on the ground with the throttle set at idle. Do not start if the drills are obstructed by the ground or any other object.
- Never allow children to use the machine.
- Do not allow anyone to hold the material you are drilling.
- Keep a firm grip on the engine drill with both hands, one hand on the front handle, the other hand on the rear handle.

- Do all drilling at full throttle speed. Drilling at less than full speed can damage the clutch by allowing it to slip.

## **⚠ WARNING**

**USE A FIRM GRIP WITH THUMBS AND FINGERS ENCIRCLING THE HANDLES. A FIRM GRIP WILL HELP YOU KEEP CONTROL OF THE ENGINE DRILL. NEVER OPERATE THE ENGINE DRILL ONLY ONE HAND OR BODILY INJURY CAN OCCUR.**

- Always carry the engine drill with the engine stopped and the HOT muffler away from your body.

## PROTECTIVE EQUIPMENT

- Always wear eye protection goggles that meet ANSI Z87.1 standards.
- Wear hearing protection. ECHO recommends that hearing protection be worn at all times.
- Dress properly! Do not wear loose clothing or jewellery, they can be caught in moving parts. Use of sturdy gloves, non-skid footwear, and safety glasses is recommended.
- While operating the machine always be sure of a secure position.

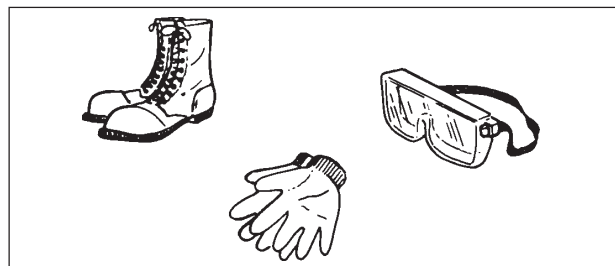

- Wear non-slip, heavy-duty work gloves to improve your grip on the engine drill handles. The gloves also help reduce the transmission of machine vibrations to your hands.

## PROTECTING OTHERS

Spectators, children, fellow workers and animals must be warned to come no nearer than 4.6 m while the engine drill is in use.

People working in the area near you should wear the same protective equipment as the operator.

## PHYSICAL CONDITION

Your judgement and dexterity may be impaired if you are ill or have taken alcohol or other substances known to affect the way you would normally function.

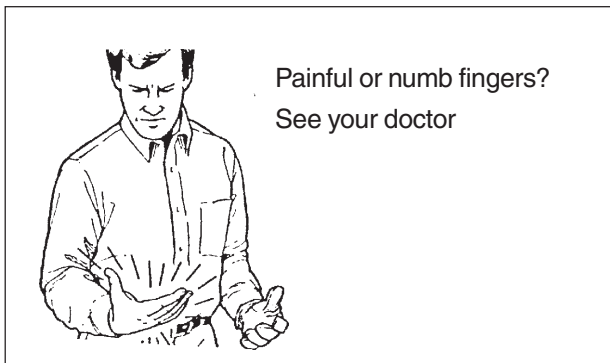
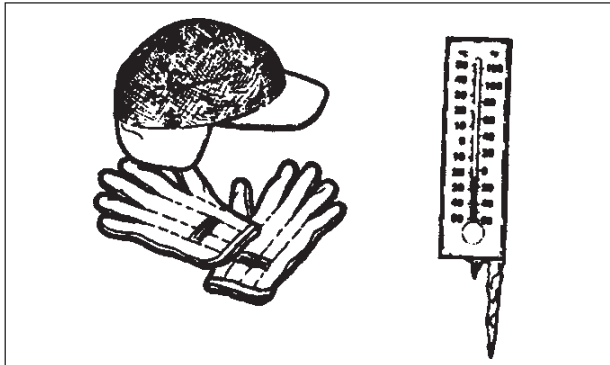

## WARNING

### PRECAUTION AGAINST VIBRATION AND COLD

IT IS BELIEVED THAT A CONDITION CALLED RAYNAUD'S PHENOMENON, WHICH AFFECTS THE FINGERS OF CERTAIN INDIVIDUALS MAY BE BROUGHT ABOUT BY EXPOSURE TO VIBRATION AND COLD. EXPOSURE TO VIBRATION AND COLD MAY CAUSE TINGLING AND BURNING SENSATIONS FOLLOWED BY LOSS OF COLOR AND NUMBNESS IN THE FINGERS. THE FOLLOWING PRECAUTIONS ARE STRONGLY RECOMMENDED BECAUSE THE MINIMUM EXPOSURE WHICH MIGHT TRIGGER THE AILMENT IS UNKNOWN.

- KEEP YOUR BODY WARM, ESPECIALLY THE HEAD, NECK, FEET, ANKLES, HANDS AND WRISTS.
- MAINTAIN GOOD BLOOD CIRCULATION BY PERFORMING VIGOROUS ARM EXERCISES DURING FREQUENT WORK BREAKS AND ALSO BY NOT SMOKING.
- LIMIT THE HOURS OF OPERATION. TRY TO FILL EACH DAY WITH JOBS WHERE OPERATING THE ENGINE DRILL OR OTHER HAND-HELD POWER EQUIPMENT IS NOT REQUIRED.
- IF YOU EXPERIENCE DISCOMFORT, REDNESS AND SWELLING OF THE FINGERS FOLLOWED BY WHITENING AND LOSS OF FEELING, CONSULT YOUR PHYSICIAN BEFORE FURTHER EXPOSING YOURSELF TO COLD AND VIBRATION.

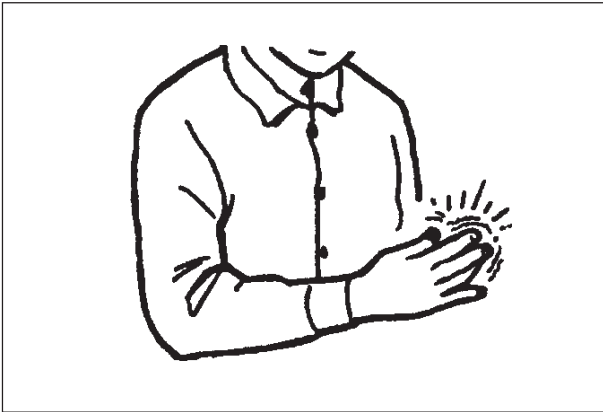
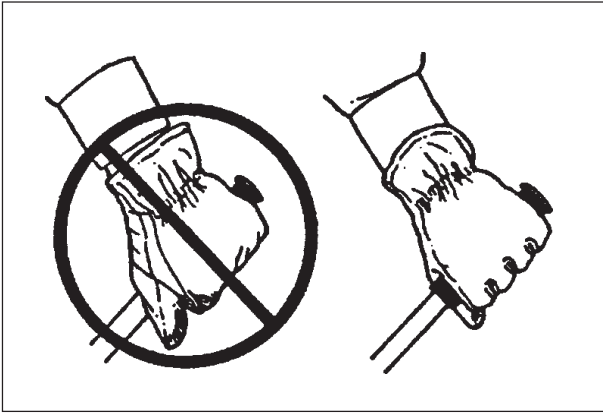

## Repetitive Stress Injuries

It is believed that over-using the muscles and tendons of the fingers, hands, arms and shoulders may cause soreness, swelling, numbness, weakness and extreme pain in those areas.

Certain repetitive hand activities may put you at a high risk for developing a Repetitive Stress Injury (RSI). An extreme RSI condition is Carpal Tunnel Syndrome (CTS), which could occur when your wrist swells and squeezes a vital nerve that runs through the area. Some believe that prolonged exposure to vibration may contribute to CTS. CTS can cause severe pain for months or even years. To reduce the risk of RSI/CTS, do the following:

- Avoid using your wrist in a bent, extended or twisted position. Instead try to maintain a straight wrist position. Also, when grasping, use your whole hand, not just the thumb and index finger.
- Take periodic breaks to minimize repetition and rest your hands.
- Reduce the speed and force with which you do the repetitive movement.
- Do exercise to strengthen the hand and arm muscles.
- See a doctor if you feel tingling, numbness or pain in the fingers, hands, wrists or arms. The sooner RSI/CTS is diagnosed, the more likely permanent nerve and muscle damage can be prevented.

# OPERATING TECHNIQUES

- When starting to drill, run the engine at full throttle.

 **WARNING**  
**BEFORE DRILLING, BE SURE TO READ AND UNDERSTAND THE ENTIRE OPERATOR'S MANUAL TO AVOID THE CHANCE OF SERIOUS INJURY.**

- When transporting or storing the machine always remove the drill bit.
- To reduce fire hazard keep engine and silencer free of debris, leaves or excessive grease.
- Handle drill with care, contacting with drills may cause injury.
- Do not force the drills and only move as quickly as the drills will allow.
- Stop the engine and disconnect from ignition cable before: - cleaning or when clearing a blockage; checking, maintenance or working on the machine.
- Handle fuel with care; it is highly flammable. Never add fuel to a machine with a running or hot engine.
- Do not attempt to repair the machine unless you are qualified to do so.
- Do not operate the machine with a damaged or excessively worn drill bit.
- Always ensure all handles and guards are fitted when using the machine. Never attempt to use an incomplete machine or one fitted with an unauthorized modification.

# DESCRIPTION

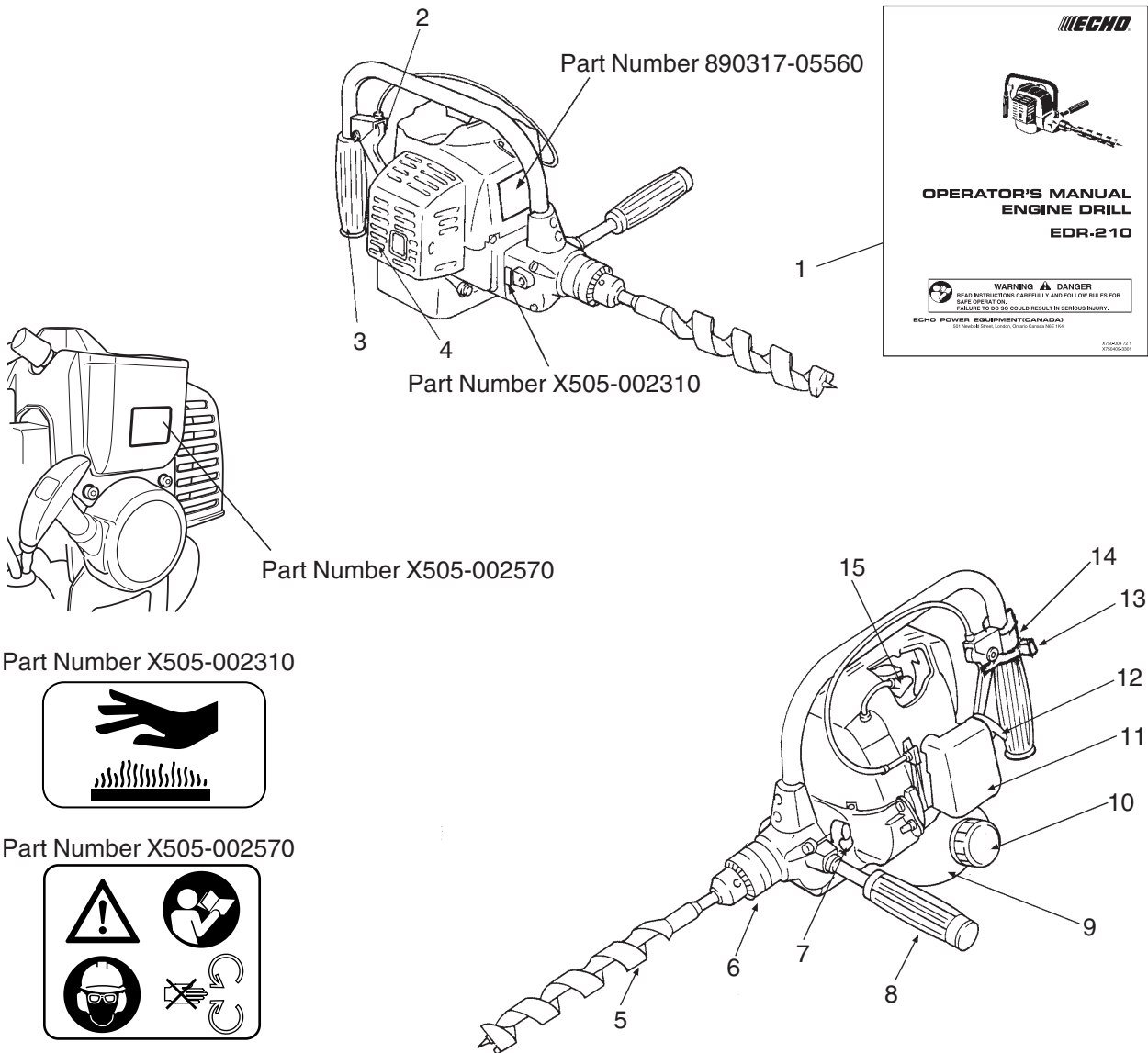

Part Number X505-002310



Part Number X505-002570

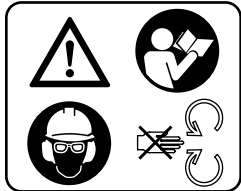

\* If a decal cannot be read, a new one can be ordered from your ECHO dealer.

1. **Operator's manual** - Included with unit. Read before operation and keep for future reference to learn proper, safe operating techniques.
2. **Throttle trigger** - Device activated by the operator's finger, for controlling the engine speed.
3. **Rear handle** - Handle located furthest from the drill bit.
4. **Silencer cover**
5. **Drill bit** - Not included with unit.
6. **Chuck**
7. **Shift lever**
8. **Front handle** - Handle located on the front gear case.
9. **Fuel tank** - Contains fuel and fuel filter.
10. **Fuel tank cap** - For closing the fuel tank.
11. **Air cleaner cover** - Covers air filter.
12. **Starter handle** - Pull handle to start the engine.
13. **Throttle trigger lockout** - Device that prevents the accidental operation of the throttle trigger until manually released.
14. **Ignition switch** - Device for allowing the engine to be started and stopped.
15. **Spark plug**



# ASSEMBLING

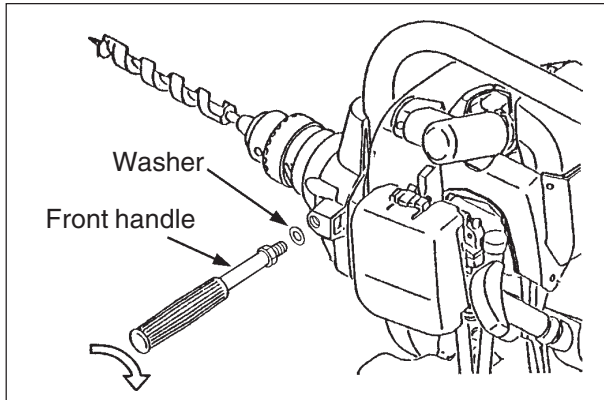

## FRONT HANDLE

- Insert the front handle to the machine, and turn clockwise.  
(TIGHTEN THE SCREW FIRMLY)
- To operate front handle with right hand, remove right plug then reverse sides when installing handle and plug.

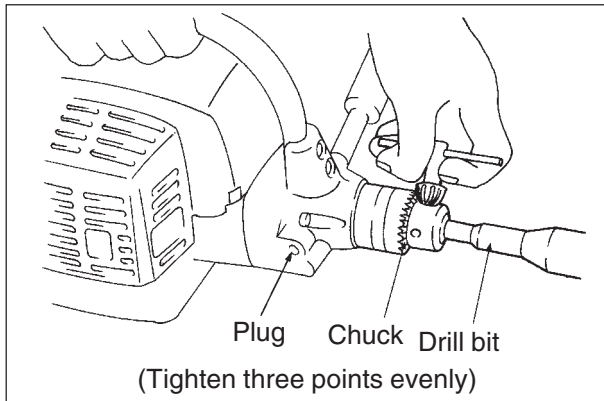

## DRILL BIT

- Insert the drill bit (not provided with unit) until it reaches the bottom of the chuck, then back it out slightly; tighten the chuck jaws evenly and completely.

### IMPORTANT

Use drill bits suited for the material being drilled and for the depth of hole required.

# OPERATION

## ⚠ WARNING

**ALTERNATIVE FUELS, SUCH AS E-20 (20 % ETHANOL), E-85 (85 % ETHANOL) OR ANY FUELS NOT MEETING ABOVE REQUIREMENTS ARE NOT APPROVED FOR USE IN ECHO 2-STROKE GASOLINE ENGINES.**

**USE OF ALTERNATIVE FUELS MAY CAUSE PERFORMANCE PROBLEMS, LOSS OF POWER, OVERHEATING, FUEL VAPOR LOCK, AND UNINTENDED MACHINE OPERATION, INCLUDING, BUT NOT LIMITED TO, IMPROPER CLUTCH ENGAGEMENT. ALTERNATIVE FUELS MAY ALSO CAUSE PREMATURE DETERIORATION OF FUEL LINES, GASKETS, CARBURETOR AND OTHER ENGINE COMPONENTS.**

Fuel Mix Chart 50 : 1

US.		METRIC	
Gasoline	Oil	Gasoline	Oil
Gallons	US. fl. oz.	L	mL
1	2.6	4	80
2	5.2	8	160
5	12.8	20	400

## CHECK UP OF NUTS AND OTHER HARDWARES

- Check up loose nuts, bolts and screws before using the unit every day.

## FUEL STATEMENT

**GASOLINE** - Use 89 Octane [(R+M)/2] (mid grade or higher) gasoline or gasohol known to be good quality.

Gasohol may contain up to 10 % Ethyl (grain) alcohol or 15 % MTBE (methyl tertiary-butyl ether). Gasohol containing methyl (wood) alcohol is **NOT** approved.

**TWO-STROKE OIL** - A two-stroke engine oil meeting ISO-L-EGD (ISO/CD 13738) and JASO M345-FC/FD Standards must be used. ECHO brand premium Power Blend X™ Universal 2-Stroke Oil meets these standards. Engine problems due to inadequate lubrication caused by failure to use an ISO-L-EGD (ISO/CD 13738) and JASO M345-FC/FD certified oil, such as ECHO premium Power Blend X™, will void the two-stroke engine warranty. (Emission related parts only are covered for two years, regardless of two-stroke oil used, per the statement listed in the Emission Defect Warranty Explanation.)

## IMPORTANT

- ECHO premium Power Blend X™ Universal 2-Stroke Oil may be mixed at 50 : 1 ratio for application in all ECHO engines sold in the past regardless of ratio specified in those manuals.
- Use of unmixed, improperly mixed, or fuel older than 90 days, (stale fuel), may cause hard starting, poor performance, or severe engine damage and void the product warranty. Read and follow instructions in the Storage section of this manual.

## HANDLING FUEL

### DANGER

**FUEL IS VERY FLAMMABLE. USE EXTREME CARE WHEN MIXING, STORING OR HANDLING OR SERIOUS PERSONAL INJURY MAY RESULT.**

- USE AN APPROVED FUEL CONTAINER.
- DO NOT SMOKE NEAR FUEL.
- DO NOT ALLOW FLAMES OR SPARKS NEAR FUEL.
- FUEL TANKS/CANS MAY BE UNDER PRESSURE.  
ALWAYS LOOSEN FUEL CAPS SLOWLY ALLOWING PRESSURE TO EQUALIZE.
- NEVER REFUEL A UNIT WHEN THE ENGINE IS HOT!
- NEVER REFUEL A UNIT WITH THE ENGINE RUNNING.
- DO NOT FILL FUEL TANKS INDOORS. ALWAYS FILL FUEL TANKS OUTDOORS OVER BARE GROUND.
- DO NOT OVERFILL FUEL TANK. IT IS NOT PERMITTED TO FILL FUEL ABOVE THE SHOULDER LEVEL OF FUEL TANK. WIPE UP SPILLS IMMEDIATELY.
- SECURELY TIGHTEN FUEL CAP AFTER REFUELING.
- INSPECT FOR FUEL LEAKAGE. IF FUEL LEAKAGE IS FOUND, DO NOT START OR OPERATE UNIT UNTIL LEAKAGE IS REPAIRED.
- MOVE AT LEAST 3 M (10 FEET) FROM REFUELING LOCATION BEFORE STARTING THE ENGINE.

### MIXING INSTRUCTIONS -

1. Fill an approved fuel container with half of the required amount of gasoline.
2. Add the proper amount of two-stroke oil to gasoline.
3. Close container and shake to mix oil with gasoline.
4. Add remaining gasoline, close fuel container, and remix.

## IMPORTANT

- Spilled fuel is a leading cause of hydrocarbon emissions. Some states may require the use of automatic fuel shut-off containers to reduce fuel spillage.
- Stored fuel ages.  
Do not mix more fuel than you expect to use in thirty (30) days, ninety (90) days when a fuel stabilizer is added.
- Stored two-stroke fuel may separate.  
ALWAYS shake fuel container thoroughly before each use.

### AFTER USE -

DO NOT store a unit with fuel in its tank. Leaks can occur. Return unused fuel to an approved fuel storage container.

### STORAGE -

Fuel storage laws vary by locality. Contact your local government for the laws affecting your area. As a precaution, store fuel in an approved, airtight container. Store in a well-ventilated, unoccupied building, away from sparks and flames.

Shoulder level

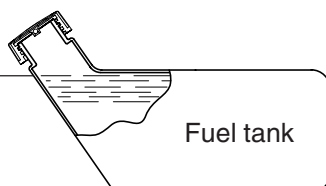

## STARTING COLD ENGINE

### WARNING

WHEN ENGINE IS STARTED, CONFIRM IF THERE IS NOT ANY ABNORMAL VIBRATION OR SOUND. IF THERE IS ABNORMAL VIBRATION OR SOUND, ASK YOUR DEALER TO REPAIR.

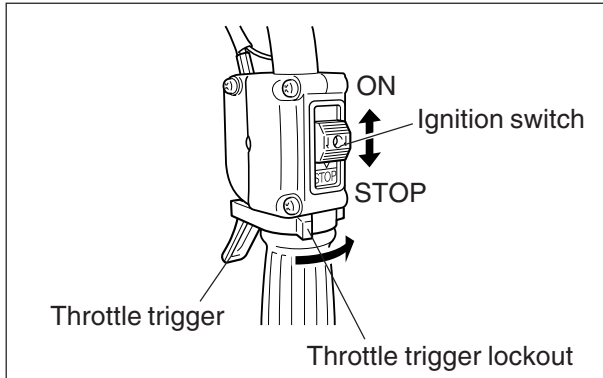

- Stand the engine upright on a level surface.
- Place ignition switch in ON (START/RUN) position.
- Push purge bulb 3 to 4 times (or until fuel is visible in fuel return line).
- Shift choke lever to close position (START).
- Pull starter handle until the engine fires.
- Shift choke lever to full open position, and if necessary, start the engine again and allow to warm up before using.
  - The clutch engages at approximately 3500 r/min. Therefore the drill bit may rotate at fast idle engine speed.

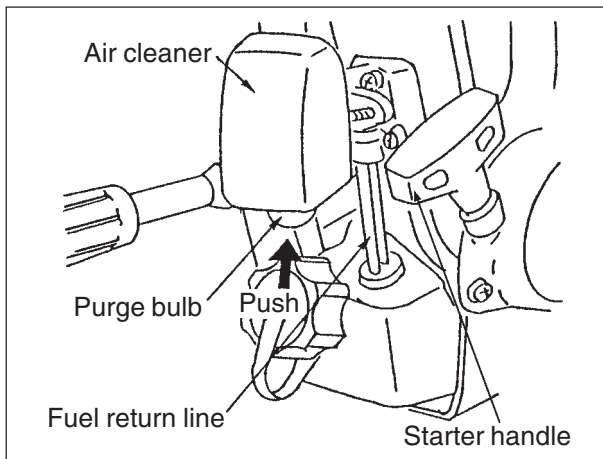

## STARTING WARM ENGINE

- Place ignition switch in ON (START/RUN) position.
- Pull starter handle until the engine fires.
  - Do not use the choke.

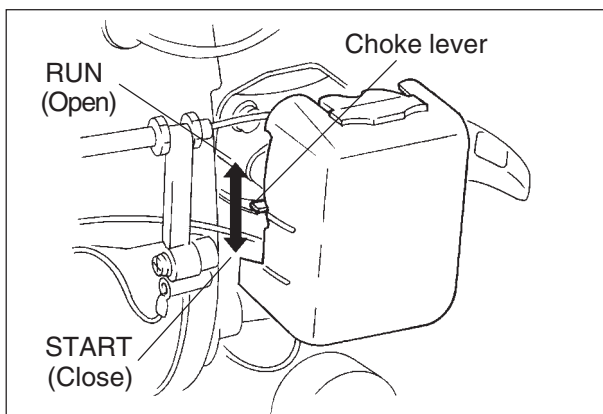

## STOPPING ENGINE

- Set throttle trigger in idle position.
- Place ignition switch in STOP position.

### NOTE

When engine does not stop, shift choke lever to close position. Check and repair ignition switch before starting the engine again.

## REVERSE ROTATION

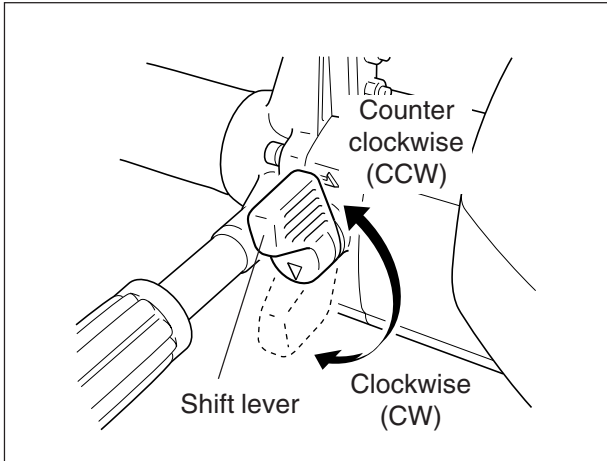

- This model is equipped with reverse rotation mechanism.
- When drilling, set shift lever down to clockwise (CW) rotation position.
- If bit is locked due to deep penetration during drilling operation, set shift lever up to counterclockwise (CCW) rotation position and operate reversed for easy pulling-out.
- When changing direction of drill rotation, operate as follows:
  - Return engine to idle.
  - Engine shift lever to CW or CCW position with a slight acceleration of the throttle trigger. To properly lock the gears in the gear case.
  - Do not operate shift lever forcibly when changing rotation direction.

### **WARNING**

- **WHEN THE DRILL CAN NOT PULL OUT FROM THE WOOD, DO NOT TRY TO PULL OUT THE DRILL BY FORCE.**
- **WHEN CHANGING THE BIT, ENSURE TO STOP THE ENGINE.**
- **AFTER A JOB, BIT AND GEAR CASING MAY BE HEATED, DO NOT TOUCH THEM WITH BARE HANDS.**

### **NOTE**

Do not shift from forward to reverse (or vice-versa) while the chuck is turning. Failure to do so may cause unit damage. Always release throttle and allow the unit to return to idle before shifting.

Do not stand close to drill or chuck with your body or clothes while operation.

When drilling, ensure that no power cable or other obstacle exist.

## MAINTENANCE AND CARE

AREA	MAINTENANCE	PAGE	BEFORE USE	MONTHLY	YEARLY	DATE MAINTENANCE PERFORMED
Air Filter	Clean/Replace	13	•			
Fuel Filter	Inspect/Clean/Replace	13		•		
Spark Plug	Inspect/Clean/Adjust/Replace	13		•		
Carburetor	Adjust	14			•	
Cooling System	Inspect/Clean	15	•			
Silencer	Inspect/Tighten/Clean	15	•			
Starter Rope	Inspect/Replace	-		•		
Drills	Inspect/Clean/Lubricate	-			•	
Fuel Leaks	Inspect	13	•			
Screws, Bolts and Nuts	Inspect, Tighten/Replace	-	•			
Fuel Line	Inspect	-		•		

### **IMPORTANT**

**Time intervals are maximum. Actual use and your experience will determine the frequency of required maintenance.  
Record dates of monthly and yearly inspections.**

# TROUBLE SHOOTING

Trouble			Cause	Remedy
Engine - hard to start - does not start				
Engine cranks	Fuel at carburetor	No fuel at carburetor	<ul style="list-style-type: none"> <li>• Fuel filter clogged</li> <li>• Fuel line clogged</li> <li>• Carburetor</li> </ul>	<ul style="list-style-type: none"> <li>• Clean or replace</li> <li>• Clean</li> <li>• Ask your ECHO dealer</li> </ul>
	Fuel at cylinder	No fuel at cylinder		
		Silencer wet with fuel	<ul style="list-style-type: none"> <li>• Fuel mixture is too rich</li> </ul>	<ul style="list-style-type: none"> <li>• Open choke</li> <li>• Clean/replace air filter</li> <li>• Adjust carburetor</li> <li>• Ask your ECHO dealer</li> </ul>
	Spark at end of plug wire	No spark at end of plug wire	<ul style="list-style-type: none"> <li>• Ignition switch off</li> <li>• Electrical problem</li> </ul>	<ul style="list-style-type: none"> <li>• Turn switch on</li> <li>• Ask your ECHO dealer</li> </ul>
	Spark at plug	No spark at plug	<ul style="list-style-type: none"> <li>• Spark gap incorrect</li> <li>• Covered with carbon</li> <li>• Fouled with fuel</li> <li>• Spark plug defective</li> </ul>	<ul style="list-style-type: none"> <li>• Adjust 0.6 to 0.7 mm</li> <li>• Clean or replace</li> <li>• Clean or replace</li> <li>• Replace plug</li> </ul>
Engine does not crank			<ul style="list-style-type: none"> <li>• Internal engine problem</li> </ul>	<ul style="list-style-type: none"> <li>• Ask your ECHO dealer</li> </ul>
Engine runs	Dies or accelerates poorly		<ul style="list-style-type: none"> <li>• Air filter dirty</li> <li>• Fuel filter dirty</li> <li>• Fuel vent blocked</li> <li>• Spark plug</li> <li>• Carburetor</li> <li>• Cooling system blocked</li> <li>• Exhaust port/spark arrester screen blocked</li> </ul>	<ul style="list-style-type: none"> <li>• Clean or replace</li> <li>• Clean or replace</li> <li>• Clean</li> <li>• Clean and adjust/replace</li> <li>• Adjust</li> <li>• Clean</li> <li>• Clean</li> </ul>

## ⚠ WARNING

- ALL ENGINE DRILL SERVICE OPERATIONS, OTHER THAN ITEMS LISTED IN THE OPERATOR'S MANUAL, SHOULD BE PERFORMED BY AN AUTHORIZED ECHO DEALER.
- FUEL VAPORS ARE EXTREMELY FLAMMABLE AND MAY CAUSE FIRE AND/OR EXPLOSION. NEVER TEST FOR IGNITION SPARK BY GROUNDING SPARK PLUG NEAR CYLINDER PLUG HOLE, OTHERWISE SERIOUS PERSONAL INJURY MAY RESULT.

# MAINTENANCE

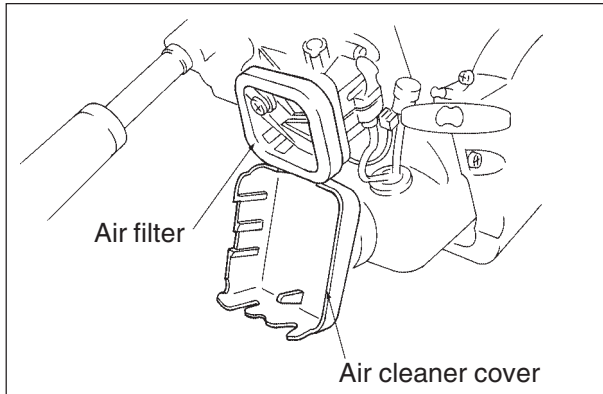

## AIR FILTER

- Clean before use.
  - Remove air cleaner cover and pull out air filter.
  - Lightly brush off dust or wash it in water and detergent.
  - Dry completely before putting it back in place.

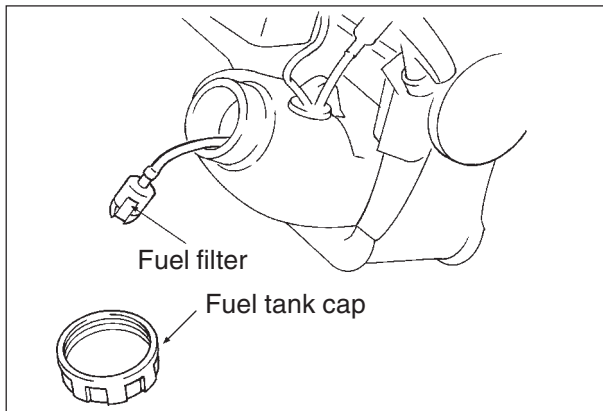

## FUEL FILTER

- Check periodically.
  - Do not allow dust to enter into fuel tank.
  - Clogged filter will cause difficulty in starting engine or poor engine performances.
  - Pick up fuel filter through fuel inlet port with a piece of steel wire or the like.
  - When filter is dirty, replace it.

## CHECK FUEL SYSTEM

- Check before every use.
- After refueling, make sure fuel does not leak or exude from around fuel pipe, fuel grommet or fuel tank cap.
- In case of fuel leakage or exudation there is a danger of fire. Stop using the machine immediately and request your dealer to inspect or replace.

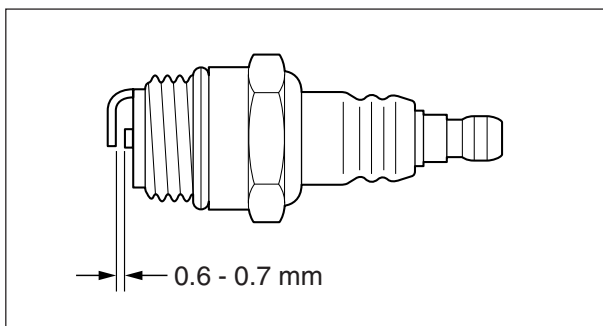

## SPARK PLUG

- Check periodically.
  - The standard spark gap is 0.6 to 0.7 mm.
  - Correct spark gap if it is wider or narrower than the standard gap.
  - If the electrodes are coated with carbon deposits replace with a new spark plug. Do not sandblast to clean. Remaining sand will damage engine.
- Fastening torque = 15 to 17 N · m

### IMPORTANT

**Do not over tighten plug.**

## REPLACEMENT OF CHUCK

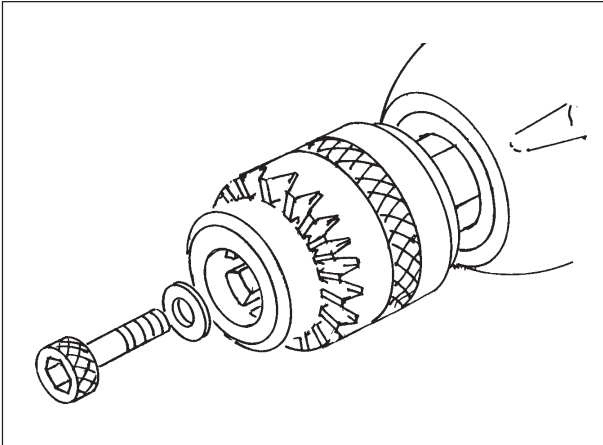

Replacement of chuck should be done in the following manner:

1. Remove bolt with hexagonal hole fixed in the driving axle.
2. Insert accessory hexagonal bar (Part Number 895412-20960) into chuck and fix.
3. Fit 19 mm spanner onto driving axle and keep it fitted.
4. Fit 10 mm box spanner onto the hexagonal bar and turn it into direction as indicated by an arrow to remove chuck.
5. Fit a new chuck in the reversed order of removing.

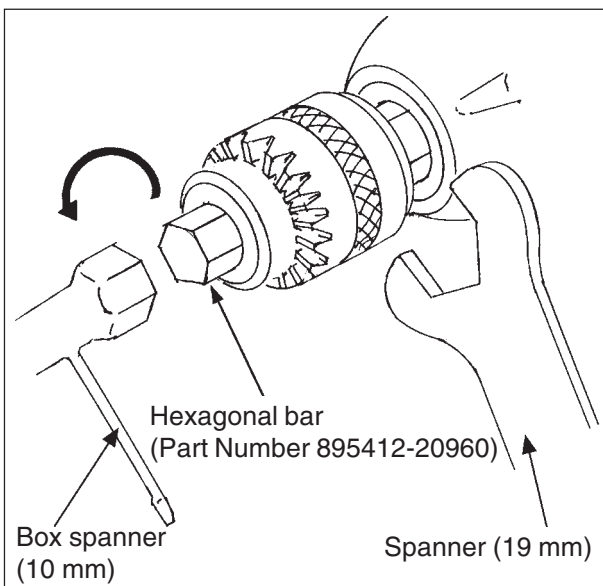

## ADJUSTING CARBURETOR (As Required)

### GENERAL INFORMATION

The idle speed adjuster screw controls the throttle opening at the idle position.

### IDLE ADJUSTMENT

Start engine and allow it to run at high idle until warm.

1. Turn the idle speed screw clockwise until drill bit begins to move.
2. Turn idle screw counterclockwise 1/2 turn or until the drill bit stops (2700 to 3300 r/min).

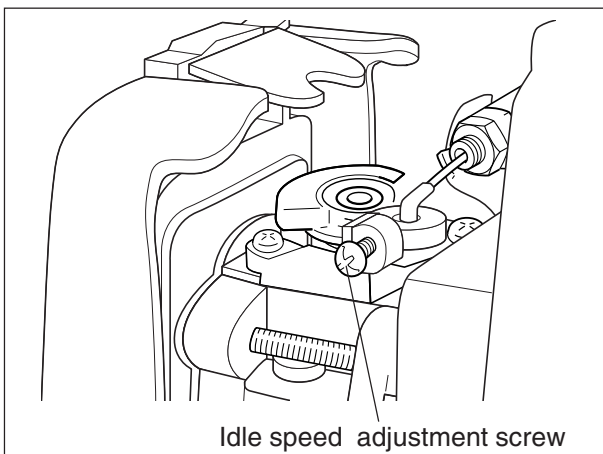

### NOTE

When there is some trouble with the carburetor, contact your dealer.



## CLEANING CYLINDER FINS (Check Periodically)

### NOTE

Clogged fins will cause poor engine cooling.

1. Carefully remove housing and clean dirt and dust from fins.
2. Reinstall housing.

## CLEANING SILENCER AND EXHAUST PORT (Check Periodically)

1. Carefully remove housing halves.
2. Remove and disassemble silencer.

### NOTE

Be careful not to scratch the cylinder or piston when cleaning the cylinder exhaust port.

3. Clean deposits from cylinder exhaust port and silencer.

## STORAGE

### LONG TERM STORAGE (Over 30 Days)

Do not store your unit for a prolonged period of time (30 days or longer) without performing protective storage maintenance which includes the following:

1. Store unit in a dry, dust free place, out of the reach of children and other unauthorized persons.
2. Place ignition switch in STOP position.
3. Remove accumulation of grease, oil, dirt and debris from exterior of unit.
4. Perform all periodic lubrication and services that are required.
5. Tighten all the screws, bolts and nuts.

6. Drain the fuel tank completely and pull the recoil starter handle several times to remove fuel from the carburetor.
7. Remove the spark plug and pour 1/2 tablespoon of fresh, clean, 2-stroke engine oil into the cylinder through the spark plug hole.
  - A. Place a clean cloth over the spark plug hole.
  - B. Pull the recoil starter handle 2 or 3 times to distribute the oil inside the engine.
  - C. Observe the piston location through the spark plug hole. Pull the recoil starter handle slowly until the piston reaches the top of its travel and leave it there.
8. Install the spark plug (do not connect ignition cable.)
9. Lubricate the drill bit with a heavy coat of oil to prevent rust.



### WARNING

**DO NOT STORE IN AN ENCLOSURE WHERE FUEL FUMES MAY ACCUMULATE OR REACH AN OPEN FLAME OR SPARK.**

### NOTE

For future reference, you should keep this operator's manual.

# SPECIFICATIONS

		<b>EDR-210</b>
Mass without drill bit	kg	4.6 (10.1 lbs )
Volume fuel tank	L	0.5 (16.9 US, fl. oz.)
Drill size	mm	32 - 178 (1.25 - 7 inch)
chuck capacity	mm	13 (0.5 inch)
speed	r/min	520
Mission reduction ratio		17.1 (regular side) 18.6 (reverse side)
lubrication		grease
External Dimensions length × width × height without drill bit	mm	430 × 320 × 265 (16.9 × 12.6 × 10.4 inch)
Engine type		Air cooled Two stroke single cylinder
engine displacement	mL(cm <sup>3</sup> )	21.2 (1.29 cu. inch)
recommended maximum engine speed	r/min	9000
recommended engine idling speed	r/min	2900
engine speed at beginning of clutch engagement	r/min	4000
carburetor		diaphragm type
ignition		flywheel magneto - CDI system
spark plug		NGK BPMR8Y
starter		recoil starter
clutch		automatic Centrifugal
Fuel mixture ratio		50:1 ratio with ECHO Power Blend X™, ISO-L-EGD (ISO/CD 13738) and JASO M345-FC/FD two-stroke, air-cooled engine oil.
gasoline		Use 89 octane unleaded. Do not use fuel containing methyl alcohol, more than 10% ethyl alcohol or 15% MTBE. Do not use alternative fuels such as E-20 or E-85.
fuel consumption at engine maximum power	L/h	0.47 (15.9 US, fl. oz.)