

OPERATOR'S MANUAL

TRIMMER/ BRUSHCUTTER SRM-400U



WARNING DANGER

READ INSTRUCTIONS CAREFULLY AND FOLLOW RULES FOR SAFE OPERATION.

FAILURE TO DO SO COULD RESULT IN SERIOUS INJURY.

ECHO, INCORPORATED
400 Oakwood Road, Lake Zurich, Illinois 60047-1564
Phone : 847-540-8400

X750-005 26 2
X750216-1602
Printed in Japan 0504rd 0419 ES

INTRODUCTION

The ECHO Trimmer/Brushcutter, model SRM-400U is lightweight, high performance gasoline powered rotary trimmer which is designed for brushcutting, weed control and grass trimming in areas which are difficult to control by any other means. The trimmer is equipped with a safety shoulder harness, and the excellent balance characteristics plus the available power, ensures comfortable operation.

This manual provides the information necessary for assembly, adjustment, operation and maintenance of your unit.

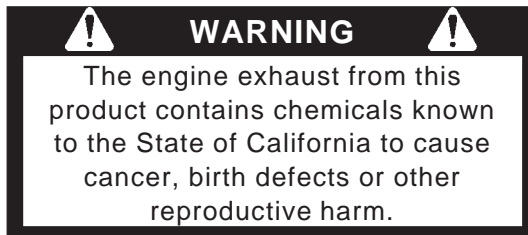

Locate this safety decal on your unit. The complete unit illustration found in the "NOMENCLATURE" section, will help you locate them. Make sure the decal is legible and that you understand and follow the instructions on them. If a decal cannot be read, a new one can be ordered from your ECHO dealer.

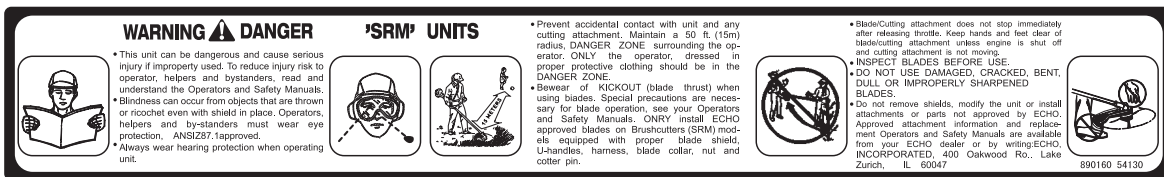

Safety decal: Part number 890160-54130

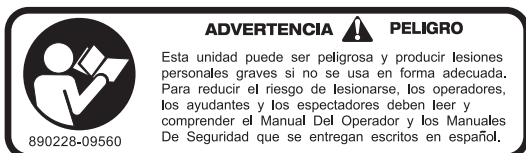

Safety decal: Part number 890228-09560



Safety decal: Part number 890177-51330

CONTENTS

RULES FOR SAFE OPERATION	3
NOMENCLATURE HAVE PARTS	4
TECHNICAL DATA	4
ASSEMBLING	5
OPERATION	7
MAINTENANCE AND CARE	16
TROUBLE SHOOTING	18
LONG TERM STORAGE	20

RULES FOR SAFE OPERATION

SAFETY INSTRUCTIONS

1. **Do Not** operate the unit when you are fatigued.
2. **Do Not** operate if other people or animals are in the work area.
3. **Do Not** operate the unit without the shield correctly in position.
4. **Do Not** operate in a confined area. Carbon monoxide exhaust gas is highly poisonous.
5. **Do Not** operate the unit while you are smoking.
6. **Always** wear eye protection goggles when operating the unit.
7. **Always** hold the unit firmly with both hands and with fingers and thumbs encircling the handles.
8. **Always** obey local ordinances regulating the use of internal combustion engines in your area.
9. **Always** use the cutting attachments as approved and supplied by ECHO Inc. for your unit.
10. **Always** remain alert when operating the unit to avoid possible injury to yourself and other people.
11. **Always** wear the shoulder harness when operating the unit.
12. **Do not** operate the unit while under the influences of drugs or alcohol.

ATTENTION

For your protection when operating this unit, comply with all Safety Rules as listed in the Operator's Manual. (Replacement manuals are available from your ECHO dealer.)

1. Do not operate unless the debris shield and safety harness are in good condition and properly installed.
2. Do not operate if other persons or animals are in the work area.
3. Do not operate without eye protection goggles available from your ECHO dealer.

WARNING DANGER

1. **Do Not** smoke while handling gasoline.
2. **Do Not** refuel a hot engine. Wait until it cools.
3. **Do Not** overfill the tank. Spilled fuel must be wiped up.
4. **Always** stop the engine when refueling.
5. **Always** remove the fuel cap slowly in order to relieve any pressure build up in the tank.
6. **Always** restart the engine at least 3 m (10 feet) away from the refueling point.
7. **Always** store gasoline in an approved container.

WARNING DANGER

SERIOUS INJURY MAY RESULT FROM THE IMPROPER USE OF STEEL BLADES. COMPLY WITH ALL SAFETY INSTRUCTIONS LISTED IN THE OPERATOR'S MANUAL AND SUPPLIED WITH THE BLADES.

1. **THE ECHO SAW TOOTH BLADE IS DESIGNED TO CUT BRUSH AND SMALL TREES.**
2. **THE ECHO 8 TOOTH ROTARY KNIFE BLADE IS DESIGNED TO CUT HEAVY WEEDS AND GRASS. TO AVOID INJURY DUE TO KICK BACK OR BLADE FRACTURE, DO NOT USE THIS BLADE TO CUT BRUSH OR TREES.**
3. **ECHO INC. WILL NOT BE RESPONSIBLE FOR THE FAILURE OF CUTTING DEVICES WHICH HAVE NOT BEEN TESTED AND APPROVED BY ECHO FOR USE WITH THIS UNIT.**

NOMENCLATURE HAVE PARTS

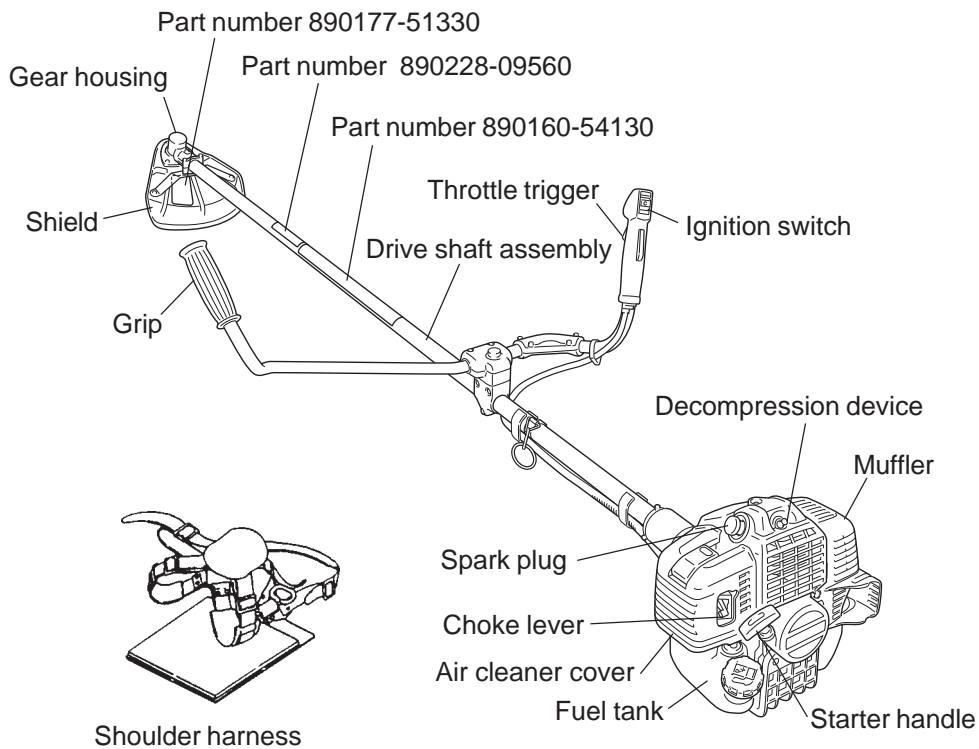

TECHNICAL DATA

			SRM-400U
Dimension	L x W x H	cm	186 x 70 x 43 (73.2 in x 27.6 in x 16.9 in)
Mass		kg	9.9 (21.8 lb): without shoulder harness and cutter head
Engine	Type Displacement Maximum revolution Carburetor Ignition Spark plug Starter Clutch	mL (cm ³) r/min	Air cooled two stroke single cylinder 42.7 (2.6 cu in) 10,000 Walbro diaphragm type WYK Flywheel magneto : CDI (Capacitor Discharge Ignition) system CHAMPION CJ-6Y Recoil starter Automatic centrifugal clutch
Fuel	Mixing ratio Tank capacity	 L	Mixture of gasoline (Unleaded, 89 octane minimum) and specially blended 50 : 1 ECHO two cycle engine oil. 1.0 (33.8 US fl oz)
Drive shaft assembly	Cutter (Option) Cutter Cutter (Option) Gear housing Lubrication Drive shaft Shield		Nylon line cutter head Circular saw, 25 cm (10 in) 8 cutter blade, 20 cm (8 in) 60 degree bevel gears, ratio 1 : 1.33 (Counterclockwise) Good quality lithium grease High tensile solid steel, 5 bearings Metal shield mounted on the gear housing for nylon line and metal blade applications.

Technical data subject to change without notice.

ASSEMBLING

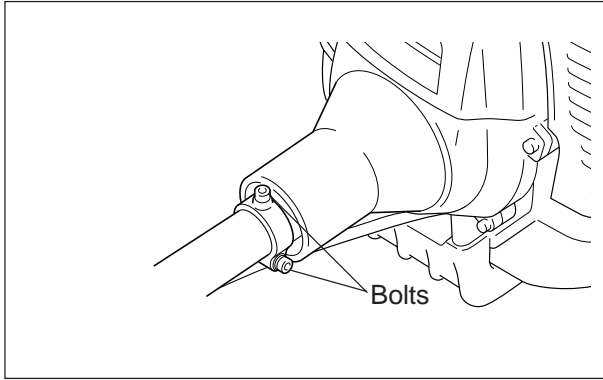

DRIVE SHAFT

- Stand engine upright on a level floor.
- Loosen bolts at drive shaft end of the engine.
- Fit drive shaft assembly ensuring that the drive shaft is correctly engaged.
- Tighten bolts to fasten drive shaft assembly.

WARNING  **DANGER**
NEVER START ENGINE WITHOUT DRIVESHAFT ASSEMBLY INSTALLED. THIS COULD RESULT IN SERIOUS INJURY.

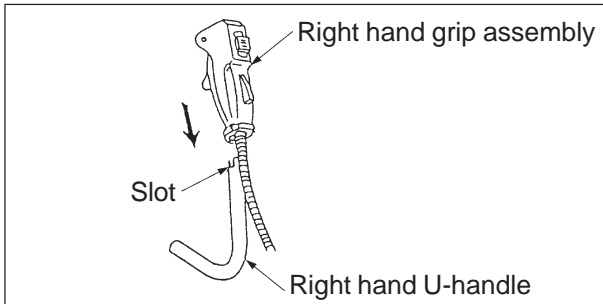

HANDLE

Insert right hand grip assembly into right hand U-handle and fit it to the slot for rotation prevention of right hand U-handle.

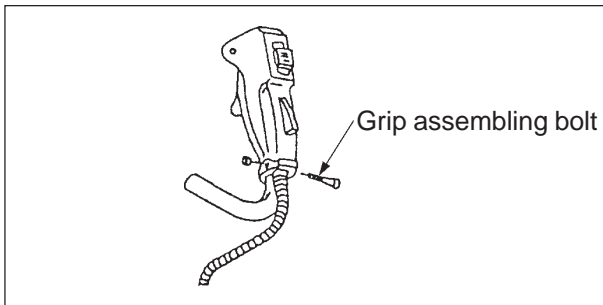

Fit grip assembling bolt and secure the grip firmly.

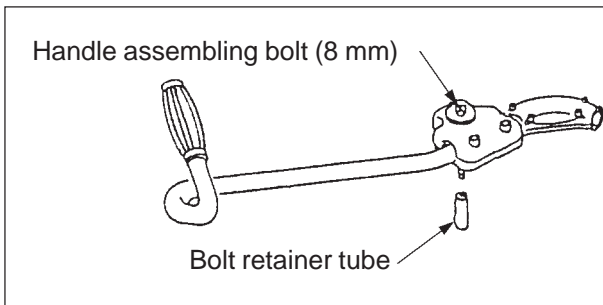

Remove bolt retainer tube from end of handle assembling bolt (8 mm).

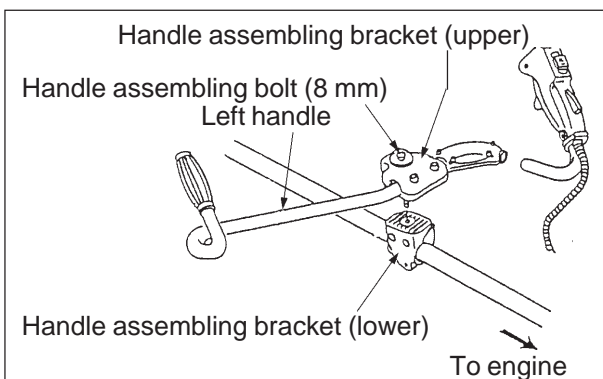

Install handle assembling bracket (upper) in handle assembling bracket (lower) and fix handle by tightening handle assembling bolt (8 mm) lightly.

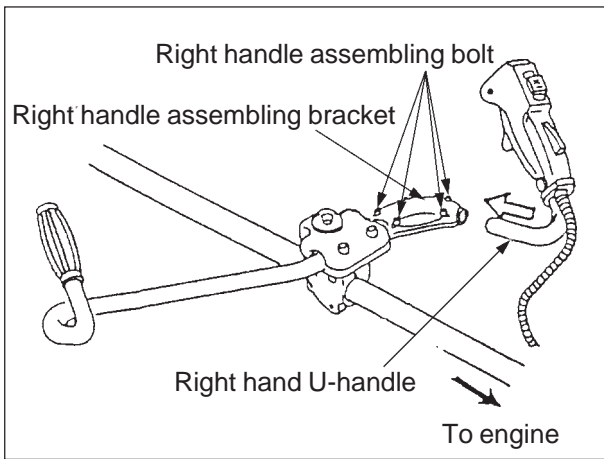

Loosen 4 right handle assembling bolts and insert right hand U-handle into right hand assembling bracket. (toward direction of arrow ⇐⇒)

Fix the right hand U-handle by tightening 4 right handle assembling bolts lightly.

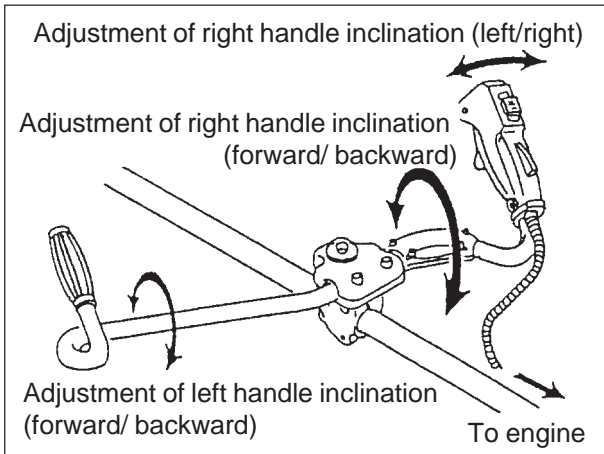

Adjust each inclination of right and left handles to adequate position (easy to operate) and tighten handle firmly assembling bolt (8 mm) and 4 right handle assembling bolts.

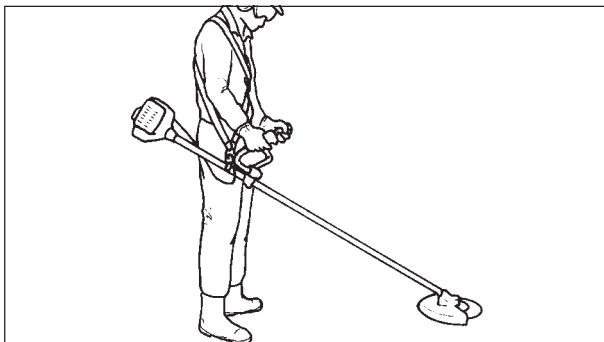

Determine "Easy to operate" position.

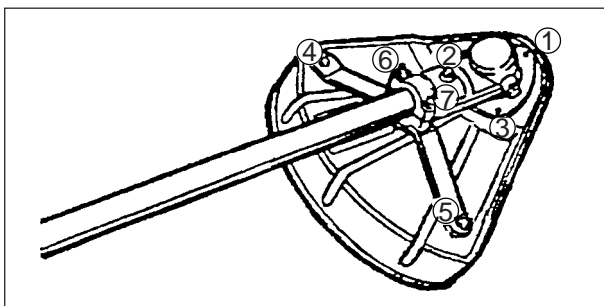

SHIELD

Fit the shield on the gear housing and tighten screws with washers (Seven points) as shown.

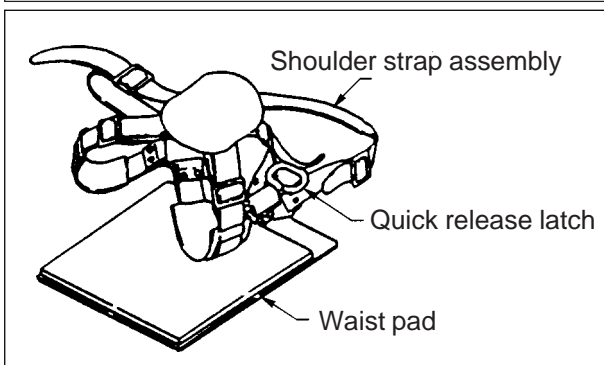

SHOULDER HARNESS

Fit the shoulder strap to the swivel hook, and adjust the length of strap and or the location clamps to maintain the cutter head parallel to the ground.

OPERATION

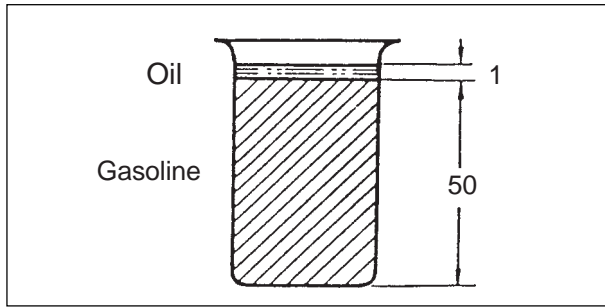

Fuel mix chart (50 : 1)

US		METRIC	
GAS	OIL	GAS	OIL
GAL	FL OZ	L	mL
1	2.6	4	80
2	5.1	8	160
5	12.8	20	400

GENERAL CHECK

Ensure that all nuts, screws and bolts installed are properly tightened.

FUEL STATEMENT

GASOLINE: Use 89 octane [(R+M)/2] gasoline or gasohol known to be good quality. Gasohol may contain maximum 10 % ethyl (grain) alcohol or 15 % MTBE (methyl tertiary-butyl ether). Gasohol containing methyl (wood) alcohol is not approved.

OIL: ECHO brand premium two-stroke 50 : 1 oil is required.

Mix oil and gasoline/gasohol according to instructions on the oil container label.

MIXING: Follow directions on the oil container.

IMPORTANT

Stored fuel ages.

Do not mix more fuel than you expect to use in thirty (30) days, ninety (90) days when a fuel stabilizer is added.

Stored two-stroke fuel may separate.

ALWAYS shake fuel container thoroughly before each use.

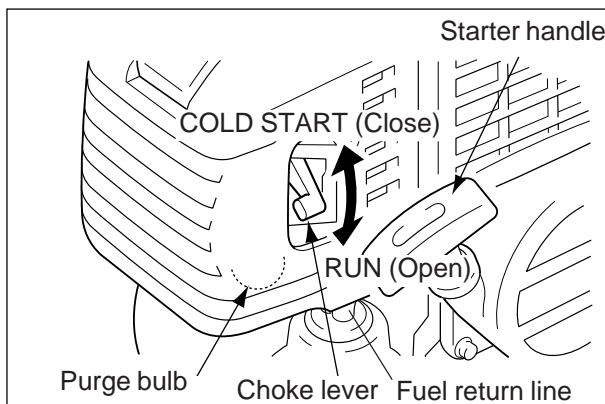
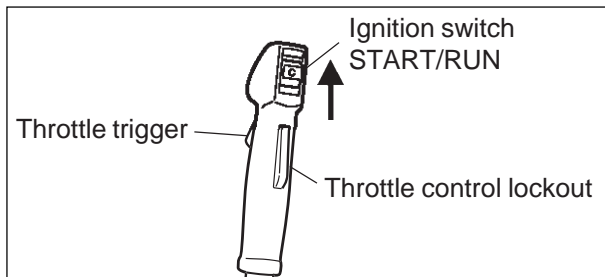
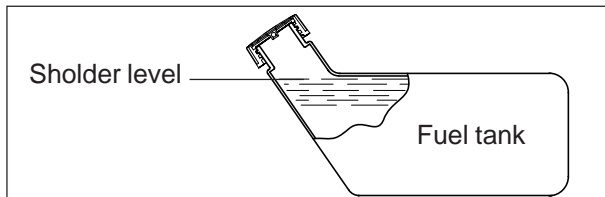

NOTE

Starter handle : Use short pulls - only 1/2 - 2/3 of starter rope for starting. Do not let starter rope snap back in. Always hold the unit firmly.

STARTING COLD ENGINE

WARNING DANGER

- **WHEN ENGINE IS STARTED, CONFIRM IF THERE IS NOT ANY ABNORMAL VIBRATION OR SOUND. IF THERE IS ABNORMAL VIBRATION OR SOUND, ASK YOUR DEALER TO REPAIR.**
- **AFTER REFUELING TIGHTEN FUEL CAP FIRMLY AND CHECK FOR LEAKAGE. IN CASE OF FUEL LEAKAGE REPAIR BEFORE STARTING OPERATION SINCE THERE IS A DANGER OF FIRE.**

- It is not permitted to fill fuel above the shoulder level of fuel tank.
- Slide switch to START/RUN position as shown.
- Push purge bulb 3 or 4 times (or until constant flow of fuel is visible in fuel return line).
- Move choke lever to COLD START (Close) position.
- Press the decompression device.
- Pull starter handle until the engine fires. Now, move choke lever to RUN (open) position, and if necessary, restart the engine again and allow to warm up for a few minutes before using.
- After idling, gradually open throttle and cutter blade will start to operate as the engine attains clutch engagement speed of 3,500 r/min approximately.

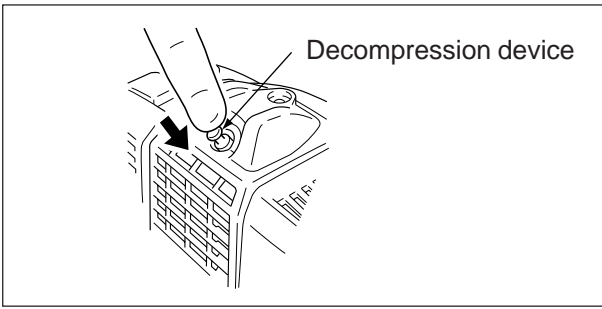

STARTING WARM ENGINE

- Press the decompression device.
- When engine is warm, start it by pulling starter handle with switch positioned at START/RUN. (Keep choke lever in RUN (open) position)
- If engine does not start in a few tries, follow same procedures as starting a cold.

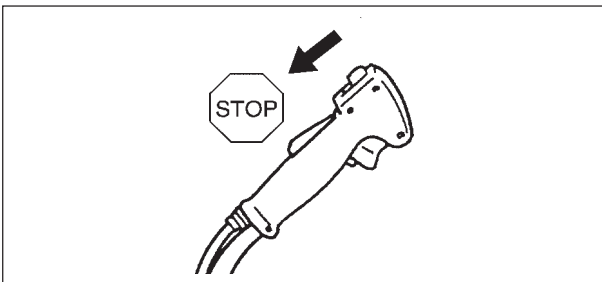
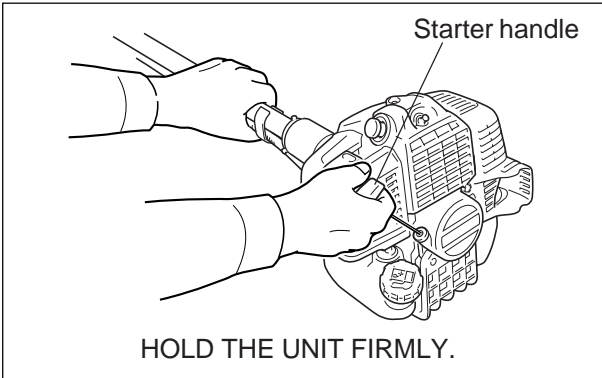

STOPPING ENGINE

- Release throttle trigger and allow to run at an idle speed.
- Slide ignition switch to “STOP” position.

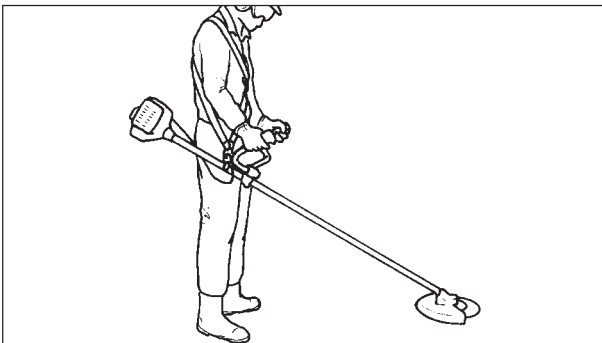

OPERATING THE TRIMMER

- Adjust handle to a convenient position for cutting as instructed on page 6.
- Allow the engine to warm up at a fast idle for a few minutes.
- Increase engine speed as necessary.
- When mowing shrubs, weeds, or grass, swing the cutter head from right to left as you move forward.
 - Avoid striking any obstruction such as rocks, stones or tree stumps which can damage the cutter head.
 - Do not cut into the ground.
 - To avoid damage to the engine, do not run the engine unloaded at full throttle.
- In the event that the cutter strikes an obstruction or is otherwise prevented from rotating in normal operation, the clutch will slip to prevent possible engine damage. In this case, stop the engine, free the cutter and then start the operation again.

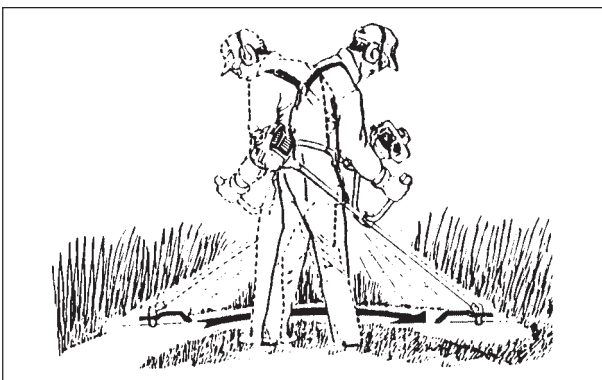

WARNING  DANGER
DO NOT ALLOW EITHER PEOPLE OR ANIMALS INTO THE WORK AREA. ALWAYS WEAR SAFETY GOGGLES WHEN CUTTING. DRESS PROPERLY - AVOID LOOSE CLOTHING. WHEN GRASS OR WEEDS HAVE CLOGGED THE CUTTER HEAD AFFECTING NORMAL OPERATION, FIRST, STOP THE ENGINE AND THEN REMOVE THE DEBRIS.

WARNING  DANGER
•BEFORE STARTING UP THE ENGINE, MAKE SURE THAT THE CUTTER BLADE IS NOT CONTACTING ANYTHING.
•WHEN TWO OR MORE OPERATORS ARE WORKING TOGETHER, ENSURE THAT A SAFE DISTANCE IS KEPT BETWEEN THEM.

OPERATING INSTRUCTIONS (METAL BLADES and OPTIONAL NYLON LINE)

Your brushcutter/trimmer, has been designed and constructed to give you years of trouble-free service and relieve you of the many back-aching tasks normally associated with grass trimming, weed control and brushcutting. Nevertheless, in common with all other power operated tools, the Owner and/or Operator has a definite responsibility to maintain the safe working condition of the unit as provided by the manufacturer, and to ensure also the safe operating procedures as prescribed by common sense and this manual. Please, therefore, read and understand the instructions as listed hereunder, and on Page 3, in order to prevent accidents and possible injury.

ECHO 2-LINE MANUAL TRIMMER HEAD (OPTION)

WARNING  DANGER
GRASS/WEED TRIMMERS CAN THROW GRAVEL, STONE, WOOD CHIPS, GLASS, AND PLASTIC OR METAL OBJECTS. THE DEBRIS SHIELD BEHIND THE TRIMMER HEAD STOPS MUCH OF THE DEBRIS, BUT CANNOT PREVENT THE OPERATOR FROM BEING STRUCK BY SOME DEBRIS. READ THE RULES FOR SAFE OPERATION IN THE OPERATOR'S MANUAL THAT YOU RECEIVED WITH YOUR ECHO TRIMMER. ALSO, FOLLOW ALL INSTRUCTIONS IN THIS INSTRUCTION SHEET.

1. Read the Operator's Manual carefully.
Be thoroughly familiar with the controls and proper use of the trimmer.
Know how to stop the unit and disengage the controls.
2. Never allow children to operate the trimmer.
3. Never allow adults to use the trimmer unless they have received proper instructions.
Be sure the operator is properly attired and wears the type of foot, leg, head, eye and ear protection recommended both in your ECHO Operator's Manual and by your ECHO Servicing Dealer.
4. Always wear eye protection that conforms to ANSI Z 87. 1-2000.

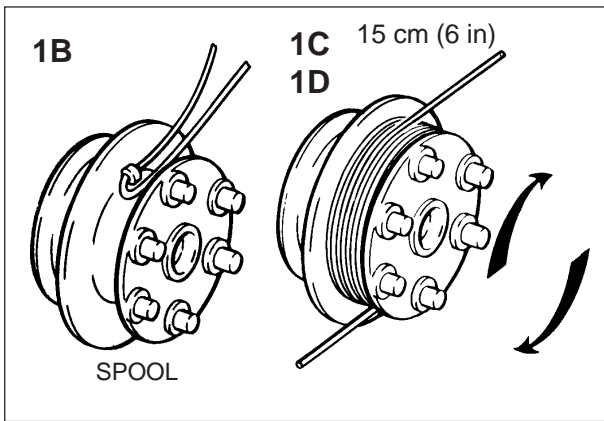

1. REPLACING LINE

- Remove spool by turning knob clockwise, "right", and separating parts.
- Thread a 6 m (20 feet) length of 2.4 mm (0.095 in) or 2.7 mm (0.105 in) ECHO line through hole in spool so that ends are the same length.
- Wind both ends of line tightly and evenly clockwise (see arrows on spool), and wind from side to side without twisting the lines.
- Secure ends of line temporarily with about 15 cm (6 in) extending out.

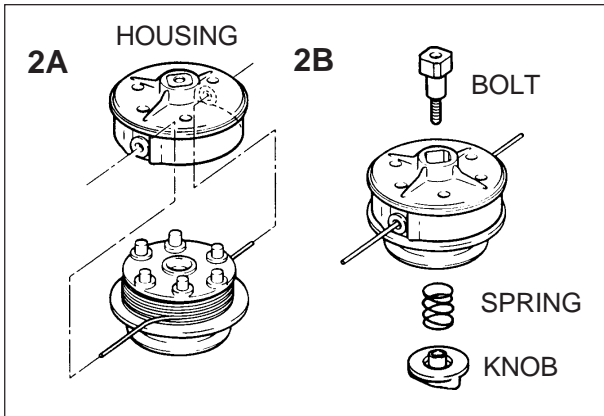

2. REPLACING SPOOL

NOTE

Keep line tight on spool.

- Snap spool into housing while pulling line through eyelets with about 15 cm (6 in) extending out.

CAUTION

Knob tightens counterclockwise, "left".

- Fasten spool to housing with shaft bolt, spring, and knob.

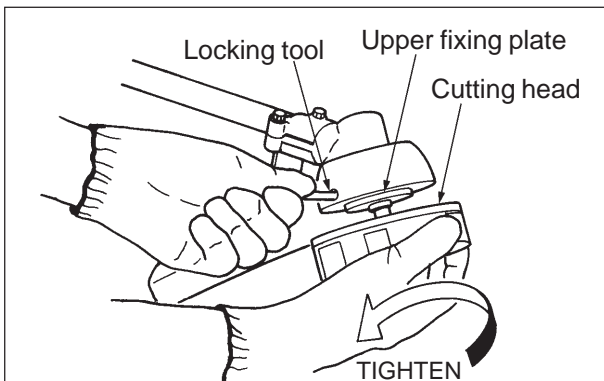

INSTALLATION OF NYLON LINE HEAD (OPTION)

Set the nylon line head to the drive shaft and tighten by turning as shown.

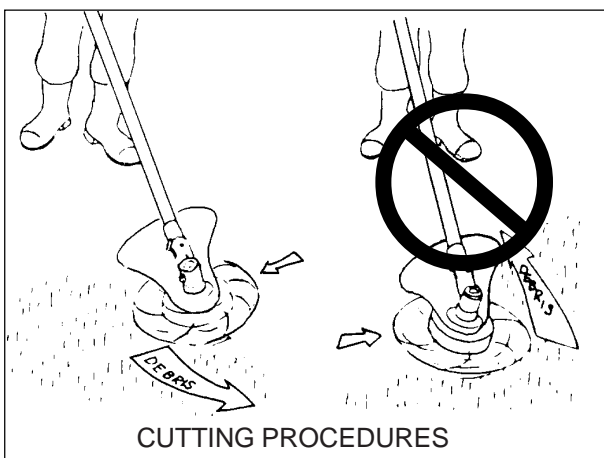

OPERATING INSTRUCTIONS NYLON LINE

- Always use the end of the line for cutting. Forcing the cutter head too close to the work will result in reduced efficiency and broken line.
- Maintain the line at the recommended length of 12.5 to 15 cm (5 to 6 in). A longer line will reduce engine speed, a shorter line may result in engine damage.
- The trimmer head rotates counterclockwise. Always cut with the head tilted to the right to deflect debris away from the operator.
- Always observe the SAFETY RULES on Page 3 when using the unit.

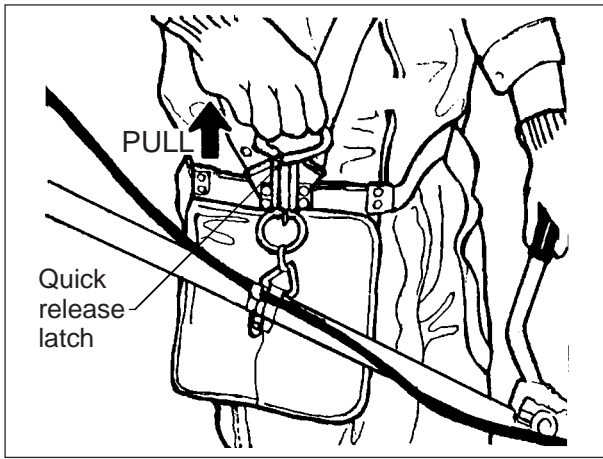

SHOULDER HARNESS

- Install the harness over the both shoulders and adjust shoulder straps so that the quick release latch rests low on the right hand side.
- Attach the trimmer/brushcutter to the harness by means of the quick release latch.
- Make some practice sweeps as with a trimmer and readjust the harness as necessary for comfort and to maintain the cutter parallel to the ground.

WARNING  **DANGER**
IN CASE OF EMERGENCY, PULL THE QUICK RELEASE LATCH TO DISCONNECT THE TRIMMER FROM THE HARNESS.

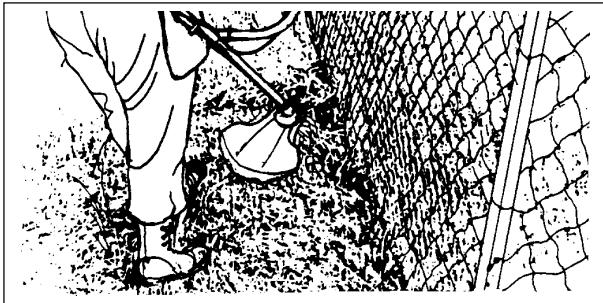

TRIMMING

The nylon line will allow you to trim along walls and fence lines. Always try to trim from right to left, walking behind the unit and parallel to the wall or fence, thus deflecting debris away from the operator.

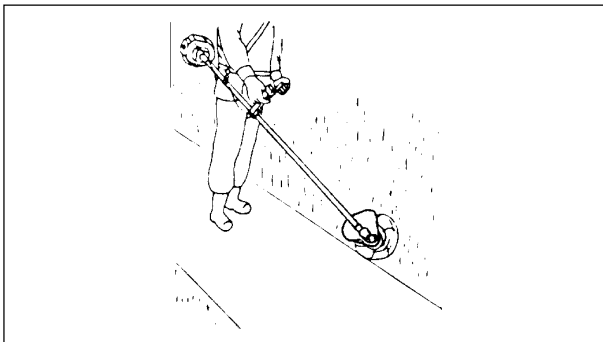

EDGING

1. The nylon line is intended only to cut grass and should not be used to cut a normal edging trench along stone or concrete driveway etc.
2. Tilt the unit vertically as illustrated and use only the line tip to remove unwanted growth.

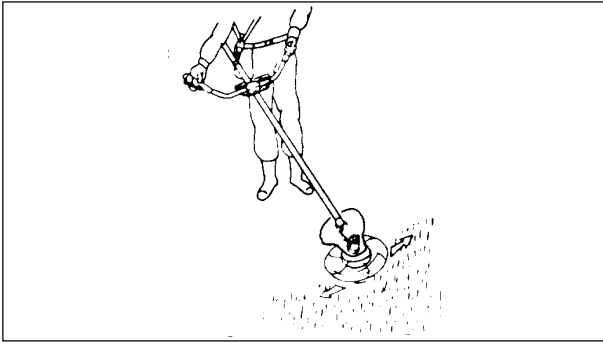

MOWING

- The nylon line will effectively mow large areas of heavy grass and/or weeds. Use the standard 12.5 to 15 cm (5 to 6 in) of line and operate at full throttle.
- When mowing cultivated areas such as lawns hold the cutter head parallel to the ground to avoid scalping.

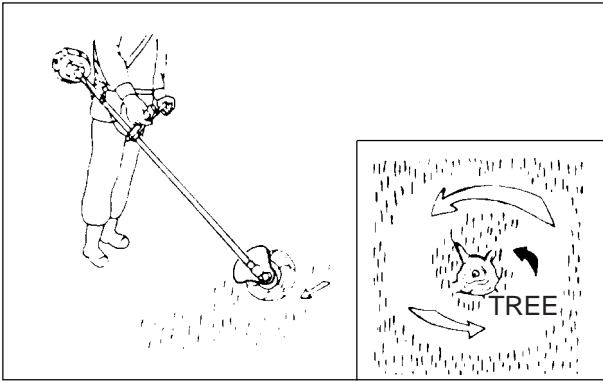

SCALPING

1. The cleaning of weeds and grass right down to the earth can be accomplished very easily with the nylon line.
2. Scalping around trees and bushes is particularly effective, but care should be exercised not to bruise the bark of young and sensitive growth.
3. In flower beds, always remember that the nylon line will cut in a complete circle to avoid cutting flowers instead of weeds.

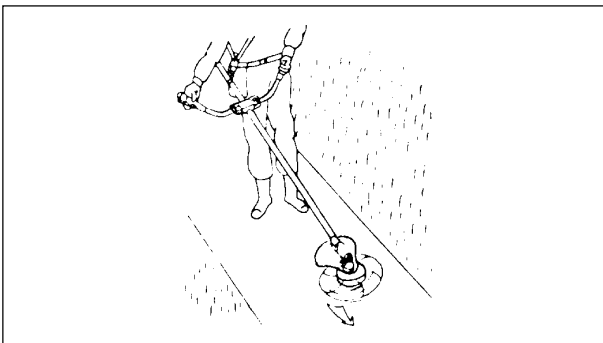

SWEEPING

Sweeping grass and other debris from a hard surface can be done very quickly.

STEEL BLADE OPERATIONS

Your ECHO Trimmer/Brushcutter is designed for fast, efficient weed and brush control in areas which are otherwise inaccessible to power equipment. Standard configuration includes a handle bar and nylon line head for light trimming and weed clearing. Two special steel blades are available as options and recommended for use in extended heavy weed and brush clearing operations :

1. Blade: weed and grass 8 tooth 20 cm (8 in) diameter
2. Blade: brush 80 tooth 25 cm (10 in) diameter

WARNING **DANGER**

1. **SERIOUS INJURY MAY RESULT FROM THE IMPROPER USE OF STEEL BLADES. READ AND COMPLY WITH SAFETY INSTRUCTIONS LISTED IN THIS MANUAL.**
2. **THE EIGHT TOOTH BLADE IS DESIGNED SPECIALLY TO CUT WEED AND GRASS. TO AVOID INJURY DUE TO KICKBACK OR BLADE FRACTURE, DO NOT USE THIS BLADE TO CUT BRUSH OR TREES.**
3. **ECHO INC. WILL NOT BE RESPONSIBLE FOR THE FAILURE OF CUTTING DEVICES WHICH HAVE NOT BEEN TESTED AND APPROVED BY ECHO FOR USE WITH THIS UNIT.**

WARNING  **DANGER**

SAFETY PRECAUTIONS

1. ALWAYS USE THE CORRECT BLADE FOR THE JOB AS RECOMMENDED.
2. BE CAREFUL NOT TO HIT ROCKS, STONES, TREE STUMPS OR ANY FOREIGN OBJECT WHICH MAY DAMAGE THE BLADE.
3. DO NOT CUT INTO THE GROUND TO AVOID DULLING THE BLADE.
4. ALWAYS STOP THE ENGINE AND EXAMINE THE BLADE AFTER STRIKING AN OBSTRUCTION. DO NOT OPERATE WITH A BLADE WHICH IS BLUNT, BENT, FRACTURED, OR DISCOLORED DUE TO OVERHEAT.
5. IN THE EVENT, THAT THE BLADE STRIKES AN OBSTRUCTION, OR IS OTHERWISE PREVENTED FROM ROTATING IN NORMAL OPERATION, THE CENTRIFUGAL CLUTCH WILL SLIP TO PREVENT ENGINE DAMAGE. IN THIS CASE, STOP THE ENGINE, FREE AND EXAMINE THE BLADE AND IF IN GOOD ORDER, RESUME OPERATION.
6. SHOULD THE BRUSHCUTTER BE OPERATED FOR AN EXTENDED PERIOD OF HIGH TEMPERATURES, THE GEAR BOX MAY BECOME VERY HOT. IF TOO HOT TO TOUCH, ALLOW THE UNIT TO COOL DOWN, CHECK THE LUBRICATION AS PER 'MAINTENANCE' AND CONTINUE TO OPERATE IF IN ORDER.
7. TO AVOID ENGINE DAMAGE, DO NOT RUN ON FULL THROTTLE WITHOUT LOAD.
8. DO NOT OPERATE THE BRUSHCUTTER WITHOUT THE HARNESS AND DEBRIS SHIELD CORRECTLY FITTED.
9. ALWAYS INSPECT THE WORK AREA AND REMOVE ANY FOREIGN OBJECTS.

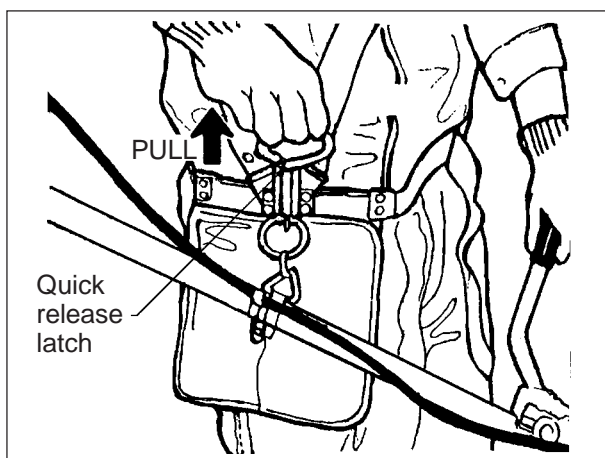

SHOULDER HARNESS

- Install the harness over the both shoulders and adjust shoulder straps so that the quick release latch rests low on the right hand side.
- Attach the trimmer/brushcutter to the harness by means of the quick release latch.
- Make some practice sweeps as with a scythe and readjust the harness as necessary for comfort and to maintain the cutter parallel to the ground.

WARNING  **DANGER**
IN CASE OF EMERGENCY, PULL THE QUICK RELEASE LATCH TO DISCONNECT THE TRIMMER FROM THE HARNESS.

SHIELD

When using a metal blade.
Use same as Nylon line.

INSTALLING THE BLADE

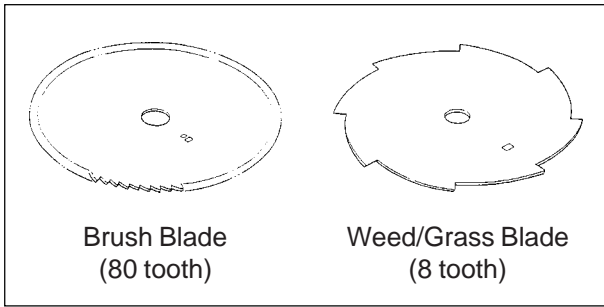

1. The installation of the 8 tooth weed/grass blade (option) and the 80 tooth brush is exactly the same.

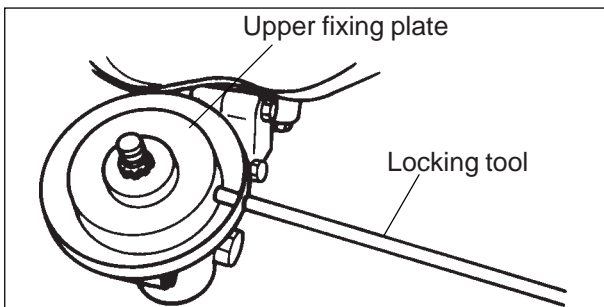

2. Rotate the drive shaft until the holes in the upper fixing plate and the gear box are aligned. Insert the locking tool.

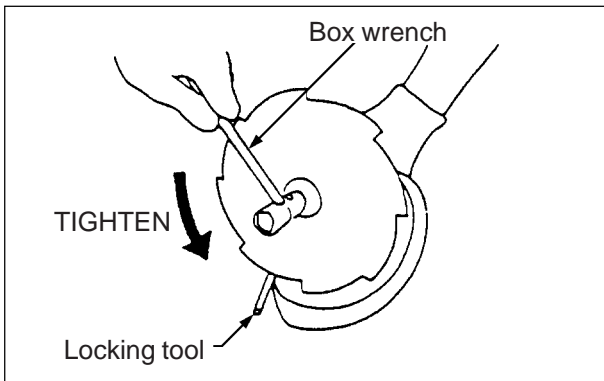

3. Remove the nylon line head, if fitted, by turning in a clockwise direction.
 4. Install the blade ensuring that it is centered correctly on the fixing plate.
 5. Fit the lower fixing plate and tighten the locking nut using the box wrench supplied in the tool kit.
 - Never fasten while applying your weight. Otherwise the thread of nut could be broken.

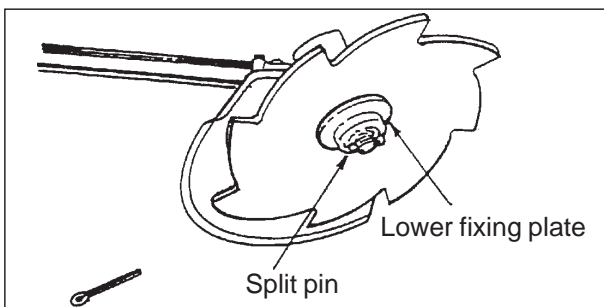

6. Fit a new split pin as supplied in the tool kit to secure the locking nut.

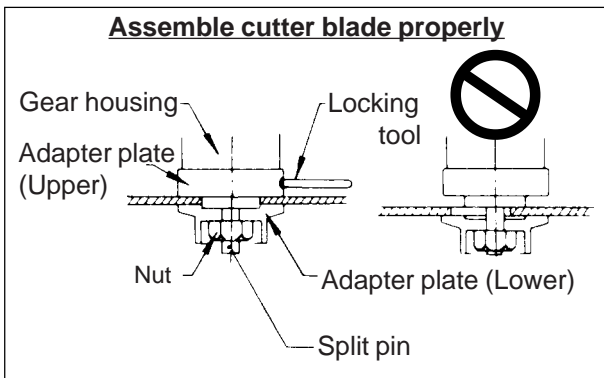

NOTE

- The drive shaft is fitted with left hand threads, therefore turn counterclockwise to tighten as illustrated.
- Always use a new split pin to secure the locking nut.
 Split pin 2 × 22 mm
 Part No. 898502-01130.

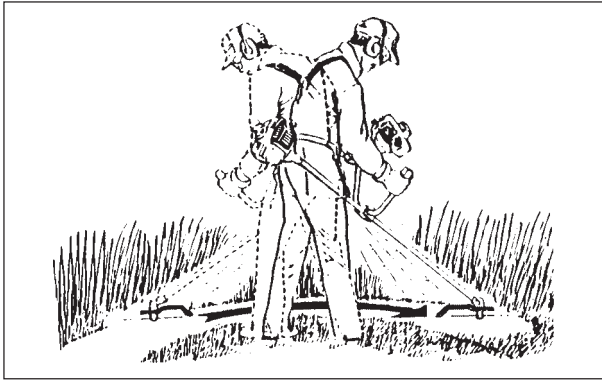

HEAVY WEED CUTTING

- Install the 8 tooth 20 cm (8 in) blade. (option)
- Observing all precautions as listed in this manual, start the engine and using full throttle, swing the blade in an arc as you move forward slowly. The cutter rotates counterclockwise and the debris will be pushed backwards so the work area will always be visible.

BRUSHCUTTING

- Install the 80 tooth blade.
- Proceed exactly as for weed and grass cutting.

SMALL TREES

- The unit will effectively cut small trees up to 7.5 cm (3 in) diameter using the 80 tooth 25 cm (10 in) diameter new blade.
- Before attempting to cut, ensure that the falling tree will fall away from you, and if necessary, tie a rope to the tree and have an assistant pull it in a safe direction.
- Do not attempt to “plunge cut”, i.e. using the brushcutter like an axe. It is not necessary and may cause serious damage to the brushcutter.
- Brace your feet firmly on the ground and cut with the left hand side of the blade.

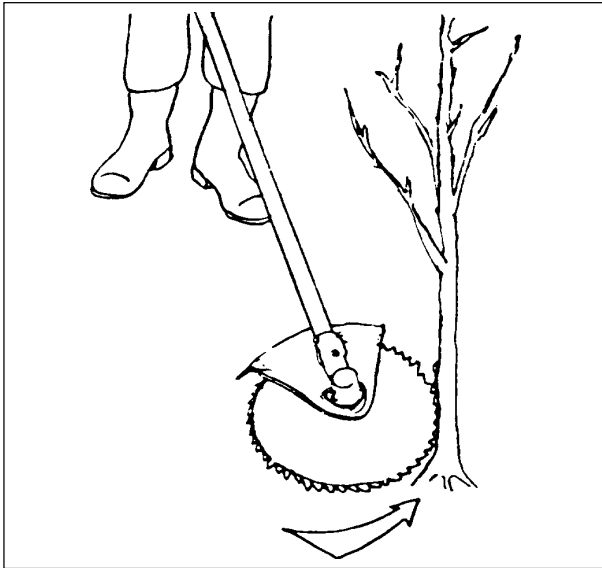

NOTE

1. Always cut on full throttle.
2. Never try cutting with a blunt blade.

MAINTENANCE AND CARE

- ALWAYS KEEP THE UNIT CLEAN -

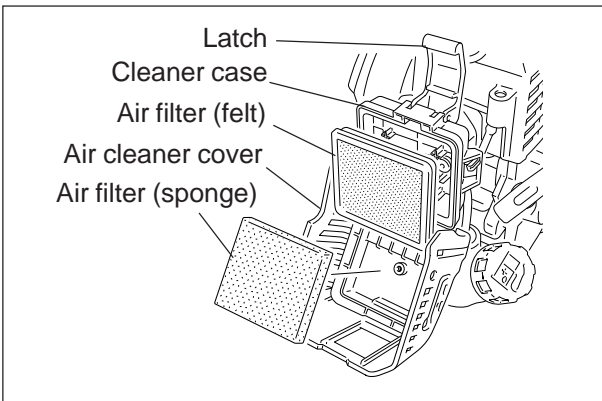

AIR FILTER

Clean before using the unit.

- Close choke. Disengage latch and remove air cleaner cover.
- Remove air filters (felt and sponge).
- Air filter (felt): Brush off dust lightly or clean with compressed air.
- Air filter (sponge): Brush off dust lightly or wash it in a non-flammable solvent if necessary.
- Soak air filter (sponge) into 2 stroke oil and squeeze it firmly not to allow remaining oil to trickle.
- Install the air filter (sponge) into air cleaner cover.
- Install the air filter (felt) into cleaner case.
- Install assembled air cleaner cover on cleaner case with air filter (felt) and engaged latch.

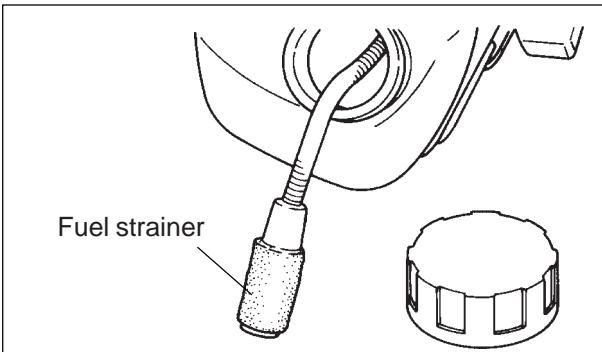

FUEL STRAINER

Check periodically.

- Do not allow dust to enter into fuel tank.
- Clogged strainer will cause difficulty in starting engine or abnormalities in engine performances.
- Pick up fuel strainer through fuel inlet port with a piece of steel wire or the like.
- When strainer is dirty, wash it in suitable cleaning fluid or replace it.

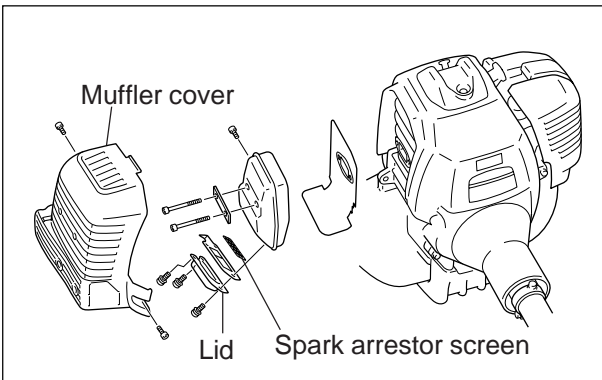

MUFFLER AND EXHAUST PORT (SAM)

- Clean as necessary.
- Carbon deposits in cylinder exhaust port and muffler will reduce engine output.
- Muffler can be removed by taking off muffler cover.
- Remove spark arrestor screen from muffler.
- Clean carbon deposits from screen and muffler components.
- Be careful not to scratch cylinder or piston when cleaning cylinder exhaust port.
Use non-ferrous plastic or wood.
- Replace spark arrestor screen if it is cracked, plugged or has holes burned through.
- Inspect gaskets, replace if damaged.
- Assemble components in reverse order.

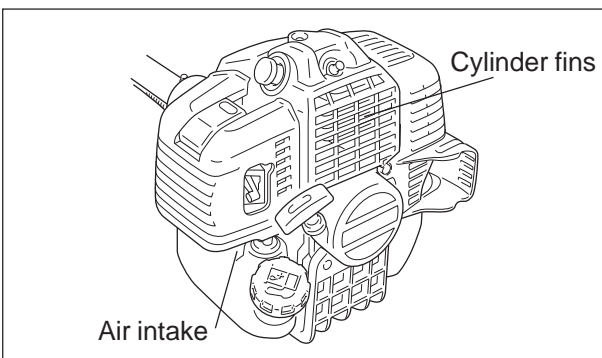

CYLINDER FINS

- Check periodically.
- Clogged fins will result in poor engine cooling.
- Remove dirt and dust from between fins to let cooling air pass easily.

CHECK FUEL SYSTEM

- Check before every use.
- After refuelling make sure fuel does not leak or exude from around fuel pipe, fuel grommet or fuel tank cap.
- In case of fuel leakage or exudation there is a danger of fire. Stop using the machine immediately and request your dealer to inspect or replace.

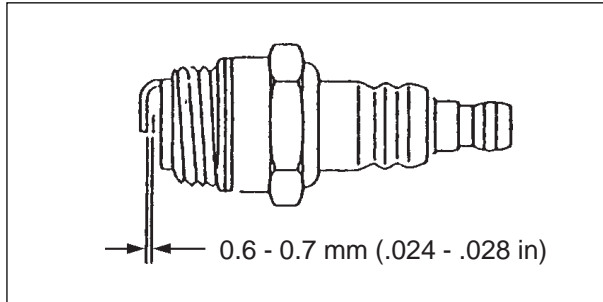

SPARK PLUG

- Check periodically.
- Standard spark plug gap is 0.6 to 0.7 mm (0.024 to 0.028 in).
- Replace if either electrode is worn or if the insulator is fouled by oil or other deposits.
- TORQUE = 15 to 17 N•m (130 to 145 in•lb)

NOTE

Do not over torque.

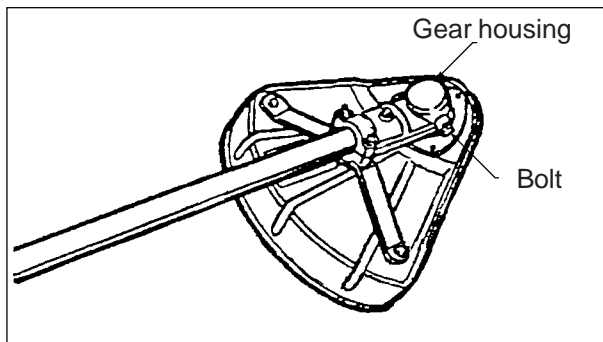

GEAR HOUSING

- Remove the bolt every 50 hours and check.
- Replenish as necessary, but do not overfill.
 - Good quality lithium multi grease is recommendable.

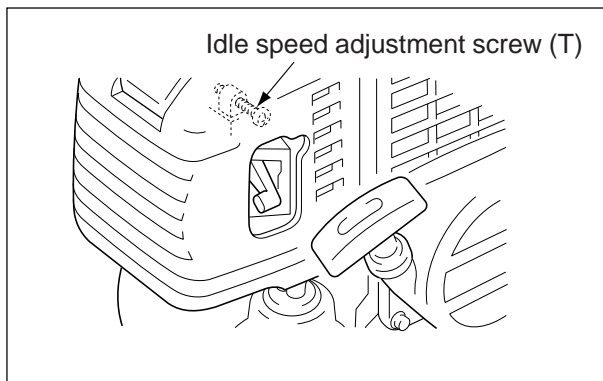

CARBURETOR ADJUSTMENT

Every unit is run at the factory and the carburetor is set in compliance with Emission Regulations, in addition.

1. Before adjusting carburetor clean or replace air filter and muffler, "Spark Arrestor Screen".
2. Make sure the cutting attachment such as hedge clipper blades or circular saw are properly adjusted. Trimmer line should be extended to cut-off knife.
3. Start engine and run several minutes to bring to operating temperature. Flash choke twice during warm-up to clear any air from the fuel system.
4. Idle Speed Adjustment

WARNING  **DANGER**
CUTTING ATTACHMENT MUST NOT TURN OR MOVE WHEN UNIT IS IDLING.

CAUTION

When starting, idling adjustment speed should be adjusted not to rotate the cutting attachment. Correct idle speed is adjusted 2,900 to 3,100 r/min. Or 1/4 turn CCW from the point the cutting attachment stops moving. When there is some trouble with the carburetor, refer to your dealer.

- Start engine, turn "idle" speed adjustment screw clockwise (CW) until the cutting attachment begins to turn, then turn screw out counterclockwise (CCW) until attachment stops turning. Turn screw out, CCW, an additional 1/4 turn.

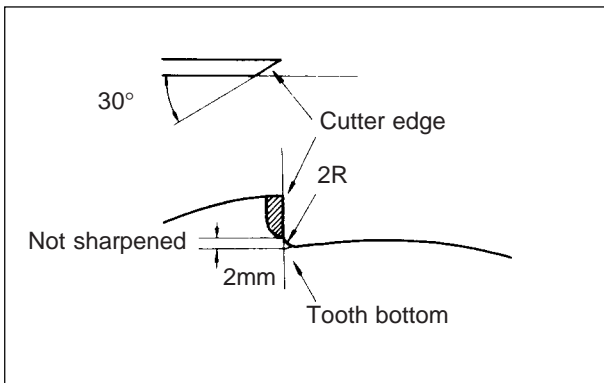

EIGHT CUTTER BLADE

- Use only the blade designated by the manufacturer for this model.
- When crack is noticed on the blade, never use it, but replace with a new one.
- Round the tooth bottom for 1- 2 mm radius in order to avoid the crack using a round file.
 - Rounded part is not to be sharpened.
 - Sharpen each cutter equally so as to retain the balance of the blade.
 - In sharpening the edge by use of a grinder, do not cool the cutter abruptly by immersing it in water.

MAGNETO

The unit is incorporated with a CDI (Capacitor Discharge Ignition) system, which does not require adjustment of ignition timing and the contact breaker point gap. Ensure wire connections and couplers assembling.

TROUBLE SHOOTING

Poor performance of the engine and/or trimming mechanism can normally be prevented by carefully following instructions.

Poor performances can easily be corrected even by a beginner.

When the engine does not function properly check the following three (3) points first.

- Is engine compression adequate?
- Is fuel system in good condition and is enough fuel being supplied?
- Is electrical system in good condition and is spark plug operating normally?

When there is serious trouble with the unit, do not try to repair it yourself but have your distributor or dealer do it for you. For detailed **TROUBLE SHOOTING** refer to tables 1 and 2. Locate the problem on the following charts and repair as necessary.

Table 1

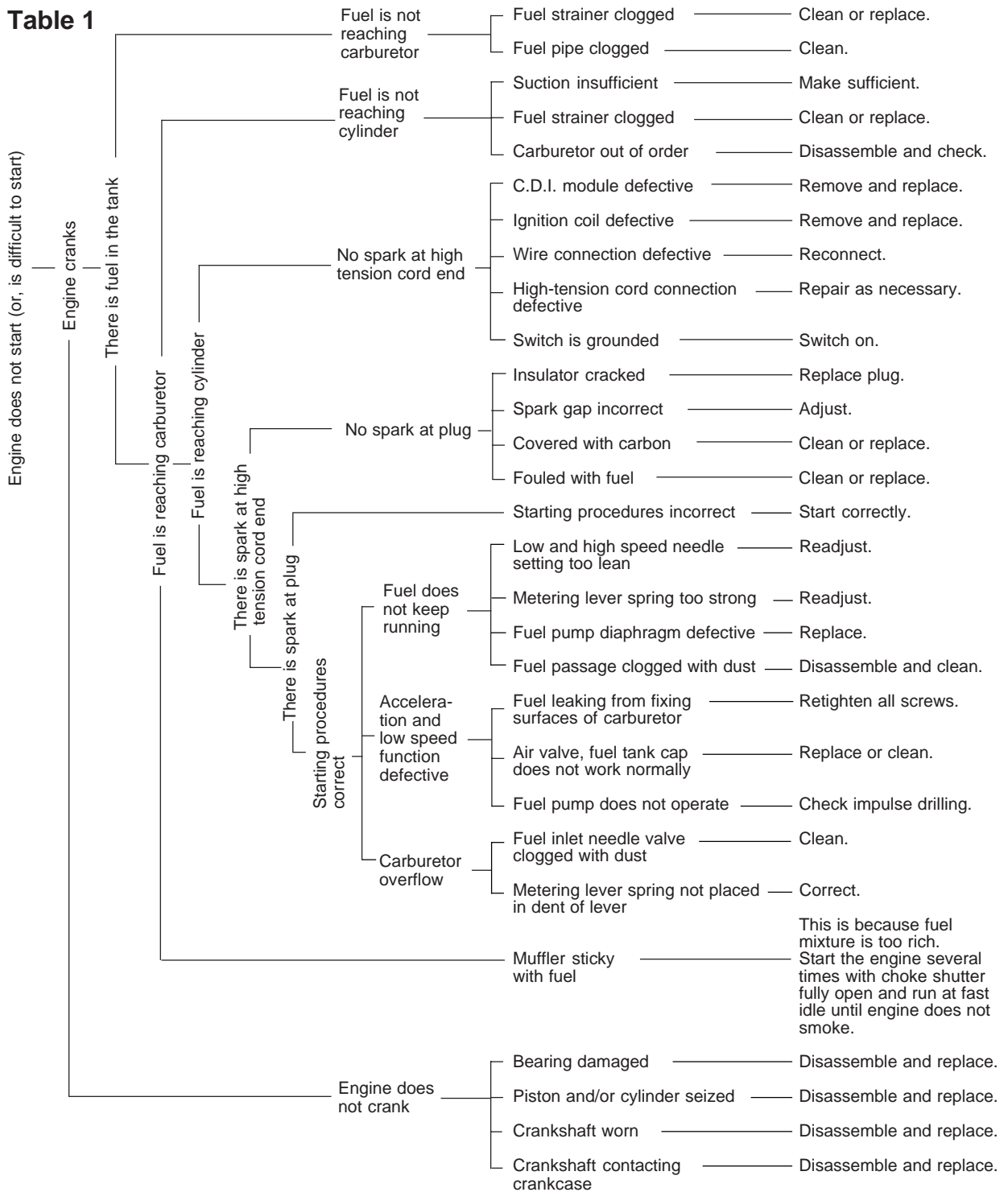
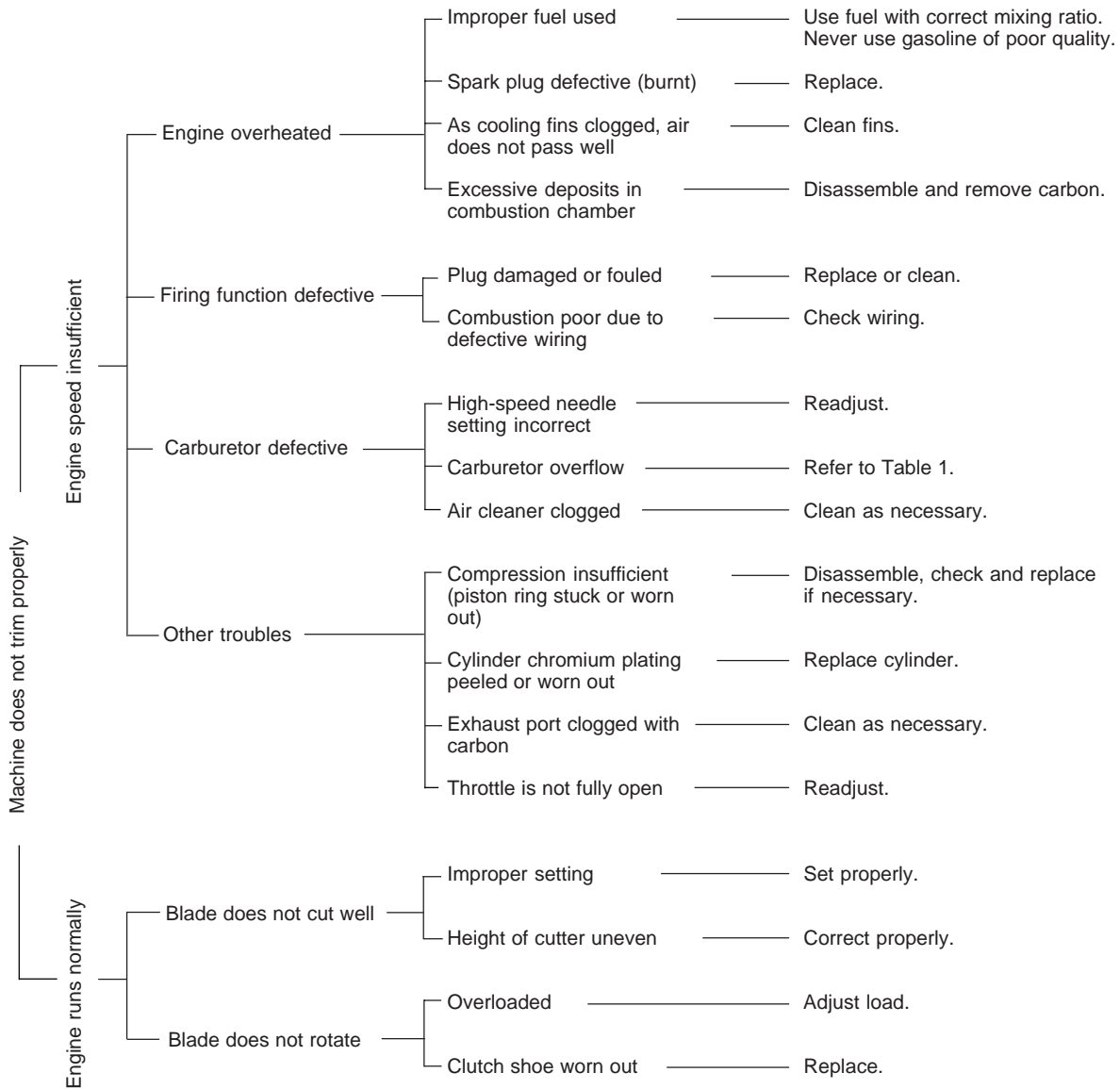

Table 2



WARNING  DANGER

FUEL VAPORS ARE EXTREMELY FLAMMABLE AND MAY CAUSE FIRE AND/OR EXPLOSION. NEVER TEST FOR IGNITION SPARK BY GROUNDING SPARK PLUG NEAR CYLINDER PLUG HOLE, OTHERWISE SERIOUS PERSONAL INJURY MAY RESULT.

LONG TERM STORAGE

- Inspect and adjust every part of the unit.
 - Completely clean every part, and repair, if necessary.
 - Apply thin coating of oil on metal parts to prevent rust.
 - Remove the cutter head, apply sufficient oil coating and wrap up in plastic.
- Drain fuel tank, pull starter handle slowly a few times to drain fuel from carburetor.
- Pour a small amount of clean motor oil into spark plug hole, pull starter handle and then crank the engine until TOP DEAD CENTER.
- Store in a dry area, free from dust.