



POWER BLOWER

Operator's Manual

MODEL	PB-46HT Serial Number 007116 & Up	TYPE 1E
	PB-46LN Serial Number 001051 & Up	TYPE 1E
	PB-60HT Serial Number 001001 & Up	TYPE 1E

 **WARNING** 

The engine exhaust from this product contains chemicals known to the State of California to cause cancer, birth defects or other reproductive harm.

WARNING  **DANGER**

Read rules for safe operation and all instructions carefully. ECHO provides this Operator's Manual which must be read and understood for proper and safe operation.

INTRODUCTION

Welcome to the ECHO family. This ECHO product was designed and manufactured to provide long life and on-the-job-dependability. Read and understand this manual. You will find it easy to use and full of helpful operating tips and SAFETY messages.

WARNING **DANGER**

Read rules for safe operation and instructions carefully. ECHO provides this Operator's Manual which must be read and understood for proper and safe operation.

THE OPERATOR'S MANUAL --

contains specifications and information for operation, starting, stopping, maintenance, storage and assembly specific to this product.

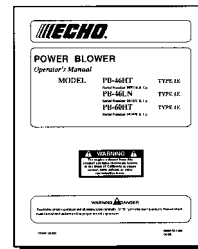

TABLE OF CONTENTS

Introduction	2	- Stopping Engine	15
- The Operator's Manual	2	- Operating Blower	15
Manual Safety Symbols and Important Information ..	3	Maintenance	17
Safety	3	- Skill Levels	17
- General Description	3	- Maintenance Intervals	17
- Decals	4	- Air filter	18
- International Symbols	4	- Fuel Filter	18
- Equipment	5	- Spark Plug	19
- Fuel	5	- Cooling System	19
- Personal Condition and Safety Equipment	6	- Exhaust System	20
- Safe Operation	7	- Carburetor Adjustment	21
- Extended Operation/Extreme Conditions	8	Troubleshooting	22
Description	9	Storage	23
- Emission Control	9	Servicing Information	24
- Contents	9	- Parts	24
Specifications	11	- Service	24
Assembly	12	- Customer Assistance	24
- Install Blower Pipes	12	- Warranty Card	24
- Install Stick Handle	12	- Additional or Replacement Manuals	24
Pre-Operation	13	- Manual Ordering Instructions	24
- Fuel	13		
Operation	14		
- Starting Cold Engine	14		
- Starting Warm Engine	15		

Specifications, descriptions and illustrative material in this literature are as accurate as known at the time of publication, but are subject to change without notice. Illustrations may include optional equipment and accessories, and may not include all standard equipment.

MANUAL SAFETY SYMBOLS AND IMPORTANT INFORMATION

Throughout this manual and on the product itself, you will find safety alerts and helpful, information messages preceded by symbols or key words. The following is an explanation of those symbols and key words and what they mean to you.



This symbol accompanied by the words **WARNING** and **DANGER** calls attention to an act or condition that can lead to serious personal injury to operator and bystanders.



The circle with the slash symbol means whatever is shown within the circle is prohibited.



IMPORTANT The enclosed message provides information necessary for the protection of the unit.

NOTE This enclosed message provides tips for use, care and maintenance of the unit.

SAFETY

GENERAL DESCRIPTION

IMPORTANT

See Description and Specification sections and Decals in this section for full description and illustration of power head, and blower assembly.

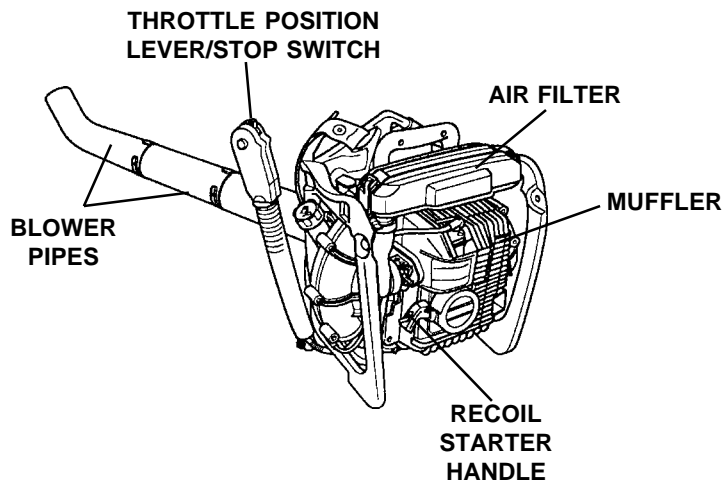

DECALS

Locate these safety decals on your unit. The complete unit illustration, found in the "DESCRIPTION" section, will help you locate them. Make sure the decals are legible and that you understand and follow the instructions on them. If a decal cannot be read, a new one can be ordered from your ECHO dealer. See PARTS ORDERING instructions for specific information.

HOT DECAL

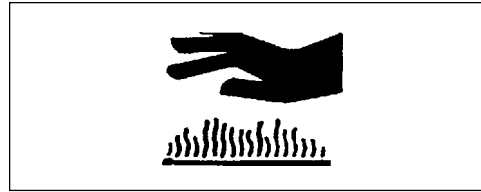

GENERAL WARNING DECAL

**-WARNING-
-DANGER-** 

Read and follow all safety precautions in the operator's manual. Operators, helpers & bystanders can be severely injured by blown objects and must wear specified ANSI Z87.1 eye protection. Always wear hearing protection when operating.

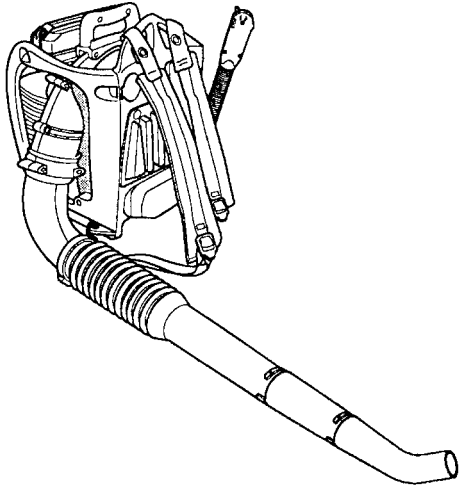

SPANISH DECAL

ADVERTENCIA

PELIGRO

Esta unidad puede ser peligrosa y producir lesiones personales graves si no se usa en forma adecuada. Para reducir el riesgo de lesionarse, los operadores, los ayudantes y los espectadores deben leer y comprender el Manual Del Operador que se entrega escrito en español.

ENGLISH TRANSLATION







WARNING

DANGER



This unit can be dangerous and cause serious injury if improperly used. To reduce injury risk to operator, helpers and bystanders, read and understand the Operator's Manual, which is provided in Spanish.

PB-46HT
MAXIMUM SOUND LEVEL **70dB(A)**
measured at 15 m (50 ft.) per ANSI B175.2-1996 •

PB-46LN
MAXIMUM SOUND LEVEL **65dB(A)**
measured at 15 m (50 ft.) per ANSI B175.2-1996 •

INTERNATIONAL SYMBOLS

Symbol form/shape	Symbol description/application	Symbol form/shape	Symbol description/application
	Read and understand Operator's Manual.		Fuel and oil mixture
	Wear eyes, ears and head protection		Finger Severing
	Hot Surface		Emergency stop

Symbol form/shape	Symbol description/application	Symbol form/shape	Symbol description/application
	Primer bulb	H	Carburetor adjustment - High speed mixture
Ignition 	Ignition ON/OFF	T	Carburetor adjustment - Idle speed
		L	Carburetor adjustment - Low speed mixture

EQUIPMENT

Before operation a complete check of the unit must be performed:

- Check unit for loose/missing nuts, bolts and screws. Tighten and/or replace as needed.
- Inspect fuel lines, tank and area around carburetor for fuel leaks. **DO NOT** operate unit if leaks are found.

Spark Arrestor Muffler

- The spark arrestor muffler controls the exhaust noise and prevents hot, glowing particles of carbon from leaving the muffler. Make sure the spark arrestor screen is in good repair and properly seated in the muffler. (Refer to Exhaust System Maintenance pg. 19.)

Parts

- Do not use blower if any part is missing or damaged.
- Have repairs done only by an authorized ECHO Service dealer.
- Do not use any attachment, accessory or replacement part unless it is recommended in this Operator's Manual.

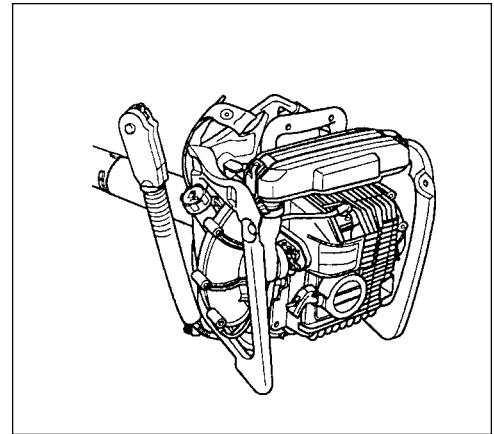

FUEL

WARNING  DANGER

Fuel is **VERY** flammable. Use extreme care when mixing, storing or handling or serious personal injury may result.

- Use an approved fuel container.
- **DO NOT** smoke near fuel.
- **DO NOT** allow flames or sparks near fuel.
- Fuel tanks/cans may be under pressure. Always loosen fuel caps slowly allowing pressure to equalize.
- **NEVER** refuel a unit when the engine is **HOT!**
- **NEVER** refuel a unit with the engine running.
- **DO NOT** fill fuel tanks indoors. **ALWAYS** fill fuel tanks outdoors over bare ground.
- Securely tighten fuel cap after refueling.
- Inspect for fuel leakage. If fuel leakage is found, do not start or operate unit until leakage is repaired.



After Refueling:

- Wipe any spilled fuel from the unit.
- Move at least 3 M (10 ft.) from refueling location before starting.

After use:

- **DO NOT** store a unit with fuel in its tank. Leaks can occur. Return unused fuel to an approved fuel storage container.

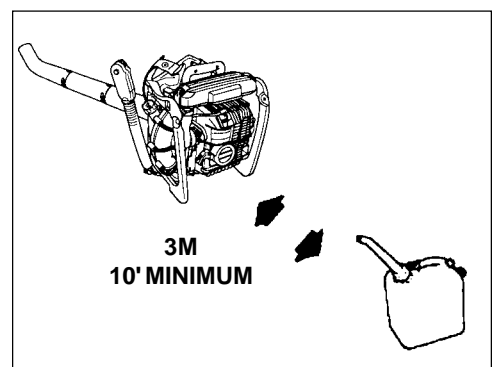

PERSONAL CONDITION AND SAFETY EQUIPMENT

WARNING DANGER

Power Blower users risk injury to themselves and others if the power blower is used improperly and or safety precautions are not followed. Proper clothing and safety gear must be worn when operating a blower.

Physical Condition --

Your judgment and physical dexterity may not be good:

- if you are tired or sick,
- if you are taking medication,
- if you have taken alcohol or drugs.

Operate unit only if you are physically and mentally well.



Eye Protection --

Wear eye protection that meets ANSI Z87.1 or CE requirements whenever you operate the blower.



Hand Protection --

Wear no-slip, heavy duty work gloves to improve your grip on the blower handle. Gloves also reduce the transmission of machine vibration to your hands.

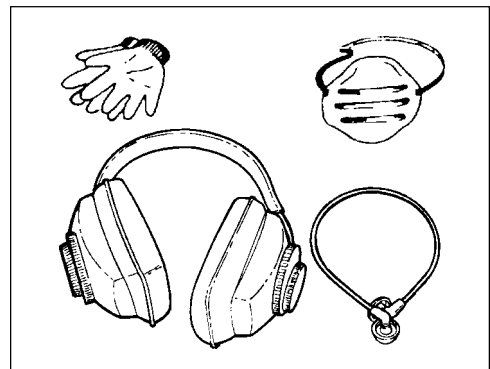

Breathing Protection --

Wear a face mask to protect against dust.

Hearing Protection --

ECHO recommends wearing hearing protection whenever unit is used.

Proper Clothing --

Wear snug fitting, durable clothing;

- Pants should have long legs, shirts with long sleeves.
- DO NOT WEAR SHORTS,
- DO NOT WEAR TIES, SCARVES, JEWELRY.

Wear sturdy work shoes with nonskid soles;

- DO NOT WEAR OPEN TOED SHOES,
- DO NOT OPERATE UNIT BAREFOOTED.

Keep long hair away from engine and blower intake. Retain hair with cap or net.

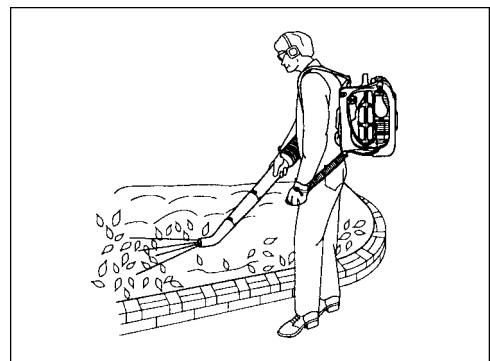

Hot Humid Weather --

Heavy protective clothing can increase operator fatigue which may lead to heat stroke. Schedule heavy work for early morning or late afternoon hours when temperatures are cooler.

SAFE OPERATION

Determine Operation Area --

- Review area to be cleared. Look for potential hazards such as stones or metal objects.
- Spectators and fellow workers must be warned, and children and animals prevented from coming nearer than 15M (50 ft.) while the blower is in use.
- Do not operate this product indoors or in inadequately ventilated areas..
- Take wind conditions into account: avoid open doors and windows.
- Provide all operators of this equipment with the Operator's Manual and instructions for safe operation.
- Do not point blower at people or animals.

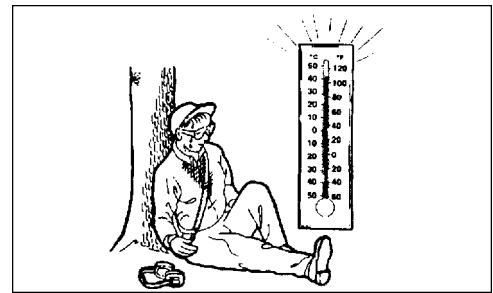

Use Proper Clothing & Equipment

- Before starting the unit, equip yourself and any other person working within the 15M (50 ft.) Safety Zone with the required Protective Equipment and clothing.
- Keep long hair away from engine and blower intake. Retain hair with cap or net.
- Start unit on ground with throttle at idle. Check that blower pipe is not blocked by the ground or by any objects.

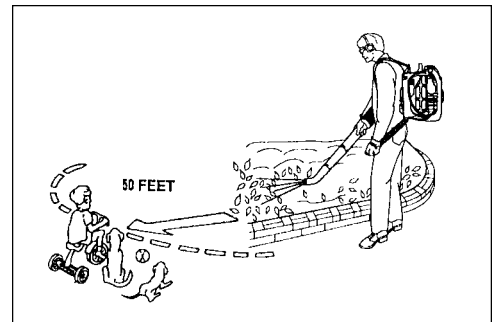

Keep A Firm Grip

- Hold handle with fingers together encircling the handle.



Keep A Solid Stance

- Maintain footing and balance at all times. Do not stand on slippery, uneven or unstable surfaces. Do not work in odd positions or on ladders.
- Do not perform Maintenance or Assembly procedures with engine running.

Noise Control

- Follow local noise regulations on sound levels and hours of operations. Use only during appropriate hours.
- Never use a higher speed setting then necessary to perform a task. The higher the engine speed the louder the blower noise.
- Be a good neighbor.

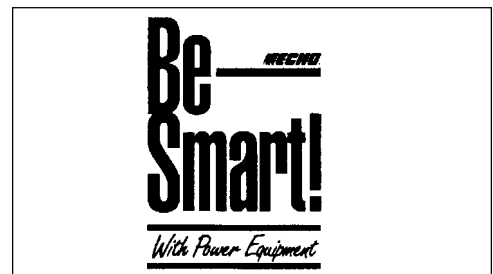

Avoid Hot Surfaces

- During operation, the exhaust area may become very hot, too hot to touch. Avoid contact during and immediately after operation.

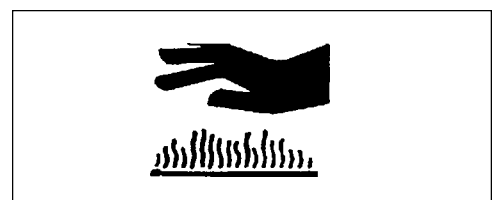

EXTENDED OPERATION/EXTREME CONDITIONS

Vibration and Cold --

It is believed that a condition called Raynaud's Phenomenon, which affects the fingers of certain individuals may be brought about by exposure to vibration and cold. Exposure to vibration and cold may cause tingling and burning sensations followed by loss of color and numbness in the fingers. The following precautions are strongly recommended because the minimum exposure which might trigger the ailment is unknown.

- Keep your body warm, especially the head, neck, feet, ankles, hands and wrists.
- Maintain good blood circulation by performing vigorous arm exercises during frequent work breaks and also by not smoking.
- Limit the hours of operation. Try to fill each day with jobs where operating the blower or other hand-held power equipment is not required.
- If you experience discomfort, redness and swelling of the fingers followed by whitening and loss of feeling, consult your physician before further exposing yourself to cold and vibration.

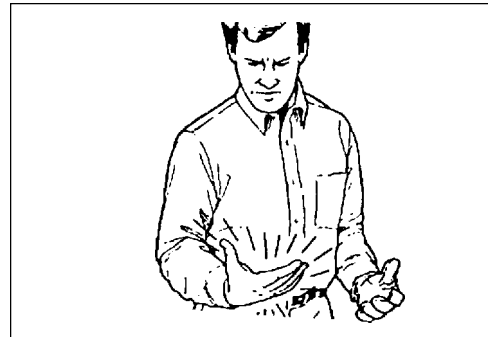
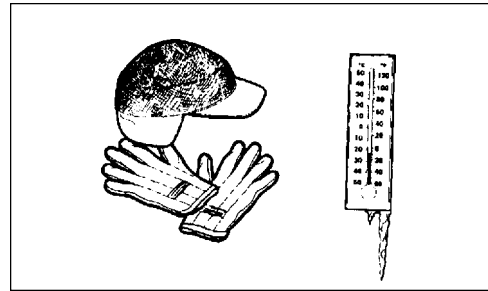

Repetitive Stress Injuries --

It is believed that overusing the muscles and tendons of the fingers, hands, arms and shoulders may cause soreness, swelling, numbness, weakness and extreme pain in those areas. Certain repetitive hand activities may put you at a high risk for developing a Repetitive Stress Injury (RSI). An extreme RSI condition is Carpal Tunnel Syndrome (CTS), which could occur when your wrist swells and squeezes a vital nerve that runs through the area. Some believe that prolonged exposure to vibration may contribute to CTS. CTS can cause severe pain for months or even years. To reduce the risk of RSI/CTS, do the following:

- Avoid using your wrist in a bent, extended or twisted position. Instead try to maintain a straight wrist position. Also, when grasping, use your whole hand, not just the thumb and index finger.
- Take periodic breaks to minimize repetition and rest your hands.
- Reduce the speed & force in which you do the repetitive movement.
- Do exercises to strengthen the hand and arm muscles.
- Immediately stop using all power equipment and consult a doctor if you feel tingling, numbness or pain in the fingers, hands, wrists or arms. The sooner RSI/CTS is diagnosed, the more likely permanent nerve and muscle damage can be prevented.

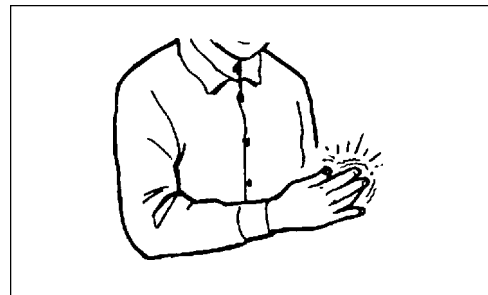
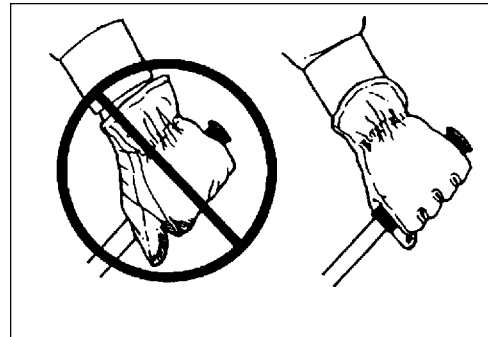

DESCRIPTION

EMISSION CONTROL

The emission control system for this engine is EM (Engine Modification).

An Emission Control Label is located on the engine. (This is an EXAMPLE ONLY, information on label varies by engine FAMILY).

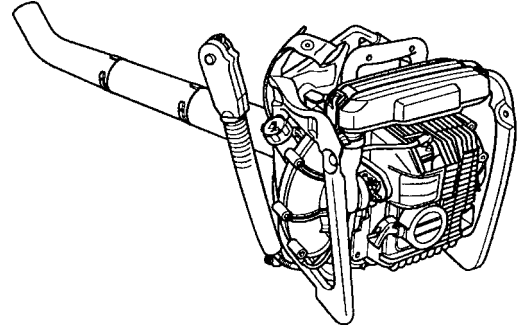

IMPORTANT ENGINE INFORMATION

ENGINE FAMILY: SEH044U124RA

DISPLACEMENT: 44cc

THIS ENGINE MEETS U.S. EPA PHI AND 1995-1999 CALIFORNIA EMISSION REGULATIONS FOR ULGE ENGINES. REFER TO OWNER'S MANUAL FOR MAINTENANCE SPECIFICATIONS AND ADJUSTMENTS.



ECHO CORP. * * *

CONTENTS

- 1-Power Head
- 1-Blower Pipe Assembly
- 1-Plastic Bag
 - 1- Operator's Manual
 - 1- Warranty Registration Card
 - 1- ECHO Emissions and Warranty Statement
- 2- Clamps w/screws
- 1- Stick Handle Assembly
- 1-Bottle ECHO 2-Stroke Oil Mix

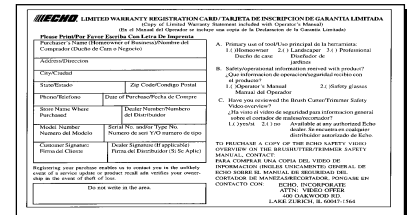
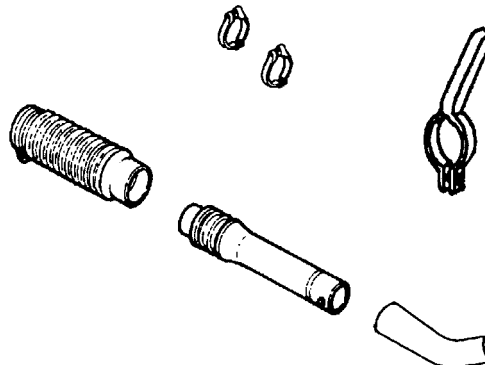
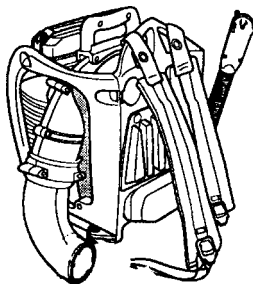
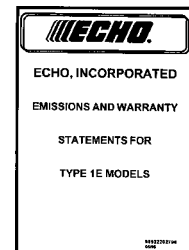
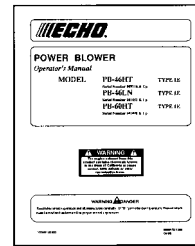

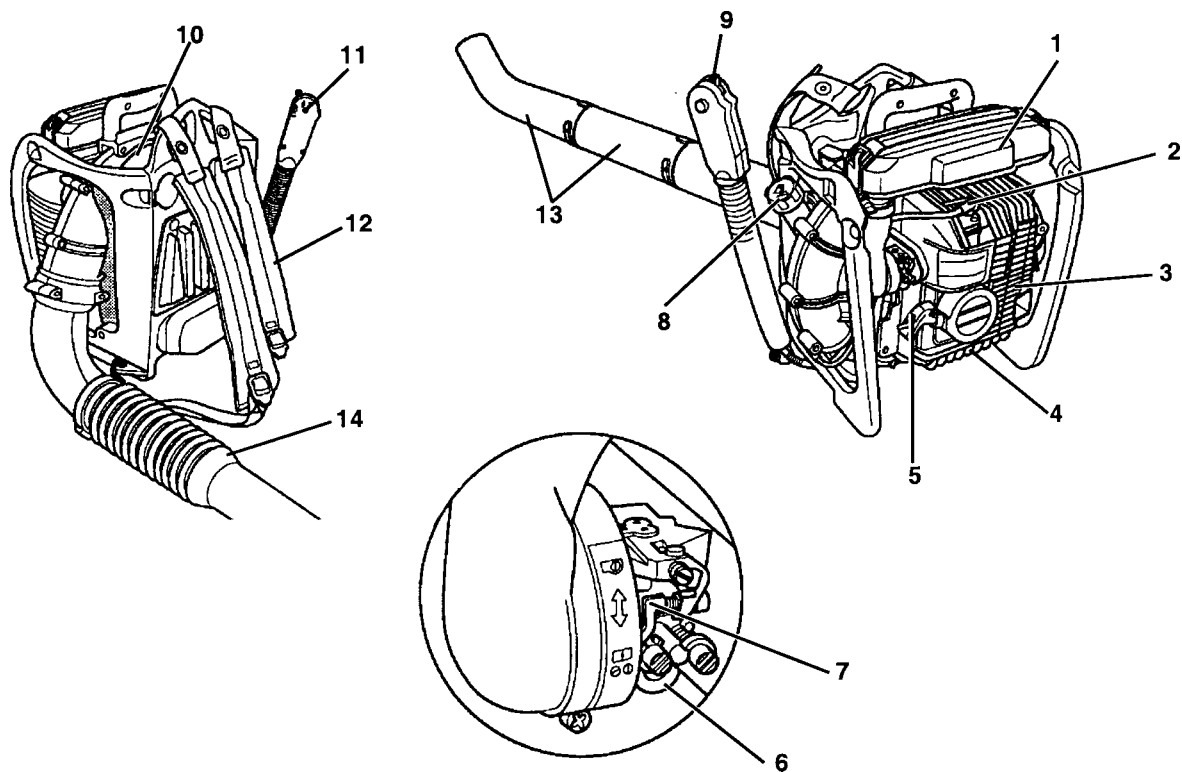

1. **AIR CLEANER** - Contains replaceable air filter element.
2. **SPARK PLUG** - Provides spark to ignite fuel mixture. Spark plug is located under the cover on LN models.
3. **MUFFLER/SPARK ARRESTOR** - The spark arrestor muffler controls the exhaust noise while the spark arrestor prevents hot, glowing particles of carbon from leaving the muffler where they could possibly start a fire.
4. **SERIAL NUMBER LABEL** - Located on underside of unit below starter housing. Lists model number and serial number of unit. If unit is emission certified, label identifies unit as TYPE 1E.
5. **RECOIL STARTER HANDLE** - Pull recoil handle slowly until starter engages, then quickly and firmly. When engine starts, return handle slowly. **DO NOT** let handle snap back or damage to unit will occur.
6. **PRIMER BULB** - Pumping primer bulb before starting engine draws fresh fuel from the fuel tank priming the carburetor for starting. Pump the bulb 10 times until fuel is visible in clear fuel return line.
7. **CHOKE** - Move lever **DOWN** to close choke (starting position) and for emergency stopping. Move **UP** to open choke (run position).
8. **FUEL TANK CAP** - Covers and seals fuel tank.
9. **THROTTLE POSITION LEVER/STOP SWITCH** - Combination stop switch and variable speed throttle lever. When the lever is moved all the way forward the blower is at Wide Open Throttle (W.O.T.). When the lever is moved rearward to detent, the blower is at idle. When the lever is moved rearward past the idle detent the blower will stop.
10. **SAFETY DECAL** - Lists important safety precautions.
11. **HANDLE** - Rotates downward for throttle control access. Spring loaded for flexible operation.
12. **SHOULDER HARNESS** - Used to support unit on operator's back. The straps are adjustable.
13. **BLOWER PIPES** - Twist lock design.
14. **FLEXIBLE PIPE** - Allows for full range of movement.

SPECIFICATIONS

Dimensions	Length	320 mm (12.6 in.)	
	Width	460 mm (18.1 in.)	
	Height	440 mm (17.3 in.)	
	Weight	PB-46HT/LN TYPE1E (HT) 10.2 kg (22.4 lb.) (LN) 11kg (24.5 lb.)	PB-60HT TYPE1E HT 10.1 kg (22.2 lb.)
Engine	Type	Air-cooled, two-stroke, single cylinder gasoline engine	
	Bore	PB-46HT/LN TYPE1E 40.0 mm (1.574 in.)	PB-60HT TYPE1E 46.0 mm (2.811 in.)
	Stroke	35.0 mm (1.378 in.)	35.0 mm (1.378 in.)
	Displacement	44cc (2.69 cu. in.)	58.2cc (3.55 cu. in.)
Exhaust System		*Spark arrestor muffler	
Carburetor		ZAMA diaphragm type w/purge	
	Idle Speed	2600 to 2800 RPM	
	Maxium Speed	6400 to 6600 RPM*	7400 to 7600 RPM*
Ignition System		Flywheel magneto, CDI System	
	Spark Plug	NGK BPM-7Y 0.65 mm (0.026 in.)	
Starter System		Recoil starter	
Fuel System	Fuel	Mixed (gasoline and oil)	
	Fuel/Oil Ratio	50:1	
	Gasoline	89 octane unleaded. Do not use fuel containing methyl alcohol, more than 10% ethyl alcohol or 15% MTBE.	
	Oil	50:1 ECHO High Performance 2-Stroke engine oil	
	Fuel Tank Capacity	1.9 lit. (64.3 U.S. fl. oz.)	
Maximum Air Speed (measured at pipe end)		PB-46HT/LN TYPE1E 170 MPH (miles/hour)	PB-60HT TYPE1E 195 MPH (miles/hour)
	Average Air Volume (measured at pipe end)	365 CFM (cubic feet/minute)	405 CFM (cubic feet/minute)
Maximum Air Volume (measured at housing)		740 CFM (cubic feet/minute)	840 CFM (cubic feet/minute)

* Certain internal combustion engines operated in forest, brush and/or grass-covered areas in Washington, Oregon, Idaho, California, Minnesota, New Jersey and Maine must be equipped with a spark arrestor. This requirement also applies to all U.S. Forest Service lands. In some of these areas, the spark arrestor system must be certified per USDA Forest Service regulations SAEJ335. Check with your local or state authorities for specific regulations in your area. Failure to follow these requirements is a violation of the law.

Important: This spark ignition system complies with Canadian ICES-002

ASSEMBLY

WARNING DANGER

Never perform maintenance or assembly procedures with engine running or serious personal injury may result.

INSTALL BLOWER PIPES

1. Assemble clamp (A) onto both ends of flexible pipe (B).
2. Assemble straight pipe with swivel (C) into flexible pipe (B) and tighten clamp (A).
3. Assemble flexible pipe (B) to elbow (D) on blower and tighten clamp (A).
4. Assemble straight pipe (E) to pipe with swivel (C), turning straight pipe clockwise to lock in place.
5. Assemble curved pipe (F) to straight pipe (E) turning curved pipe clockwise to lock in place.

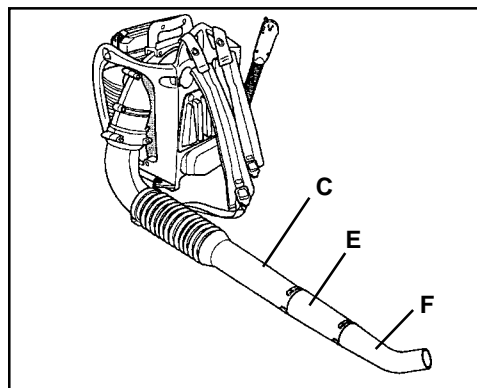
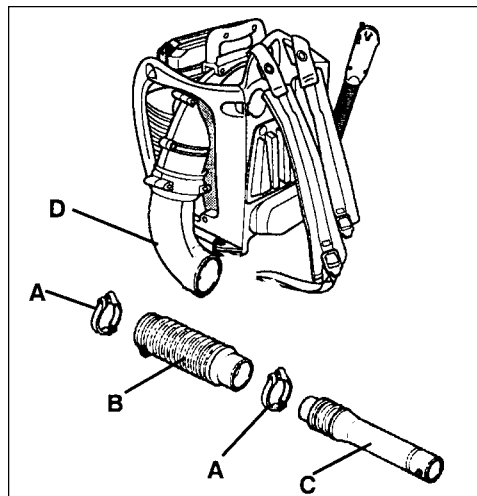

INSTALL STICK HANDLE

1. Remove blower pipe from swivel tube (C).
2. Loosen wing nut (G) completely and expand open stick handle clamp (H).
3. Align notches (J) in handle clamp with pipe pegs (K). Handle should be angled away from operator.
4. Slide handle onto swivel tube (C).
5. Position handle for comfortable operation and tighten wing nut (G).
6. Install blower pipe to swivel tube.

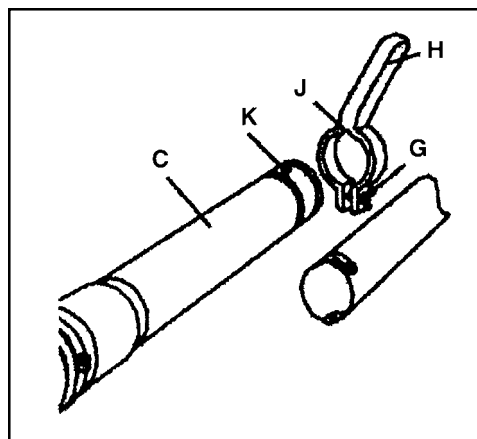

PRE-OPERATION

FUEL

Fuel Requirements

Gasoline - Use 89 Octane [$\frac{R+M}{2}$] gasoline or gasohol known to be good quality. Gasohol may contain up to 10% Ethyl (grain) alcohol or 15% MTBE (methyl tertiary-butyl ether). Gasohol containing methyl (wood) alcohol is **NOT** approved.

Two Stroke Oil - A two-stroke engine oil meeting ISO-L-EGD Standard (ISO/CD 13738), must be used. Echo brand Premium 50:1 oil meets this standard. Engine problems due to inadequate lubrication caused by failure to use an ISO-L-EGD approved oil, such as Echo Premium 50:1 Two-stroke Oil, will void the two-stroke engine warranty. (Emission related parts only are covered for two years, regardless of two-stroke oil used, per the statement listed in the EPA Phase I/California Emission Defect Warranty Explanation.)

Mixing - Follow directions on the oil container.

Handling Fuel

WARNING DANGER

Fuel is **VERY** flammable. Use extreme care when mixing, storing or handling or serious personal injury may result.

- Use an approved fuel container.
- DO NOT smoke near fuel.
- DO NOT allow flames or sparks near fuel.
- Fuel tanks/cans may be under pressure. Always loosen fuel caps slowly allowing pressure to equalize.
- NEVER refuel a unit when the engine is HOT!
- NEVER refuel a unit with the engine running.
- DO NOT fill fuel tanks indoors. ALWAYS fill fuel tanks outdoors over bare ground.
- Securely tighten fuel cap after refueling.
- Inspect for fuel leakage. If fuel leakage is found, do not start or operate unit until leakage is repaired.

After Refueling -

- Wipe any spilled fuel from the unit.
- Move at least 3M. (10 ft.) from refueling location before starting.

After use -

- DO NOT store a unit with fuel in its tank. Leaks can occur. Return unused fuel to an approved fuel storage container.

Storage -

Fuel storage laws vary by locality. Contact your local government for the laws affecting your area. As a precaution, store fuel in an approved, air tight container. Store in a well ventilated, unoccupied building, away from sparks and flames. Do not store fuel longer than 30 days.

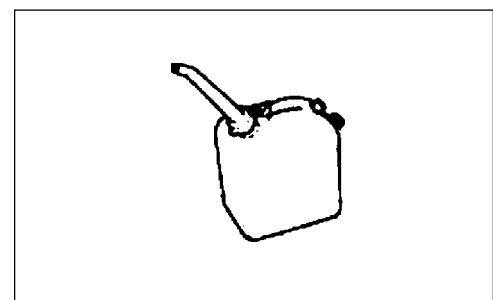
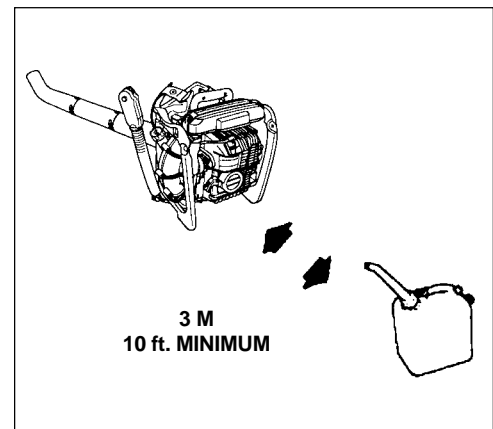
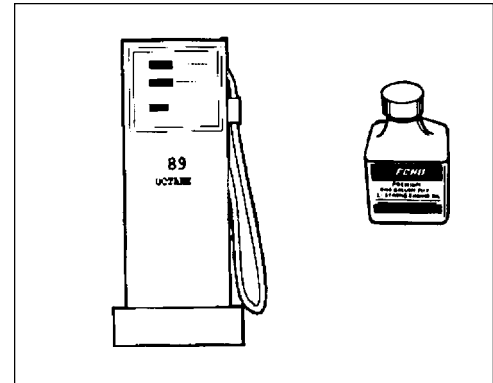

IMPORTANT

Stored fuel ages. Do not mix more fuel than you expect to use in thirty (30) days, ninety (90) days when a fuel stabilizer is added.

Stored two-stroke fuel may separate. ALWAYS shake fuel container thoroughly before each use.

S	M	T	W	T	F	S
1	2	3	4	5	6	7
8	9	10	11	12	13	14
15	16	17	18	19	20	21
22	23	24	25	26	27	28
29	30	31				

OPERATION

- Provide all operators of this equipment with the Operator's Manual and instructions for safe operation.
- Check unit for loose nuts, bolts and screws daily.
- Recoil starter: Use short pulls - only 1/2-2/3 of rope length for starting. Do not allow the rope to snap back in. Always hold the unit firmly.
- Rotate spring loaded throttle handle downward to a comfortable operating position.

STARTING COLD ENGINE

1. Move throttle lever (A) to START/IDLE DETENT position.
2. Close Choke - Cold Start.
Move choke (B) to "Cold Start" Position.
3. Primer Bulb-Prime.
Pump primer bulb (C) 10 times. Fuel will be visible and flow freely in the clear fuel tank return line.
4. Open choke (C) and if necessary, restart engine.

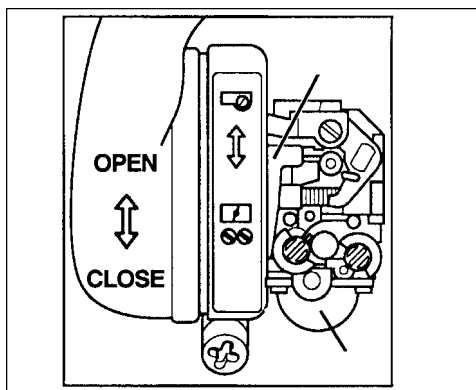
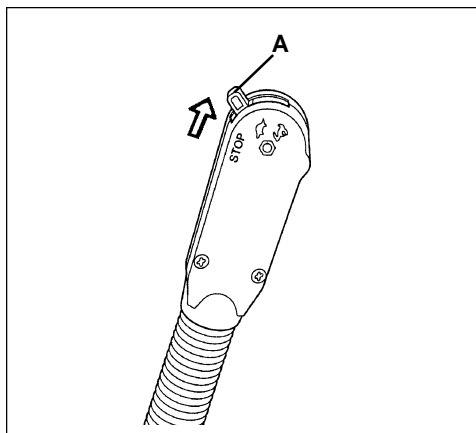

NOTE

Allow engine to warm up before use.

STARTING WARM ENGINE

1. Move throttle lever (A) to start/idle detent position, pull recoil starter handle (D) 5 times and engine should start. Do not use choke (C).

NOTE

If engine does not start after 5 pulls, use cold start procedures.

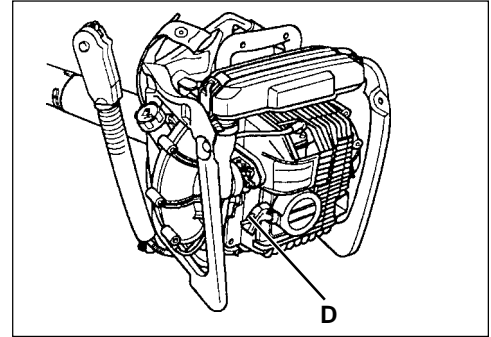

STOPPING ENGINE

1. Move throttle lever to idle detent position and allow engine to run at idle for a few minutes.
2. Move throttle lever (A) to "STOP" position.

WARNING DANGER

If engine does not stop, move choke lever to closed position to stall engine. Check and repair stop switch before starting engine again or serious personal injury may result.

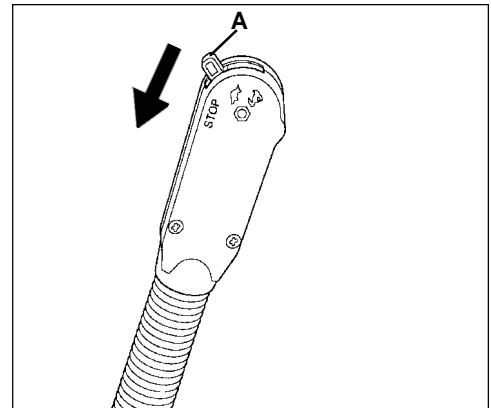

OPERATING BLOWER

WARNING DANGER

Always wear safety glasses, hearing protection, a face filter mask and take all safety precautions or serious personal injury may result.

Do not point the blower pipe in the direction of people or pets.

Read the Safety Section carefully.

IMPORTANT

To avoid engine damage due to over revving, do not block blower pipe opening.

1. Use only during appropriate hours.
2. Make sure bevel at end of pipe faces downward.
3. Allow the engine to warm up at a fast idle for a few minutes.
4. Set engine speed with throttle (A).

NOTE

The blower can be run at any speed between 2600 rpm to 6600 rpm (PB-46HT/LN); 7600 rpm (PB-60HT) once the engine has broken in after approximately 3 fuel tanks of running time.

5. Use lower speed to blow dry leaves from a lawn or flower bed.
6. Additional speed may be necessary to clean grass and leaves from walks, patios and drives.
7. Higher speed may be necessary to move gravel, dirt, snow, bottles or cans from a driveway, street, parking lot or stadium.

NOTE

Never use a higher speed setting than necessary to perform a task. Remember, the higher the engine speed, the louder the blower noise. Minimize dust by using blower at lower speeds and by dampening material with water/mist when necessary. Keep debris on your property.
Be Smart - be a good neighbor.

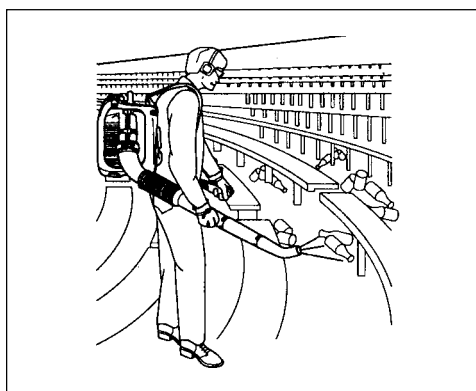
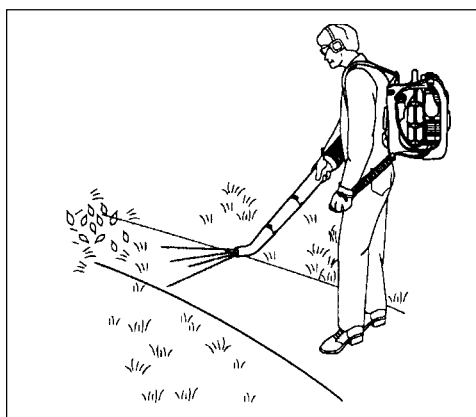
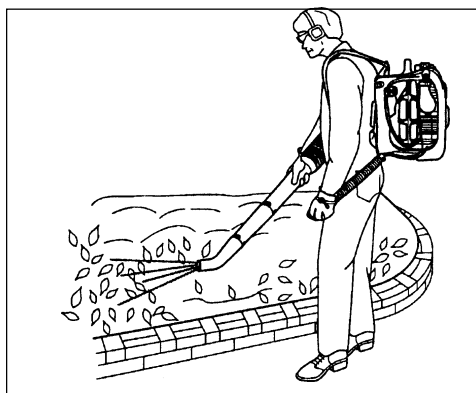
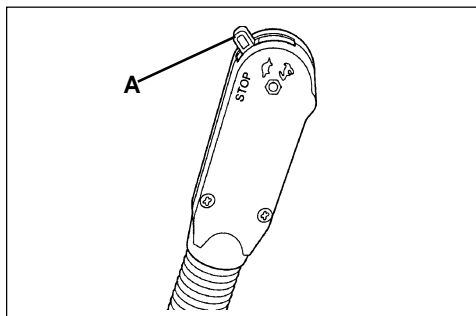

MAINTENANCE

Your ECHO blower is designed to provide many hours of trouble free service. Regular scheduled maintenance will help your blower achieve that goal. If you are unsure or are not equipped with the necessary tools, you may want to take your unit to an ECHO Service Dealer for maintenance. To help you decide whether you want to DO-IT-YOURSELF or have the ECHO Dealer do it, each maintenance task has been graded. If task is not listed, see your ECHO Dealer for repairs.

SKILL LEVEL

- Level 1**= Easy to do. Most required tools come with unit.
- Level 2**= Moderate difficulty. Some specialized tools may be required.
- Level 3**= Experience required. Specialized tools are required. Echo recommends the unit be returned to your Echo Dealer for servicing.

ECHO offers **REPOWER™** Maintenance Kits and Parts to make your maintenance job easier. Just below each task heading are listed the various part numbers required for that task. See your ECHO dealer for these parts.

MAINTENANCE INTERVALS

COMPONENT/ SYSTEM	MAINTENANCE PROCEDURE	REQ'D SKILL LEVEL	DAILY OR BEFORE USE	EVERY REFUEL	3 MONTHS OR 90 HOURS	6 MONTHS OR 270 HOURS	YEARLY
Recommended Echo Dealer Maintenance Procedures							
Cylinder Exhaust Port	Inspect/Clean/Decarbon	3			I / C		
Do-It-Yourself Maintenance Procedures							
Air Filter	Inspect/Clean/Replace	1	I / C		R*		
Choke	Inspect/Clean	2	I / C				
Fuel Filter	Inspect/Replace	1			I		R*
Fuel System, Leaks	Inspect/Replace	1	I	I / R*			
Cooling System	Inspect/Clean	2	I / C				
Muffler Spark Arrestor	Inspect/Replace	2			I / R*		
Recoil Starter Rope	Inspect/Clean	1	I / C				I / R*
Spark Plug	Inspect/Clean	2			I / C	R*	
Screws/Nuts/Bolts	Inspect/Tighten/Replace	1	I / R*				

MAINTENANCE PROCEDURE LETTER CODES: I = INSPECT, R = REPLACE, C = CLEAN

IMPORTANT NOTE - Time intervals shown are maximum. Actual use and your experience will determine the frequency of required maintenance.

MAINTENANCE PROCEDURE NOTES:

* All recommendations to replace are based on the finding of damage or wear during inspection.

AIR FILTER

Level 1.

Tools required: 25mm-50mm (1in.-2in.) medium bristle paint brush.

Parts required: None.

NOTE

Clean daily.

1. Close choke, remove air cleaner cover and air filter.
2. Brush dust off filter.

LN Models Only:

3. Wash diffuser screen in suitable solvent.
4. Dry screen before reinstalling.

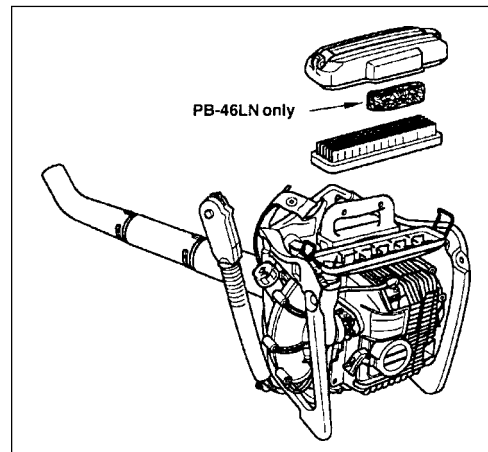
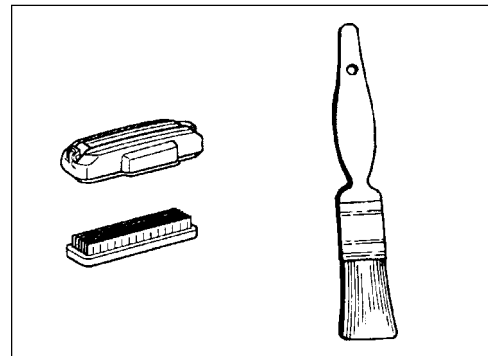

FUEL FILTER

Level 1.

Tools required: Fuel line hook. 203-254mm (8in.-10in.) length of wire with one end bent into a hook. Clean rag, funnel, and an approved fuel container.

Parts required: Fuel Filter P/N 13120530830

WARNING DANGER

Fuel is **VERY** flammable. Use extreme care when mixing, storing or handling.

1. Use a clean rag to remove loose dirt from around fuel cap and empty fuel tank.
2. Use the "fuel line hook" to pull the fuel line and filter from the tank.
3. Remove the filter from the line and install the new filter.

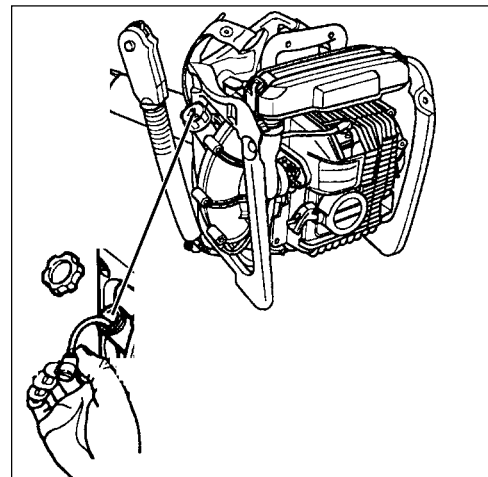
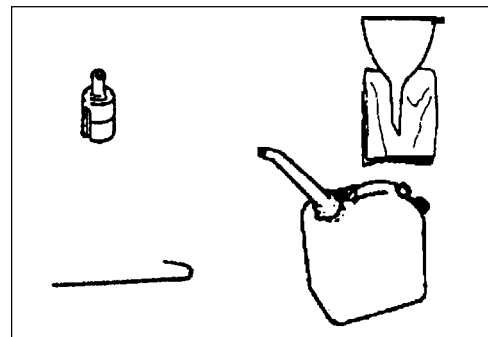

SPARK PLUG

Level 2.

Tools required: 3/4" Spark Plug deep socket, Feeler gauge (preferably a wire gauge),

Parts Required: Spark Plug, NGK BPM-7Y, P/N 99944500071

1. Remove spark plug (LN models; spark plug cover and spark plug), and check for fouling, worn and rounded center electrode.
2. Clean the plug or replace with a new one. **DO NOT** sand blast to clean. Remaining sand will damage engine.
3. Adjust spark plug gap by bending outer electrode.
4. Tighten spark plug to 145-155 kg/cm (125-135 in. lb.).
5. Install spark plug cover (LN models).

IMPORTANT

Always reinstall spark plug cover on LN models, otherwise engine cooling is greatly reduced, and will cause engine failure.

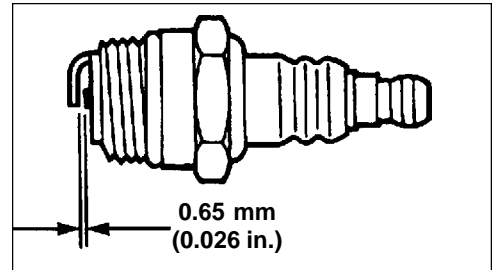
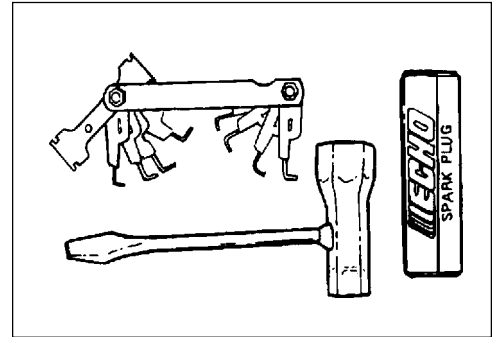

COOLING SYSTEMS CLEANING

Level 3.

Tools required: 25mm-50mm (1in.-2in.) medium bristle paint brush, Cross Head Screwdriver, Pointed Wood Stick.

Parts Required: None, if you are careful.

IMPORTANT

To maintain proper engine operating temperatures, cooling air must pass freely through the cylinder fin area. This flow of air carries combustion heat away from the engine.

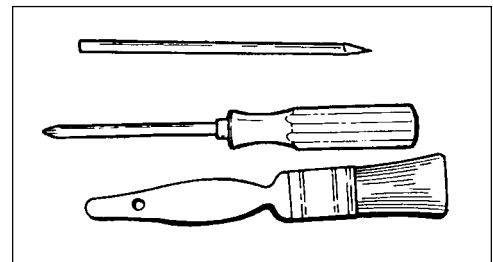

Overheating and engine seizure can occur when:

- Air intakes are blocked, preventing cooling air from reaching the cylinder.
- Dust and grass build up on the outside of the cylinder. This build up insulates the engine and prevents the heat from leaving.

Removal of cooling passage blockages or cleaning of cooling fins is considered "Normal Maintenance". Any failure attributed to lack of maintenance is not warranted.

Cleaning Grill

1. Remove accumulated debris from intake grill between backpack frame and blower housing.

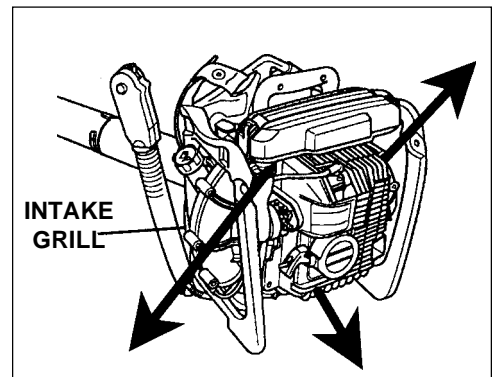

Cleaning Cylinder Fins

PB-46LN

1. Remove spark plug cover and spark plug.
2. Remove engine cover (five screws), pull cover away from engine and tie knot in starter rope. Clean cylinder fins to allow cooling air to pass freely.

PB-46HT; PB-60HT

1. Remove engine cover (five screws), pull cover away from engine and tie knot in starter rope. Clean cylinder fins to allow cooling air to pass freely.

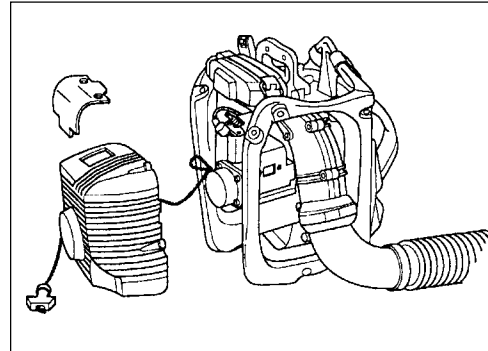

EXHAUST SYSTEM

Spark Arrestor Screen

Level 2.

Tools required: Cross Head Screwdriver, Pointed Wood Stick, Soft metal brush,

Parts Required: Spark arrestor screen P/N 14586221060,
(2) Gaskets P/N 14586621060

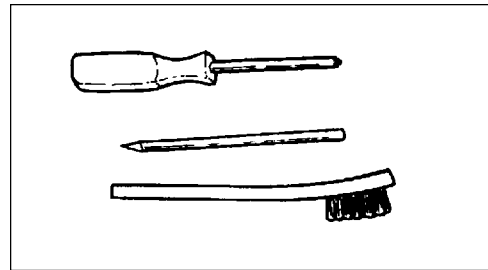

IMPORTANT

Carbon deposits in muffler will cause a drop in engine output and overheating. Spark arrestor screen must be checked periodically.

1. Remove spark plug and engine covers (five screws).
2. Remove spark arrestor cover (A), gaskets (B) and spark arrestor screen (C) from muffler. Replace screen if plugged with carbon deposits.
3. Install spark arrestor screen, gaskets, and cover.
4. Install spark plug and engine covers.

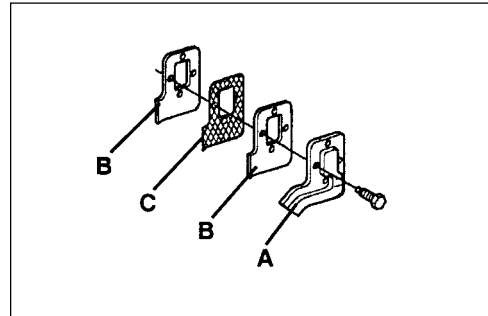

CARBURETOR ADJUSTMENT - GENERAL

Level 2.

Tools required: Screwdriver, tachometer (Echo P/N 99051130017)

Parts required: none.

NOTE

Do not adjust carburetor unless necessary. If you have difficulty, see your ECHO dealer.

Adjustment Screws

- | | |
|---------------------|---|
| Idle Speed (A) | Control throttle opening at idle. |
| Low (LO) Speed (B) | Controls amount of fuel at low speed and supplementary fuel for smooth progression from idle to high speed. |
| High (HI) Speed (C) | Controls amount of fuel at full throttle |

Before Adjustment

Check that:

- Air filter is clean and properly installed.
- Spark arrestor screen and exhaust port are free of carbon
- Blower pipes are installed

Initial Adjustment

1. With engine off, turn HI speed screw (C) counterclockwise to stop.
2. Turn LO speed screw (B) midway between stops.
3. Turn idle screw (A) until tip of screw just touches throttle plate; then turn three (3) turns clockwise.

Final Adjustment

IMPORTANT

Limiters prevent exceeding C.A.R.B. and E.P.A. emission limits and over rich adjustment, but **not** over lean adjustment, which can cause engine failure: Do not exceed recommended HI speed engine R.P.M. during operation, or for long periods during adjustment.

1. Start engine, run at idle for one minute.
2. Complete warm up by running at full throttle for 5 minutes, operating choke twice to clear air from carburetor chambers.
3. Run at idle and accelerate to check for smooth transition from idle to high speed; if engine hesitates, turn LO speed screw (B) counterclockwise 1/8th of a turn at a time until acceleration is smooth.
4. Use a tachometer to adjust idle speed to specifications found on page 11.

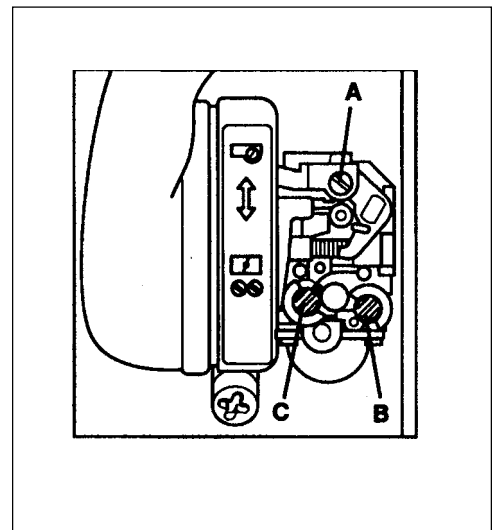
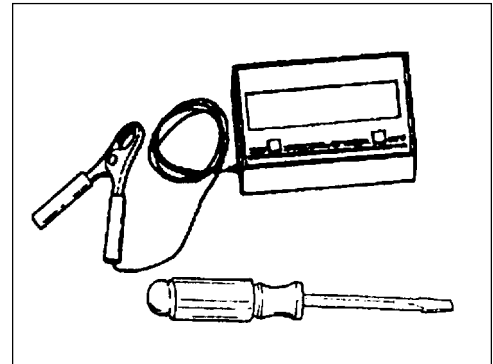

TROUBLESHOOTING

Problem				
Engine - starts hard				
Engine - does not start			Cause	Remedy
Engine Cranks	Fuel at carburetor	No fuel at carburetor	Fuel strainer clogged Fuel line clogged Carburetor	Clean Clean See your ECHO dealer
	Fuel at cylinder	No fuel at cylinder	Carburetor	See your ECHO dealer
		Muffler wet with fuel	Fuel Mixture is too rich	Open choke Clean/replace air filter Adjust carburetor See your ECHO dealer
	Spark at end of plug wire	No spark at end of plug wire	Stop switch off Electrical problem Interlock switch	Turn switch on See your ECHO dealer See your ECHO dealer
	Spark at plug	No spark at plug	Spark gap incorrect Covered with carbon Fouled with fuel Spark plug defective	Adjust 0.65mm (0.026in.) Clean or replace Clean or replace Replace plug
Engine does not crank			Internal engine problem	See your ECHO dealer
Engine runs	Dies or accelerates poorly		Air filter dirty Fuel filter dirty Fuel vent plugged Spark plug Carburetor Cooling system plugged Exhaust port/spark arrestor screen plugged	Clean or replace Replace Replace Clean and adjust/replace Adjust Clean Clean
Engine runs properly	Blower does not work, is weak or uneven		Blower Pipe clogged, loose or damaged	Unclog Tighten Replace

STORAGE

Long Term Storage (Over 30 Days)

Do not store your unit for a prolonged period of time (30 days or longer) without performing protective storage maintenance which includes the following:

1. Store unit in a dry, dust free place, out of the reach of children.

WARNING  **DANGER**

Do not store in enclosure where fuel fumes may accumulate or reach an open flame or spark.

2. Place the stop switch (A) in the "STOP" position.
3. Remove accumulation of grease, oil, dirt and debris from exterior of unit.
4. Perform all periodic lubrication and services that are required.
5. Tighten all screws and nuts.
6. **Drain** the fuel tank **completely** and pull the recoil starter handle several times to remove fuel from the carburetor.
7. Remove the spark plug (LN models: spark plug cover and spark plug) and pour 7cc (1/4 oz., 1/2 tablespoon) of fresh, clean ECHO 2-stroke engine oil into the cylinder through the spark plug hole.
 - A. Place a clean cloth over the spark plug hole.
 - B. Pull the recoil starter handle 2-3 times to distribute the oil inside the engine.
 - C. Observe the piston location through the spark plug hole. Pull the recoil handle slowly until the piston reaches the top of its travel and leave it there.
8. Install the spark plug (do not connect ignition cable).
9. Remove blower pipe assembly from unit.

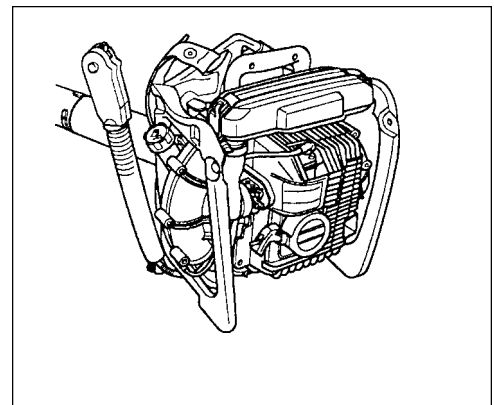
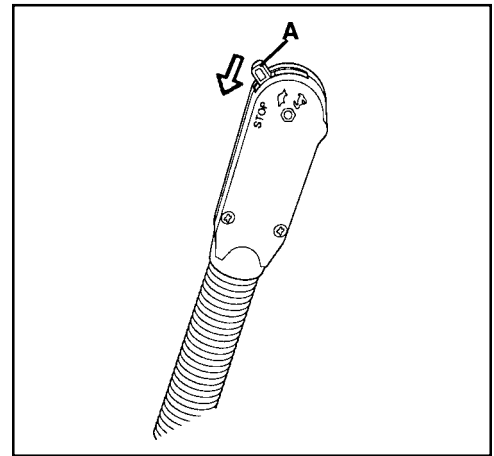

IMPORTANT

Always reinstall spark plug cover on LN models, otherwise engine cooling is greatly reduced, and will cause engine failure.

SERVICING INFORMATION

PARTS

Genuine ECHO Parts and ECHO Re Power Parts and Assemblies for your ECHO products are available only from an Authorized ECHO Dealer. When you do need to buy parts **always** have the Model Number, Type number and Serial Number of the unit with you. You can find all three numbers on the fan housing underneath the engine cover. For future reference, write them in the space provided below.

Model No. _____ Type No. _____ SN. _____

SERVICE

Service of this product during the warranty period must be performed by an Authorized ECHO Service Dealer. For the name and address of the Authorized ECHO Service Dealer nearest you, ask your retailer or call: 1-800-432-ECHO (3246). When presenting your unit for Warranty service/repairs, proof of purchase is required.

ECHO CUSTOMER ASSISTANCE --

If you require assistance or have questions concerning the application, operation or maintenance of this product you may call the ECHO Customer Assistance Department at 1-800-673-1558 from 8:00 am to 5:00 pm (Central Standard Time) Monday through Friday. Before calling, please know the model and serial number of your unit to help your Customer Assistance Representative.

WARRANTY CARD

This card is our means of registering all original owners of ECHO equipment. The card plus proof of purchase provides you the assurance that authorized warranty work will be done. It also provides a direct link between you and ECHO if we find it necessary to contact you.

ADDITIONAL OR REPLACEMENT MANUALS

Operators and Parts Manuals are available for purchase from your ECHO dealer or directly from ECHO. [See ordering instructions at the end of this manual.]

ORDERING INSTRUCTIONS

To obtain a Parts Catalog or Operator's Manual send a check or money order for \$2.00 per Parts Catalog or \$1.50 per Operator's Manual made payable to ECHO, INCORPORATED. State on a sheet of paper model number and serial number of the ECHO unit you have, part number of the manual (if known), your name and address and mail to address above:

Available Parts Lists

PB-46HT	Type 1E	S/N 001001 & UP	Part Number 99922202821
PB-46LN	Type 1E	S/N 001001 & UP	Part Number 99922202834
PB-60HT	Type 1E	S/N 001001 & UP	Part Number 99922202822

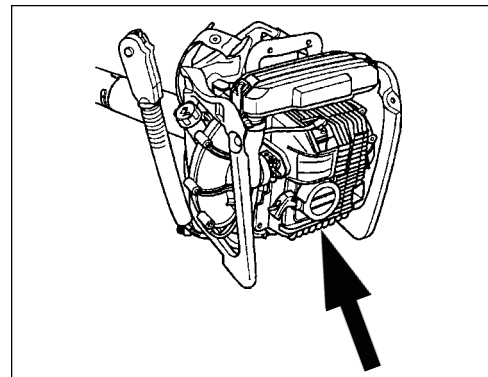

DEALER?
Call
1-800-432-ECHO

CUSTOMER ASSISTANCE
1-800-673-1558
8 - 5 Mon - Fri C.S.T.

ECHO LIMITED WARRANTY REGISTRATION CARD / TARJETA DE INSCRIPCIÓN DE GARANTÍA LIMITADA	
(Copy of Limited Warranty Statement included with Owner's Manual) / (Copia de Manual del Operador o tarjeta con copia de la Declaración de la Garantía Limitada)	
Please Print/Imprimir Nombre, Dirección, Cita y Hora de Compra	
Purchased/Comprado el (Mes/Año) de (Ciudad/Estado/Provincia)	
Address/Dirección	
City/Ciudad	
State/Estado	
Zip/Code/Código Postal	
Phone/Telefono	Date of Purchase/Fecha de Compra
Name/Nombre Where Purchased	Dealer Name/Nombre del Distribuidor
Model Number/Numero del Modelo	Serial No./Número de Serie
Customer Signature/ Firma del Cliente	Dealer Signature/ Firma del Distribuidor (If Applicable)
Do not write in this area.	

A. Primary use of tool/uso principal de la herramienta:
1. 1. Hacer trabajos 2. 2. Jardinero 3. 3. Profesional
Dentro de casa Externo de jardín

B. Safety/operational information received with product? / ¿Qué información de operación/mantenimiento recibió con el producto?
1. 1. Operator's Manual 2. 2. Safety glasses
Manual del Operador Goggles

C. Have you reviewed the Brush Cutter/Foremower Safety Video coverage? / ¿Ha visto el video de seguridad para información general sobre el cortador de maleza/seguridad?
1. 1. 999034 2. 2. 100

TO PURCHASE A COPY OF THE ECHO SAFETY VIDEO / OBTENER UNA COPIA DEL VIDEO DE SEGURIDAD:
FOR INFORMATION ONLY / PARA INFORMACIÓN ÚNICAMENTE
ECHO, INCORPORATED
ATTN: VIDEO ORDER
DE CALUMET, ILL.
LAKE ZURICH, IL 60047-1564

ECHO Incorporated
400 Oakwood Road
Lake Zurich, IL 60047
Technical Publications Orders

ECHO
ECHO, INCORPORATED
400 Oakwood Road
Lake Zurich, IL 60047