

# GIGABYTE

T E C H N O L O G Y



## **Super G Wireless PCI Adapter**

GN-WP01GT

## **User's Guide**

October 2004 - Revision 1.0

# Contents

<b>Chapter 1</b>	<b>Introduction .....</b>	<b>5</b>
	Overview .....	5
	Key Features.....	5
	Package Contents .....	6
	Operating Modes .....	6
	LED .....	7
	System Requirements.....	7
<b>Chapter 2</b>	<b>Installation .....</b>	<b>8</b>
	Installing PCI Adapter .....	8
	Hardware Installation .....	8
	Installing the Driver and Utility.....	9
	SmartSetup 3 .....	14
<b>Chapter 3</b>	<b>Configuration .....</b>	<b>17</b>
	Using the GIGABYTE Wireless Utility.....	17
	Current Status Tab .....	17
	Site Survey Tab.....	21
	Profile Management Tab .....	22
	Diagnostics Tab.....	35
	Advanced Statistics .....	36
	Adapter Information Tab .....	39
	<b>Appendix A FAQ.....</b>	<b>40</b>
	<b>Appendix B Wireless Security .....</b>	<b>41</b>

**Appendix C Troubleshooting..... 42**  
**Appendix D Glossary..... 43**  
**Appendix E Specifications ..... 46**  
**Appendix F Regulatory Information ..... 48**  
**Appendix G Warranty ..... 50**

**Federal Communication Commission Interference Statement:**

This equipment has been tested and found to comply with the limits for a Class B digital device, pursuant to Part 15 of the FCC Rules. These limits are designed to provide reasonable protection against harmful interference in a residential installation. This equipment generates, uses and can radiate radio frequency energy and, if not installed and used in accordance with the instructions, may cause harmful interference to radio communications. However, there is no guarantee that interference will not occur in a particular installation. If this equipment does cause harmful interference to radio or television reception, which can be determined by turning the equipment off and on, the user is encouraged to try to correct the interference by one of the following measures:

- Reorient or relocate the receiving antenna.
- Increase the separation between the equipment and receiver.
- Connect the equipment into an outlet on a circuit different from that to which the receiver is connected.
- Consult the dealer or an experienced radio/TV technician for help.

**FCC Caution:**

To assure continued compliance, any changes or modifications not expressly approved by the party responsible for compliance could void the user's authority to operate this equipment.

This device complies with Part 15 of the FCC Rules. Operation is subject to the following two conditions: (1) This device may not cause harmful interference, and (2) this device must accept any interference received, including interference that may cause undesired operation.

**IMPORTANT NOTE****FCC Radiation Exposure Statement:**

This equipment complies with FCC radiation exposure limits set forth for an uncontrolled environment. End users must follow the specific operating instructions for satisfying RF exposure compliance.

This transmitter must not be co-located or operating in conjunction with any other antenna or transmitter.

# Chapter 1

## Introduction

### Overview

---

The GIGABYTE WP01GT Super G PCI Adapter with SmartSetup 3 delivers to you with today's fastest available wireless connection.

The WP01GT Super G Wireless Adapter communicates over the 2.4GHz 802.11g wireless standard with throughput up to 15 times faster than the 11Mbps 802.11b while still remaining fully backward compatible with that standard.

Desktops PC's equipped with wireless adapters communicate with Wi-Fi Application Points and wireless routers giving you the freedom from having to run Ethernet cabling. The WP01GT has powerful security features and lightening fast speed, moving files, watching streaming video and downloading MP3's faster than ever.

The WP01GT supports 64/128/152-bit WEP encryption, 802.1x RADIUS authentication and WPA support, giving you complete peace of mind over data security.

With SmartSetup 3 built-in setting up and configuring a secure wireless network has never been easier. SmartSetup 3 takes all the guesswork and mystery away, giving you a bullet-proof WPA connection generally in less than two minutes. No pushing buttons, no fussing with technical support – three steps and you're done.

Get ready to join the wireless revolution, made easy by GIGABYTE.

### Key Features

---

- Connects to any 802.11b, and 802.11g wireless network
- Data rates up to 108Mbps in Super G mode
- Dynamic rate shifting ensures fastest possible connection
- 64/128/152-bit WEP encryption, 802.1x and WPA/ WPA2/ WMM support
- External antenna with reversible SMA

\*Theoretical throughput based on doubling of the 54Mbps radio channel.

## Package Contents

---

- GN-WP01GT Super G Wireless PCI Adapter with antenna
- User Guide on CD-ROM
- GN-WP01GT Quick Start Guide
- Smartsetup3 Quick Start Guide (Only work with GIGABYTE Router)
- Low profile bracket

If there are any missing or damaged parts, please contact your local distributor or dealer immediately.

## Operating Modes

---

The GN-WP01GT PCI Adapter can operate in three modes:

- **802.11b** (11b) – 2.4GHz 11Mbps. This radio has a range of about 50 meters and a maximum throughput of 11 Mbit/s. Although it's slower than 11g, it's still the most commonly used network today.
- **802.11g** (11g) – 2.4GHz 54Mbps. In June 2003, a third standard for Wi-Fi was ratified: 802.11g. This version works in the 2.4 GHz band (like 802.11b) but operates at 54 Mbit/s raw, throughput like 802.11a. It is fully backwards compatible with 11b and uses the same frequencies.
- **Super G** - The Super G is a set of technologies was invented by the Atheros Company to double the throughput of the 54Mbps promised by the IEEE 802.11g wireless standard. To use Super G, not only your PCI Adapter but your wireless Router or AP must also support the Atheros Super G functionality.

These and other advanced configuration options are explained further in **Chapter 3 - Configuring the WP01GT**.

## LED

---

The WP01GT has one LED on the bracket next to the external antenna. The LED is the Receive/Transmit indicator. Please see Figure 1 below.

LED Activities	Definition
Steady blink	Looking for network association
Random blink	Associated with network. Blinking increases with activity on network
OFF	No Power
Slow blink	Power save mode

Figure 1 – Adapter LED

## System Requirements

---

For trouble free installation and operation, please assure your PC meets the following minimum system requirements:

- Desktop PC with a Pentium 300Mhz or higher compatible processor with an available PCI slot.
- A CD-ROM drive
- 20 Mbytes of hard disk space

# Chapter 2 Installation

## Installing PCI Adapter

---

This chapter covers the installation of the WP01GT Adapter for your desktop PC. The following sections will assist you with proper installation of the PCI Adapter, and also with installing the necessary drivers and utilities.

### Hardware Installation

You will need a Phillips head screwdriver to perform the installation as described below:

Step 1: Power OFF your PC.

Step 2: Plug the PCI Adapter into an open PCI slot on the motherboard by pressing the card gently until the card edge connector is completely and firmly inserted into your motherboards PCI slot.

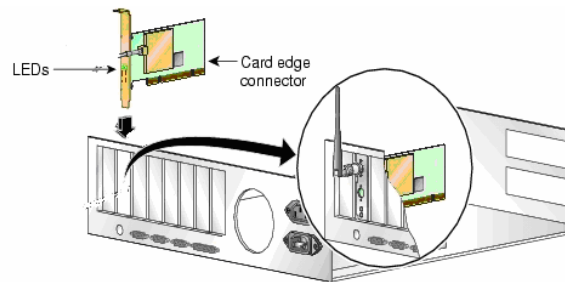

Figure 2. Insert your PCI Adapter

Step 3: Once inserted, attach the antenna on the mount of the PCI Adapter by screwing it on clockwise as shown in the figure below.



## Super G Wireless PCI Adapter

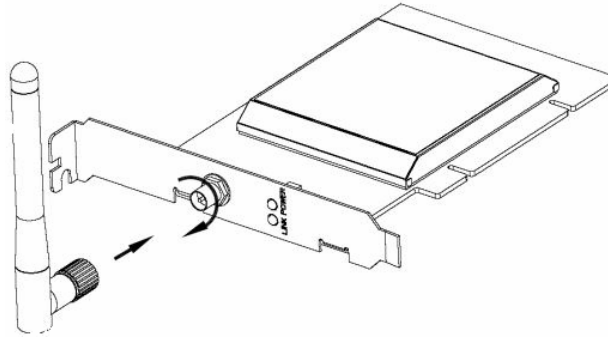

Figure 3. Attach the high gain antenna

## Installing the Driver and Utility

This section covers installation of the WP01GT wireless drivers and utility. You should use the drivers that are included on the CD-ROM rather than the default Windows drivers. The GIGABYTE WMAG drivers have special features and utilities that give you more stability and security than Windows's default "Wireless Zero Configuration".

Step 1: Upon starting your PC, the **Windows Found New Hardware** wizard will open. Click **Cancel** to close this window.

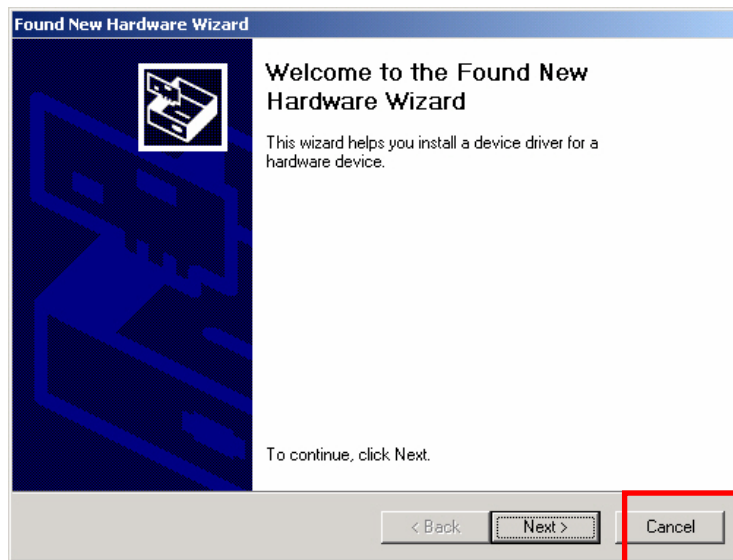

Figure 4. Found New Hardware Screen

Step 2: Insert the WP01GT Setup CD into the CD-ROM drive. The Welcome screen will automatically open.

Step 3: From the main menu, click **Install Driver & Utility**.

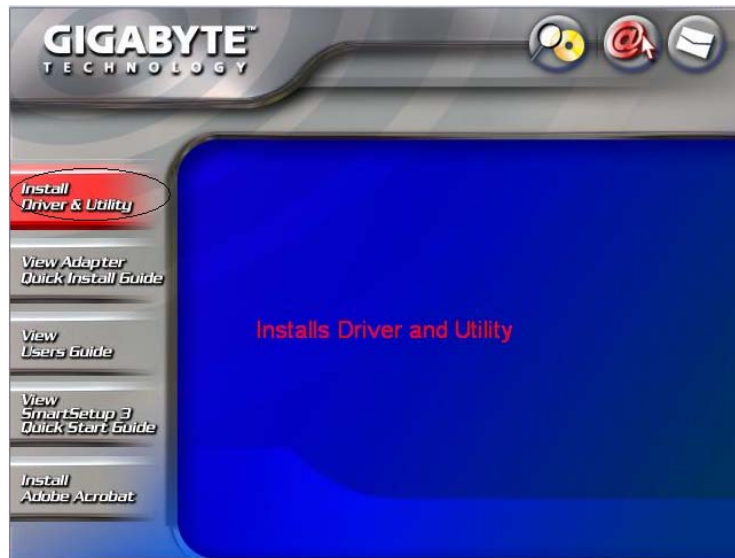

Figure 5. WP01GT Welcome Screen

## Super G Wireless PCI Adapter

Step 4: InstallShield will install the WP01GT drivers. Click **Next** to proceed.

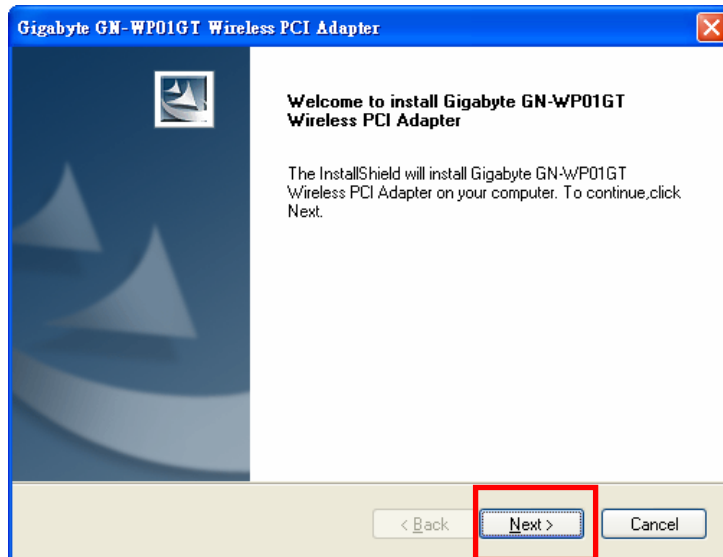

Figure 6. InstallShield

Step 4: Setup will detect your operating system.

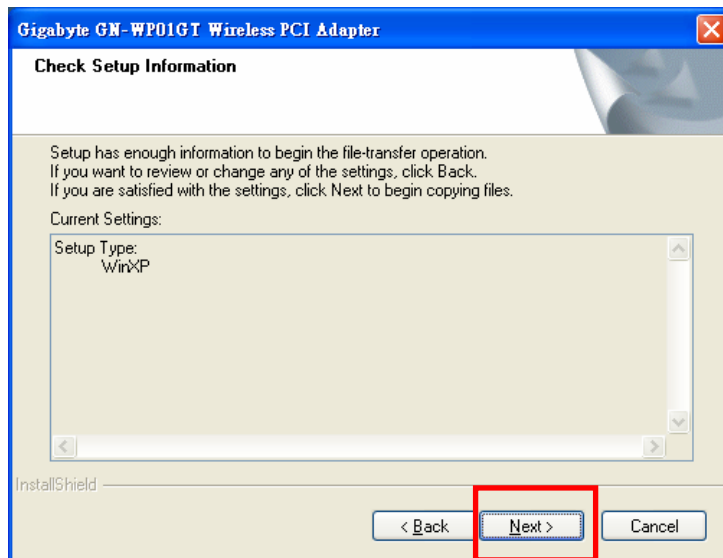

Figure 7. InstallShield Detect Windows OS

Step 5: If you receive the message *Windows Logo Testing*, click **Continue Anyway**

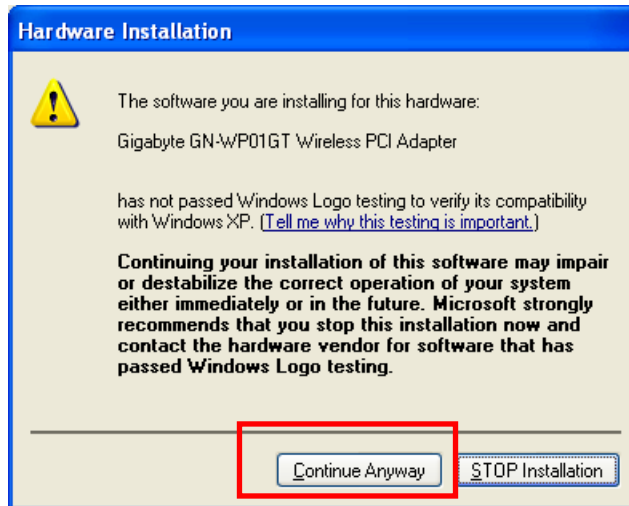

Figure 8. Windows Logo Testing

Step 6: Click **Finish** to complete installation.

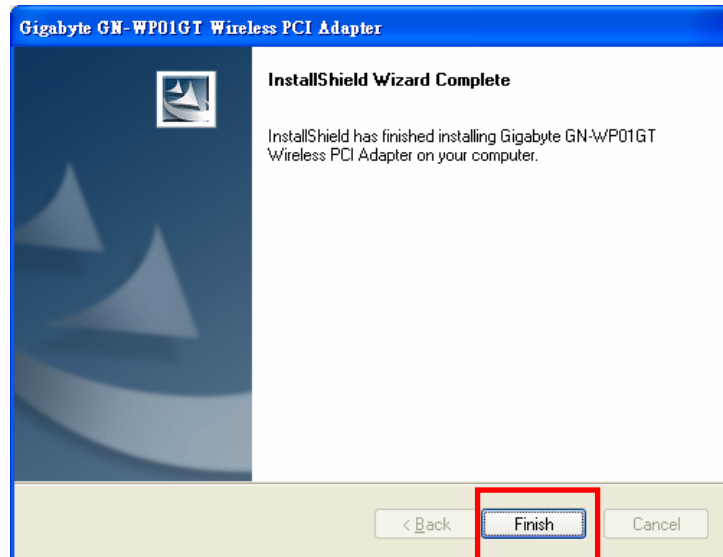

Figure 9. InstallShield Complete

## Super G Wireless PCI Adapter

If there is a wireless network in the vicinity, the WP01GT will automatically associate and display the new wireless connection in your system tray. Also note the GIGABYTE wireless utility represented by the four green bars.

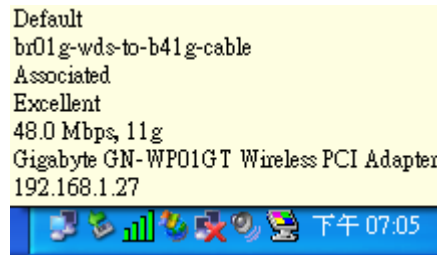

Figure 10. New Wireless Connection Icon

**Congratulations. Installation of your Wireless Adapter is complete.**

- i** The GIGABYTE WP01GT default wireless settings are: Infrastructure Mode, NO security, accepts all 2.4GHz wireless traffic, Super G mode ON, and power save mode = 'normal'. To change these or other settings, please see **Configuring the WP01GT** in Chapter 3.



## SmartSetup 3

---

Note: The following section applies to users of GIGABYTE Wireless Routers.

GIGABYTE SmartSetup 3 is a powerful, yet user-friendly wireless network configuration wizard specially designed for GIGABYTE wireless networks. If you are connecting to a GIGABYTE wireless router, SmartSetup 3 will detect this and activate.

In three easy steps, you can establish a bulletproof WPA wireless network AND configure your Internet connection. Only GIGABYTE delivers this easy, powerful and secure solution for your wireless network!

Step 1: Select the GIGABYTE wireless router from the available networks.

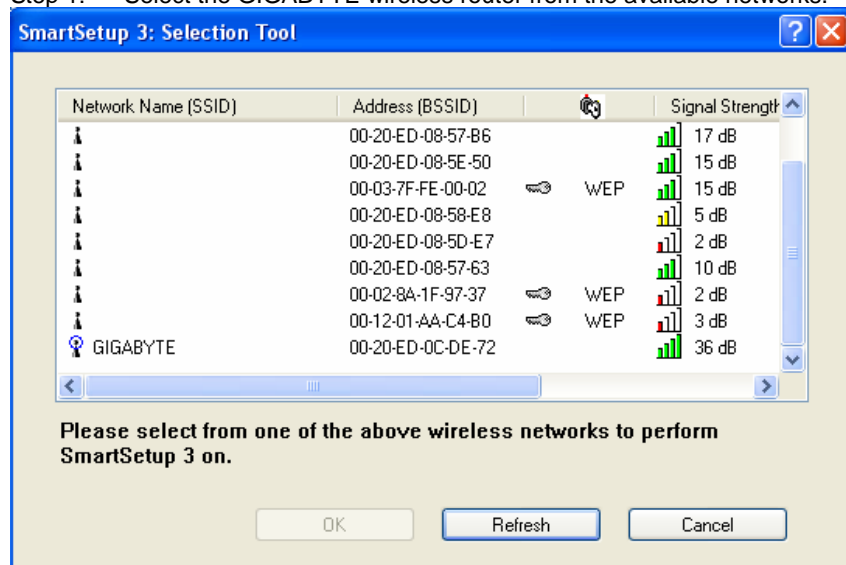

Figure 11. SmartSetup 3 Network Selection

Step 2: Create a WPA Passphrase using any keyboard character. Make it no less than 8 but no more than 63 characters in length. Anyone wishing to gain access to your network, will first need to key-in this Passphrase. In the example below, we used 'I love green eggs and ham'.

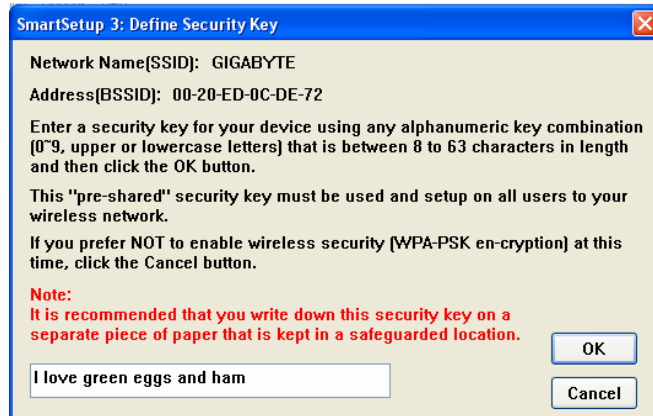

Figure 12. SmartSetup 3 Define Passphrase

Step 3: Your GIGABYTE router's web configuration utility will automatically open, and detect your ISP type. Just key in the Username and Password. **Done.**

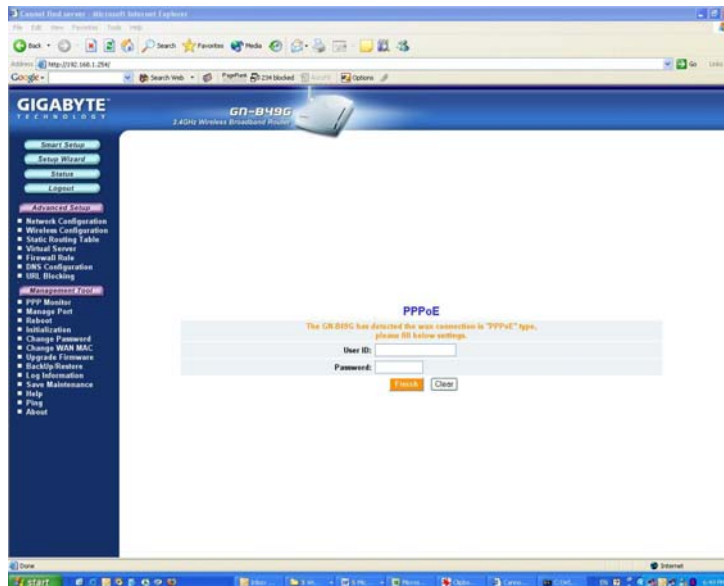

Figure 13. Auto detecting your ISP type

Note: If Figure 13 does not appear, please type 192.168.1.254 in the address bar of your web browser, and click "Smart Setup" from the main menu which displays. For more information about SmartSetup 3, please see the enclosed Quick Start Guide.

**Congratulations. Your secure WPA wireless LAN and Internet**



## Chapter 3 Configuration

### Using the GIGABYTE Wireless Utility

---

This chapter explains how to use GIGABYTE Wireless Utility to view the client adapter's status, and transmit and receive configuration settings. The following topics are covered in this chapter:

**Current Status** - Displays the complete operation state of the WP01GT

**Site Survey** - Displays all visible AP's in the immediate wireless network.

**Profile Management** – Create and modify connection configuration in a “Profile”

**Diagnostics** - Displays details regarding network connection health, and performance.

**Information** - Displays the card name, MAC ID, date and versions of the driver.

In addition to enabling you to configure your Adapter for use in various types of networks, GIGABYTE Wireless Utility provides tools that enable you to assess the performance of the Adapter and other devices on the wireless network.

### Current Status Tab

---

GIGABYTE Wireless Utility Link Information screen displays network mode, signal strength, and link quality information about the current connection. To view your Adapter's status and settings, open GIGABYTE Wireless Utility. The Current Status Tab appears (see Figure 14).

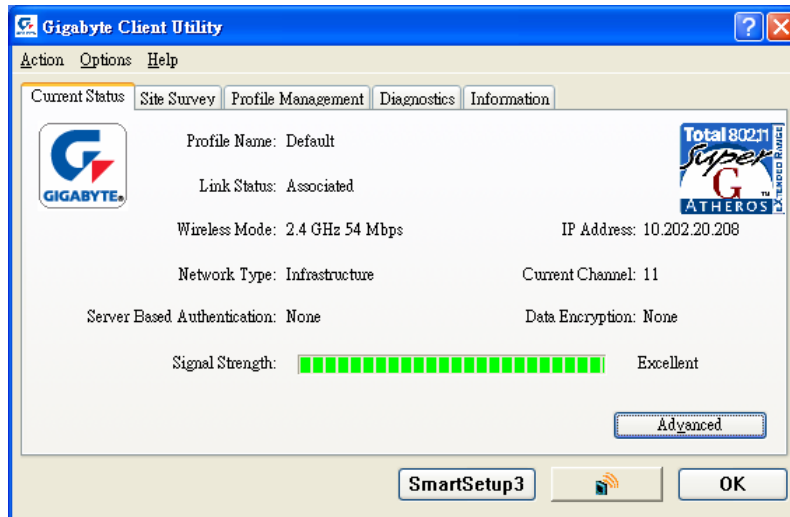

Figure 14. Link Status Tab

**Profile Name** – Network configuration (Profile) your Adapter is currently using. Creating and modifying a profile is done from the Profile Management Tab.

**Link Status** – Displays the association status of the Adapter to a network. (Not Associated, Associated, Authenticating, Authenticated, Authentication Failed, Authentication Failed Retrying)

**Wireless Mode** – The frequency and rate which your current wireless connection is capable of transmitting or receiving packets.

**Network Type** – Displays the network connection type, options are Ad-hoc and Infrastructure.

**Server Based Authentication** – Indicates if an 802.1X compliant RADIUS authentication server is utilized.

**IP Address** – The unique Internet Protocol ID for the Adapter.

**Current Channel** – The wireless radio channel being used for the data transmission.

**Data Encryption** – Type of encryption currently in use (if any) Ad-hoc.

**Signal Strength** – The length of the green bar represents relative wireless network signal strength.

Click **Advanced** if you want to view more detailed status information for your client adapter. The Advanced Status window appears (see Figure 15).

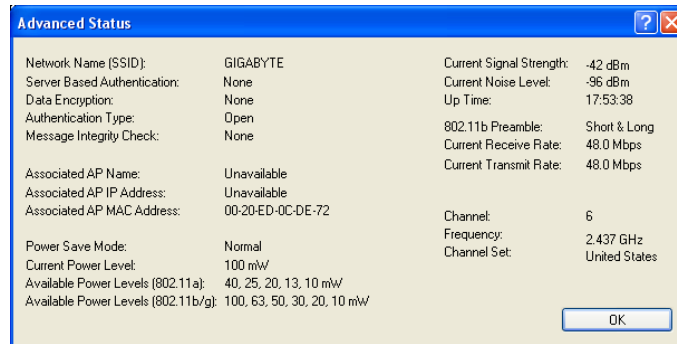

Figure 15 – Advanced Status Window

**Network Name (SSID)** - The name of the network to which your client adapter is currently associated.

**Server Based Authentication** - The method by which authentication to a back-end server is being performed to establish secure connectivity. (None, LEAP, EAP-TLS, PEAP (EAP-GTC), or PEAP (EAP-MSCHAP V2))

**Data Encryption** - The data encryption type that was negotiated with the access point (in infrastructure mode) or another client (in ad hoc mode) upon association. (None, WEP, CKIP, or TKIP)

**Authentication Type** - Specifies whether the client adapter must share the same WEP keys as the access point in order to authenticate or can authenticate to the access point regardless of its WEP settings. (Open or Shared)

**Message Integrity Check** - Indicates whether your client adapter is using message integrity check (MIC) to protect packets sent to and received from the access point.

MIC prevents bit-flip attacks on encrypted packets. During a bit-flip attack, an intruder intercepts an encrypted message, alters it slightly, and retransmits it, and the receiver accepts the retransmitted message as legitimate.

**Associated AP Name** - The name of the access point to which your client adapter is associated. It is shown only if the client adapter is in infrastructure mode.

Note: This field shows up to 15 characters although the name of the access point may be longer.

**Associated AP IP Address** - The IP address of the access point to which your client adapter is associated. It is shown only if the client adapter is in infrastructure mode.

**Associated AP MAC Address** - The MAC address of the access point to which your client adapter is associated. It is shown only if the client adapter is in infrastructure mode.

**Power Save Mode** - The client adapter's current power consumption setting. (CAM (Constantly Awake Mode), Max PSP (Max Power Saving), or Fast PSP (Power Save Mode))

**Current Power Level** - The power level at which your client adapter is currently transmitting. The maximum level is dependent upon the radio band used and your country's regulatory agency. (10, 20, 30, 50, 63, or 100 mW (802.11b/g band))

**Available Power Levels** - The power levels at which your client adapter is capable of transmitting. The maximum level is dependent upon the radio band used and your country's regulatory agency. 10, 20, 30, 50, 63, or 100 mW (802.11b/g))

**Current Signal Strength** - The signal strength for all received packets. The higher the value, the stronger the signal. (0 to 100% or 0 to -100 dBm)

**Current Signal Quality** - The signal quality for all received packets. The higher the value, the clearer the signal. (0 to 100%)

**Current Noise Level** - The level of background radio frequency energy in the current radio band. The lower the value, the less background noise present. (0 to -100 dBm)

**Up Time** - The amount of time (in hours:minutes:seconds) since the client adapter has been receiving power. If the adapter has been running for more than 24 hours, the time is displayed in days, hours:minutes:seconds.

**802.11b Preamble** - Indicates whether your client adapter is using only long radio headers or short and long radio headers. (Short & Long or Long Only)

**Current Link Speed** - The rate at which your client adapter is currently transmitting data packets. (1, 2, 5.5, 6, 9, 11, 12, 18, 24, 36, 48, or 54 Mbps)

**Channel** - The channel that your client adapter is currently using for communications. This field displays Scanning while the client adapter

searches for a channel.

**Frequency** - The radio frequency that your client adapter is currently using for communications. This field displays "Scanning" while the client adapter searches for a frequency.

**Channel Set** - The regulatory domain for which your client adapter is currently configured. This value is not user selectable. ( America, EMEA, Japan, or Rest of World)

Click **OK** to close the Advanced Status window.

## Site Survey Tab

The Site Survey screen displays a list of infrastructure and Ad-hoc networks available for connection in the "Network Name" column. To connect to a network, simply click on the network name, and press the **Activate** button. Note that secure networks (represented by the key icon) will require a Passphrase.

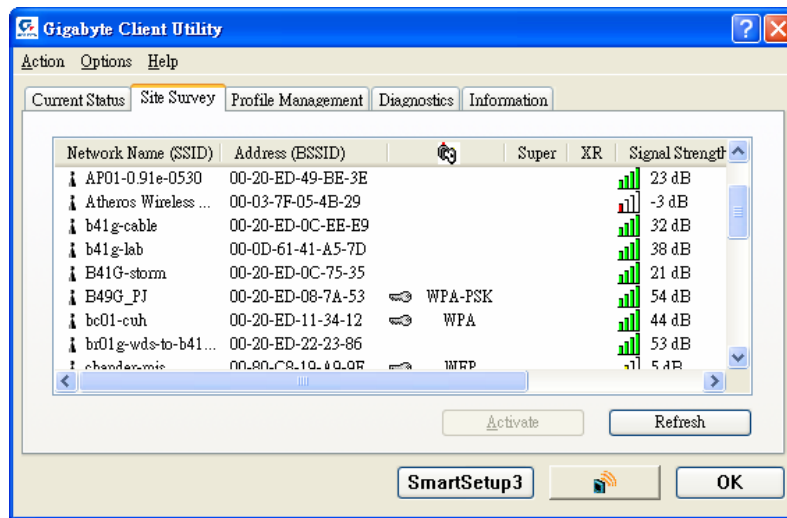



Figure 16. Site Survey Tab

**Network Name** – The SSID or unique name of the wireless network.

**Key Icon**  - Indicates a secure or open network

**Signal Strength** – The strength of signal, reported in dB.

**Channel** – The channel upon which the network broadcasts.

**Wireless Mode** – The radio frequency which the network broadcasts.

## Profile Management Tab

---

Every session runs under a Profile – even if it is the ‘default’ Profile. The Profile Management Tab displays your current wireless connection profile, and its details. You may add as many wireless profiles as you wish, by clicking **New**. You may even import and export your profile as a configuration file. This is handy if the laptop is to be used between two or more AP’s. There are two windows in the Profile Management Tab. The top window displays all profiles, with a green radio icon next to the active profile. The bottom window displays a brief summary of the configuration of the selected profile. Clicking **Modify** allows you to change the wireless connection configuration settings.

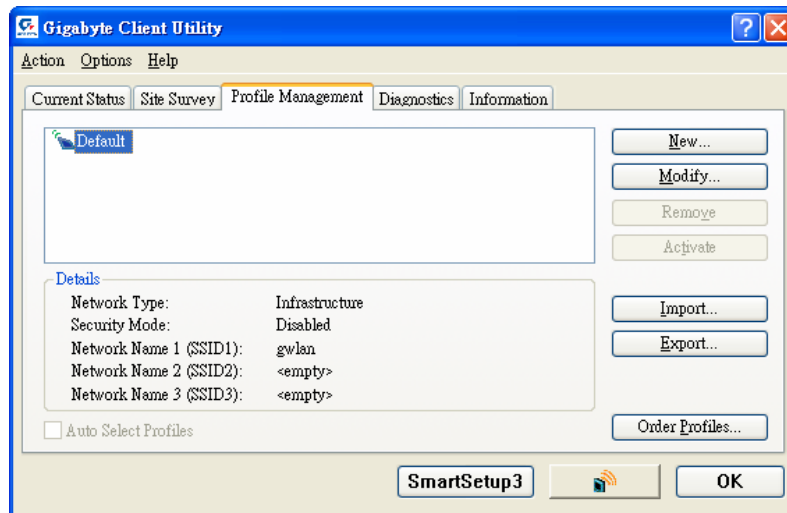

Figure 17. Profile Management Tab

**New** – Click to create a new profile.

**Modify** – Click to modify the selected profile.

**Remove** – Click to remove the selected profile

**Activate** – Click to activate the selected profile (and simultaneously de-activate the current profile)

**Import** – Import a profile configuration from file.

**Export** – Export a profile configuration to a file.

**Order Profiles** – Arranges the profiles in a list according to an order which is convenient to you.

**Radio**  - Toggle on or off the WP01GT wireless radio receiver.

### Profile Management > General Tab

---

Clicking **Modify** from the Profile Management Tab will present the Profile Management Dialogs. There are three tabs here: **General**, **Security**, and **Advanced Tab**.

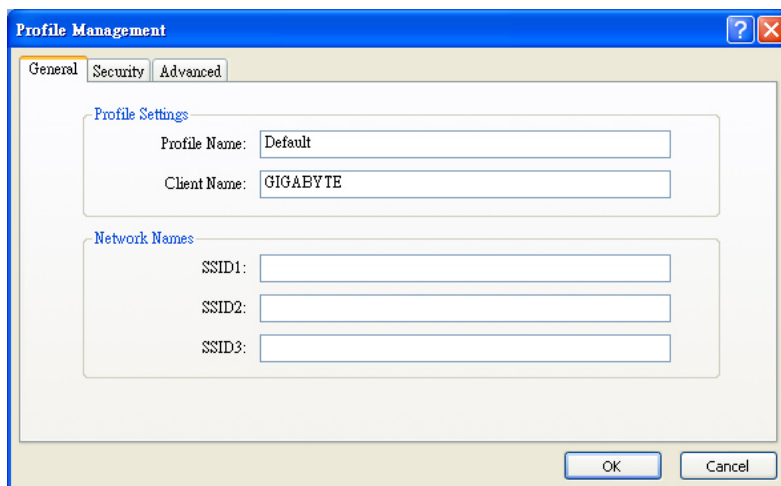

Figure 18. Profile Management > General Tab

**Profile Name** – A user defined, free form name for the new profile.

**Client Name** – The Desktop PC name. This field is automatically populated but can be edited as you wish.

**Network Names** – You may define up to three network names which this profile is used when connecting.

## Profile Management > Security Screen

The wireless security sub tab offers you the method of security (if any) you may select. Select WPA/WPA2, WPA/WPA2-Passphrase, 802.1x, Pre Shared WEP, or None. WPA/WPA2 is a security standard stronger than WEP encryption, and 802.1x is the RADIUS authentication service. The default setting is None.

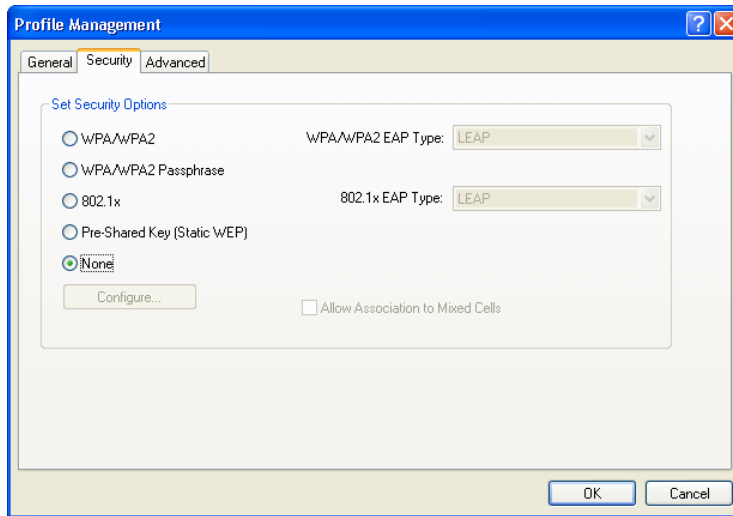

Figure 19. Profile Management > Security Tab

**Set Security Method – WPA/WPA2 – Wi-Fi Protected Access -** Choosing WPA opens the WPA/WPA2 EAP drop-down menu. The options include EAP-TLS, EAP-TTLS, PEAP(EAP-GTC), PEAP(EAP-MSCHAR V2), LEAP and EAP-FAST. Click on the Configure button and fill in the Define Certificate dialog.

**WPA/WPA2-Passphrase -** Enables WPA/WPA2-Pre Shared Key (PSK). Click on the Configure button and fill in the WPA/WPA2 Passphrase.

**802.1x – RADIUS Authentication.** Enables 802.1x security, and is only available if a RADIUS Server is connected to the router) Choosing 802.1x opens the 802.1x EAP type drop-down menu. The options include EAP-TLS, EAP-TTLS, PEAP(EAP-GTC), PEAP(EAP-MSCHAR V2), LEAP and EAP-FAST

**Pre-Shared Key -** Enables the use of pre-shared keys that are defined on both the access point and the station. To define pre-shared encryption keys, choose the Pre-Shared Key radio button and click the Configure button to fill in the Define Pre-Shared Keys window.

**Allow Associate to Mixed Cells –** Check the Allow Association to Mixed



Cells check box if the access point to which the client adapter is to associate (or the VLAN to which the client will be assigned) has WEP set to Optional and static WEP is enabled on the client adapter. Otherwise, the client is unable to establish a connection with the access point.

Uncheck the Allow Association to Mixed Cells check box if the access point to which the client adapter is to associate (or the VLAN to which the client will be assigned) does not have WEP set to Optional. This is the default setting.

**None** – no security is set. (Default setting)

Select the type of security encryption (WPA/WPA2, WPA/WPA2-Passphrase, WEP or RADIUS 802.1X) from the radio buttons, and click **Configure**. Depending on the security selected, the following Configure Security Screens will appear.

#### Configure Pre Shared Key (WEP) Security

To use WEP, select if you want Hex or ASCII method, enter a pre-shared key, select 64-bits, 128-bits, or 152-bits from the drop down box and click OK.

**Note:** ASCII text WEP keys are not supported on GIGABYTE Routers, you must choose the Hexadecimal (0-9,A-F) option if you are connecting with these Access Points.

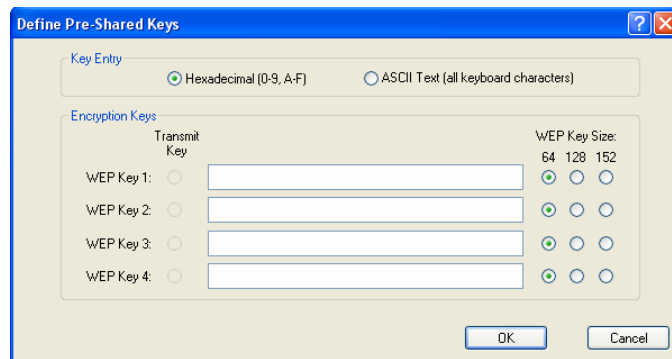

Figure 20. WEP key configuration

**WPA/WPA2-Passphrase** - When you select WPA/WPA2, the target 802.11 device must also be WPA/WPA2 enabled in order to communicate with each other. Obtain the WPA/WPA2 Passphrase for the access point from your system administrator and enter it in the WPA/WPA2 Passphrase field.

- WPA/WPA2 Passphrase must contain 8 to 63 ASCII text characters or 64 hexadecimal characters.
- Your client adapter's WPA/WPA2 Passphrase must match

the Passphrase used by the access point with which you are planning to communicate.

Click **OK** to save your changes and to return to the Profile Management window.

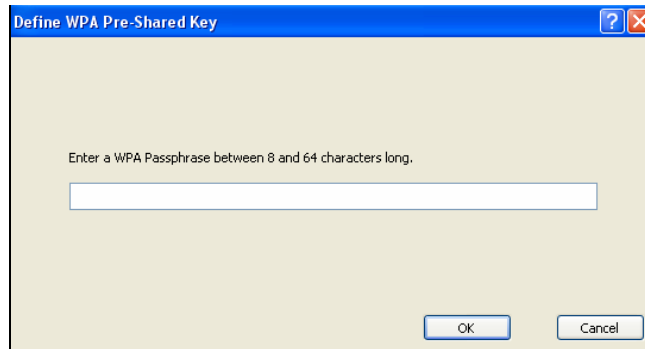

Figure 21. Enter WPA Passphrase

**Using LEAP** – Before you can enable LEAP authentication, your network access point must be configured for LEAP authentication. Perform one of the following from the Security Tab:

- If you want to enable LEAP without WPA/WPA2, choose 802.1x under Set Security Options and LEAP in the 802.1x EAP Type drop-down box.
- If you want to enable LEAP with WPA/WPA2, choose WPA/WPA2 under Set Security Options and LEAP in the WPA/WPA2 EAP Type drop-down box.

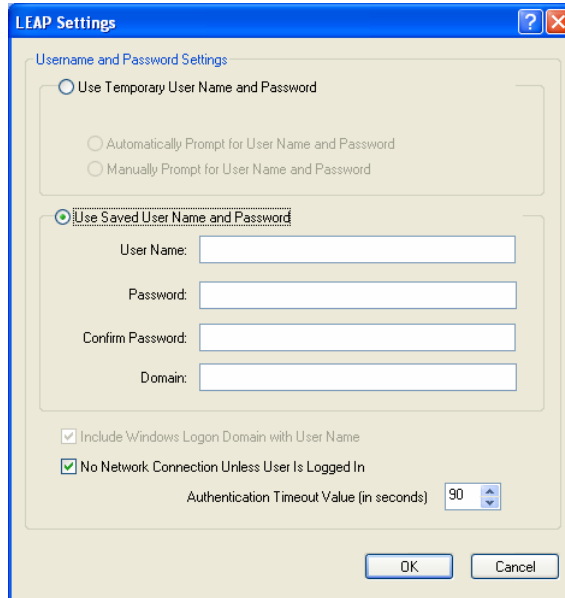

Figure 22. LEAP Settings

**Use Temporary User Name and Password** - Requires you to enter the LEAP username and password each time the computer reboots in order to authenticate and gain access to the network.

**Use Saved User Name and Password** - Does not require you to enter a LEAP username and password each time the computer reboots. Authentication occurs automatically as needed using a saved username and password (which are registered with the RADIUS server).

**User Name** – Enter a username

**Password/Confirm Password** – Enter a password in both fields

**Domain** - If you wish to specify a domain name that will be passed to the RADIUS server along with your username, enter it in the Domain field.

**Include Windows Logon Domain with User Name** - If you work in an environment with multiple domains and therefore want your Windows login domain to be passed to the RADIUS server along with your username

LEAP was proven to be susceptible to dictionary attacks, and EAP-FAST is preferable to LEAP. In short, EAP-FAST is hardened LEAP with better crypto protecting the challenge/response mechanism.

**Using EAP-FAST** – Before you can enable EAP-FAST authentication, your network access point must be configured for EAP-FAST authentication. Perform one of the following from the Security Tab:

- If you want to enable EAP-FAST without WPA/WPA2, choose 802.1x under Set Security Options and LEAP in the 802.1x EAP Type drop-down box.
- If you want to enable EAP-FAST with WPA/WPA2, choose WPA/WPA2 under Set Security Options and LEAP in the WPA/WPA2 EAP Type drop-down box.

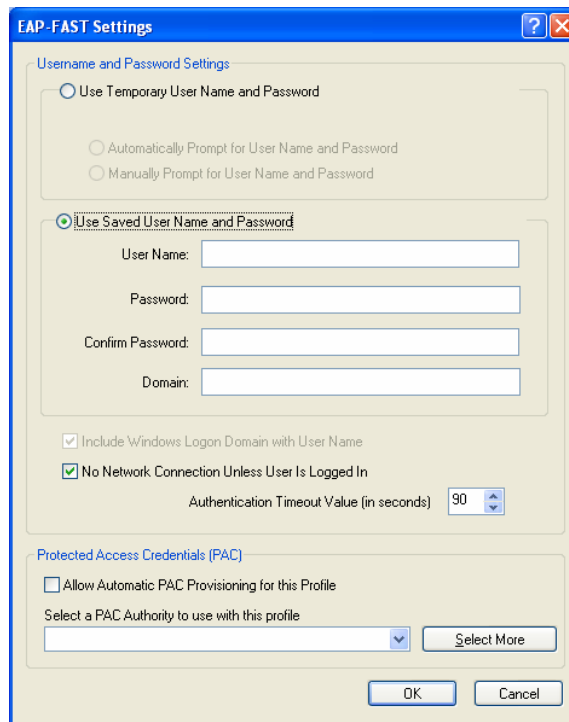

Figure 23. EAP-FAST Settings

**Use Temporary User Name and Password** - Requires you to enter the EAP-FAST username and password each time the computer reboots in order to authenticate and gain access to the network.

**Use Saved User Name and Password** - Does not require you to enter an EAP-FAST username and password each time the computer reboots. Authentication occurs automatically as needed using a saved username and password (which are registered with the RADIUS server).

**User Name** – Enter a username

**Password/Confirm Password** – Enter a password in both fields

**Domain** -- If you wish to specify a domain name that will be passed to the RADIUS server along with your username, enter it in the Domain field.

**Include Windows Logon Domain with User Name** -- If you work in an environment with multiple domains and therefore want your Windows login domain to be passed to the RADIUS server along with your username

**Select the protected access credential (PAC) authority provisioning**

- Check the **Allow Automatic PAC Provisioning for this Profile** checkbox to have the system automatically provide the PAC for this profile.
- OR. To set a PAC authority, choose a PAC Authority from the drop-down list to use. Click the **Select More** button to import or delete a new PAC authority

### Using EAP-TLS, EAP-TTLS or PEAP

Before you can enable EAP-TLS, EAP-TTLS or PEAP authentication, our network devices must meet the following requirements:

- You must have a valid Windows username and password, and the password cannot be blank.
- The appropriate certificates must be installed on your computer. EAP-TLS requires both a Certificate Authority (CA) certificate and a user certificate while EAP-TTLS or PEAP requires only a CA certificate.

If you want to enable **EAP-TLS without WPA/WPA2**, choose 802.1x under Set Security Options and EAP-TLS in the 802.1x EAP Type drop-down box. If you want to enable **EAP-TLS with WPA/WPA2**, choose WPA/WPA2 under Set Security Options and EAP-TLS in the WPA/WPA2 EAP Type drop-down box.

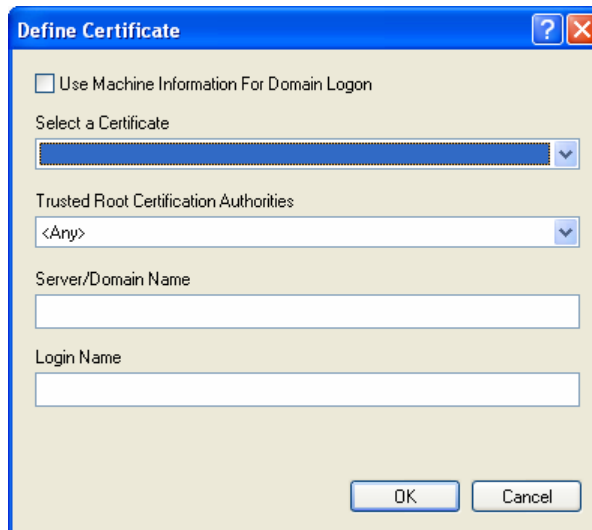

Figure 24 - Define Certificate Window

**Select a Certificate** – Choose a certificate from the dropdown list.

**Trusted Root Certification Authorities** – Choose an authority from the dropdown list.

**Server/Domain Name** - Leave the Server/Domain Name field blank to allow the client to accept a certificate from any server that supplies a certificate signed by the certificate authority listed in the Server Properties drop-down list.

**Login Name** - If the Login Name field is not filled in automatically, enter your username in this format: username@domain.com

### Enabling EAP-TTLS

If you want to enable EAP-TTLS **without WPA/WPA2**, choose **802.1x** under Set Security Options and EAP-TTLS in the 802.1x EAP Type drop-down box.

If you want to enable EAP-TTLS **with WPA/WPA2**, choose **WPA/WPA2** under Set Security Options and EAP-TTLS in the WPA/WPA2 EAP Type drop-down box.

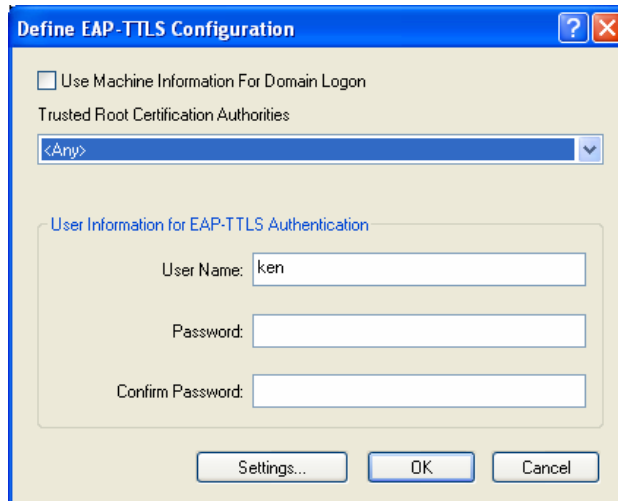

Figure 25 - Define EAP-TTLS Certificate Window

**Trusted Root certification Authorities** – Choose the certificate authority from which the server certificate was downloaded in the drop-down list.

**User information for EAP-TTLS Authentication** - Enter your EAP-TTLS username and password in the corresponding fields.

### Enabling PEAP (EAP-GTC)

If you want to enable PEAP (EAP-GTC) **without WPA/WPA2**, choose **802.1x** under Set Security Options and PEAP (EAP-GTC) in the 802.1x EAP Type drop-down box.

If you want to enable PEAP (EAP-GTC) **with WPA/WPA2**, choose **WPA/WPA2** under Set Security Options and PEAP (EAP-GTC) in the WPA/WPA2 EAP Type drop-down box.

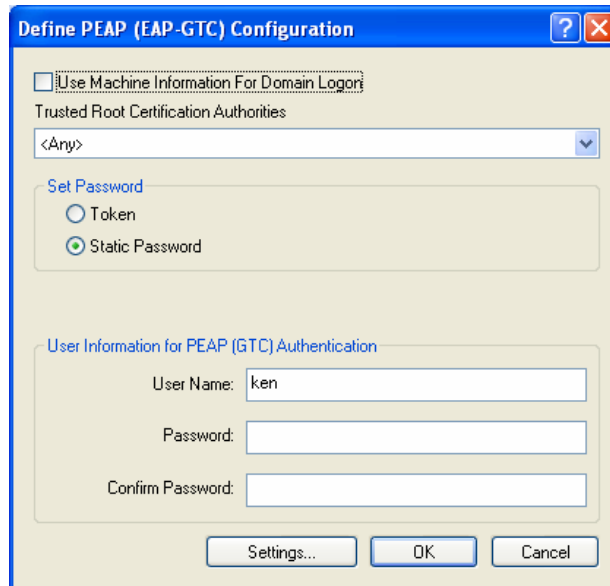

Figure 26 - Define PEAP Certificate Window

**Trusted Root Certification Authorities** – Choose the certificate authority from which the server certificate was downloaded in the drop-down list.

**Set Password** – Select Token or Static Password, depending on your users database.

**User information for PEAP (GTC) Authentication** - Enter your PEAP username and password in the corresponding fields.

### Enabling PEAP (EAP MSCHAP V2)

If you want to enable PEAP (EAP-MSCHAP V2) without WPA/WPA2, choose 802.1x under Set Security Options and PEAP (EAP-MSCHAP V2) in the 802.1x EAP Type drop-down box.

If you want to enable PEAP (EAP-MSCHAP V2) with WPA/WPA2, choose WPA/WPA2 under Set Security Options and PEAP (EAP-MSCHAP V2) in the WPA/WPA2 EAP Type drop-down box.



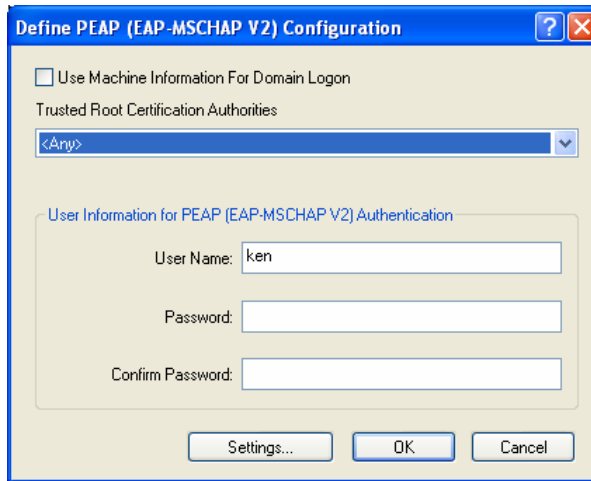

Figure 27 - Define EAP Server Window

**Trusted Root Certification Authorities** – Choose the certificate authority from which the server certificate was downloaded in the drop-down list.

**User information for PEAP (EAP-MSCHAP V2) Authentication** - Enter your PEAP username and password in the corresponding fields.

### Profile Management > Advanced Screen

The Profile Management (Advanced) window (see Figure 28) enables you to set parameters that control how the client adapter operates within an infrastructure or ad hoc network. To open this window, click the **Advanced** tab from any Profile Management window.

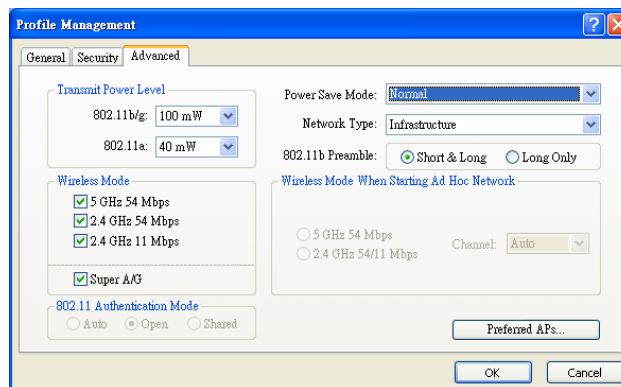

Figure 28 – Advanced Profile Management

**Transmit Power Level** - Specifies the preferred power level at which your client adapter transmits. Although the adapter supports up to 100 mW, the transmit power level that is actually used is limited to the maximum value allowed by your country's regulatory agency (FCC in the U.S., DOC in Canada, ETSI in Europe, TELEC in Japan, etc.).

Reducing the transmit power level conserves battery power but decreases radio range.

**Power Save Mode** - Sets your client adapter to its optimum power consumption setting.

CAM (Constantly Awake Mode), Fast PSP (Power Save Mode), or Max PSP (Max Power Saving) Default: CAM (Constantly Awake Mode)

**Network Type** - Specifies the type of network in which your client adapter is installed.

Default: Infrastructure

**802.11b Preamble** - Determines whether your client adapter uses both short and long radio headers or only long radio headers.

**Wireless Mode** - Specifies the frequency and rate at which your client adapter should transmit packets to or receive packets from access points.

**Wireless Mode when starting Ad hoc network** - Specifies the frequency and rate at which your client adapter should transmit packets to or receive packets from other clients (in ad hoc mode).

**Channel** - Specifies the channel that your client adapter uses for communications in a 2.4-GHz ad hoc network. The available channels conform to the IEEE 802.11 Standard for your regulatory domain.

The channel of the client adapter must be set to match the channel used by the other clients in the wireless network.

**802.11 Authentication Mode** - Specifies how your client adapter attempts to authenticate to an access point. Open and shared authentication do not rely on a RADIUS server on your network.

### **Preferred Access Points**

If this profile is configured for use in an infrastructure network and you want to specify up to four access points to which the client adapter should attempt to

associate, click Preferred APs. The Preferred Access Points window appears

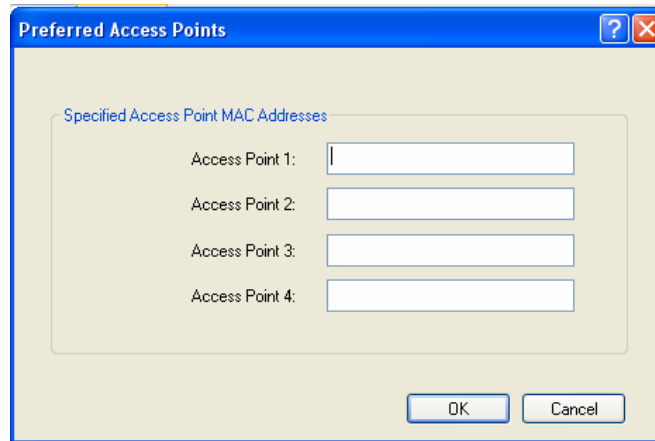

Figure 29 – Specify MAC Access Points

Leave the Access Point 1 through Access Point 4 fields blank or enter the MAC addresses of up to four preferred access points to which the client adapter can associate; then click OK. (The MAC address should consist of 12 hexadecimal characters.) If the specified access points are not found or the client adapter roams out of range, the adapter may associate to another access point.

Go to the next section to set additional parameters or click OK to save your changes and return to the Profile Management window.

## Diagnostics Tab

---

Basic transmit and receive statistics are available here (Figure 30), with more advanced statistics available from the **Advanced Statistics** button.

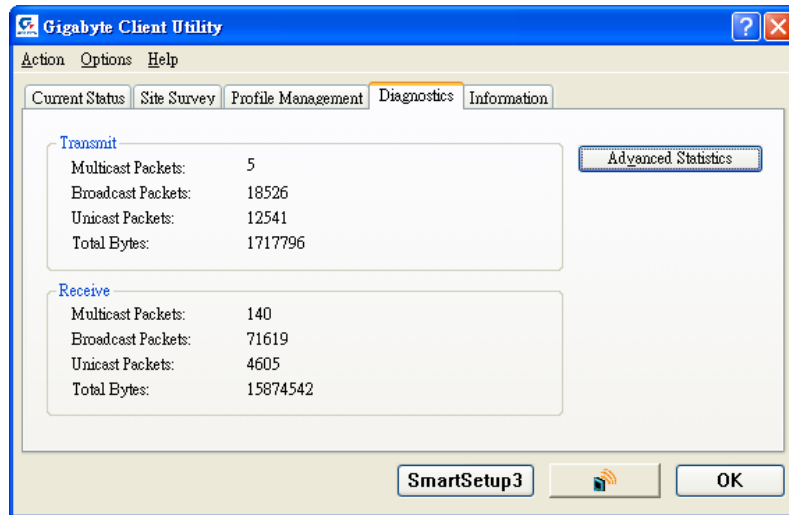

Figure 30 – Diagnostics Tab

#### Transmit:

**Multicast Packets** – Number of packets sent to a multicast address

**Broadcast Packets** – Number of packets sent to a broadcast address

**Unicast Packets** – Number of packets sent to a unicast address

**Total Bytes** – Total bytes transmitted

#### Receive:

**Multicast Packets** – Number of packets received as a multicast address

**Broadcast Packets** – Number of packets received as a broadcast address

**Unicast Packets** – Number of packets received as a unicast address

**Total Bytes** – Total bytes received

### Advanced Statistics

More advanced statistics about your network are available in the Advanced Statistics window (Figure 31).

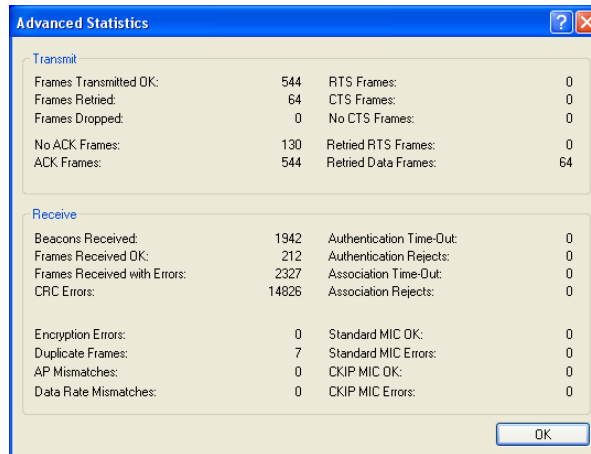

Figure 31. Advanced Statistics

### Transmit

**Frames Transmitted OK** – The number of total frames transmitted or received without errors.

**Frames received** – The number of frames receive by the client.

**Frames Dropped** – The number of frames dropped by the client.

**No ACK Frames** – Frames which were not acknowledged by the client.

**ACK Frames** – Frames acknowledged by the client.

**RTS Frames** – Request to Send, Client sends RTS frame to AP.

**CTS Frames** – Clear to Send. Client receives CTS frame from AP.

### Receive

**Beacons Received** – Beacon packets received.

**Frames Received OK** – The number of frames received without errors.

**Frames Received with Errors** – The number of frames not received due to errors.

**Duplicate Frames** – Number of duplicate frames received

**AP Mismatches** – MAC address/public key combination mismatches.

Sometimes indicative of hacking/spoofing.

**Data Rate Mismatches** - The number of times the client adapter tried to associate to an access point but was unable to because the adapter's data rate was not supported by the access point.

**Authentication Time-Out** - The number of times the client adapter tried to authenticate to an access point but was unable to because the access point did not respond fast enough (timed out).

**Authentication Rejects** - The number of times the client adapter tried to authenticate to an access point but was rejected.

**Association Time-Out** - The number of times the client adapter tried to associate to an access point but was unable to because the access point did not respond fast enough (timed out).

**Association Rejects** - The number of times the client adapter tried to associate to an access point but was rejected.

**Standard MIC OK** - The number of frames that were received with the correct message integrity check (MIC) value.

**Standard MIC Errors** - The number of frames that were discarded due to an incorrect message integrity check (MIC) value.

**CKIP MIC OK** - The number of frames that were received with the correct message integrity check (MIC) value when CKIP was being used.

**CKIP MIC Errors** - The number of frames that were discarded due to an incorrect message integrity check (MIC) value when CKIP was being used.

## Adapter Information Tab

---

The Driver Info Tab displays the information of the card's driver, MAC address and version date.

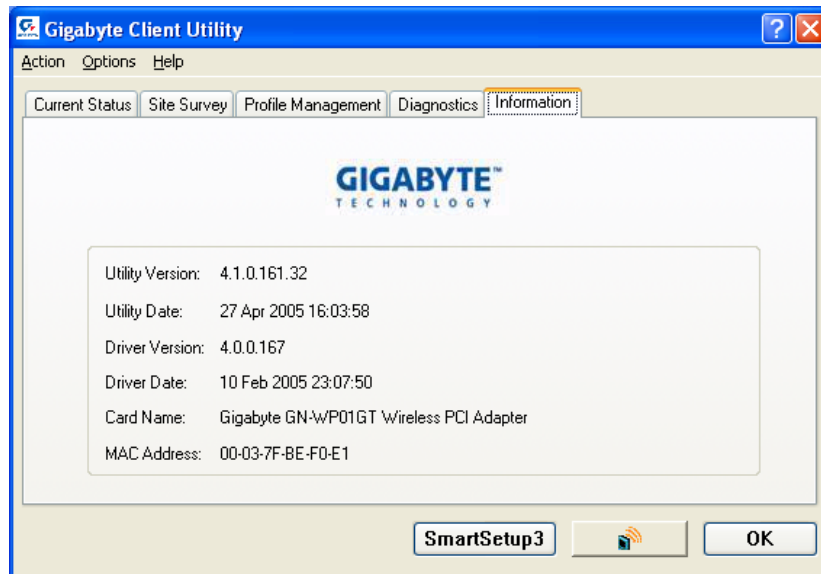

Figure 31. Adapter Info Tab

**Utility Version** -- The version number of the WP01GT utility.

**Utility Date** -- The date of manufacture of the WP01GT utility file.

**Driver Version** -- The version number of the WP01GT driver.

**Driver Date** -- The date of manufacture of the WP01GT driver file.

**Card Name** -- The Make and Model name of the wireless Adapter.

**MAC Address** -- The MAC address of the WP01GT.

## Appendix A

### FAQ

This section provides solutions to common problems that may occur during installation, configuration or use of the Adapter.

**Q: What is Ad-hoc mode?**

**A:** When a wireless network is set to Ad-hoc mode, the wireless-equipped computers are configured to communicate directly with each other. The Ad-hoc wireless network will not communicate with any wired network..

**Q: What is Infrastructure mode?**

**A:** Also referred to as Access Point Mode. When a wireless network is set to infrastructure mode, the wireless network is configured to communicate with a wired network through a wireless access point.

**Q: What is the IEEE 802.11g standard?**

**A:** The IEEE 802.11g standard specifies data rates of up to 54 Mbps in the 2.4-GHz band. It uses Orthogonal Frequency Division Multiplexing (OFDM), which is provided by this standard and is compatible with 802.11b standard offering speeds of about 11 Mbps. This standard uses Complementary Code Keying (CCK) modulation. Both 11g and 11b can operate at a range of up to 300 feet.



## Appendix B Wireless Security

The WP01GT, and all of GIGABYTE's wireless offerings are all built to deliver the easiest and most secure wireless networking experience as possible. Please understand the following key points in order to enjoy a safe and secure wireless network.

### Wireless Security Tips

The following are basic wireless security tips which will minimize the chance of a breach in your private wireless network:

1. Change the default SSID.
2. Disable SSID Broadcast.
3. Change the default password for the Administrator account.
4. Enable MAC Address Filtering.
5. Change the SSID periodically.
6. Use the highest encryption algorithm possible. Use WPA if it is available.
7. Change the WEP encryption keys periodically.

### Don't Be a Statistic

Wireless networks are easy to find. Statistics show that roughly half of all wireless networks have no security in place at all, i.e. they are open systems for anyone to freely use as they please. In fact, nearly 25% of the time, the default administrator username/password remain as system defaults! Leaving your wireless network open for the taking. Following the easy steps outlined above will give you peace of mind, and keep your network out of reach from would be hackers. Don't be a statistic!

## Appendix C Troubleshooting

**Problem 1:      The WP01GT does not work correctly.**

Response :

- Try removing and re-inserting the Adapter. Make sure that the WP01GT is FIRMLY seated into the PCI slot.
- Uninstall the driver software from your PC, and try reinstalling.
- Try rebooting your PC.

**Problem 2:      I cannot communicate with other computers in Access Point (infrastructure) Mode.**

Response:

- Assure that the Desktop PC is powered on.
- Assure that the WP01GT is configured with the same SSID and WEP settings as other computers in the Access Point configuration.

## Appendix D Glossary

### **ADSL**

Asymmetric digital subscriber line (ADSL) is a new modem technology that converts existing twisted-pair telephone lines into access paths for high-speed communication of various sorts.

### **Auto-MDI/MDIX**

On a network hub or switch, an auto-MDI/MDIX port automatically senses if it needs to act as a MDI or MDIX port. The auto- MDI/MDIX capability eliminates the need for crossover cables.

### **Auto-negotiate**

To automatically determine the correct setting. The term is often used with communications and networking

### **DHCP**

The Dynamic Host Configuration Protocol (DHCP) is an Internet protocol for automating the configuration of computers that use TCP/IP. DHCP can be used to automatically assign IP addresses, to deliver TCP/IP stack configuration parameters such as the subnet mask and default router, and to provide other configuration information such as the addresses for printer, time and news servers.

### **DMZ**

In computer networks, a DMZ (demilitarized zone) is a computer host or small network inserted as a "neutral zone" between a company's private network and the outside public network. It prevents outside users from getting direct access to a server that stores company data. Typically, the DMZ contains devices accessible to Internet traffic, such as Web (HTTP) servers, FTP servers, SMTP (e-mail) servers and DNS servers.

### **DNS**

The Domain Name System (DNS) is a distributed Internet directory service. DNS is used mostly to translate between domain names and IP addresses, and to control Internet email delivery. Most Internet services rely on DNS to work. If DNS fails, web sites cannot be located and email delivery service will be suspended.

### **Dynamic IP Address**

An IP address is automatically assigned to a user's AP in a TCP/IP network typically by a DHCP server.

**Firewall**

A system designed to prevent unauthorized access to or from a private network. Firewalls can be implemented in both hardware and software, or a combination of both. Firewalls are frequently used to prevent unauthorized Internet users from accessing private networks connected to the Internet, especially intranets. All messages entering or leaving the intranet pass through the firewall, which examines each message and blocks those that do not meet the specified security criteria.

**Gateway**

A device, usually a Router, that connects hosts on a local network to other networks.

**IP Address**

Every PC on the Internet has a unique identifying number, called an IP Address. A typical IP address looks like this: 216.27.61.137

**IPSec**

IPSec stands for IP Security. It provides authentication and encryption over the Internet. It functions at Layer 3 and thus secures everything on the network. It has become a standard protocol used for virtual private networks (VPNs).

**MAC Address**

On a local area network (LAN) or other network, the MAC (Media Access Control) address is your computer's unique hardware number. Usually written as: 01:23:45:67:89:ab

**MTU**

The size in bytes of the largest packet that can be sent or received.

**NAT**

A technique by which several hosts share a single IP address for accessing to the Internet.

**Ping (Packet Internet Groper)**

A utility to determine whether a specific IP address is accessible. It works by sending a packet to the specified address and waiting for a reply. PING is used primarily to troubleshoot Internet connections.

**SSID**

SSID is the name representing the Router in WLAN.

**PPPoE**

Point-to-Point over Ethernet is a protocol for connecting remote hosts to the Internet over an always-on connection by simulating a dial-up connection.

**Router**

A device that forwards data packets along networks. A router is connected to at least two networks, commonly two LANs or WANs or a LAN and its ISP network. Routers are located at gateways, the places where two or more networks connect.

**Subnet Mask**

A mask used to determine which subnet an IP address belongs to. An IP address has two components, the network address and the host address. Subnetting enables the network administrator to further divide the host part of the address into two or more subnets.

**TCP/IP**

TCP/IP (Transmission Control Protocol/Internet Protocol), the suite of communications protocols used to connect hosts on the Internet.

**VPN**

Virtual private networks are secured private network connections, built on top of publicly accessible infrastructure, such as the Internet or the public telephone network. VPNs typically employ some combination of encryption, digital certificates, strong user authentication and access control to provide security to the traffic they carry. They usually provide connectivity to many machines behind a gateway or firewall.

**WAN**

Wide Area Network, a communication network that covers a relatively broad geographic area, consisting of two or more LANs. Broadband communication over the WAN is often through public networks such as the ADSL or Cable systems, or through leased lines or satellites. To simplify it, please image network as a WAN.

**WEP**

WEP (Wired Equivalent Privacy) is a data privacy mechanism based on a 64/128-bit shared key algorithm, as described in the IEEE 802.11 standard.

## Appendix E Specifications

<b>1. System</b>	
Host Interface	PCI 2.3
Operating Voltage	3.3VDC $\pm$ 5%
<b>2. RF Performance</b>	
<b>802.11b</b>	
Frequency Band	2412 ~ 2484 MHz (subject to local regulation)
Modulation Technology	DSSS (Direct Sequence Spread Spectrum)
Modulation Techniques	CCK, DQPSK, DBPSK
Date Rates	11, 5.5, 2, 1Mbps, auto fallback
Typical Power Consumption	Doze: 25mA Receive: 250mA Transmit: 560mA
Peak Output Power	21dBm @ Nominal Temp Range
Minimum Receive Sensitivity	-85dBm @ 11 Mbps, Nominal Temp Range
Antenna	External antenna with the gain of 2dBi, L type
<b>802.11g(backward compatible to 802.11b)</b>	
Frequency Bands	2412-2484 MHz (subject to local regulations)
Modulation Technology	OFDM and DSSS
Modulation Techniques	64QAM, 16QAM, QPSK, BPSK, CCK, DQPSK, DBPSK
Date Rates	Base mode: 54, 48, 36, 24, 18,12, 9, 11, 6, 5.5, 2, and 1 Mbps, auto fallback Turbo mode: 108, 96, 72, 48, 36, 24, 18 and 12 Mbps auto fallback
Typical Power Consumption	Doze: 25mA Receive: 250 mA Transmit: 530 mA
Peak Output Power	20dBm @ Nominal Temp Range
Receive sensitivity	Minimum -72dBm; typical -74dBm @54Mbps, Nominal Temp Range
Antenna	External antenna with the gain of 2dBi, L type

Super G Wireless PCI Adapter

3.Safety Regulation and Operating Environment		
EMC certification	FCC Part 15 (USA)	DGT (Taiwan)
	CE (Europe)	
Temperature Range	Operating: 0 ~ 55 deg C, Storing: -20 ~ 65 deg C	
Humidity	Max. 90% Non-condensing	
4. Software Support		
Driver	Windows 2000/XP	
Security	WPA; AES; 802.1X client for Windows XP; 64/128/152 bit WEP	
Roaming	Seamless roaming among 802.11b/g access points.	
Management Utility	Monitors the network situation.	
5. Mechanical		
Dimensions	120mm*121mm*20mm (120mm*81mm*20mm)	
Weight	52.5(48.5)± 1 g	
Packaging	Packaging specially used by Gigabyte.	

**\* Subject to Change without Notices**

# Appendix F

## Regulatory Information

**CE Mark Warning:** This is a Class B product. In a domestic environment, this product may cause radio interference, in which case the user may be required to take adequate measures.

**FCC Statement:** This equipment has been tested and found to comply with the limits for a Class B digital device, pursuant to Part 15 of the FCC Rules. These limits are designed to provide reasonable protection against harmful interference in a residential installation. This equipment generates, uses and can radiate radio frequency energy and, if not installed and used in accordance with the instructions, may cause harmful interference to radio communications. However, there is no guarantee that interference will not occur in a particular installation. If this equipment does cause harmful interference to radio or television reception, which can be determined by turning the equipment off and on, the user is encouraged to try to correct the interference by one of the following measures:

- Reorient or relocate the receiving antenna.
- Increase the separation between the equipment and receiver.
- Connect the equipment into an outlet on a circuit different from that to which the receiver is connected.
- Consult the dealer or an experienced radio/TV technician for help.

FCC Caution: To assure continued compliance, any changes or modifications not expressly approved by the party responsible for compliance could void the user authority to operate this equipment.

This device complies with Part 15 of the FCC Rules. Operation is subject to the following two conditions: (1) This device may not cause harmful interference, and (2) this device must accept any interference received, including interference that may cause undesired operation.

### IMPORTANT NOTE:

#### FCC Radiation Exposure Statement:

This equipment complies with FCC radiation exposure limits set forth for an uncontrolled environment. This equipment should be installed and operated with minimum distance 20cm between the radiator & your body. The antenna(s) used for this transmitter must not be co-located or operating in conjunction with any other antenna or transmitter.

### Europe - Declaration of Conformity

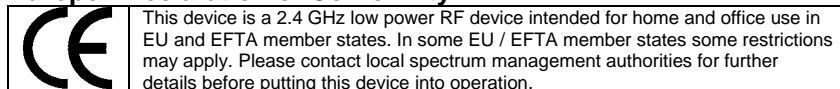

GIGA-BYTE Technology, Inc. declares that the product: **Wireless Broadband Router Model Number: GN-B49G** is in conformity with and in accordance with the European Directive of EMC, 89/336 EEC for the following sections:

EN 61000-3-2, EN 61000-3-3, EN 55024, and EN 55022 Disturbances and Immunities

GIGA-BYTE Technology, Inc. also declares the conformity of above mentioned product with the actual required safety standards in accordance with LVD Directive 73/23 EEC:

EN 60950 Safety

In accordance with R&TTE Directive 1995/5/EC, Part 17: Requirements for Operation in the European Community, GIGA-BYTE Technology, Inc declares the conformity of the above mentioned products for:



## Super G Wireless PCI Adapter

EN 300 328-2 V1.2.1, ETSI EN 300 328-1 : V1.3.1, EN 301 489-1, and EN 301 489-17 Technical Requirements for Radio Equipment

### **Countries of Operation and Conditions of Use in the European Community**

The user should run the configuration utility program provided with this product to check the current channel of operation and confirm that the device is operating in conformance with the spectrum usage rules for European Community countries as described in this section. European standards dictate a maximum radiated transmit power of 100mW EIRP and a frequency range of 2.400 - 2.4835 Ghz.

**Trademarks:** GIGABYTE is a registered trademark of GIGA-BYTE Technology, Inc. Other trademarks or registered trademarks are the property of their respective manufacturers or owners.

**Copyright Statement:** No part of this publication or documentation accompanying this Product may be reproduced in any form or by any means or used to make any derivative such as translation, transformation, or adaptation without permission from GIGABYTE/GIGA-BYTE Technology, Inc., as stipulated by the United States Copyright Act of 1976. Contents are subject to change without prior notice. **Copyright© 2004 by GIGA-BYTE Technology, Inc. All rights reserved.**

## Appendix G Warranty

### **Limited Warranty Statement (1-Year Warranty)**

Thank you for purchasing the GIGABYTE Product. This limited warranty statement will provide you one year warranty starting from the purchase date. Of which if any defect is occurred due to accidents or any man-made factors, or any unauthorized torn-off or damage to GIGABYTE's sticker on the product, GIGABYTE Technology will not provide after-sale services, such as:

- Products are damaged due to any violation of instructions on user manual.
- Hardware is damaged due to inappropriate assembling.
- Products are damaged due to the use of illegal accessory.
- Products are damaged due to parts disassembling without authorization.
- Products are damaged due to exceeding environment limits.
- Products are damaged due to unexpected external force.
- Products are damaged due to nature disasters.
- Products are copies or illegally smuggled goods.

### **PLEASE RECORD THE FOLLOWING INFORMATION REGARDING YOUR WARRANTY**

<b>Name of Customer:</b>	
<b>Phone No:</b>	
<b>Address:</b>	
<b>Email:</b>	
<b>Model:</b>	
<b>Serial:</b>	
<b>Date of Purchase:</b>	
<b>Place of Purchase:</b>	
<b>From Whom:</b>	
<b>Distributor:</b>	

### **Customer Service**

<p><b><u>GIGA-BYTE TECHNOLOGY CO., LTD.</u></b> No.6, Bau Chiang Road, Hsin-Tien, Taipei Hsien, Taiwan Toll Free 0800-079-666 Tel: 886-2-8665-2665 Fax:886-2-89124007 <a href="http://www.gigabyte.com.tw">http://www.gigabyte.com.tw</a></p>
---