

Owner's Manual

Serial Number:

Model Number: **CBQ-120-ELE/
CBQ-120-ELEM**

PowerChef[®]
CONVERTIBLE

PowerChef Convertible Electric Grill CBQ-120-ELE CBQ-120-ELEM

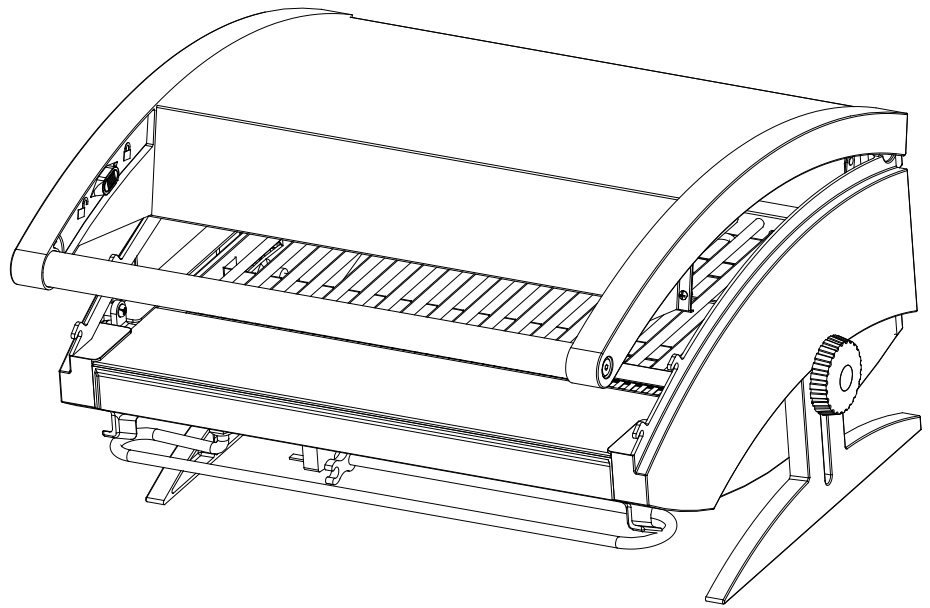

7209640100REV02

Dimplex North America Limited
1367 Industrial Road • Cambridge ON Canada N1R 7G8

1-800-668-6663 • www.dimplex.com

PowerChef Convertible Features

Welcome and Thank You for purchasing a Dimplex PowerChef Convertible Electric Grill.

The following introduction highlights the many features of the PowerChef Convertible grill. Detailed operating instructions are contained later on in this manual.

EvenSear™ Cooking System

At the heart of your PowerChef Convertible grill is the EvenSear™ Cooking System. The dual layer grill system functions in two ways. The top grill sears your food, with direct contact, and at the same time your food is cooked gently and evenly by additional radiant heat from the lower element. The EvenSear™ system ensures that all energy supplied to the grill is directly used on cooking your food to perfection. The EvenSear™ Cooking System applies energy evenly and consistently throughout the entire grill area, eliminating “cool spots”.

Portable and Convertible

The PowerChef Convertible features a locking lid design that allows the lid bar to serve as the carrying handle should you choose to move the grill or take it with you. In addition, a range of optional accessories are available that allow the standard tabletop unit to be used on a freestanding pedestal or as a permanent wall-mount installation. Side shelves are also available for either the pedestal or wall-mount configurations.

No Combustion or Tanks

PowerChef Convertible grill utilizes your standard household electric current and provides a safe source of heat to cook your food. The PowerChef Convertible grill, with no open flame or combustion, heats up quickly, and never needs refueling! No gas or other fuel fumes will impart unwanted tastes or odor to your food.

Easy to Clean

With its stainless steel upper grill, the EvenSear™ Cooking System is easy to keep clean.

100% Usable Grill Surface

Because there are no variations in temperature or performance, the EvenSear™ Cooking System provides 100% use of its grill area. The full 216 square inch grill maintains a consistent even temperature, even in the corners!

Advanced Control System

The PowerChef Convertible provides precision cooking control in your choice of either MANUAL or PROGRAM modes.

Program Cooking

The PowerChef Convertible advanced cooking technology panel provide precision control for a wide choice of foods, assuring they are cooked to perfection. The control panel prompts you through easy steps to program the type of food and how well you like it cooked. Once programmed, the PowerChef Convertible grill prompts you when it is time to start cooking, when it is time to turn your food over and when it is done! Audible signals alert you to each step! If you miss a signal, the PowerChef Convertible grill automatically reduces the heat to a minimum heat setting to avoid overcooking.

Manual Cooking

If pre-programmed cooking options don't suit your taste, you can of course prepare food your way using the manual mode.

Lid Down Cooking

To conserve energy and reduce cooking time, we recommend that the PowerChef Convertible be used with the lid down during cooking. A thermometer, featured in many other grills, which reads only the air temperature inside the cabinet, is unnecessary on the PowerChef Convertible. The EvenSear™ Cooking System relies and utilizes direct cooking rather than air temperature to cook your food.

Versatile

With no open flame, no combustion and no need to refuel the PowerChef Convertible grill can be used safely in many areas that other grills cannot.

Electrical Requirements



A Ground Fault Interrupt (GFI) outdoor outlet or a circuit protected by a ground fault breaker with a rating of 15 Amps, 120 Volts is strongly recommended. A dedicated circuit is preferred but not essential in all cases. A dedicated circuit will be required if, after installation, the circuit breaker trips or the fuse blows on a regular basis when the electric grill is operating. Additional appliances on the same circuit may exceed the current rating of the circuit breaker.

Contents

Important Instructions.....	Page 1
Model and Serial Number Information	Page 2
Site Selection and Installation	Page 2
Guide to your new CBQ Convertible Electric Grill.....	Page 4
Control Panel Operating Guide	Page 4
Advanced Features	Page 5
Operation Manual Mode.....	Page 6
Operation Program Mode.....	Page 7
Care and Cleaning	Page 9
Warranty.....	Page 10

IMPORTANT INSTRUCTIONS

Please Save This User's Manual For Future Reference

- ! **NOTE:** Procedures and techniques that are considered important enough to emphasize.
 -  **CAUTION:** Procedures and techniques which, if not carefully followed, will result in damage to the equipment.
 -  **WARNING:** Procedures and techniques which, if not carefully followed, will expose the user to the risk of fire, serious injury, illness or death.
 -  **WARNING:** Read all instructions and warning labels prior to use. Failure to follow these safeguards may result in serious personal injury or property loss. This appliance is intended for outdoor household, non-commercial use only.
1. **WARNING:** Do not use charcoal, or any other combustible material in an electric grill.
 2. Never touch hot surfaces, use handles or knobs. The temperature of accessible metal surfaces may be high when the appliance is operating. Use cooking tongs, gloves, or cooking mitts at all times since the grill will become very hot. Open hood carefully when cooking to avoid burns from the hot air and steam trapped inside.
 3. Wear clothing that does not have hanging shirt tails, frills, or apron strings.
 4. Use long-handle barbeque utensils to avoid personal injury caused by burns and splatters.
 5. To protect against electric shock, never immerse cord, plugs or electric heating element in water or any other liquid.
 6. Never leave the electric grill on when you are not cooking.
 7. Never operate any appliance with damaged electrical components or after the appliance has malfunctioned. Regularly inspect supply cord and connections. If cord, element or control is damaged or worn, it must be replaced by an authorized service facility as special tools are required. Do not attempt to repair the appliance yourself. Contact your authorized service agent for installation of electrical replacement kit.
 8. The use of non Dimplex accessory attachments is not recommended and may cause damage to the unit or injury.
 9. Never let cord touch hot surfaces.
 10. To avoid personal injury, lock and close hood before moving.
 11. Never move a hot grill or leave it unattended.
 12. Never move an electric grill unless it is unplugged.
 13. Never use an electric grill in the rain, sleet or snow.
 14. Never use an electric grill near combustible or flammable materials.
 15. Turn the power off on the electric grill before unplugging.
 16. The use of longer detachable power supply cords or extension cords is not recommended. Extension cords may overheat and cause a risk of fire. If you must use an extension cord, it must be intended for outdoor use and have a rating of no less than 1875 Watts. Outdoor extension cords are marked with the suffix letters "W-A" and have a tag stating "Suitable for Use with Outdoor Appliances".
 17. Store the electric grill out of reach of children.
 18. Never allow other persons to be near the electric grill while in use.
 19. Do not use the electric grill or its accessories for anything other than the intended use.
 20. Always check that food is fully cooked before consumption.
 21. Do not attempt to remove the cooking grid from the unit.
 22. This appliance is not intended for use by persons (including children) with reduced physical, sensory or mental capabilities or lack of experience and knowledge, unless they have been given supervision concerning use of the appliance by a person responsible for their safety. Children should be supervised to ensure that they do not play with the appliance.
 23. This appliance is not to be operated by means of an external timer or separated remote control device.
 24. Turn off the grill and wait until it is cool to the touch (approximately 30 minutes) before moving, covering or storing. Unplug the electric grill from outlet when not in use or before cleaning. Allow grill to cool before cleaning or adding or removing parts. Do not clean this product with high pressure hoses.
 25. Store products indoors when not in use - out of the reach of children.
 26. Do not clean this product with a water spray or the like.

SAVE THESE INSTRUCTIONS

PowerChef Convertible Model And Serial Number Information

If you have any questions regarding this product please have the model and serial numbers available upon calling customer service or technical support. To locate the model and serial number labels see Figure 1 and 2 below. Record the model number, serial number, on the front cover of this manual for future reference.

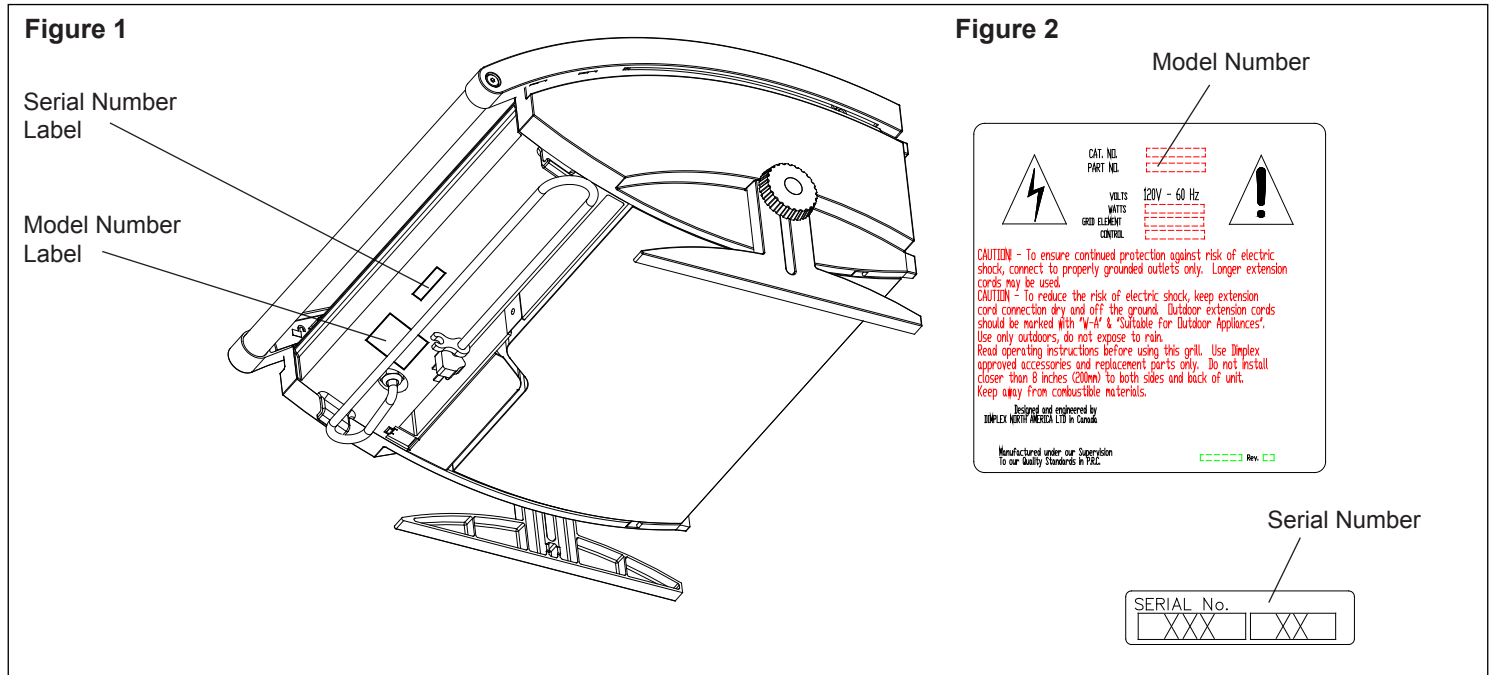

PowerChef Convertible Site Selection And Setup

NOTE: A Ground Fault Interrupt (GFI) outdoor outlet or a circuit protected by a ground fault breaker with a rating of 15 Amps, 120 Volts is strongly recommended. A dedicated circuit is preferred but not essential in all cases. A dedicated circuit will be required if, after installation, the circuit breaker trips or the fuse blows on a regular basis when the electric grill is operating. Additional appliances on the same circuit may exceed the current rating of the circuit breaker.

Construction and electrical outlet wiring must comply with local building codes and other applicable regulations to reduce the risk of fire, electric shock and injury to persons. Do not attempt to wire your own new outlets or circuits, and always use a licensed electrician.

CAUTION: To avoid personal injury and damage to unit, never move or transport with the lid open.

1. Select a suitable location away from puddles, pools, ponds, and hot tubs.

CAUTION: Do not place grill on surfaces covered by paper, plastic or vinyl table cloths and the like. **Wood, concrete, steel, or outdoor plastic furniture surfaces are recommended.**

2. Ensure the sides of the electric grill are positioned more than eight (8) inches (200 mm) away from any

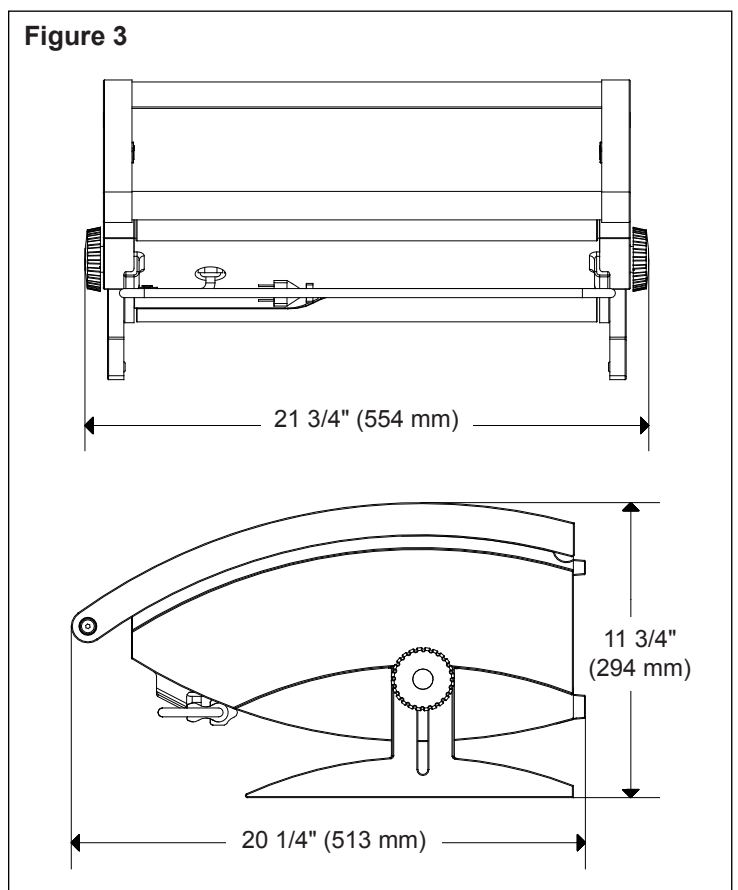

PowerChef Convertible Site Selection And Setup

Figure 4

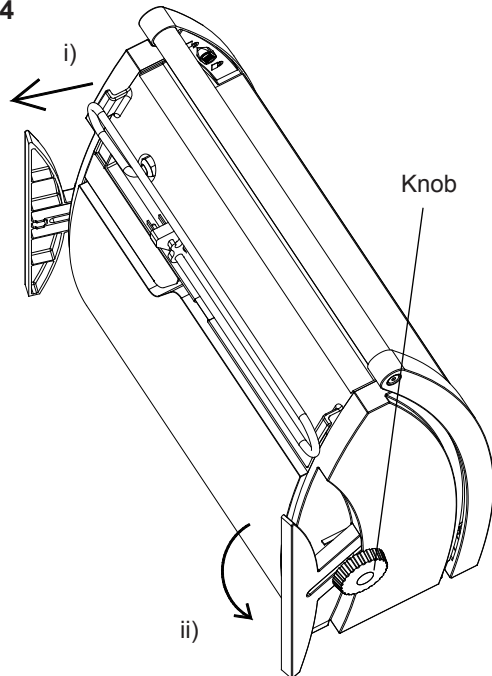
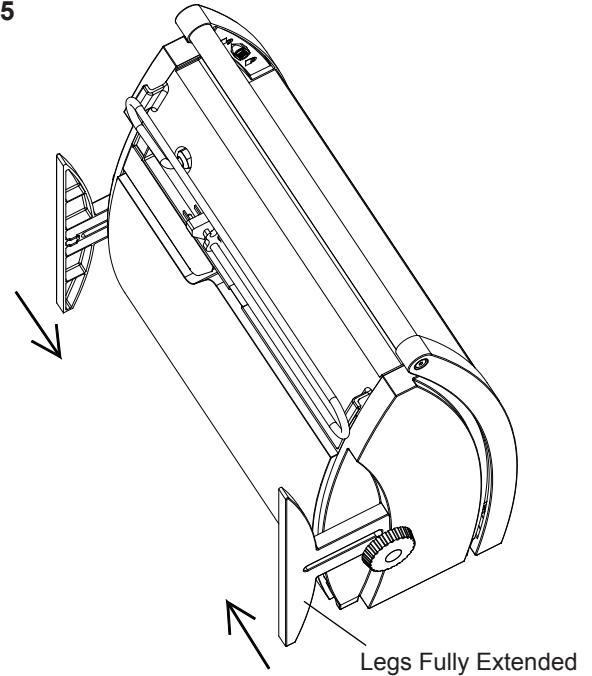

Figure 5



combustible material or surfaces before cooking. Refer to Figure 3 for dimensions of the electric grill.

3. Ensure that there are no flammable or other volatile materials in the direct area before grilling.
4. For ease of electrical hook up you may wish to locate the electric grill near an existing outlet. (Refer to NOTE above)
5. Stand the electric grill on its back.
6. Loosen but do not remove the two (2) knobs on either side of the grill. (Figure 4)
7. Pull out both support legs until the first stop tab is reached (Figure 4-i). Tilt the support legs outward as shown in Figure 4-ii to clear the stop tab and fully extend both support legs as indicated in Figure 5.
8. Move the support legs inward so that they are flush against the chassis and re-tighten the knobs to secure support legs in place. (Figure 5)

CAUTION: To maximize air flow under the grill and to prevent unnecessary wear to grill components, ensure support legs are fully extended before use.

9. Place grill on its feet and unwind the attached power cord from underneath the front edge. Route power cord to a power source. (See NOTE above)

WARNING: Ensure the power cord is not pinched or against a sharp edge. Ensure that the power cord is stored or secured to avoid tripping or snagging to reduce the risk of fire, electric shock or injury to persons. Never route power cord underneath the electric grill. Always route power cord directly out the side or front.

Figure 6

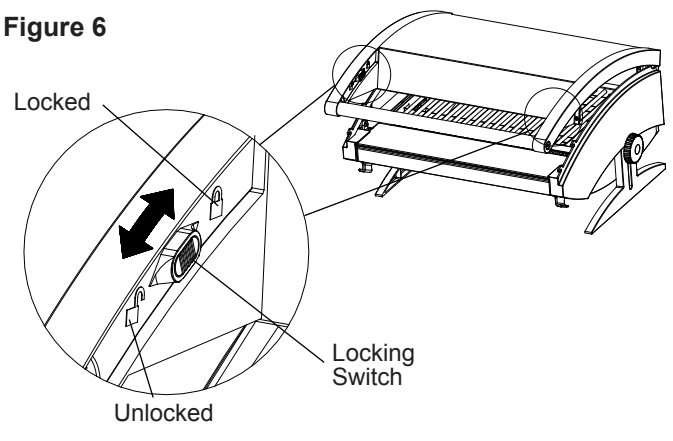

10. Unlock top lid by pressing each of the two (2) lid locks inward, and sliding them towards the front, inside corners of the lid. (Figure 6) To lock the lid in place for storage or transporting, close the lid, press the locks inward and slide them towards the rear of the grill lid.

NOTE: Once grill rests on fully extended legs, it will be possible to slightly rock the grill forward and back. This is normal and is due to the clearances required for moving parts within.

Guide To Your New PowerChef Convertible Electric Grill

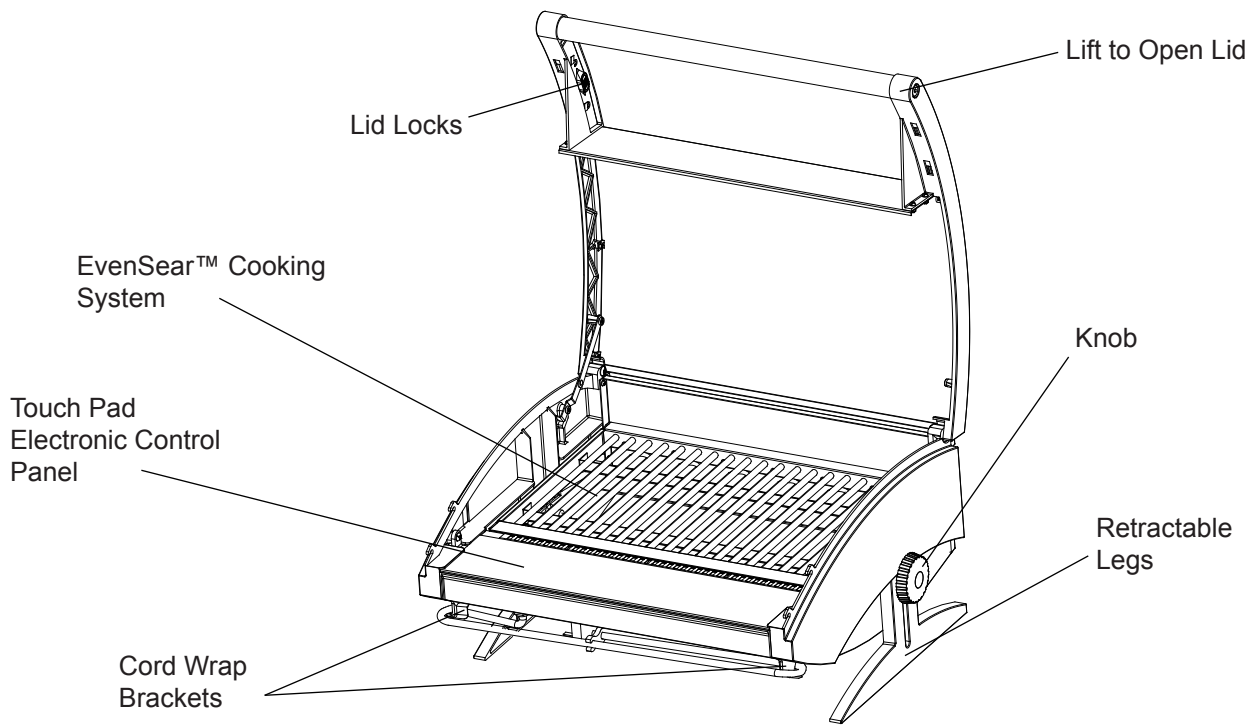

Operating Guide To Your PowerChef Convertible Control Panel

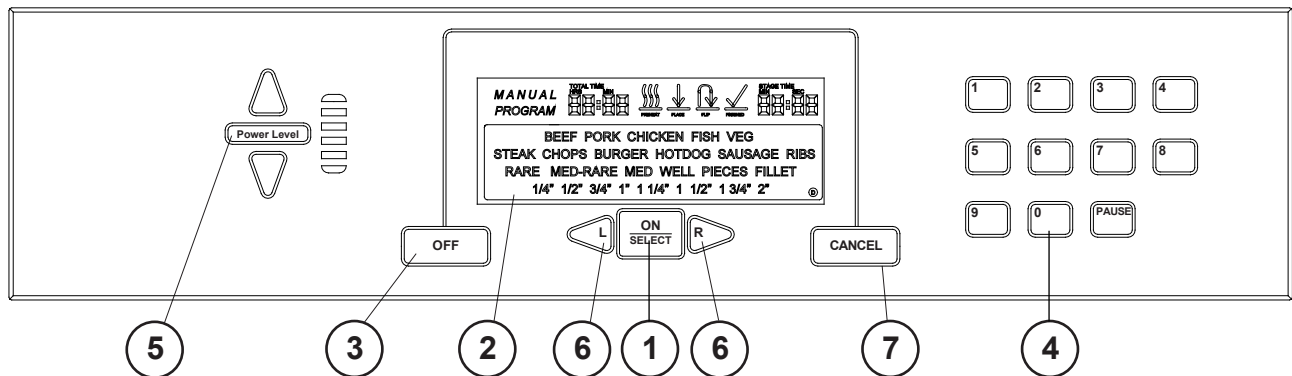

- 1 On/Select**
Use to turn on the unit and to confirm the selections, displayed.
- 2 Display**
Displays selection and status of operation.
- 3 Off**
Push TWICE to shut off the entire grill.
- 4 Key Pad**
Use the keypad to set cook timer when in manual operation.
- 5 Power Level**
Press up/down arrows to select desired power level. Use the power level up/down when in manual mode only.
- 6 Right/Left Arrows**
Use to navigate display selections.
- 7 Cancel**
Cancels the last selection from the display.

Advanced Features Of The PowerChef Convertible Control Panel

Automatic Power Saver

This feature activates immediately after a pre-programmed selection is finished cooking and "FINISHED" is shown on the display. The cooking grid power will shut off but the display will remain ON for up to four hours at which point it will shut off automatically. See the Safety Power-off for more information.

Safety Power-off

This feature activates if the unit has been accidentally left on after cooking. The power automatically shuts off to the entire unit four hours after the last button was touched on the control panel.

Overcook Protection

After each stage of cooking during the program mode, an alarm sounds indicating attention is required. If the ON/SELECT button is not pressed after the alarm sounds, the grill temperature automatically reduces to a low setting after a short period of time to prevent over cooking.

Voltage Compensation

The electric grill automatically adjusts the cook times based on any variance on input voltage.

Key Lock

This feature prevents accidental changes to your cooking program by locking the control panel when in use. When this feature is used all control panel functions are disabled. To activate the key lock press 1, 2, 3 in sequence and LOC will appear on the display screen. To deactivate the key lock press 1, 2, 3 in sequence and ULOC will appear on the display screen.

Preheat

Your PowerChef grill has an automatic 8 minute PREHEAT function once you've finalized your method of cooking. To skip the Preheat function press the CANCEL button after the program has started. A full PREHEAT is recommended when the grill is cold but may not be required if your grill is already heated from previous use.

PowerChef Convertible Operation - Manual Mode

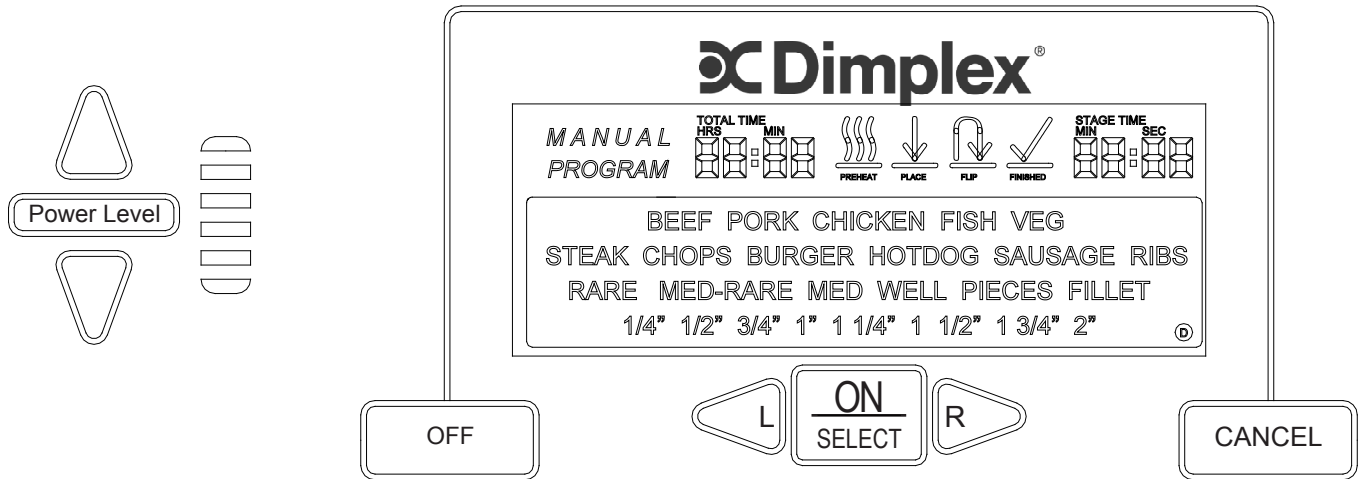

PowerChef Convertible Operation - Manual Mode

Operation	Display Reads	Action
To Use the Manual Feature		
Touch ON/SELECT button.	<i>MANUAL</i> (Flashing)	Initial start-up.
Touch ON/SELECT button & <i>MANUAL</i> is highlighted.	<i>PREHEAT</i>	Preheat for 8 minutes.
Alarm sounds.	<i>PLACE FOOD</i>	Grill is ready for cooking - place food.
Close hood & touch ON/SELECT button		Cooking is underway.
Touch up/down Power Level keys.	Power Level	Increases/decreases Power Level setting.
Touch OFF twice.	Blank	Grill is turned off.
*** Note: The timer can be used as a reference when using the MANUAL feature.		
Operation	Display Reads	Action
To Use the Timer with the Manual Feature		
Touch ON/SELECT button.	<i>MANUAL</i> (Flashing)	Initial start-up.
Touch ON/SELECT button & <i>MANUAL</i> is highlighted.	<i>PREHEAT</i>	Preheat for 8 minutes.
Alarm sounds.	<i>PLACE FOOD</i>	Grill is ready for cooking - place food.
Close hood & touch ON/SELECT button		Cooking is underway.
Touch up/down Power Level keys.	Power Level	Increases/decreases Power Level setting.
Touch number pad keys to enter desired time. Ex: Press "5" once for 5 minutes or "1, 3, 0" for 1 hour, 30 minutes.	<i>TOTAL TIME</i> displays hours/minutes entered from key pad.	Count down timer is now entered.
Touch ON/SELECT button.	<i>TOTAL TIME</i> begins to count down from time entered on key pad.	Timer is now activated. <i>TOTAL TIME</i> will count down in HRS: MINS, <i>STAGE TIME</i> will count down in :SECS.
**** NOTE: when the timer reaches 0, an alarm will sound with 3 beeps, power to the cooking grid shuts off and the display will show <i>FINISHED</i> . Touch the OFF button once to shut display off, and a second time to shut the grill off.		

PowerChef Convertible Operation - Program Mode

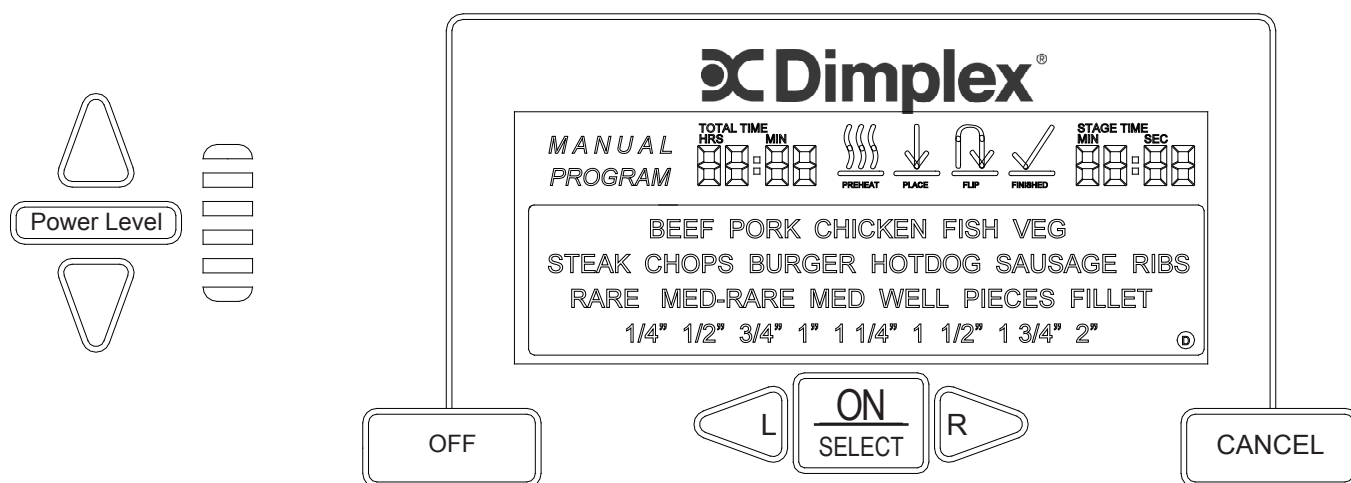

Operation	Display Reads	Action
To Use Program Feature		
Touch ON/SELECT button.	<i>MANUAL</i> (Flashing)	Initial start-up.
Touch R (right) Arrow.	<i>PROGRAM</i>	Shifts operation from <i>MANUAL</i> to <i>PROGRAM</i> mode.
Touch ON/SELECT button.	<i>PROGRAM</i>	Completes <i>PROGRAM</i> mode set up.
To Cook Your Selected Food		
Touch R/L arrows until choice is illuminated.	<i>BEEF</i>	Highlights food choice.
	<i>CHICKEN</i>	
	<i>PORK</i>	
	<i>FISH</i>	
	<i>VEG</i>	
	<i>SAUSAGE</i>	
	<i>RIBS</i>	
Touch ON/SELECT button.	<i>F1</i>	Selects food choice.
	Your choice remains illuminated.	

Depending on your food choice, you will be prompted to highlight and select secondary food choice description. (e.g. Beef Steak or Beef Burgers). Use the Right/Left Arrow and the On/Select button to highlight and select your choice.

Depending on your food choice, you may be prompted to select the thickness of the food to be cooked. (e.g. 1/4", 1/2", 3/4", 1", 1 1/4", 1 1/2", 1 3/4", 2"). Use the Right/Left Arrow button and the On/Select button to highlight and select your choice.

Depending on your food choice, you may be prompted to select how you want your food prepared. (e.g. Rare, Medium Rare, Medium or Well Done). Use the Right/Left Arrow button and the On/Select button to highlight and select your choice.

PowerChef Convertible Operation - Program Mode

Once your food and cooking choices have been selected:

Operation	Display Reads	Action
Food choice selections (as above).	<i>PREHEAT</i> - <i>STAGE TIME</i> begins to count down from 8 minutes and <i>TOTAL TIME</i> displays total cooking time.	Grill is preheating.
Alarm sounds.	<i>PREHEAT</i> changes to <i>PLACE FOOD</i> and <i>TOTAL TIME</i> pauses.	Grill is preheated and ready to cook.
Place foods on grill and close hood. Touch ON/SELECT button.	<i>PLACE FOOD</i> indicator goes off. <i>TOTAL TIME</i> commences countdown. <i>STAGE TIME</i> counts down to next stage.	Cooking is underway.
Alarm sounds to turn food over.	<i>TURN FOOD</i> appears, <i>TOTAL TIME</i> pauses, <i>STAGE TIME</i> is completed.	Grill is indicating it is time to turn food over. Turn food and close hood.
Food is turned and hood is closed. Touch ON/SELECT button.	<i>TURN FOOD</i> goes off. <i>TOTAL TIME</i> resumes. <i>STAGE TIME</i> counts down to next stage.	Cooking of reverse side of food is underway.

! NOTE: Depending on food choice and cooking choice, you may be prompted to repeat the last two steps.

Operation	Display Reads	Action
Alarm sounds.	<i>FINISHED</i> is highlighted. <i>TOTAL TIME</i> and <i>STAGE TIME</i> show 00:00.	Food cooking program is completed.
Touch ON/SELECT or CANCEL button to finish the program.	All indicators are off.	Food is ready.
Touch OFF button.	All indicators are off.	Grill is shutting down.

! NOTE: All program cooking times assume food is thawed before cooking (except hamburger patties).

PowerChef Convertible Care And Cleaning

⚠ WARNING: Unplug the electric grill from outlet when not in use or before cleaning. Do not clean this product with high pressure water spray.

Allow electric grill to cool before covering. Cover the electric grill when not in use.

Control Panel Glass

To clean the control panel glass use a non abrasive glass cleaner or damp, soft cloth or sponge with a mild detergent. Follow with a clean damp cloth to remove any remaining detergent residue.

Drip Tray

⚠ CAUTION: Allow the grill to cool before attempting to clean the Drip Tray. Never use the electric grill without the Drip Tray and Tray Liner in place.

The Drip Tray is located under the cooking grid. We recommend the Drip Tray be lined with aluminum foil or use a non-stick cooking spray to make clean-up easier.

! NOTE: Although possible to clean the Drip Tray while the Convertible Grill is sitting on it's support legs, the following procedure is recommended for ease of access.

To clean Drip Tray:

1. Lock the grill's lid closed. (Refer to page 3 for instructions)
2. Stand the Convertible Electric Grill onto it's back.
3. Keeping one hand to support the Drip Tray, use your other hand to pull the release tab as shown in Figure 7.
4. Use a paper towel or cloth to soak up any excess liquid. Then, use a clean damp, soft cloth or sponge with a mild detergent to clean any remaining debris. Follow with a clean damp cloth or paper towel to removed any remaining detergent residue.
5. Relocate the Drip Tray into position by following steps 1 through 3 in reverse order.

Cooking Grid

To keep your electric grill operating at optimal performance Dimplex recommends that you clean the cooking grid after each use.

The cooking grid is permanently mounted into the body of the electric grill and cannot be removed.

Do Not Attempt To Remove The Cooking Grill.

For best results when cleaning:

1. Clean grill after every use.
2. While grill is still warm, use a stiff wire brush and clear grill of all food particles. A scraper can be used to remove difficult particles.

⚠ WARNING: Never strike cooking grid to remove residue.

Figure 7

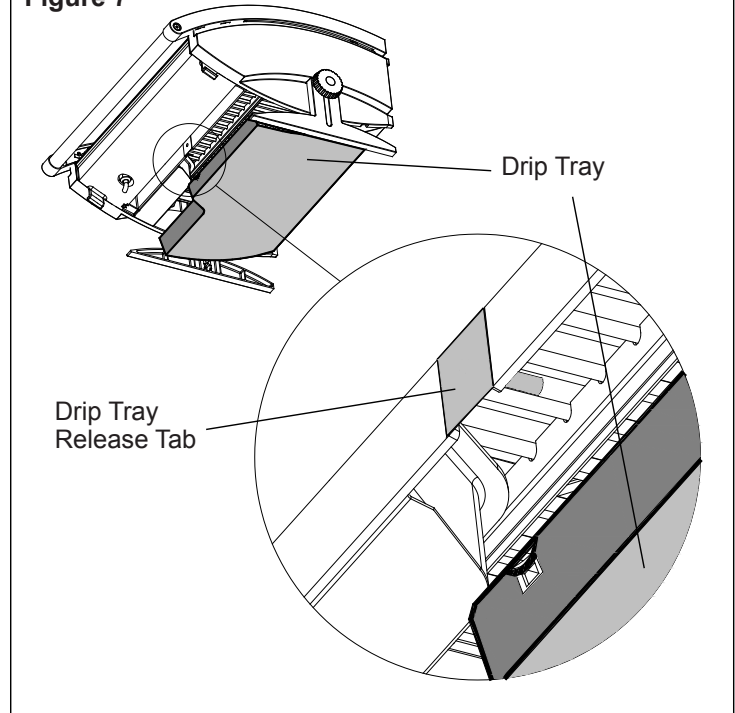

3. After grill has cooled, follow up brushing and/or scraping by wiping cooking surface with a damp, soft cloth or sponge with a detergent or grill cleaner. Follow with a clean damp cloth to remove any remaining detergent residue.
4. To clean under the cooking grid, access from underneath by lowering the Drip Tray as described in steps 1 through 3 under the Drip Tray cleaning section.

Surface Cleaning

To clean any metallic surface, Dimplex recommends using a damp, soft cloth or sponge with a mild detergent. Follow with a clean damp cloth to remove any remaining detergent residue.

Do not use abrasive or strong cleaners or cleaning pads on any surface of the electric grill. Doing so may diminish your grill's surface sheen.

Storage

For seasonal storage, cover and store in a dry location away from the elements.

One Year Limited Warranty

Products to which this limited warranty applies

This limited warranty applies to newly purchased Dimplex electric grill. This limited warranty applies only to purchases made in any province of Canada *except* for Yukon Territory, Nunavut, or Northwest Territories or in any of the 50 States of the USA (and the District of Columbia) *except* for Hawaii and Alaska. This limited warranty applies to the original purchaser of the product only and is not transferable.

Products excluded from this limited warranty

Products purchased in Yukon Territory, Nunavut, Northwest Territories, Hawaii, or Alaska are not covered by this limited warranty. Products purchased in these States, provinces, or territories are sold AS IS without warranty or condition of any kind (including, without limitation, any implied warranties or conditions of merchantability or fitness for a particular purpose) and the entire risk of as to the quality and performance of the products is with the purchaser, and in the event of a defect the purchaser assumes the entire cost of all necessary servicing or repair.

What this limited warranty covers and for how long

Products covered by this limited warranty have been tested and inspected prior to shipment and, subject to the provisions of this warranty, Dimplex warrants such products to be free from defects in material and workmanship for a period of 12 months from the date of the first purchase of such product.

The limited 12 month warranty period also applies to any implied warranties that may exist under applicable law. Some jurisdictions do not allow limitations on how long an implied warranty lasts, so the above limitation may not apply to the purchaser.

What this limited warranty does not cover

This limited warranty does not apply to products that have been repaired (except by Dimplex or its authorized service representatives) or otherwise altered. This limited warranty does further not apply to defects resulting from misuse, abuse, accident, neglect, incorrect installation, improper maintenance or handling, or operation with an incorrect power source.

What you must do to get service under this limited warranty

Defects must be brought to the attention of Dimplex Technical Service by contacting Dimplex at 1-888-DIMPLEX (1-888-346-7539), or 1367 Industrial Road, Cambridge Ontario, Canada N1R 7G8. Please have proof of purchase, catalogue/model and serial numbers available when calling. Limited warranty service requires a proof of purchase of the product.

What Dimplex will do in the event of a defect

In the event a product or part covered by this limited warranty is proven to be defective in material or workmanship during the 12 month limited warranty period you have the following rights:

- Dimplex will in its sole discretion either repair or replace such defective product or part without charge. If Dimplex is unable to repair or replace such product or part, or if repair or replacement is not commercially practicable or cannot be timely made, Dimplex may, in lieu of repair or replacement, choose to refund the purchase price for such product or part.
- Limited warranty service will be performed solely by dealers or service agents of Dimplex authorized to provide limited warranty services.
- The purchaser is responsible for removal and transportation of such product or part (and any repaired or replacement product or part) to and from the authorized dealer's or service agent's place of business.
- Dimplex will not be responsible for, and the limited warranty services shall not include, any expense incurred for installation or removal of the product or part (or any replacement product or part) or any labour or transportation costs. Such costs shall be the purchaser's responsibility.

What Dimplex and its dealers and service agents are also not responsible for:

IN NO EVENT WILL DIMPLEX, OR ITS DIRECTORS, OFFICERS, OR AGENTS, BE LIABLE TO THE PURCHASER OR ANY THIRD PARTY, WHETHER IN CONTRACT, IN TORT, OR ON ANY OTHER BASIS, FOR ANY INDIRECT, SPECIAL, PUNITIVE, EXEMPLARY, CONSEQUENTIAL, OR INCIDENTAL LOSS, COST, OR DAMAGE ARISING OUT OF OR IN CONNECTION WITH THE SALE, MAINTENANCE, USE, OR INABILITY TO USE THE PRODUCT, EVEN IF DIMPLEX OR ITS DIRECTORS, OFFICERS, OR AGENTS HAVE BEEN ADVISED OF THE POSSIBILITY OF SUCH LOSSES, COSTS OR DAMAGES, OR IF SUCH LOSSES, COSTS, OR DAMAGES ARE FORESEEABLE. IN NO EVENT WILL DIMPLEX, OR ITS OFFICERS, DIRECTORS, OR AGENTS BE LIABLE FOR ANY DIRECT LOSSES, COSTS, OR DAMAGES THAT EXCEED THE PURCHASE PRICE OF THE PRODUCT.

SOME JURISDICTIONS DO NOT ALLOW THE EXCLUSION OR LIMITATION OF INCIDENTAL OR CONSEQUENTIAL DAMAGES, SO THE ABOVE LIMITATION OR EXCLUSION MAY NOT APPLY TO THE PURCHASER.

How State and Provincial law apply

This limited warranty gives you specific legal rights, and you may also have other rights which vary from jurisdiction to jurisdiction. The provisions of the United Nations Convention on Contracts for the Sale of Goods shall not apply to this limited warranty or the sale of products covered by this limited warranty.