

# **Demco** manufacturing

*Dethmers Manufacturing Company*

## **Kar-Kaddy SS**

### **KK460SS**

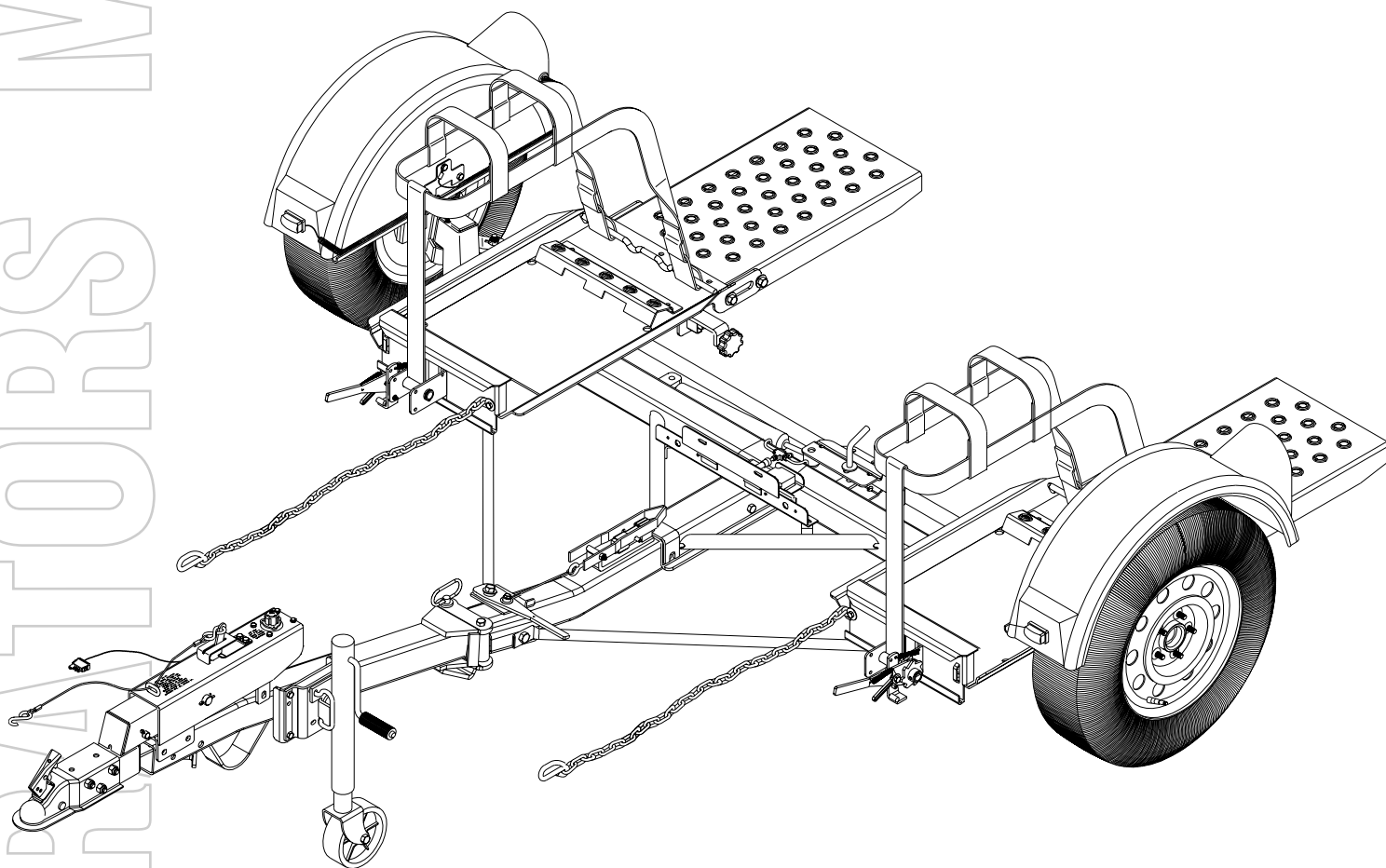

ASSEMBLY  
CALIBRATION  
OPERATION  
REPLACEMENT PARTS

**READ** complete manual *CAREFULLY*  
*BEFORE* attempting operation.

*Doing Our Best To Provide You The Best*

## Introduction

Thank you for purchasing a Demco Kar-Kaddy. We feel you have made a wise choice and hope you are completely satisfied with your new piece of equipment.

## GENERAL INFORMATION

1. Unless otherwise specified, high-strength (grade 5) (3 radial-line head markings) hex head bolts are used throughout assembly of this piece of equipment.
2. Whenever the terms "**LEFT**" and "**RIGHT**" are used in this manual it means from a position behind the Kar-Kaddy and facing forward.
3. When placing a parts order, refer to this manual for proper part numbers and place order by **PART NO. and DESCRIPTION.**

## TABLE OF CONTENTS

|  |             |
|--|-------------|
| General Information .....  | Page 2      |
| Safety, You can Live With .....  | Page 3-7    |
| Decal Location .....   | Page 8      |
| Bolt Torque .....  | Page 9      |
| Tongue and Ramp Assembly .....   | Page 10     |
| Fender Assembly .....  | Page 11     |
| Wiring Diagram .....   | Page 12     |
| Testing Lights .....   | Page 12     |
| Tongue Folding .....   | Page 13     |
| Folding Ramps .....  | Page 14-15  |
| Loading Angle Clearance Guide .....  | Page 15     |
| Safety, Maintenance, & Important Loading Instructions .....                                | Page 16     |
| Loading Instructions .....   | Pages 17-19 |
| Toe-In Adjustment .....  | Page 20     |
| DA91 Brake Actuator Parts Breakdown and List .....   | Page 21     |
| 10" Self-Adjusting Brake Cluster Parts Breakdown and List .....                            | Page 22     |
| Brakes Line Parts Breakdown and List .....   | Page 23     |
| Kar-Kaddy Breakdown Parts Assembly Instructions .....                                      | Pages 24-25 |
| Winch and Tilt-Bed Parts Breakdown .....   | Page 26     |
| Ramp Latch and License Plate Bracket Parts Breakdown .....                                 | Page 27     |
| Fender Parts Breakdown .....   | Page 28     |
| Winch, Tool Box, & Spare Tire w/Mounting Bracket (optional) Parts Breakdown and List ..... | Page 29     |
| Deflector, & Light Bar (optional) Parts Breakdown and List .....                           | Page 30     |
| Product Warranty .....   | Page 31     |
| Warranty Registration .....  | Page 33-34  |

### "Reporting Safety Defects"

If you believe that your vehicle has a defect which could cause a crash or could cause injury or death, you should immediately inform the National Highway Traffic Safety Administration (NHTSA) in addition to notifying Dethmers Manufacturing Company (DEMCO).

If NHTSA receives similar complaints, it may open an investigation, and if it finds that a safety defect exists in a group of vehicles, it may order a recall and remedy campaign. However, NHTSA cannot become involved in individual problems between you, your dealer, or Dethmers Manufacturing Company (DEMCO).

To contact NHTSA, you may either call the Auto Safety Hotline toll-free at 1-800-424-9393 (or 366-0129 in Washington, D.C. area) or write to:

NHTSA,  
U.S. Department of Transportation  
Washington, D.C. 20590.

You can also obtain other information about motor vehicle safety from the Hotline.

## SAFETY

**TAKE NOTE! THIS SAFETY ALERT SYMBOL FOUND THROUGHOUT THIS MANUAL IS USED TO CALL YOUR ATTENTION TO INSTRUCTIONS INVOLVING YOUR PERSONAL SAFETY AND THE SAFETY OF OTHERS. FAILURE TO FOLLOW THESE INSTRUCTIONS CAN RESULT IN INJURY OR DEATH.**



**THIS SYMBOL MEANS**

**ATTENTION**

**BECOME ALERT**

**YOUR SAFETY IS INVOLVED!**

### **SIGNAL WORDS**

Note the use of the signal words **DANGER**, **WARNING** and **CAUTION** with the safety messages. The appropriate signal word for each has been selected using the following guidelines:

#### **DANGER:**

Indicates an imminently hazardous situation that, if not avoided, will result in death or serious injury.

#### **WARNING:**

Indicates a potentially hazardous situation that, if not avoided, could result in death or serious injury. It may also be used to alert against unsafe practices.

#### **CAUTION:**

Indicates a potentially hazardous situation that, if not avoided, may result in minor or moderate injury. It may also be used to alert against unsafe practices.

If you have questions not answered in this manual, or require additional copies, please contact your dealer or Dethmers Mfg. Co., P.O. Box 189, 4010 320th Street, Boyden, IA 51234  
ph: (712) 725-2311 Toll Free: 1-800-543-3626 Fax: (712) 725-2380 or 1-800-845-6420  
<http://www.demco-products.com>



### **REMEMBER**

Your best assurance against accidents is a careful and responsible operator. If there is any portion of this manual or method of operation you do not understand, contact your local authorized dealer or manufacturer.

# SAFETY...YOU CAN LIVE WITH IT



## EQUIPMENT SAFETY GUIDELINES

Every year many accidents occur which could have been avoided by a few seconds of thought and a more careful approach to handling equipment. You, the operator, can avoid many accidents by observing the following precautions in this section. To avoid personal injury, study the following precautions and insist those working with you, or you yourself, follow them.

Replace any caution, warning, danger or instruction safety decal that is not readable or is missing. Location of such decals is indicated in this booklet.

Do not attempt to operate this KK460SS under the influence of alcohol or drugs.

Review the safety instructions with all users.

Operator should be a responsible adult. **DO NOT ALLOW PERSONS TO OPERATE OR ASSEMBLE THIS UNIT UNTIL THEY HAVE DEVELOPED A THOROUGH UNDERSTANDING OF THE SAFETY PRECAUTIONS AND HOW IT WORKS.**

Do not paint over, remove, or deface any safety signs or warning decals on your KK460SS . Observe all safety signs and practice the instructions on them.

Never exceed the limits of a Kar Kaddy SS If its ability to do a job safely is in question  
**DON'T TRY IT.**



## LIGHTING AND MARKING

It is the responsibility of owner to know lighting and marking requirements of local highway authorities and to install and maintain equipment to provide compliance with regulations.

Light bar kits are available from your dealer or from manufacturer.



## TIRE SAFETY

- Failure to follow proper procedures when mounting a tire on a rim can produce an explosion which may result in serious injury or death.
- Do not attempt to mount a tire unless you have proper equipment and experience to do the job.
- Inflating or servicing tires can be dangerous. Whenever possible, trained personnel should be called to service and/or mount tires.
- KK460SS tires must be inflated to recommended P.S.I. . See decal on KK460SS for correct pressure.
- Always order and install tires and wheels with appropriate type and load capacity to meet or exceed gross weight of unit.



## SAFETY SIGN CARE

- Keep safety signs clean and legible at all times.
- Replace safety signs that are missing or have become illegible.

- Replacement parts that displayed a safety sign should also display current sign.
- Safety signs are available from your distributor, dealer parts department, or factory.

**How to install safety signs:**

- Be sure installation surface is clean and dry.
- Decide on exact position before you remove backing paper.
- Remove smallest portion of split backing paper.
- Align decal over specified area and carefully press small portion with exposed sticky backing in place.
- Slowly peel back remaining paper and carefully smooth remaining portion of decal into place.
- Small air pockets can be pierced with a pin and smoothed out using piece of decal backing paper.



**BEFORE OPERATION:**

- Carefully study and understand this manual.
- Keep wheel and lug nuts tightened to specified torque.
- Assure tires are inflated evenly.
- Give unit a visual inspection for any loose bolts, worn parts, or cracked welds, and make necessary repairs. Follow maintenance safety instructions included in this manual.
- Be sure there are no tools lying on or in KK460SS
- Do not use unit until you are sure that area is clear, especially around children and animals.
- Don't hurry learning process or take unit for granted. Ease into it and become familiar with your new KK460SS
- Practice operation of your KK460SS and its attachments. Completely familiarize yourself and other operators with its operation before using.
- Make sure that brakes are evenly adjusted (if equipped with brakes)
- Securely attach to towing vehicle. Use an appropriately sized and rated hitch ball and attach safety chains.
- Do not allow anyone to stand between tongue or hitch and towing vehicle when backing up to unit.
- Make sure tow rating on vehicle is high enough for what it is towing.



**DURING OPERATION**

- **SAFETY CHAIN** - Always follow state and local regulations regarding safety chains and auxiliary lighting when towing. Be sure to check with local law enforcement agencies for your own particular regulations. Only safety chains (not elastic or nylon/plastic tow straps) should be used to retain connection between towing vehicle and towed unit in event of separation.
- Do not load towed vehicle with cargo. Towed vehicles exceeding weight limits will overload KK460SS and may cause serious injury and damage.
- Criss cross safety chains under tongue, secure to mounting loops on towing vehicle.

- Secure emergency brake actuator cable to mounting loop on towing vehicle.
- Beware of bystanders, **PARTICULARLY CHILDREN!** Always look around to make sure it is safe to start engine of towing vehicle or move unit. This is particularly important with higher noise levels, as you may not hear people shouting.
- **NO PASSENGERS ALLOWED-** Do not carry passengers anywhere on or in towed unit.
- When halting operation, even periodically, set towing vehicle parking brake, shut off engine, and **remove ignition key**.
- Be extra careful on inclines.
- **MANEUVER TOWING VEHICLE AT SAFE SPEEDS. Do not exceed 55 M.P.H.**
- Avoid overhead wires or other obstacles. Contact with overhead lines could cause serious injury or death.
- Avoid loose gravel, rocks, and holes; they can be dangerous for unit operation or movement.
- Allow for unit length when making turns.
- Do not work under raised components or attachments unless securely positioned and blocked.
- Keep all bystanders and pets clear of work area.
- Operate towing vehicle from operators seat only.
- As a precaution, recheck hardware on KK460SS every 50 miles, and correct all problems. Follow maintenance safety procedures.



## **FOLLOWING OPERATION**

- Following operation, or when unhitching, stop towing vehicle, set parking brake, shut off engine and **remove ignition key**.
- Store KK460SS in area away from human activity.
- Do not permit children to play on or around stored KK460SS.
- Make sure parked KK460SS is on hard, level surface.
- Wheel chocks may be needed to prevent unit from rolling.



## **HIGHWAY AND TRANSPORT OPERATIONS**

- Adopt safe driving practices:
  - Always drive at safe speed relative to local conditions and ensure that your speed is low enough for an emergency stop. **Do not exceed 55 M.P.H.**
  - Reduce speed prior to turns to avoid risk of overturning.
  - Always keep towing vehicle in gear to provide engine braking when going downhill. **Do not coast.**
  - **Do not drink and drive!**
- Comply with state and local laws governing highway safety.

- Local laws should be checked for all highway lighting and marking requirements.
- Plan your route to avoid heavy traffic.
- Be a safe and courteous driver. Always yield to oncoming traffic in all situations, including narrow bridges, intersections, etc.
- Watch for obstructions overhead and to both sides while transporting.
- Operate with maximum visibility at all times. Make allowances for increased length and weight of KK460SS when making turns and stopping.



## **PERFORMING MAINTENANCE**

- Good maintenance is your responsibility. Poor maintenance is an invitation to trouble.
- Make sure there is plenty of ventilation. Never operate engine of towing vehicle in a closed building. Exhaust fumes may cause asphyxiation.
- Before working on KK460SS, stop towing vehicle, set parking brake, turn off engine and **remove ignition key**.
- Always block wheels and never use a jack as sole support.
- Always use proper tools or equipment for job at hand.
- Use extreme caution when making adjustments.
- Follow torque chart in this manual when tightening bolts and nuts.
- Openings in skin and minor cuts are susceptible to infection from brake fluid.  
**Without immediate medical treatment, serious infection and reactions can occur.**
- After servicing, be sure all tools, parts and service equipment are removed.
- Do not allow grease or oil to build up on any step or platform.
- When replacing bolts, refer to owners manual for proper size and grade.
- Refer to bolt torque chart for head identification marking.
- Where replacement parts are necessary for periodic maintenance and servicing, genuine factory replacement parts must be used to restore your KK460SS to original specifications. Manufacturer will not claim responsibility for use of unapproved parts and/or accessories or other damages as a result of their use.
- If KK460SS has been altered in any way from original design, manufacturer does not accept any liability for injury or warranty.
- A fire extinguisher and first aid kit should be kept readily accessible while performing maintenance on this KK460SS

# Decal Location



REV 0

DD21018

A. DD21018



D. DD21017 QTY. 4



## WARNING

To prevent serious injury or death. Make sure tongue is in forward locked position with locking pin and retainer clip properly installed before hooking up or loading.

REV 0

DD21019

B. DD21019 QTY. 1

Keep wheel nut torque to 120 ft.lbs. Maintain tire pressure at 50 P.S.I. Cold

F. RD21008 QTY. 2



E. RD21002 QTY. 1

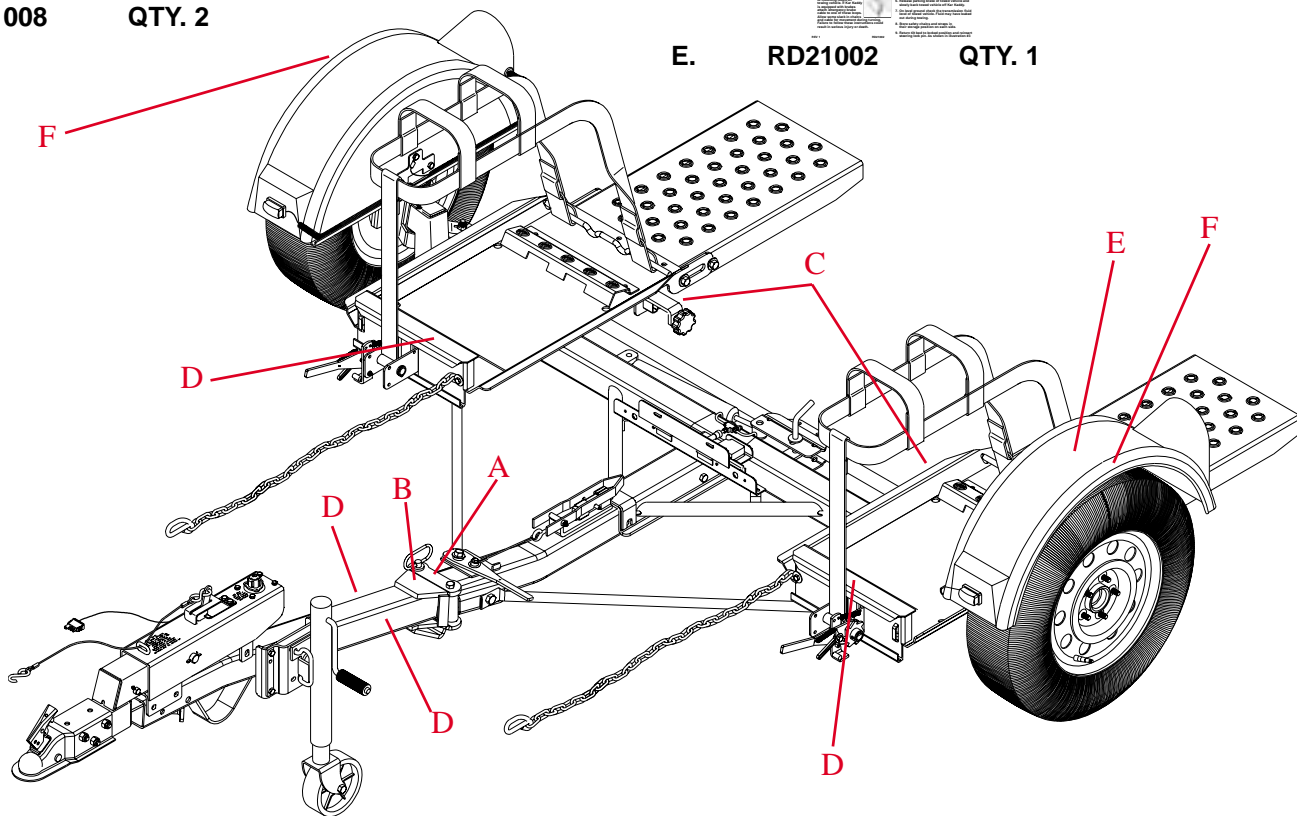

**PULL & LIFT  
TO  
FOLD RAMP**

Rev 0

DD21020

C. DD21020 QTY. 2

### WINCH OPERATING INSTRUCTIONS

Remove winch lock pins (A) from strap winches on front of tow dolly.  
**Release winch:** Grasp handle (B) squeeze trigger (C) push down and pull all excess strap from winch. Lay tire strap to outside of tow dolly.  
**Tighten straps:** Place tire straps over tires centering straps and winches to tires. While tightening straps, pull excess strap forward to ensure even tightening. Tighten straps until each tire starts to flatten against tire stop. After strap is tight, insert lock pin into winch.

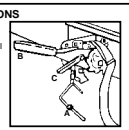

REV 1

DD21016

F. DD21016 QTY. 2



# BOLT TORQUE

## TORQUE DATA FOR STANDARD NUTS, BOLTS, AND CAPSCREWS.

Tighten all bolts to torques specified in chart unless otherwise noted. Check tightness of bolts periodically, using bolt chart as guide. Replace hardware with same grade bolt.

NOTE: Unless otherwise specified, high-strength Grade 5 hex bolts are used throughout assembly of equipment.

### Bolt Torque for Standard bolts \*



### Torque Specifications

**Torque Lug Nuts to 120 FT/LBS**

| "A"   | GRADE 2 |       | GRADE 5 |       | GRADE 8 |        |
|-------|---------|-------|---------|-------|---------|--------|
|       | lb-ft   | (N.m) | lb-ft   | (N.m) | lb-ft   | (N.m)  |
| 1/4"  | 6       | (8)   | 9       | (12)  | 12      | (16)   |
| 5/16" | 10      | (13)  | 18      | (25)  | 25      | (35)   |
| 3/8"  | 20      | (27)  | 30      | (40)  | 45      | (60)   |
| 7/16" | 30      | (40)  | 50      | (70)  | 80      | (110)  |
| 1/2"  | 45      | (60)  | 75      | (100) | 115     | (155)  |
| 9/16" | 70      | (95)  | 115     | (155) | 165     | (220)  |
| 5/8"  | 95      | (130) | 150     | (200) | 225     | (300)  |
| 3/4"  | 165     | (225) | 290     | (390) | 400     | (540)  |
| 7/8"  | 170     | (230) | 420     | (570) | 650     | (880)  |
| 1"    | 225     | (300) | 630     | (850) | 970     | (1310) |

### Bolt Torque for Metric bolts \*

Torque figures indicated are valid for non-greased or non-oiled threads and heads unless otherwise specified. Therefore, do not grease or oil bolts or capscrews unless otherwise specified in this manual. When using locking elements, increase torque values by 5%.

| "A" | CLASS 8.8 |       | CLASS 9.8 |       | CLASS 10.9 |        |
|-----|-----------|-------|-----------|-------|------------|--------|
|     | lb-ft     | (N.m) | lb-ft     | (N.m) | lb-ft      | (N.m)  |
| 6   | 9         | (13)  | 10        | (14)  | 13         | (17)   |
| 7   | 15        | (21)  | 18        | (24)  | 21         | (29)   |
| 8   | 23        | (31)  | 25        | (34)  | 31         | (42)   |
| 10  | 45        | (61)  | 50        | (68)  | 61         | (83)   |
| 12  | 78        | (106) | 88        | (118) | 106        | (144)  |
| 14  | 125       | (169) | 140       | (189) | 170        | (230)  |
| 16  | 194       | (263) | 216       | (293) | 263        | (357)  |
| 18  | 268       | (363) | --        | --    | 364        | (493)  |
| 20  | 378       | (513) | --        | --    | 515        | (689)  |
| 22  | 516       | (699) | --        | --    | 702        | (952)  |
| 24  | 654       | (886) | --        | --    | 890        | (1206) |

\* GRADE or CLASS value for bolts and capscrews are identified by their head markings.

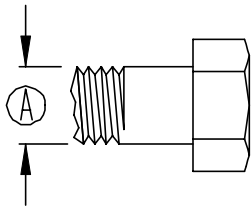

GRADE-2

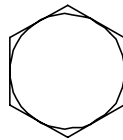

GRADE-5

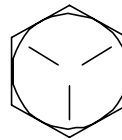

GRADE-8

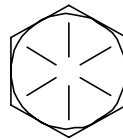

CLASS 8.8



CLASS 9.8



CLASS 10.9

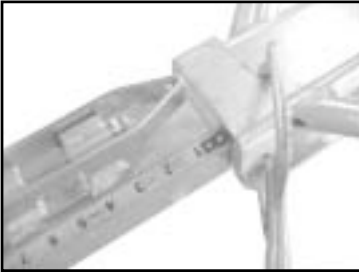

## Tongue and Ramp Assembly Instructions

1. Place the main frame (#1) on blocks or some other sturdy support so that the frame rests approximately 8" - 10" off the ground.
2. With an assistant, place tongue assembly (#2) into main frame channel and position latch on tongue approximately 3" from front of channel. Clamp tongue to main frame and support front of tongue.
 
3. Locate the four bullet connectors extending out the back of the tongue and plug into the connector protruding from under the main frame channel. Plug into the flat four connector by matching the colors. Do not cross colors when making this connection. Make sure that the two pigtails for the license plate bracket are out.
4. Using the open end of a 9/16" wrench to support the back of the male coupler, (as shown below) push drip free quick couplers together. (Factory setup units will not have quick couplers)
5. With an assistant, mount the tongue assembly (#2) to the front of the Kar Kaddy main frame and use a 5/8" x 4-1/2" grade 5 bolt (#3) and lock nut (#4) (torque to 50 ft. lbs). Do not torque over 50 ft. lbs. or bed will not tilt.
 

**NOTE:** Brake line and wiring must be above bolt also coupler assembly must be ahead of bolt. Do this by opening tongue about half way.
6. Lay the bracing struts (#5) out along the tow dolly tongue with the back end (the end with the larger hole in it) of the bracing strut toward the main frame. Loosely bolt the back

of each bracing strut to the trailer frame as shown using 1/2" x 1-1/2" grade 5 bolt (#6), flatwasher (#7), pivot bushing (#8) and locknut (#9). Hold up the front end (the end with the smaller hole) of each bracing strut to the tongue and secure with two 5/8" x 1-1/4" epoxied hex head bolts (#10) and nut plate (#14). Torque the 1/2" x 1-1/2" bolt with the pivot bushing to 75 ft. lbs. Torque the two 5/8" x 1-1/4" epoxied hex head bolts to 100 ft. lbs.

7. On the main unit, pull ramp latch (#11) out and up in unlatched position.
8. Use four 1/2" x 1-1/2" bolts (#6), 1/2" flat washers (#7) and yellow plated bushings (#12) and place in the front slotted hole and the rear slotted hole on both sides of ramp (#13). Use four 1/2" nylon lock nuts (#9) and snug these bolts so they can slide up and down in slot.
9. Place ramp (#13) in main frame (#1). Front bolts and bushings go in front open slot of ramp mount. Lift ramp up and push forward until rear bolts and bushings go into rear half slot.
10. Engage Ramp latch (#11) and move ramp around so latch can engage through ramp. With the use of two clamps, secure ramp to main frame. Install the remaining 1/2" x 1-1/2" bolts (#6), flatwashers (#7), yellow bushings (#12), and nylon lock nuts (#9) into the remaining slotted holes.
11. Tighten all six bolts. Pull and lift ramp latch (#11) and pull ramp back and fold up. If ramp is too tight when pulling back, reclamp ramp as in previous step and loosen bolts so ramp lowers away from main frame. Tighten bolts and retry.
12. Repeat steps 7-11 for other side.

Connecting Drip Free Quick Coupler  
brake couplers.  
Not needed for factory setup units.

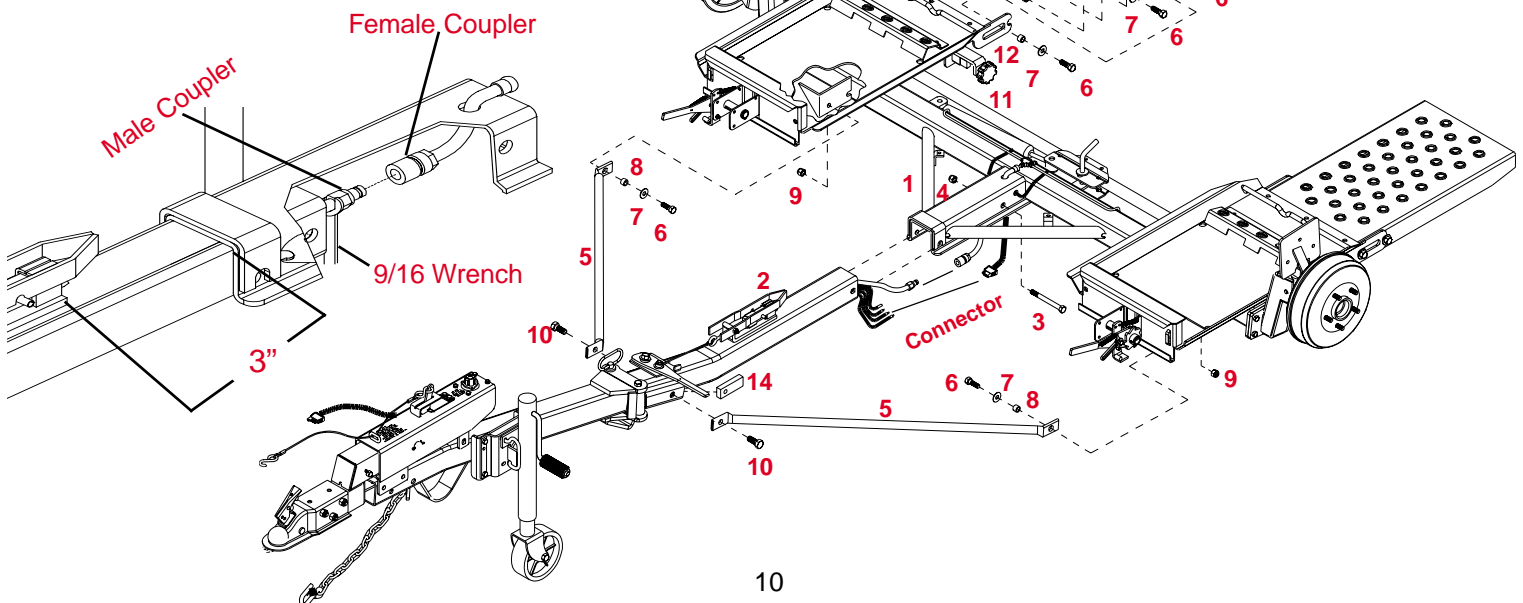

## Fender Assembly Instructions

1. Install fender with fender backup plate (#1) and three 3/8" x 1-1/2" bolts (#2). Put 3/8" nylon lock nuts (#3) inside of fender and tighten.



2. Cut nylon wire tie from wiring to brake hose on main frame, (used for shipping purposes only). Fish the three wires from main unit through the hole in fender.

3. On the left side, plug in bullet plugs with white to white, black to brown and yellow to red. On the right side, plug white to white, black to brown and green to red.



4. With a pliers, install two wire clamps on fender. From rear of fender lip, install one clamp at 5-1/2" and one at 8".

5. Mount the mud flaps (#4) to the inside back of the fender using two 1/4" x 3/4" truss head bolts (#5) with flat washers (#6) and lock nuts (#7). Make sure the Kar Kaddy logo on the flap faces the rear.

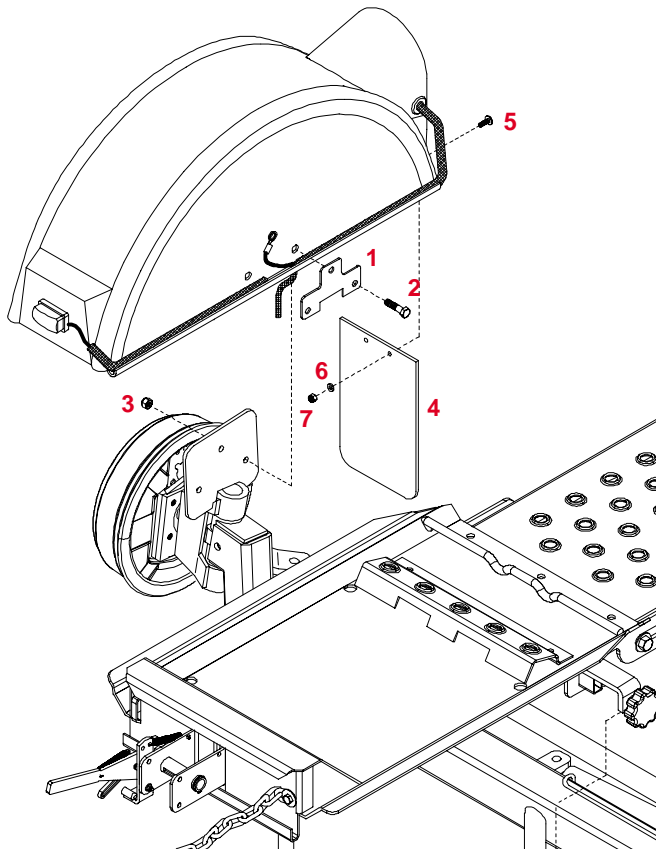

# Wiring Diagram

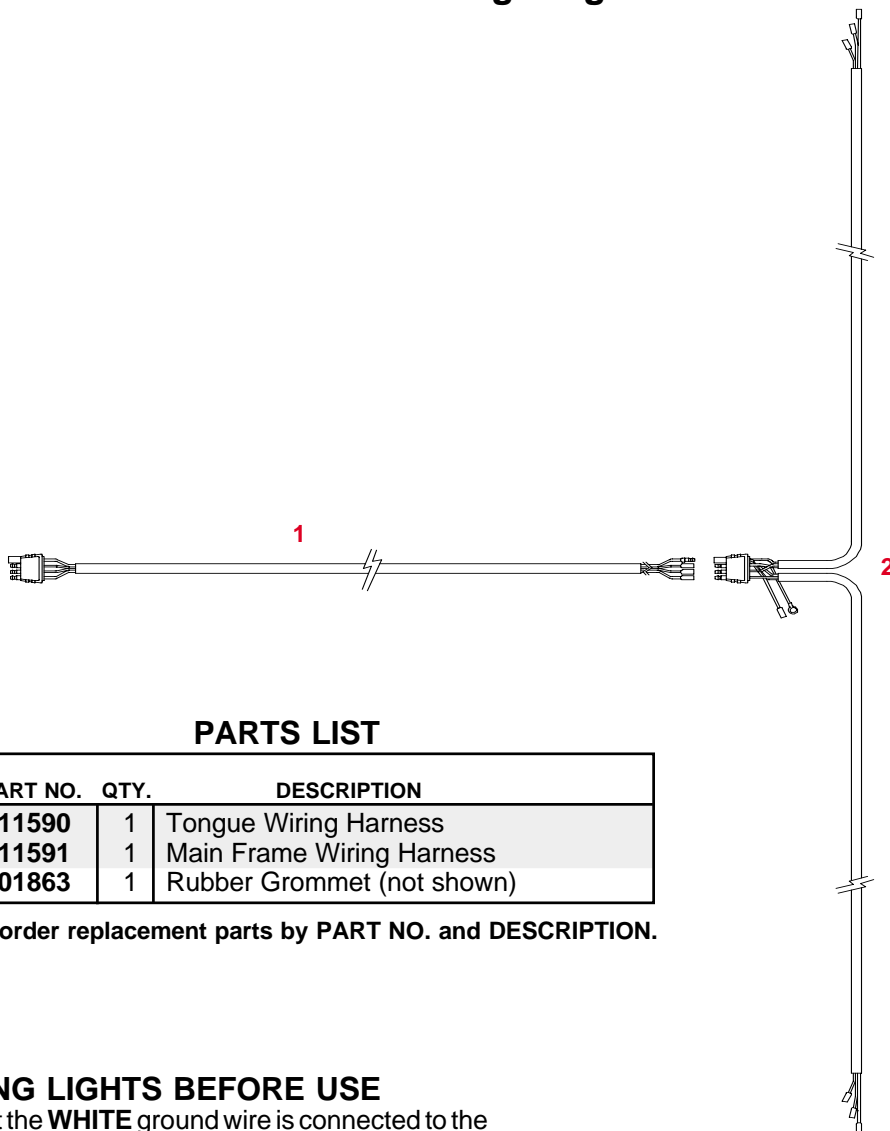

## PARTS LIST

| REF. NO. | PART NO. | QTY. | DESCRIPTION                |
|----------|----------|------|----------------------------|
| 1.       | 11590    | 1    | Tongue Wiring Harness      |
| 2.       | 11591    | 1    | Main Frame Wiring Harness  |
| 3.       | 01863    | 1    | Rubber Grommet (not shown) |

Please order replacement parts by **PART NO.** and **DESCRIPTION.**

## TESTING LIGHTS BEFORE USE

1. Make sure that the **WHITE** ground wire is connected to the frame of both the Kar Kaddy and the towing vehicle.
2. With headlights in "ON" position, the tail lights, the light cluster bar, the license plate light, and the clearance lights should be lighted.
3. Start engine and have someone depress brake pedal. Brake lights of tow dolly and towing vehicle should come "on" and "off" simultaneously with each application.
4. Turn left turn signal on. Left turn light of Kar Kaddy and towing vehicle should flash simultaneously. If turn signal light of the trailer function opposite to those of the towing vehicle, it is probable that the **YELLOW (Driver side)** and **GREEN (Passenger side)** wires have been reversed. Check the plug connection under the tongue of the Kar Kaddy to make sure wire colors are not crossed at that point. If wires are crossed change them to match color for color.

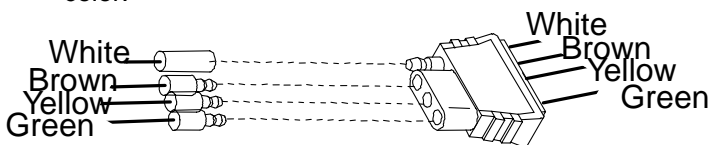

## COLOR CODE FOR WIRING HARNESS

|               |   |
|---------------|---|
| <b>WHITE</b>  | Ground  |
| <b>BROWN</b>  | Tail Lights, License Plate Lights, Light Cluster Bar & Clearance Lights |
| <b>YELLOW</b> | Left Turn and Stop  |
| <b>GREEN</b>  | Right Turn and Stop   |

## WIRING OF THE TOWING VEHICLE

Connect wiring to towing vehicle, keeping in mind the color code indicated below.

1. Make certain towing vehicle lights are **"OFF"**.
2. Connect **YELLOW** wire to left turn signal and stop wire in the left rear of towing vehicle with the wire splicer (01883) supplied.
3. Connect **GREEN** wire to the right turn signal and stop wire.
4. Connect **BROWN** wire to tail light wire.
5. **VERY IMPORTANT** - connect **WHITE** wire to frame body of towing vehicle. This is the common ground, and a clean metal - to - metal contact must be made.

**CAUTION:** Many flashers for vehicle turn signals will not carry the additional load of Kar Kaddy turn signals. If normal operation does not occur when connected to the Kar Kaddy, a heavy duty replacement flasher may be obtained through auto parts outlets.

## Tongue folding and storage

### NOTE:

Tow Dolly must be empty and unhooked to perform any and all of these steps. Do not attempt while tow dolly is loaded or hooked up.

1. Pull retainer clip from bottom of tongue locking pin. Lift locking pin out of tongue pivot.
2. With tongue wheel jack turned to its lowest position, push/pull tongue to the left.
3. Push/pull tongue until it comes to a stop by the left fender. It is recommended to place lock pin and retainer clip back in tongue pivot for storage.

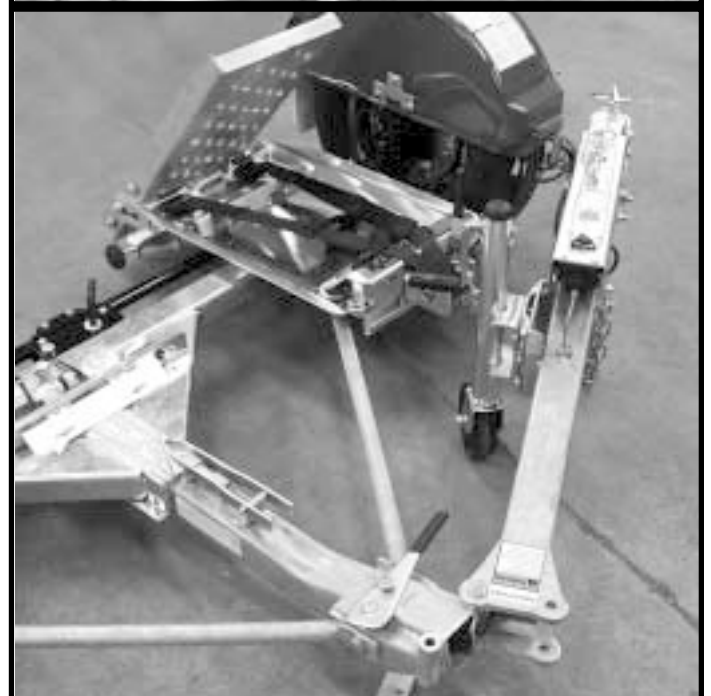
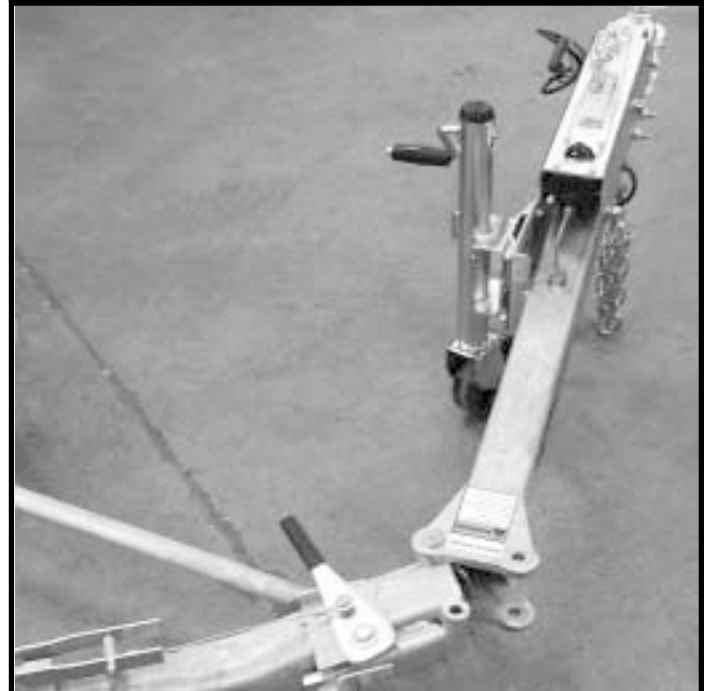

## Folding Ramp Lock

### NOTE:

Tow Dolly must be empty and unhooked to perform any and all of these steps. Do not attempt while tow dolly is loaded or hooked up.

1. Locate ramp locks at inside center of ramps.



2. Pull ramp lock straight out as far as it will go.



3. Lift ramp lock up as far as it will go and allow lock to slide in until it stops.

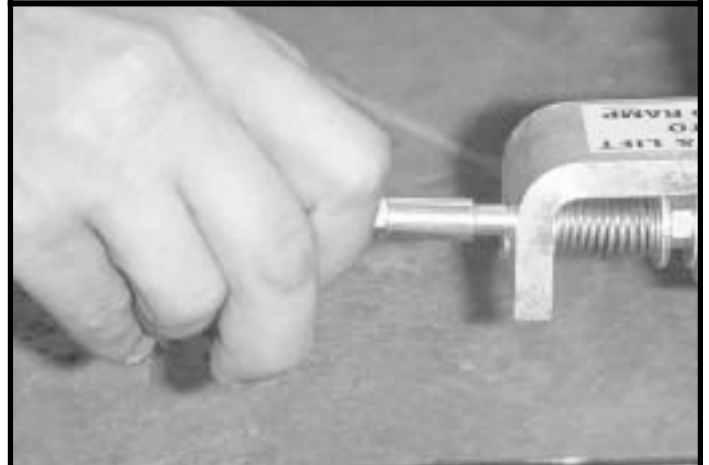

4. If lock has been pulled and lifted properly the ramp lock will extend out from it's holder. This will mean that the ramp is unlocked and ramp may be folded up.



## Folding Ramp

### NOTE:

Tow Dolly must be empty and unhooked to perform any and all of these steps. Do not attempt while tow dolly is loaded or hooked up.

1. Pull ramp back as far as it will go. Bolt must be past notch before attempting the next step.

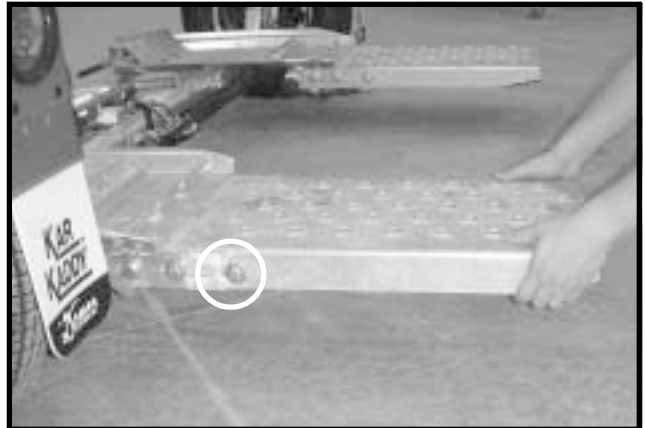

2. Lift ramp until it is past center and resting on its stops.



### IMPORTANT:

When taking this tow dolly out of storage it is very important to check all pins and retainers for damage. If damage is found replace. Do not use damaged pins or retainers. Make sure that tongue pin and retainer clip is replaced after tongue is folded back to the forward and locked position. Fold ramps down as far as they will go and push forward until you hear or see retainer handles snap into their locked positions. Check to make sure they all fully seated. Make sure that all pins and locking devices are double checked before returning this unit to service.

## Loading Angle Clearance Guide

### NOTE: User's responsibility for checking clearance

### IMPORTANT:

Using this guideline will reduce the chance of the towed vehicles air dam, or bottom of fascia from interfering with tow dolly platform and or tire stop. "X" must be less than  $3\frac{1}{2} \times "Y"$ .

Example: If Y measures 6"

$$3\frac{1}{2} \times 6 = 21$$

X must measure less than 21"

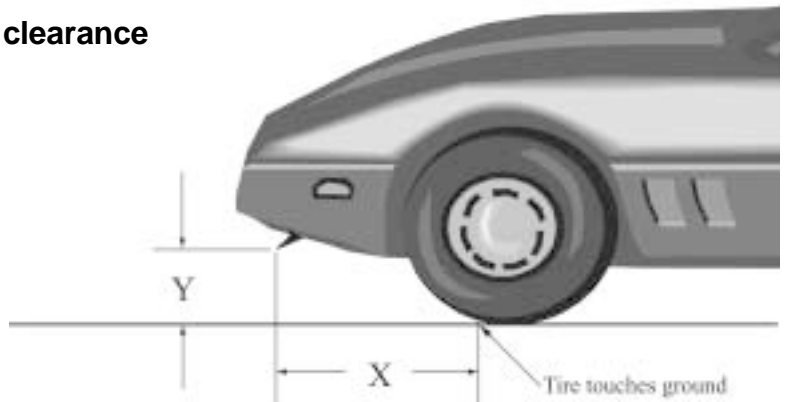

**▲ WARNING: FAILURE TO FOLLOW THESE INSTRUCTIONS CAN RESULT IN LOSS OF TOWING VEHICLE CONTROL, SEPARATION OF THE TOW DOLLY FROM THE TOWING VEHICLE, SEPARATION OF THE TOWED VEHICLE FROM THE TOW DOLLY, CAUSING SEVERE PERSONAL INJURY, DEATH, OR PROPERTY DAMAGE.**



## SAFETY

Safety is of utmost importance at all times. There are several items that must be checked each time before using and while using the Kar Kaddy.

Make sure all bolts are properly tightened and those requiring a set torque are up to specifications:

Tie Rod Castle Nut - 75 ft./lbs.

**Lug Nuts - 120 ft./lbs.**

Check Lug Nut tension after the first 5 miles and periodically thereafter.

The ball hitch must latch securely around the ball and the safety lock pin or lever must be in position to lock the hitch on the ball.

**RECOMMENDED BALL HEIGHT: 18 inches to the top of the ball on the towing vehicle.**

Hook the towed vehicle safety chains to the frame of the vehicle directly above the area where the chain is mounted on the Kar Kaddy. Leave some slack in the chain to allow suspension movement.

Check to make sure that all lights are in proper working order.

Examine the winches and straps, making sure they are in good condition.

Be certain the safety lock pins are locking the strap winches.

Retighten straps over the tires after the first 5 miles and every 50 miles thereafter. Ensure that they are tight.

The Kar-Kaddy tires must be inflated to the recommended 50 PSI.

The strap on the optional tongue winch must be in good condition and should be stored neatly on winch when not in use.

**NOTE:** The winch strap must not be left connected to the towed vehicle after it is loaded and strapped down.

Make sure the optional light bar is fastened securely at the rear of the towed vehicle.

The wires to the optional light bar should be run along the car and fastened so as not to damage the finish of the towed vehicle.

**NOTE:** This unit cannot be backed up, when loaded or with the steering lock pin removed.

All vehicles mounted on the Kar Kaddy must be mounted with the front of the vehicle facing forward.

**Rear Wheel Drive:** Disconnect the towed vehicle driveshaft for rear wheel drive vehicles with automatic transmission.

**For manual transmission:** Consult your vehicle owners manual for towing suitability with the drive shaft connected.

## MAINTENANCE

Periodically check all bolts and nuts to insure proper tension or torque.

**Grease the king pin and tie rod end grease zerks every 2500 miles.**

An occasional drop of oil may be required on the moving parts of the tie down winches.

A light film of oil should periodically be applied to steering stabilizer arm to prevent rust.

**NOTE: Proper toe-in is 1/32". This is preset at the factory.**

The operator should periodically have the toe-in checked and adjusted if needed at a qualified alignment shop. Improper toe-in can result in irregular tire wear.

### Wheel:

This tow dolly comes equipped with chrome wheels. To maintain a high gloss to the chrome, clean and wax with a soft cloth regularly. Do not use an abrasive to clean chrome, this will cause scratches and this will lead to rust.

## IMPORTANT LOADING INSTRUCTION

### **Check your wheel tie-down straps.**

Your Kar Kaddy is equipped with custom made wheel tie-down straps of a standard size that will fit most tires, however if your tires are too large or too small you will want to exchange these new straps for the proper size straps.

- 1. Tire too large** - This is very obvious the strap will not basket over the tire properly, call us, we will provide at NO Charge on an exchange basis, the proper size strap. You must return your new unused straps and provide us with the Make and Model car and the tire size.
- 2. Tire too small** - This is not as obvious, the basket will fit down over the tire very well, the problems cannot be readily seen. You must tighten the straps down solid and then check on the inside of the tire and be sure the strap, when tightened does not come in contact with any metal that may cause wear or cutting such as strut mounts. If there is contact, you need a smaller strap, call us, we will provide on a NO Charge, exchange basis, the proper size strap. You must return your new unused straps and provide us with the Make and Model car and tire size.

Thank you for Purchasing *Demo* Products.



## LOADING INSTRUCTIONS



**Step 1.** Secure ball coupler to 2" (5,000 lb. capacity) towing vehicle ball only. Make sure that the hitch and the hitch ball are in good condition and not rusted, loose or stripped. **Recommended ball height is 18" to the top of the ball.** Make sure hitch is locked down and secured with safety clip. Criss-cross safety chains under tongue and secure to towing vehicle frame.



**Step 2.** Remove black locking pin **BEFORE** loading vehicle onto the Kar Kaddy. The removal of the locking pin allows "Auto Steer" to operate. When towing the dolly empty, this pin must be in place.



**Step 4.** Before loading (and unloading) towed vehicle make sure platform and towed vehicle are in straight alignment. Tow dolly must be completely and properly hooked up to the towing vehicle. **Towing vehicle must be larger and at least 1000 lbs. heavier than the tow dolly and towed vehicle combined.**

**IMPORTANT:** Over all width of towed vehicle must not exceed:

76" max. (outside to outside),  
42" min. (inside to inside),  
78" max. (body width).



**Step 3.** Loosen wing nut on back of license plate holder, turn the clip on the front to a horizontal position and put license in the "down" position. Turn the clip back so it rests against the back of the light bar to hold the license down and tighten wing nut. **(License must be "UP" with the tow dolly empty).**

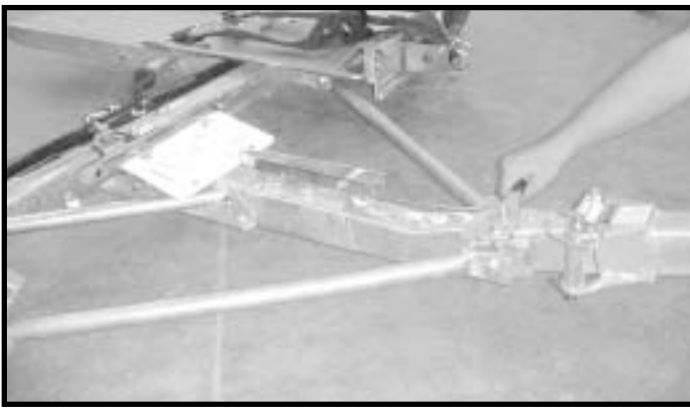

**Step 5.** Grasp bed release handle on tongue and pull toward coupler. This releases the tilt bed to permit loading.



**Step 6.** With someone safely guiding you, slowly drive vehicle onto platform **FRONT FORWARD**. (Any vehicle mounted on tow dolly must be mounted with front of the vehicle facing forward.) Drive the car forward until the tires touch the ramps. Make sure the tire is aligned to ascend onto the ramps.



**Step 7.** Drive vehicle onto the platform - **front forward** - until tires touch the wheel stops at the front of each side of the platform and the platform tilts to a flat position. Make sure the car is centered on the platform. Towed vehicle tires must fit in wheel troughs without overhanging sides. Engage towed vehicle parking brake. **Shift loaded car into "park" and lock steering wheel with front tires in a straight position. If the car does not have a locking steering column the steering wheel must be tied securely with front tires in a straight position.**

**Rear Wheel Drive:** Disconnect towed vehicle driveshaft for rear wheel drive vehicles with automatic transmission.

**For manual transmission:** Consult your vehicle owners manual for towing suitability with the drive shaft connected.

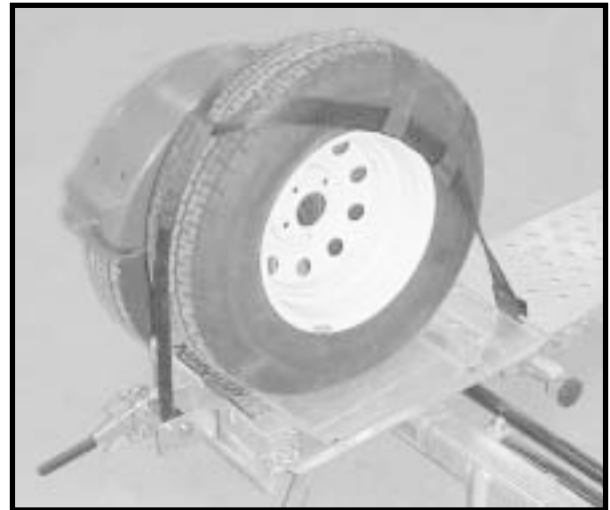

**Step 8.** Place one tie-down strap over each tire and secure hooks to rods located at the rear of each wheel platform. The short side of the hook must face the rear of the Kar Kaddy.



**Step 9.** Be sure tie-down winch is centered with the tire before tightening straps.

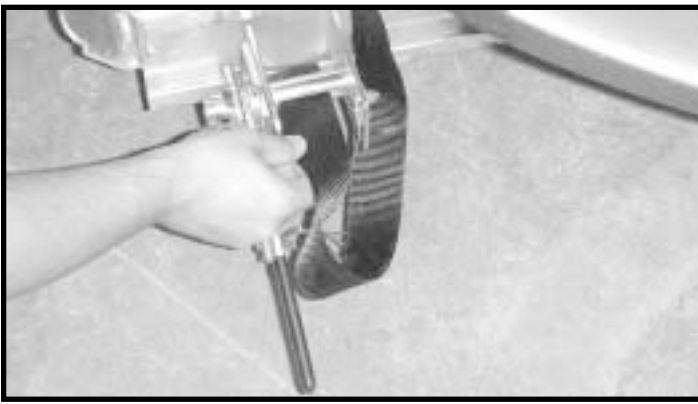

**Step 10.** Thread tie-down strap through the slotted tube on the tie-down winch. Pull approx. 6" of strap through this slot. Begin tightening strap making sure the tail becomes enclosed by the strap coming over the tire. Tighten the straps ensuring that the strap fed through the slot binds between the shaft and the strap being wound onto the winch shaft. While tightening straps, pull cross strap forward to ensure even tightening. **NOTE: Be sure to tighten straps until each tire starts to flatten against tire stop.** After each strap is tight, insert a safety pin in each winch. **Disengage towed vehicle parking brake.**

**Straps must be retightened after first 5 miles of travel. Check straps every 50 miles thereafter to ensure they are tight and not rubbing or fraying.**

**Step 11.** Make sure the tie-down strap is the correct size for the auto tire. See page 4 of this instruction for proper fit and exchange instructions.



**Step 12.** Hook the towed vehicle safety chains to frame of vehicle directly above the area where the chains are mounted on the Kar Kaddy. Leave some slack in the chains to allow suspension movement of the towed vehicle.

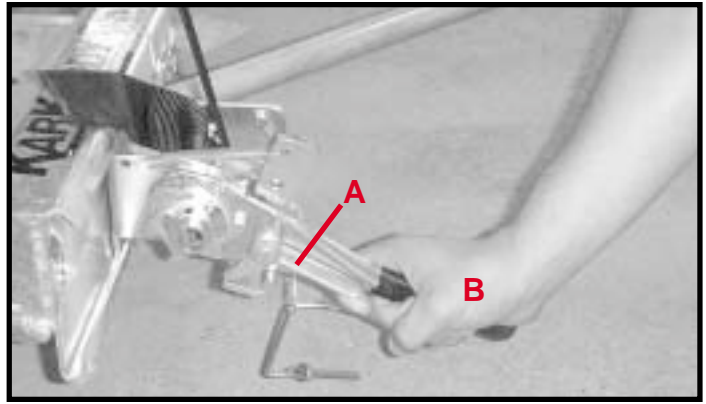

**Step 13.** TO UNLOAD towed vehicle. **Never unhook tow dolly coupler from towing vehicle, before unloading todolly.** Make sure that platform and vehicle are straight. Reinstall driveshaft. Ensure that towed vehicle parking brake is fully engaged, then unhook the towed vehicle safety chains, and release the tie-down straps. **NOTE:** Tie down straps must be "quick -released" by grasping ratchet pawl (A) and ratchet handle (B) simultaneously and pushing down sharply. This process will permit easy removal of strap from winch. Grasp bed release handle on tongue and pull toward coupler. This releases the tilt bed to permit unloading. This will allow the platform to tilt as you slowly drive off. Make sure the winch ratchet handles are horizontal. Replace the "Auto Steer" locking pin (for towing empty).

**Step 14.** To pull the Kar Kaddy empty, make sure "Auto-Steer" LOCKING PIN IS IN PLACE and towing vehicle safety chains are up and hooked. Tie-down winch handles should be left in a down position (horizontal position) with safety pins in place when towing loaded or empty. **DO NOT ATTEMPT TO PULL KAR KADDY WITH WHEEL PLATFORM IN LOADING (tilted) POSITION.**

## DAMAGE PREVENTION

Check your vehicle manual or registration for vehicle weight. Towing vehicle must be larger and at least 1,000 lbs. heavier than the towed vehicle and tow dolly combined.

Do not pack goods in car that is being towed. Overloading the Kar Kaddy or exceeding the width limit may result in damage to both car and Kar Kaddy.

## REAR WHEEL DRIVE PRECAUTIONS

Disconnect towed vehicle driveshaft for rear wheel drive vehicles with automatic transmission. Simply placing transmission in neutral is not sufficient to prevent damage to transmission.

For manual transmission: Consult your vehicle owners manual for towing suitability with the drive shaft connected. **ALL VEHICLES MOUNTED ON THE KAR KADDY MUST BE WITH THE FRONT OF THE VEHICLE FACING FORWARD.**

## SAFETY

- Examine winches and straps to make sure they are in good condition.
- Check wheel nuts every trip.
- Tires must be inflated to recommended pressure by tire manufacturer.
- Be certain the safety lock pins lock the strap winches.
- Retighten the straps over the tires after the first 5 miles of travel. Check straps every 50 miles there after to ensure they are tight and not rubbing or fraying.

# KAR-KADDY TOE-IN ADJUSTMENT

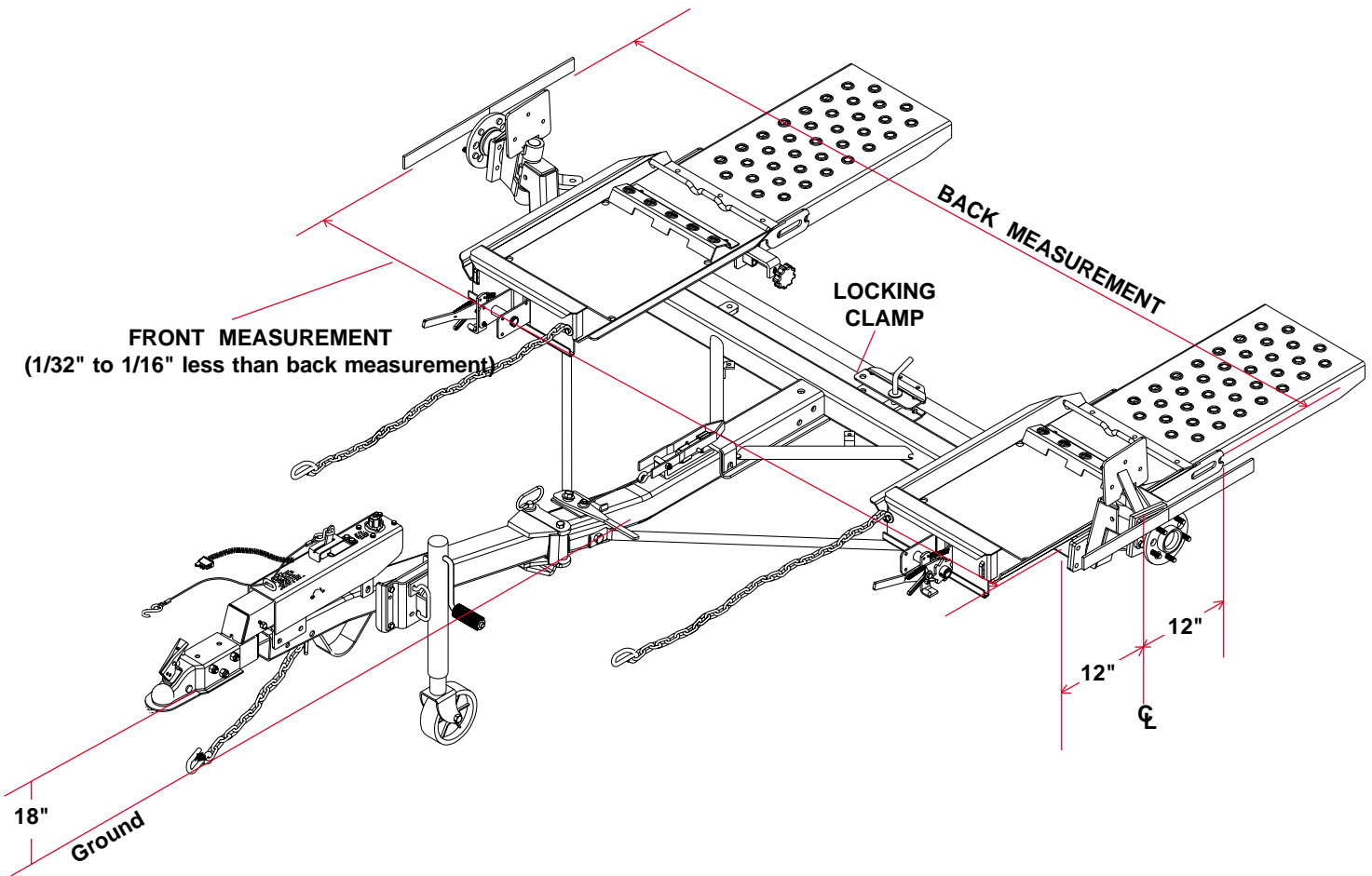

## MEASURING THE TOE-IN

Have the tongue in a "hooked-up" position with the ball coupler 18" off the ground. Jack up the axle just enough to allow you to take the wheels off and put blocks under the axle. Take the wheels off.

Find two 24" long bars. These could be a level, a square or a straight piece of iron bar. Clamp one bar tight to the face of each hub/Brake Drum with 12" extending forward and backward of the center of the spindle. The bars must be parallel to the platform the car sits on. Measure across the back end of the bars and then across the front end. The front measurement should be 1/32" to 1/16" less than the back measurement. If the unit needs to be adjusted, this must be done by adjusting the tie rod.

## TOE-IN ADJUSTMENT

1. Put a mark on each side of the locking clamp on the tie rod.
2. Loosen the locking nuts on each end of the tie rod and then the six bolts on the tie rod locking clamp.
3. Turn the tie rod whichever direction is needed until you have a front measurement of 1/32" to 1/16" less than the back measurement.
4. Hold the tie rod and tighten the locknuts on each end.
5. Measure again to make sure the toe-in measurement has not moved.
6. Tighten the locking clamp bolts while holding clamp between the marks you previously put on the tie rod.
7. Reassemble the rest of the Kar Kaddy unit.

# MODEL DA91 ACTUATOR PARTS BREAKDOWN

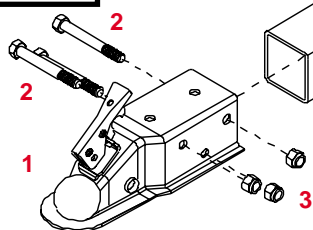
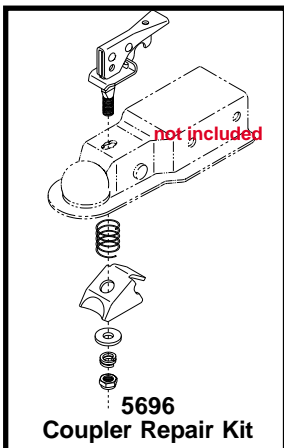
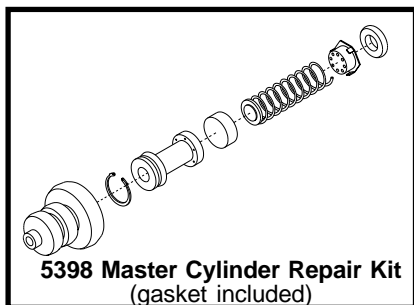

**2" Lever Lock Coupler**  
**RATED AT 6000#**

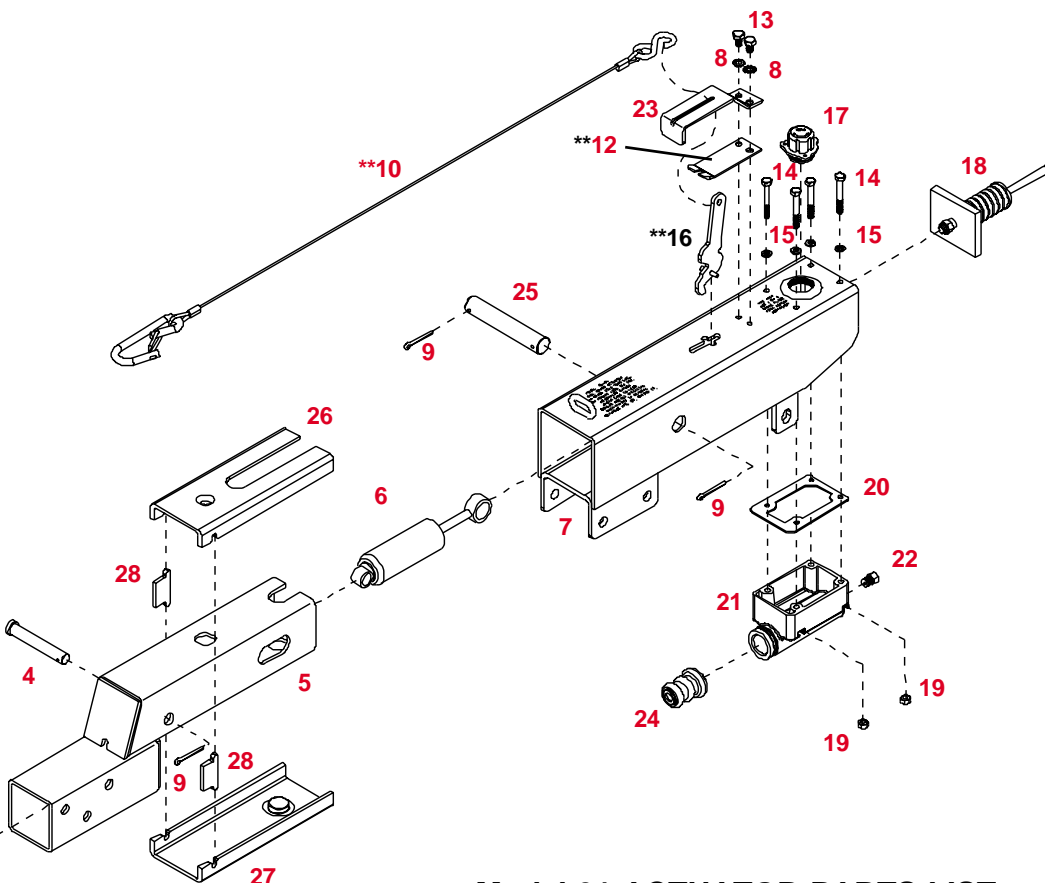

## Model 91 ACTUATOR PARTS LIST

| REF. NO. | PART NO. | QTY. | DESCRIPTION                                 |
|----------|----------|------|---|
| 1.       | 09417    | 1    | 6000# 2" Lever Lock Coupler (zinc plated)   |
| 2.       | 01896    | 3    | 1/2"-13UNC x 4" Hex Head Bolt (gr.5)        |
| 3.       | 02178    | 3    | 1/2"-13UNC Nylon Insert Lock Nut            |
| 4.       | 05426    | 1    | Front Shock Pin (drop tube actuators)       |
| 5.       | 11079-95 | 1    | Drop Tube Actuator Slider (plated)          |
| 6.       | SB12426  | 1    | Damper/ Shock                               |
| 7.       | 11164-95 | 1    | 3 Bolt Mount Outer Case (plated)            |
| 8.       | 05424    | 2    | 5/16" External Tooth Lock Washer            |
| 9.       | 02363    | 2    | 5/32" x 1 1/4 Cotter Pin(Qty 3 w/drop tube) |
| **10.    | 05408    | 1    | 3/32" Cable with hooks                      |
| **12.    | 05693-95 | 1    | Emergency Lever Spring (plated)             |
| 13.      | 05961    | 2    | 5/16"-18UNC x 5/8" Hex Head Bolt (gr.5)     |
| 14.      | 00618    | 4    | 1/4"-20UNC x 2" Hex Head Bolt (gr.5)        |
| 15.      | 00057    | 4    | 1/4" Lock Washer                            |
| **16.    | 05951    | 1    | Emergency Lever Assembly                    |
| 17.      | 03876    | 1    | Master Cylinder Cap w/ Diaphragm & O-ring   |
| -        | 05849    | 1    | O-Ring Only (not shown)                     |
| 18.      | 05977    | 1    | Push Rod Assembly                           |
| 19.      | 00062    | 4    | 1/4"-20 UNC Hex Nut                         |
| 20.      | 09153    | -    | Plastic Master Cyl. Gasket ONLY             |
| 21.      | 10616    | 1    | Master Cylinder                             |
| 22.      | SB12098  | 1    | .018 Connector Orifice (Drum Brakes)        |
| 23.      | 03866-95 | 1    | Lever Guide (plated)                        |
| 24.      | 05687    | 1    | Master Cylinder Protective Boot             |
| 25.      | 05986-95 | 1    | Connecting Pin (plated)                     |
| 26.      | 10965    | 1    | Upper Slider                                |
| 27.      | 10966    | 1    | Lower Slider                                |
| 28.      | 10967    | 2    | Side Spacers                                |
| -        | 5401     | -    | Lever Replacement Kit (incl. items w/**)    |
| -        | 5650     | -    | Master Cyl. Replacement Kit (drum)          |
| -        | 5696     | -    | Coupler Repair Kit                          |

Please order replacement parts by **PART NO.** and **DESCRIPTION**

### BLEEDING THE SYSTEM

The first requirement for safe, sure hydraulic braking is the use of quality brake fluid. Use only DOT-3 or DOT-4 brake fluid from a sealed container.

If pressure bleeding equipment is available, follow the manufacturer's instruction in bleeding the system.

**If system must be bled manually, proceed as follows:** Fill master cylinder with fluid. Install bleeder hose on first wheel cylinder to be bled.

Have loose end of hose submerged in brake fluid in glass container to observe bubbling.

By loosening the bleeder screw located in the wheel cylinder one turn, the system is open to the atmosphere through the passage drilled in the screw. Pump actuator with long steady strokes. The bleeding operation is completed when bubbles no longer rise to the surface of the fluid. **Be sure to close bleeder screw securely.**

Repeat bleeding operation at each wheel cylinder. During the bleeding process, replenish the brake fluid, so the level does not fall below the 1/2 full level in the master cylinder reservoir. After bleeding is complete, make sure master cylinder reservoir is filled and filler cap is securely in place.

After the bleeding operation has been completed, apply pressure to the system and check the whole brake system for leaks.

# 10" SELF-ADJUSTING BRAKE CLUSTER and DRUM PARTS BREAKDOWN

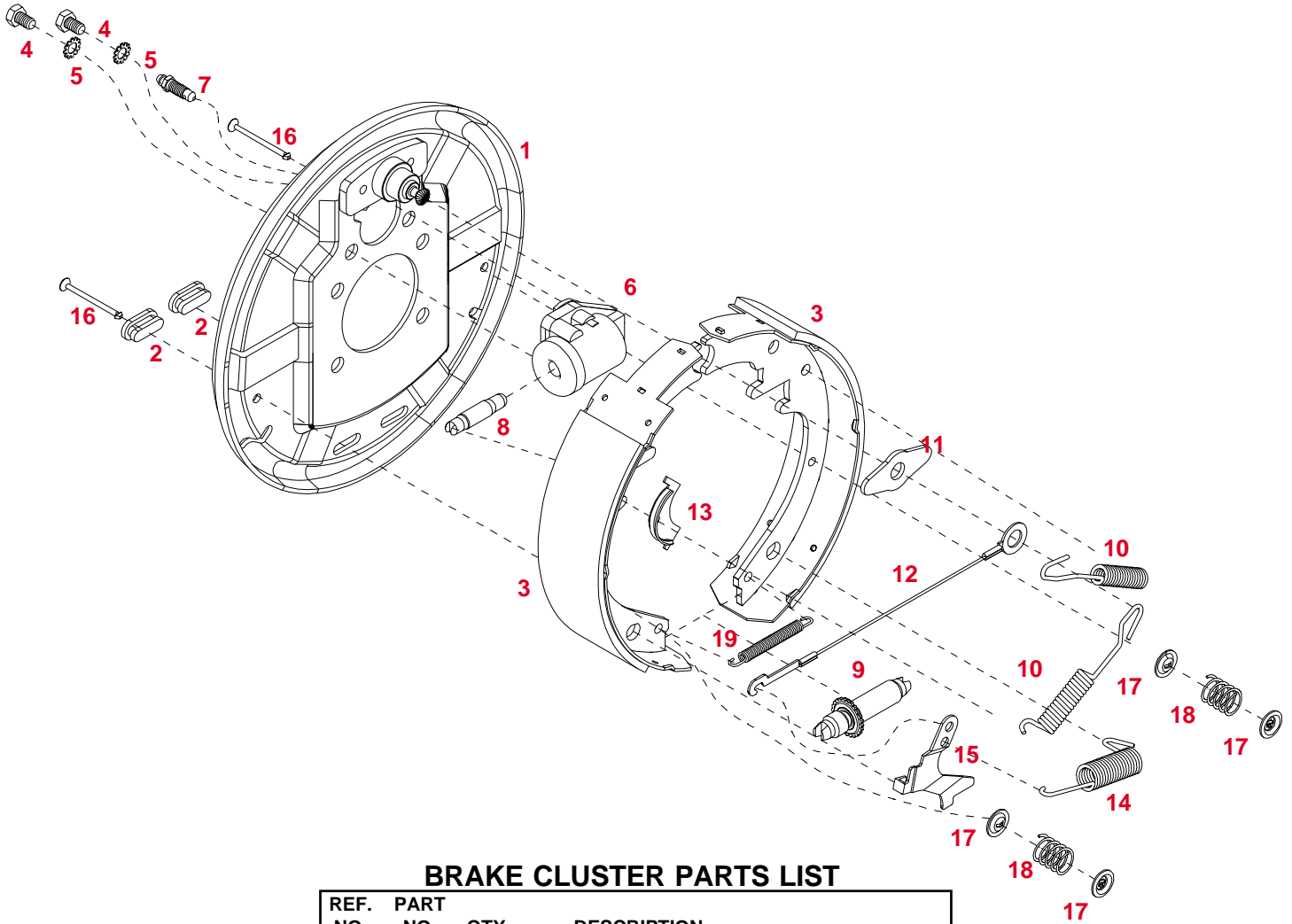

## BRAKE CLUSTER PARTS LIST

| REF. NO. | PART NO.          | QTY. | DESCRIPTION   |
|----------|-------------------|------|---|
| -        | <b>SB24429M</b>   | -    | <b>Left Hand Cluster</b> (shown above)                              |
| -        | <b>SB24428M</b>   | -    | <b>Right Hand Cluster</b>   |
| 1.       | <b>SB23871</b>    | 1    | Back Plate Assembly   |
| 2.       | <b>SB9254</b>     | 2    | Cover Plate - Adjusting Hole  |
| 3.       | <b>SB10954</b>    | 1    | Brake Shoe Kit (includes 2 Primary & 2 Secondary)                   |
| 4.       | <b>04305</b>      | 2    | 5/16"-18UNC-Gr5 x 1/2" Hex Hd Bolt                                  |
| 5.       | <b>05424</b>      | 2    | 5/16" External Tooth Washer   |
| 6.       | <b>SB9776</b>     | 1    | Wheel Cylinder Assembly - Right                                     |
| -        | <b>SB9777</b>     | 1    | Wheel Cylinder Assembly - Left                                      |
| 7.       | <b>05431</b>      | 1    | Bleeder - replacement   |
| 8.       | <b>SB9783</b>     | 1    | Push Rod  |
| 9.       | <b>SB24047</b>    | 1    | Adjusting Screw Assembly - "R" (for LEFT cluster)                   |
| -        | <b>SB24048</b>    | 1    | Adjusting Screw Assembly - "L" (for RIGHT cluster)                  |
| 10.      | <b>SB10958</b>    | 2    | Spring - Shoe   |
| 11.      | <b>SB10961-95</b> | 1    | Shoe Guide  |
| 12.      | <b>SB23937</b>    | 1    | Cable   |
| 13.      | <b>SB23936</b>    | 1    | Cable Guide   |
| 14.      | <b>SB23724</b>    | 1    | Spring - Adjusting Screw  |
| 15.      | <b>05415-95</b>   | 1    | Lever - Right   |
| -        | <b>05414-95</b>   | 1    | Lever - Left  |
| 16.      | <b>SB10959</b>    | 2    | Pin - Shoe Hold Down  |
| 17.      | <b>SB9789</b>     | 4    | Cup Shoe Hold Down  |
| 18.      | <b>05983</b>      | 2    | Spring - Shoe Hold Down   |
| 19.      | <b>03380</b>      | 1    | Spring  |
| -        | <b>SB15845</b>    | 1    | <b>Wheel Cylinder Repair Kit</b><br>(includes spring, cup and boot) |
| -        | <b>SB40929</b>    | 2    | <b>10" Brake Drum</b>   |

Please order replacement parts by **PART NO.** and **DESCRIPTION.**  
Brake shoe kit can be ordered for one complete axle only.

# SURGE BRAKES PARTS BREAKDOWN

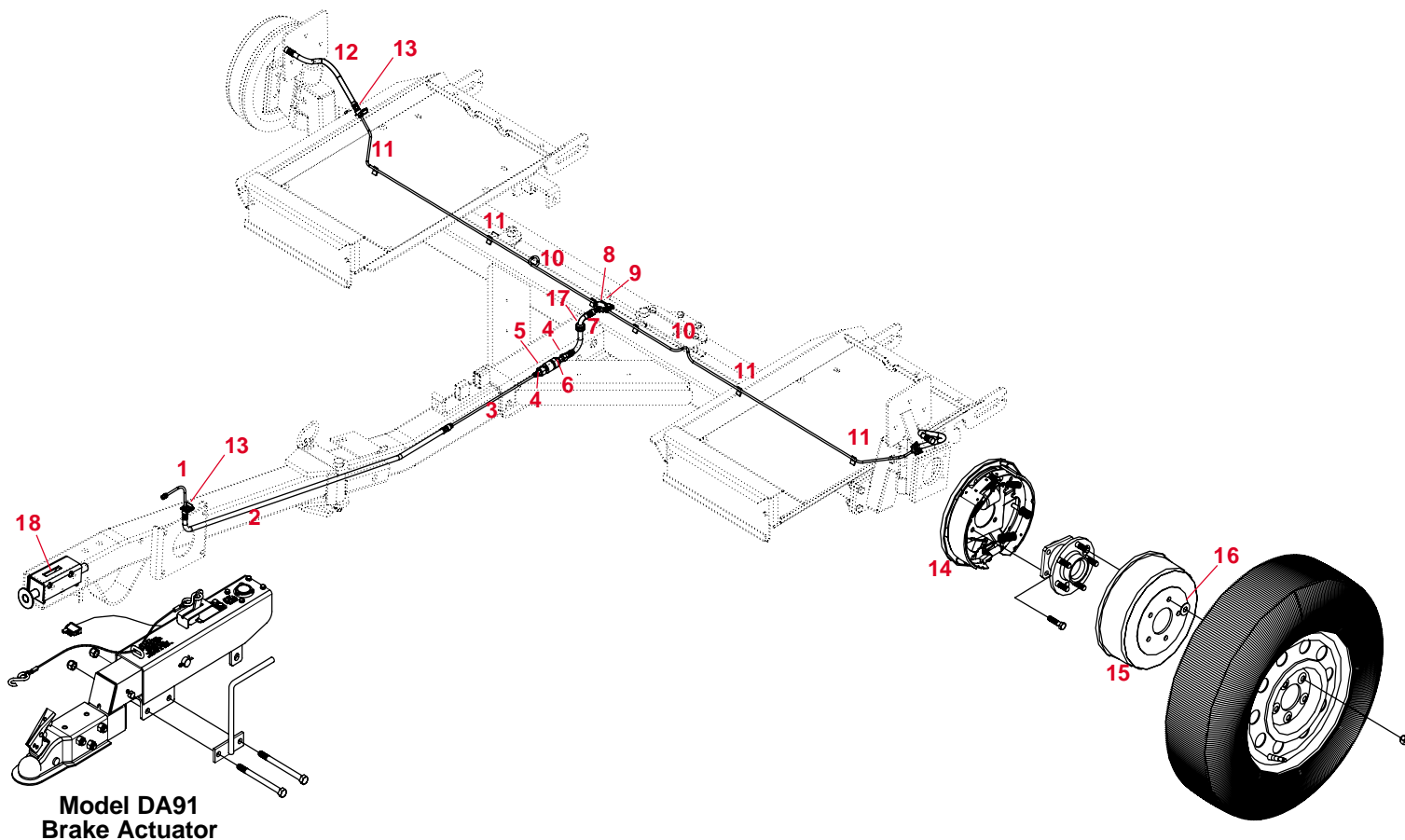

## SURGE BRAKES FIELD SETUP PARTS LIST

| REF. NO. | PART NO. | QTY. | DESCRIPTION                          |
|----------|----------|------|--------------------------------------|
| 1.       | 11968    | 1    | 6" Brake Line                        |
| 2.       | 02034    | 1    | 45" Brake Hose                       |
| 3.       | SB512    | 1    | 12" Brake Line                       |
| 4.       | 05679    | 2    | Brake Fitting                        |
| 5.       | 11617    | 1    | Male Coupler                         |
| 6.       | 11618    | 1    | Female Coupler                       |
| 7.       | 11643    | 1    | 7" Brake Hose Swival Male/Solid Male |
| 8.       | SB7785   | 1    | Brake Line Tee                       |
| 9.       | 05960    | 1    | 5/16" x 1/2" Self-threading Bolt     |
| 10.      | SB541    | 2    | 41" Brake Line                       |
| 11.      | 02549    | 6    | Rubber Protector                     |
| 12.      | 02032    | 2    | 12" Brake Hose                       |
| 13.      | SB7764   | 3    | Brake Line Clip                      |
| 14.      | SB24429  | 1    | Left Brake Cluster                   |
| --       | SB24428  | 1    | Right Brake Cluster                  |
| 15.      | SB40929  | 2    | 10" Brake Drum                       |
| 16.      | 04174    | 4    | Retainer Washer                      |
| 17.      | 01863    | 1    | Rubber Grommet                       |
| 18.      | 12445-30 | 1    | Spring Return System                 |

Please order replacement parts by **PART NO.** and **DESCRIPTION.**

## SURGE BRAKES FACTORY SETUP PARTS LIST

| REF. NO. | PART NO. | QTY. | DESCRIPTION                             |
|----------|----------|------|---|
| 1.       | 11968    | 1    | 6" Brake Line                           |
| 2.       | 02034    | 1    | 45" Brake Hose                          |
| 3.       | 12449    | 1    | 15" Brake Line                          |
| 4.       | N/A      | 2    | Brake Fitting                           |
| 5.       | N/A      | 1    | Male Coupler                            |
| 6.       | N/A      | 1    | Female Coupler                          |
| 7.       | SB7H67   | 1    | 7" Brake Hose, Swival Male/Solid Female |
| 8.       | SB7785   | 1    | Brake Line Tee                          |
| 9.       | 05960    | 1    | 5/16" x 1/2" Self-threading Bolt        |
| 10.      | SB541    | 2    | 41" Brake Line                          |
| 11.      | 02549    | 6    | Rubber Protector                        |
| 12.      | 02032    | 2    | 12" Brake Hose                          |
| 13.      | SB7764   | 3    | Brake Line Clip                         |
| 14.      | SB24429  | 1    | Left Brake Cluster                      |
| --       | SB24428  | 1    | Right Brake Cluster                     |
| 15.      | SB40929  | 2    | 10" Brake Drum                          |
| 16.      | 04174    | 4    | Retainer Washer                         |
| 17.      | 01863    | 1    | Rubber Grommet                          |
| 18.      | 12445-30 | 1    | Spring Return System                    |

Please order replacement parts by **PART NO.** and **DESCRIPTION.**

## BLEEDING THE SYSTEM

The first requirement for safe, sure hydraulic braking is the use of quality brake fluid. Use only DOT-3 or DOT-4 brake fluid from a sealed container.

Only use pressure bleeding equipment and follow the manufacturer's instruction in bleeding the system.

# KK460SS PARTS BREAKDOWN

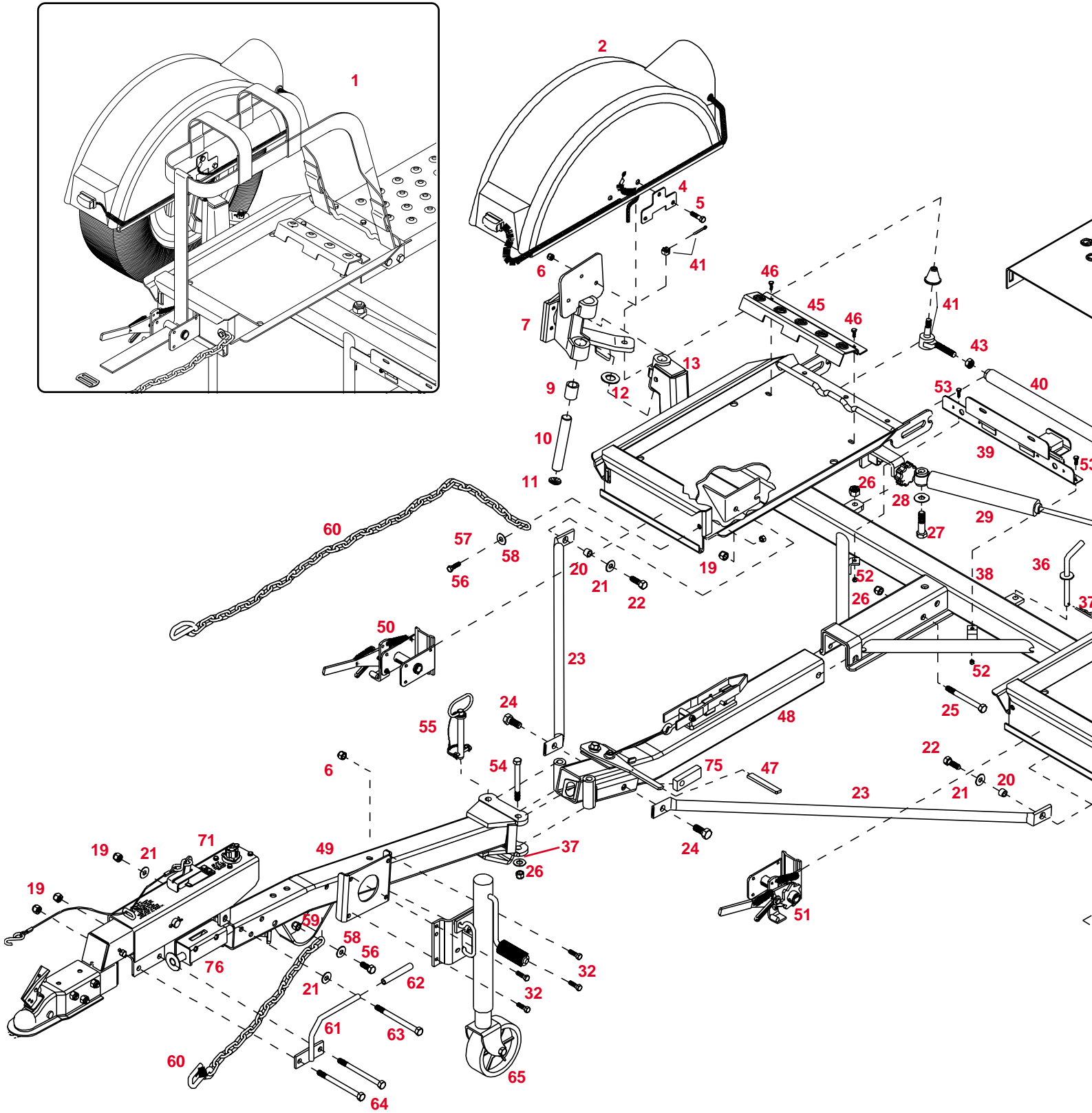



| REF. NO. | PART NO. | QTY. | DESCRIPTION                                       |
|----------|----------|------|---|
| 1.       | 03528    | 2    | Tie-down Strap assembly, Black                    |
| 2.       | 5737     | 1    | Right Fender Assembly with Lights                 |
| 3.       | 5736     | 1    | Left Fender Assembly with Lights                  |
| 4.       | 04424-95 | 2    | Fender Backing Plate                              |
| 5.       | 00914    | 6    | 3/8"-16UNC x 1-1/2" Hex Head Bolt (gr.5)          |
| 6.       | 02592    | 18   | 3/8"-16UNC Nylon Lock Nut                         |
| 7.       | 04165-80 | 1    | Right Wheel Carrier                               |
| 8.       | 04166-80 | 1    | Left Wheel Carrier                                |
| 9.       | 01732    | 4    | 1" I.D. x 1-1/4" O.D. x 1-1/2" lg. Bushing (brnz) |
| 10.      | 11588    | 2    | King Pin (1" x 6-1/2")                            |

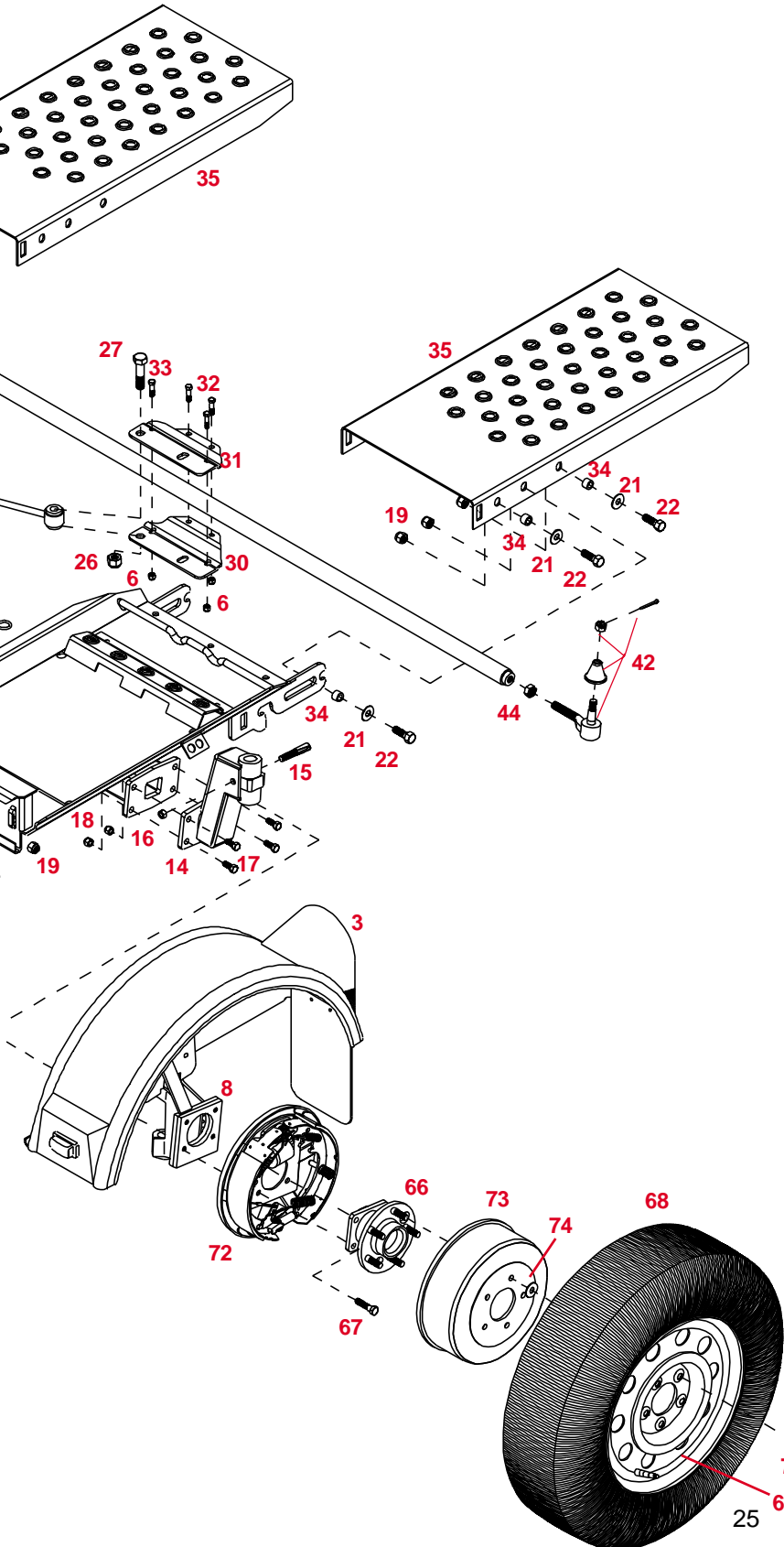

| REF. NO. | PART NO.   | QTY. | DESCRIPTION   |
|----------|------------|------|---|
| 11.      | 01731      | 4    | 1-1/4" Dust Cap                                     |
| 12.      | 05587      | 2    | 1" I.D.x 14 GA Narrow Rim Machine Washer            |
| 13.      | 11566-80   | 1    | Right Drop Axle Mount                               |
| 14.      | 11550-80   | 1    | Left Drop Axle Mount                                |
| 15.      | 11551      | 2    | King Pin Retainer Bolt                              |
| 16.      | 03724      | 2    | 7/16"-20UNF Center Punched Nut                      |
| 17.      | 02377      | 8    | 7/16"-20UNF x 1-1/2" Epoxy Bolt (gr.8)              |
| 18.      | 04168      | 8    | 7/16"-20UNF Nylon Lock Nut                          |
| 19.      | 02178      | 18   | 1/2"-13UNC Nylon Lock Nut                           |
| 20.      | 02579-95   | 2    | Pivot Bushing                                       |
| 21.      | 00085      | 15   | 1/2" Flatwasher                                     |
| 22.      | 01254      | 15   | 1/2"-13UNC x 1-1/2" Hex Head Bolt (gr.5)            |
| 23.      | 02747-96   | 2    | Bracing Strut                                       |
| 24.      | 03503      | 2    | 5/8"-11UNC x 1-1/4" Epoxy Bolt (gr.5)               |
| 25.      | 02434      | 1    | 5/8"-13UNC x 4-1/2" Hex Head Bolt (gr.5)            |
| 26.      | 02587      | 4    | 5/8"-13UNC Nylon Lock Nut                           |
| 27.      | 02696      | 2    | 5/8"-11UNC x 2-3/4" lg. Hex Head Bolt (gr.5)        |
| 28.      | 00477      | 1    | 5/8" Flatwasher                                     |
| 29.      | 01729-30   | 1    | Steering Stabilizer Shock                           |
| 30.      | 11553-80   | 1    | Tie Rod Clamp, Bottom                               |
| 31.      | 11554-80   | 1    | Tie Rod Clamp, Top                                  |
| 32.      | 00907      | 6    | 3/8"-16UNC x 1" Hex Head Bolt (gr.5)                |
| 33.      | 02494      | 2    | 3/8"-16UNC x 2-1/4" Hex Head Bolt (gr.5)            |
| 34.      | 11659-91   | 12   | Ramp Bushing  |
| 35.      | 11529-96   | 2    | Ramp  |
| 36.      | 01718-95   | 1    | Tie Rod Locking Pin                                 |
| -        | 02189      | 1    | Replacement Black Handle Grip for Locking Pin       |
| 37.      | 00182      | 1    | Hair pin  |
| 38.      | 11540-96   | 1    | KK460SS Main Frame                                  |
| 39.      | 5740       | 1    | License Plate Bracket Assembly                      |
| 40.      | 04771-80   | 1    | Tie Rod   |
| 41.      | 5179       | 1    | Right Tie Rod End w/Right Hand Threads              |
| 42.      | 5178       | 1    | Left Side Tie Rod End with Left Hand Threads        |
| 43.      | 01905      | 1    | 9/16"-18UNF Jam Nut w/Right Hand Threads            |
| 44.      | 01904      | 1    | 9/16"-18UNF Jam Nut w/Left Hand Threads             |
| 45.      | 04773-96   | 2    | Rear tire Stop                                      |
| 46.      | 00523      | 4    | 3/8"-16UNC x 1-1/4" lg. Hex Head Bolt (gr.5)        |
| 47.      | 02243      | 1    | Black Vinyl Hand Grip                               |
| 48.      | 11978-96   | 1    | Rear Tongue Half                                    |
| 49.      | 11969-96   | 1    | Front Tongue Half                                   |
| 50.      | 5433       | 1    | Right Winch assembly                                |
| 51.      | 5432       | 1    | Left Winch Assembly                                 |
| 52.      | 02772      | 2    | 1/4"-20UNC Nylon Lock Nut                           |
| 53.      | 04176      | 2    | 1/4"-20UNC x 3/4" Carriage Bolt                     |
| 54.      | 11967-95   | 1    | 5/8"-13UNC x 5 1/4" Hex Head Bolt (gr.5) Hinge Bolt |
| 55.      | 11795      | 1    | Pin, 5/8" x 4-7/8"                                  |
| 56.      | 01898      | 4    | 7/16"-14UNC x 1-1/4" Hex Head Bolt (gr.5)           |
| 57.      | 00078      | 2    | 7/16" Lockwasher                                    |
| 58.      | 00059      | 8    | 3/8" Flat Washer                                    |
| 59.      | 02771      | 2    | 7/16"-14UNC Nylon Lock Nut                          |
| 60.      | 02383      | 4    | 36" Safety Chain                                    |
| 61.      | 02288-95   | 1    | Bolt on Handle                                      |
| 62.      | 02189      | 1    | Rubber Handle Grip                                  |
| 63.      | 01338      | 1    | 1/2"-12UNC x 4-1/2" lg. Hex Head Bolt (gr.5)        |
| 64.      | 01975      | 2    | 1/2"-12UNC x 5" lg. Hex Head Bolt (gr.5)            |
| 65.      | 11683      | 1    | Wheel Jack  |
| 66.      | 04369      | 2    | Hub and Spindle                                     |
| -        | 02917      | -    | Replacement 12mm x 1.50mm Stud Bolt                 |
| 67.      | 02210      | 8    | 7/16"-20UNF x 1-1/4" Epoxy Bolt (gr.8)              |
| 68.      | 11913      | 2    | ST205/75R14 "C"Range Radial Tire                    |
| 69.      | 11574      | 2    | Rim, 14 x 5.5, 5 on 115mm B.C.                      |
| 70.      | 02933      | 10   | Chrome Lug Nut                                      |
| 71.      | 5607       | 1    | DA91 Actuator                                       |
| 72.      | SB24428    | 1    | 10" Brake Cluster, RH                               |
| -        | SB24429    | 1    | 10" Brake Cluster, LH                               |
| 73.      | SB40929-30 | 2    | 10" Brake Drum                                      |
| 74.      | 04174      | 4    | Retainer Washer                                     |
| 75.      | 11971-95   | 2    | Nut Plate   |
| 76.      | 12445-30   | 1    | Spring Return System                                |

Please order replacement parts by **PART NO.** and **DESCRIPTION.**

# WINCH ASSEMBLY

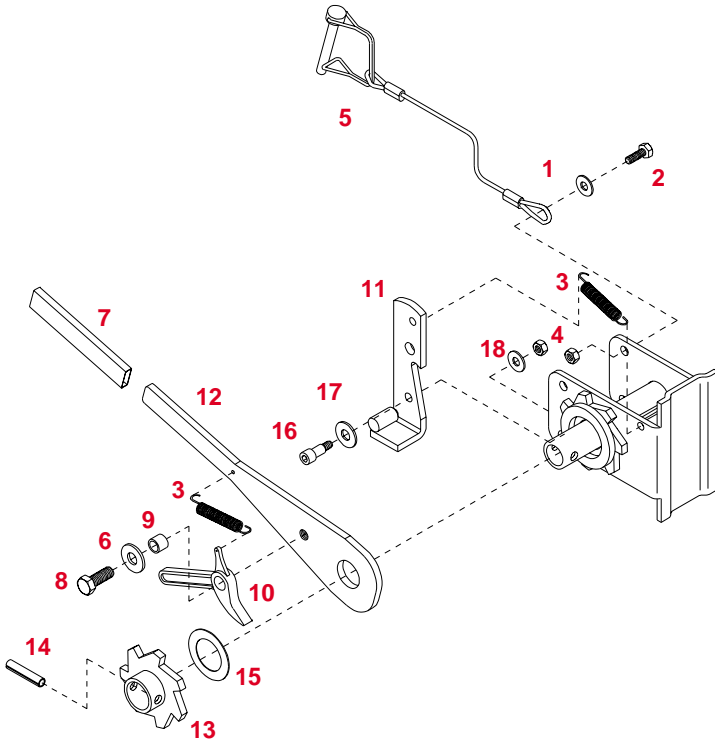

**Left Winch 5432 (Shown)  
Right Winch 5433**

|     |                 |   |   |
|-----|-----------------|---|---|
| -   | <b>5432</b>     | - | Left Winch Assembly                           |
| -   | <b>5433</b>     | - | Right Winch Assembly                          |
| 1.  | <b>00214</b>    | 1 | 1/4" Flat Washer                              |
| 2.  | <b>01076</b>    | 1 | 1/4"-20 UNC x 3/4" Hex Head Bolt              |
| 3.  | <b>01864</b>    | 2 | Spring  |
| 4.  | <b>02772</b>    | 2 | 1/4"-20 UNC Nylon Insert Locknut              |
| 5.  | <b>05337</b>    | 1 | Lock Pin w/ Cable                             |
| 6.  | <b>00004</b>    | 2 | 5/16" Flat Washer                             |
| 7.  | <b>02243</b>    | 1 | Black Vinyl Hand Grip                         |
| 8.  | <b>05444</b>    | 1 | 3/8"-16 UNC x 3/4" Hex Head Bolt w/ Epoxy     |
| 9.  | <b>05449</b>    | 1 | Winch Pawl Bushing (Stainless Steel)          |
| 10. | <b>05450</b>    | 1 | Winch Pawl                                    |
| 11. | <b>03572-95</b> | 1 | Left Ratchet Pawl Arm                         |
| -   | <b>03573-95</b> | 1 | Right Ratchet Pawl Arm                        |
| 12. | <b>03574-95</b> | 1 | Ratchet Handle                                |
| 13. | <b>03575-95</b> | 1 | Left Outer Ratchet Gear                       |
| -   | <b>03576-95</b> | 1 | Right Outer Ratchet Gear                      |
| 14. | <b>03666</b>    | 1 | 5/16" x 1-1/4" Roll Pin                       |
| 15. | <b>03668</b>    | 1 | 1" x 18 Gauge Machine Washer                  |
| 16. | <b>03578</b>    | 1 | 5/16"-18 UNC x 1/2" Socket Head Shoulder Bolt |
| 17. | <b>01998</b>    | 1 | 5/16" Flat Washer (Stainless Steel)           |
| 18. | <b>02002</b>    | 1 | 1/4" Flat Washer (Stainless Steel)            |

# TILT-BED LATCH ASSEMBLY

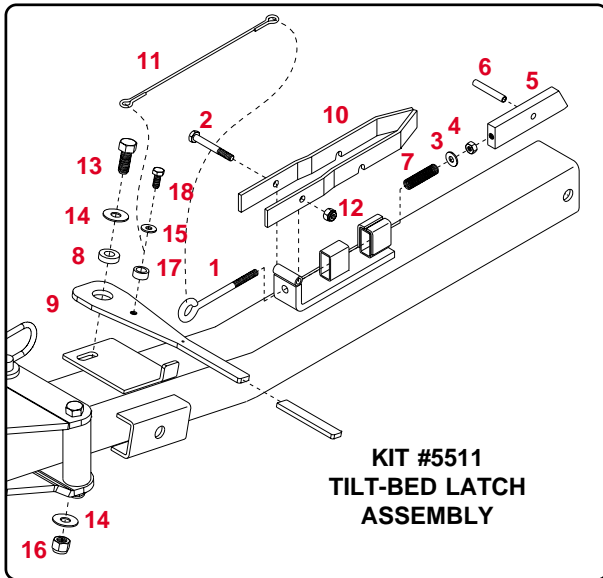

| REF. NO. | PART NO.        | QTY. | DESCRIPTION                                  |
|----------|-----------------|------|--|
|          | <b>5511</b>     | -    | <b>Tilt-Bed Latch Kit</b>                    |
| 1*       | <b>03434</b>    | 1    | 5/16"-18 UNC x 4" Eye Bolt                   |
| 2*       | <b>04221</b>    | 1    | 5/16"-18 UNC x 2-1/2 Hex Head Bolt (Gr 5)    |
| 3*       | <b>00004</b>    | 1    | 5/16" Flatwasher                             |
| 4*       | <b>00007</b>    | 1    | 5/16"-18 UNC Hex Nut                         |
| 5*       | <b>03379-95</b> | 1    | Latch Block                                  |
| 6*       | <b>03435</b>    | 1    | Roll Pin (5/16" x 2-1/4")                    |
| 7*       | <b>03499</b>    | 1    | Latch Spring - Stainless Steel               |
| 8.       | <b>03382-95</b> | 1    | Latch Handle Pivot Bushing                   |
| 9.       | <b>03574-95</b> | 1    | Latch Handle                                 |
| 10.      | <b>03381-95</b> | 1    | Latch Catch                                  |
| 11.      | <b>03433</b>    | 1    | Latch Cable                                  |
| 12.      | <b>02802</b>    | 1    | 5/16"-18 UNC Nylon Insert Locknut            |
| 13.      | <b>00967</b>    | 1    | 1/2"-13UNC x 1-1/4" lg. Hex Head Bolt (gr.5) |
| 14.      | <b>00085</b>    | 2    | 1/2" Flatwasher                              |
| 15.      | <b>00059</b>    | 1    | 3/8" Flat Washer                             |
| 16.      | <b>02178</b>    | 1    | 1/2"-13UNC Nylon Insert Locknut              |
| 17.      | <b>05449</b>    | 1    | Spacer Bushing - Stainless Steel             |
| 18.      | <b>05444</b>    | 1    | 3/8"-16 UNC x 3/4" Epoxied Hex Bolt (Gr 5)   |

Please order replacement parts by **PART NO.** and **DESCRIPTION.**

\* Items included in 5511 kit

## RAMP LATCH ASSEMBLY

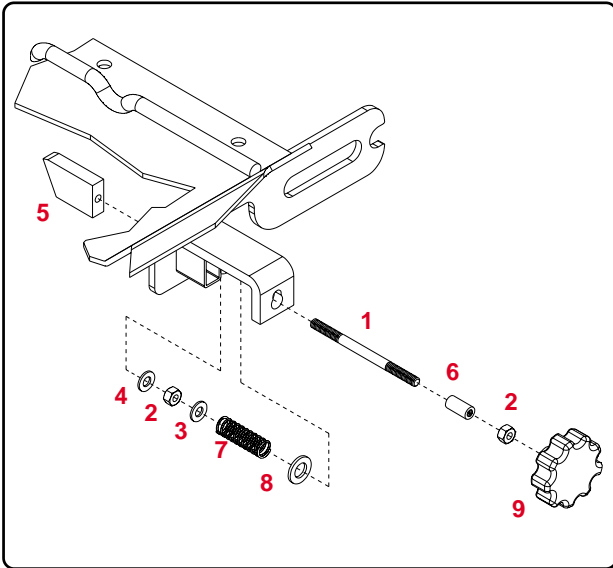

| REF. NO. | PART NO.        | QTY. | DESCRIPTION                    |
|----------|-----------------|------|--------------------------------|
|          | <b>5763</b>     | -    | <b>Ramp Latch Kit</b>          |
| 1.       | <b>11622-95</b> | 1    | 5/16"-18 UNC Latch Rod         |
| 2.       | <b>00007</b>    | 2    | 5/16"-18 UNC Hex Nut           |
| 3.       | <b>00004</b>    | 1    | 5/16" Flatwasher               |
| 4.       | <b>00059</b>    | 1    | 3/8" Flatwasher                |
| 5.       | <b>11570-95</b> | 1    | Latch Block                    |
| 6.       | <b>11623-95</b> | 1    | Threaded Bushing               |
| 7.       | <b>03499</b>    | 1    | Latch Spring - Stainless Steel |
| 8.       | <b>02384</b>    | 1    | 1/2" Narrow Machine Washer     |
| 9.       | <b>11621</b>    | 1    | Handle/Knob                    |

Please order replacement parts by **PART NO.** and **DESCRIPTION.**

## LICENSE PLATE BRACKET ASSEMBLY

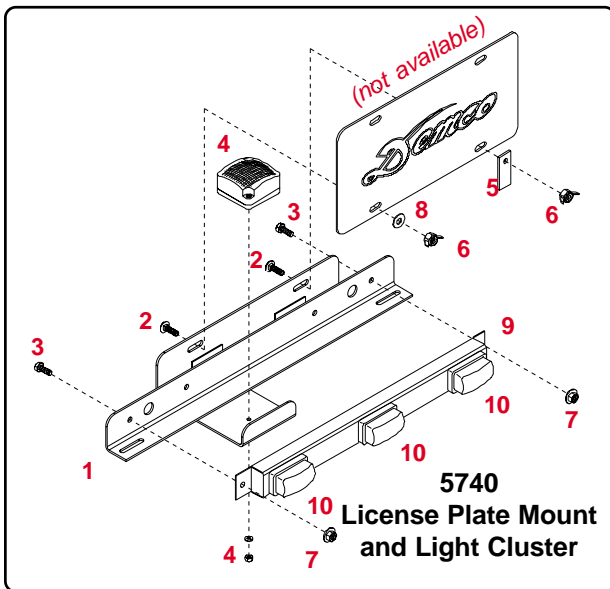

| REF. NO. | PART NO.        | QTY. | DESCRIPTION                                     |
|----------|-----------------|------|---|
|          | <b>5740</b>     | -    | <b>License Plate Bracket and Light Assembly</b> |
| 1.       | <b>04505-95</b> | 1    | License Plate and Light Cluster Bracket         |
| 2.       | <b>04176</b>    | 2    | 1/4"-20UNC X 3/4" Carriage Bolt                 |
| 3.       | <b>02214</b>    | 2    | #10 NC X 1/2" Slotted Truss Head Screw          |
| 4.       | <b>02163</b>    | 1    | Square License Plate Light w/Washer and Nut     |
| -        | <b>02164</b>    | -    | Clear License Plate Light Lens Only             |
| 5.       | <b>02580-95</b> | 1    | License Plate Clip                              |
| 6.       | <b>02770</b>    | 2    | 1/4"-20UNC Nylon Insert Wing Nut                |
| 7.       | <b>02205</b>    | 2    | #10 NC Nylon Lock Nut                           |
| 8.       | <b>00214</b>    | 1    | 1/4"-20UNC Flat Washer                          |
| 9.       | <b>11687*</b>   | 1    | 3 Cluster Light Bar Only (No Lights)            |
| 10.      | <b>11688*</b>   | 3    | Red LED Light                                   |
| -        | <b>11655*</b>   | 1    | 3 Cluster LED Wiring Harness                    |
| -        | <b>11616</b>    | 1    | Grommet, 5/8" OD x 3/8" x 1/8" Thick            |
| -        | <b>5765</b>     | -    | 3 Cluster LED Light Assembly (* Included)       |

Please order replacement parts by **PART NO.** and **DESCRIPTION.**

# Fender Assembly

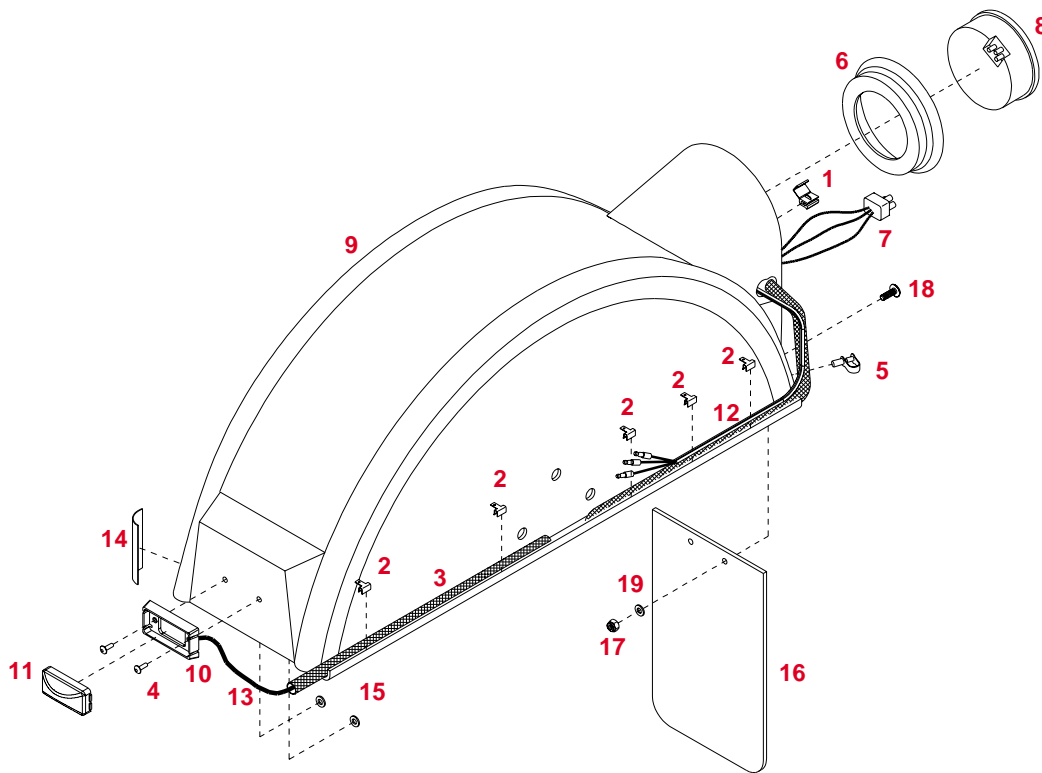

## PARTS LIST

| REF. NO. | PART NO.     | QTY. | DESCRIPTION                  |
|----------|--------------|------|------------------------------|
|          | <b>5736</b>  | -    | <b>Left Fender Assembly</b>  |
|          | <b>5737</b>  | -    | <b>Right Fender Assembly</b> |
| 1.       | <b>01883</b> | 2    | Wire Splicer                 |
| 2.       | <b>04425</b> | 5    | Tinnerman U-clamp            |
| 3.       | <b>04515</b> | 1    | 17-1/2" Wire Loom            |
| 4.       | <b>04643</b> | 2    | 9/16" x 5/8" Pop Rivet       |
| 5.       | <b>05443</b> | 1    | Nylon Cable Hanger           |
| 6.       | <b>05447</b> | 1    | 4" Light Grommet             |
| 7.       | <b>11206</b> | 1    | Tail Light Wire Harness      |
| 8.       | <b>11209</b> | 1    | 4" LED Tail Light            |
| 9.       | <b>11595</b> | 1    | Left Fender Assembly         |
| -        | <b>11596</b> | 1    | Right Fender Assembly        |
| 10.      | <b>11604</b> | 1    | Chrome LED Marker Base Mount |
| 11.      | <b>11605</b> | 1    | Yellow LED Marker Light      |
| 12.      | <b>11619</b> | 1    | 12" Wire Loom                |
| 13.      | <b>11654</b> | 1    | Front Marker Wiring Harness  |
| 14.      | <b>04508</b> | 1    | Amber Reflector              |
| -        | <b>04804</b> | 1    | Red Reflector                |
| 15.      | <b>07490</b> | 2    | 3/16" Washer                 |
| 16.      | <b>01769</b> | 1    | Kar Kaddy Mud Flap           |
| 17.      | <b>02772</b> | 2    | 1/4" Nylon Lock Nut          |
| 18.      | <b>05338</b> | 2    | 1/4" Slotted Truss Head Bolt |
| 19.      | <b>00214</b> | 2    | 1/4" Flat Washer             |

Please order replacement parts by PART NO. and DESCRIPTION.

## OPTIONAL SPARE TIRE and MOUNT PARTS BREAKDOWN

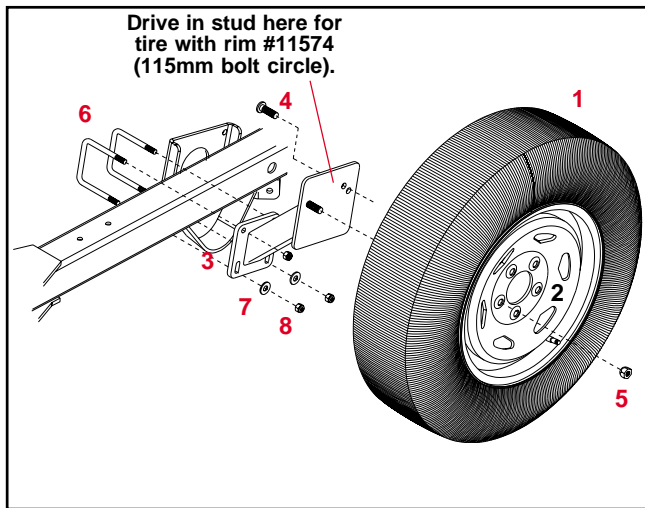

### PARTS LIST

|  |                 |   |                                       |
|--|-----------------|---|---------------------------------------|
| -  | <b>5734</b>     | 1 | <b>Optional Spare Tire and Rim</b>    |
| 1.   | <b>N/A</b>      | 1 | ST205/75R 14"x"C" ROWL RadialTire     |
| 2.   | <b>11574</b>    | 1 | 6" x 14" Chrome Rim 115mm Bolt Circle |
| <b>RKSTM 1 Spare Tire Mounting Bracket</b> |                 |   |                                       |
| 3.   | <b>02193-30</b> | 1 | Spare Tire Bracket                    |
| 4.   | <b>02917</b>    | 1 | Stud Bolt (12mm x 1.5)                |
| 5.   | <b>02933</b>    | 2 | Wheel Nut (12mm) Chrome               |
| 6.   | <b>02759</b>    | 2 | 3/8"-16UNC Square U-Bolt              |
| 7.   | <b>00059</b>    | 2 | 3/8" Flatwasher                       |
| 8.   | <b>02592</b>    | 4 | 3/8"-16UNC Nylon Insert Locknut       |
| -  | <b>KK6TC</b>    |   | Optional Spare Tire Cover             |

Please order replacement parts by **PART NO. & DESCRIPTION.**

\* All options may not mount on tow dolly simultaneously.\*

## OPTIONAL TOOL BOX

### PARTS LIST

|    |                 |   |                                      |
|----|-----------------|---|--------------------------------------|
|    | <b>RKTB</b>     | 1 | <b>Optional Tool Box</b>             |
| 1. | <b>00059</b>    | 4 | 3/8" Flatwasher                      |
| 2. | <b>02592</b>    | 8 | 3/8"-16UNC Nylon Insert Locknut      |
| 3. | <b>01888-30</b> | 1 | Tool Box                             |
| 4. | <b>00182</b>    | 1 | Small Hair Pin                       |
| 5. | <b>02742-30</b> | 2 | Mounting "Z" Bracket                 |
| 6. | <b>00907</b>    | 4 | 3/8"-16UNC x 1" Hex Head Bolt (gr.5) |
| 7. | <b>02759</b>    | 2 | 3/8"-16UNC x 3" Square U-Bolt        |

Please order replacement parts by **PART NO. and DESCRIPTION.**

\* All options may not mount on tow dolly simultaneously.\*

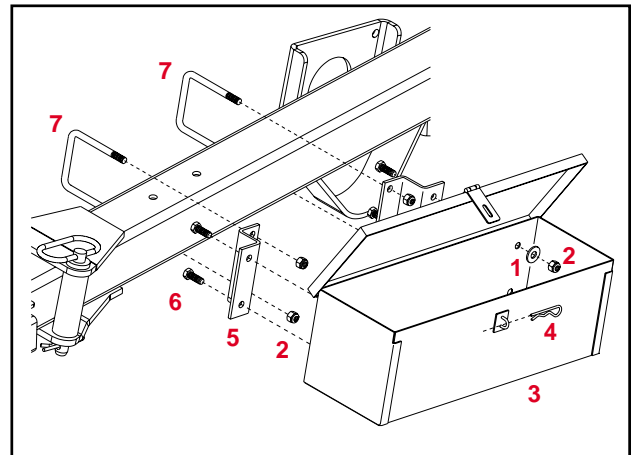

# OPTIONAL LIGHT BAR PARTS BREAKDOWN

## LIGHT BAR PARTS LIST

| REF. NO.                                   | PART NO. | QTY. | DESCRIPTION                                 |
|--|----------|------|---|
| <b>RKLB Kar Kaddy Light Bar (complete)</b> |          |      |   |
| 1.   | 01772    | 2    | Nylon Security Strap with hooks & tightener |
| 2.   | 01857    | 1    | Left Tail/ Brake and Signal Light w/Lenses  |
| 3.   | 01773    | 1    | Brown Jumper Wire                           |
| 4.   | 01886    | 4    | Wire Holder (metal)                         |
| 5.   | 02385-50 | 1    | Light Bar Framework                         |
| 6.   | 02386-50 | 2    | Adjustable Light Bracket                    |
| 7.   | 01856    | 1    | Right Tail/ Brake and Signal Light w/Lenses |
| 8.   | 02772    | 10   | 1/4"-20UNC Nylon Insert Locknut             |
| 9.   | 00092    | 6    | 1/4"-20UNC x 1/2" Hex Head Bolt             |
| 10.  | 01777-50 | 2    | Light Bar "Z" Bracket                       |
| 11.  | 01778    | 4    | 3" Suction Cup w/Bolt (#13)                 |
| 12.  | 02198    | 1    | Light Bar Wiring Harness (new style)        |
| 13.  | 00068    | 4    | 1/4"-20UNC x 3/4" Hex Head Bolt             |
| 14.  | 01911    | -    | Large Red Lens                              |
| 15.  | 01912    | -    | Small Red Lens                              |
| 16.  | 01890    | -    | Clear Lens                                  |

Please order replacement parts by PART NO. and DESCRIPTION.

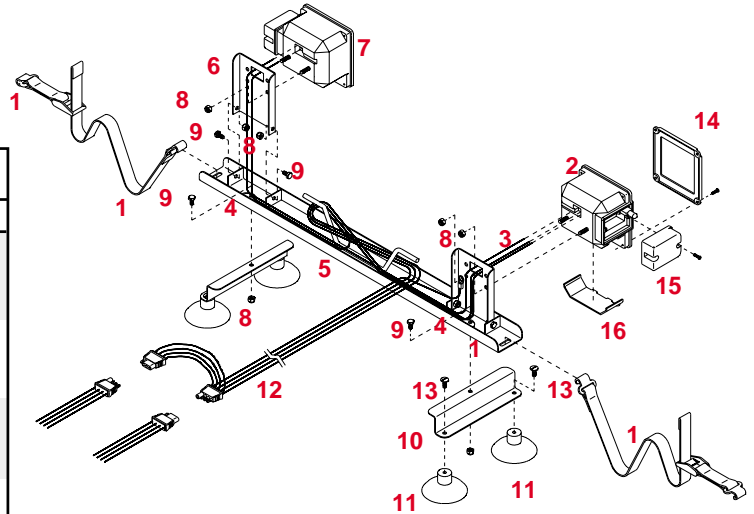

### COLOR CODE FOR WIRING HARNESS

|               |   |
|---------------|---|
| <b>WHITE</b>  | Ground  |
| <b>BROWN</b>  | Tail Lights, License Plate Lights, Light Cluster Bar & Clearance Lights |
| <b>YELLOW</b> | Left Turn and Stop  |
| <b>GREEN</b>  | Right Turn and Stop   |

## OPTIONAL DEFLECTOR

### OPTIONAL DEFLECTOR PARTS LIST

| REF. NO.                       | PART NO. | QTY. | DESCRIPTION                                    |
|--------------------------------|----------|------|--|
| <b>5762 Optional Deflector</b> |          |      |  |
| 1.                             | 02055-30 | 2    | Deflector Framework                            |
| 2.                             | 02592    | 4    | 3/8"-16UNC Nylon Insert Lock Nut               |
| 3.                             | 02759    | 2    | 3/8"-16UNC Square U-Bolt (fits around 3" tube) |
| 4.                             | 00161-95 | 2    | Lock Handle                                    |
| 5.                             | 02054-30 | 1    | Deflector Slide Mount                          |
| 6.                             | 00095    | 4    | 3/8"-16UNC x 3/4" lg. Square Head Set Screw    |
| 7.                             | 02743-30 | 1    | Deflector Upright Post                         |
| 8.                             | 02165    | 1    | Deflector Lacing Cord (1/8" x 25 ft.)          |
| 9.                             | 11710    | 1    | Deflector Fabric                               |

Please order replacement parts by PART NO. and DESCRIPTION.

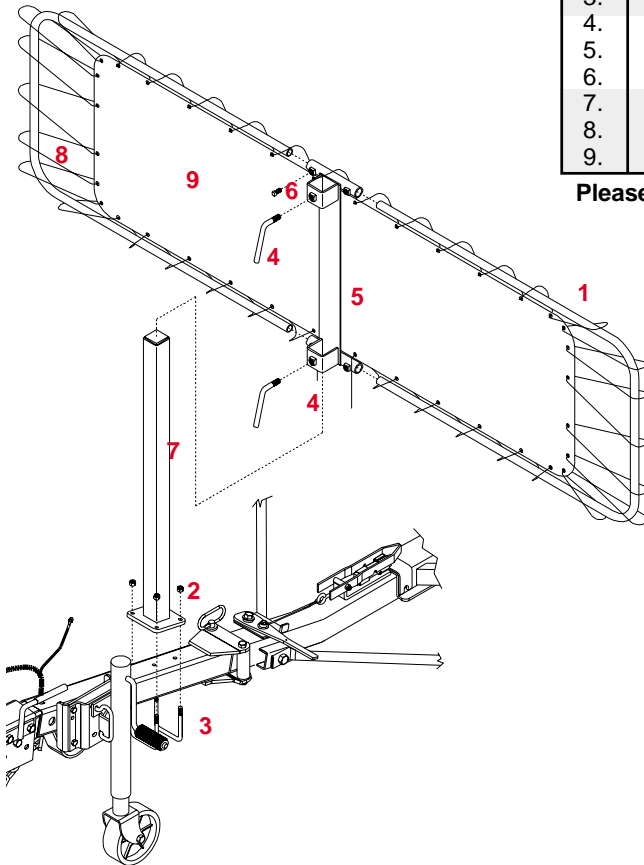

# DEMCO PRODUCTS - KAR KADDY ORIGINAL PURCHASER'S LIMITED WARRANTY

## 1. Extent and Duration of this Warranty:

Your Demco Kar Kaddy is warranted to be free from defects in materials and workmanship under normal use and service for a period of one year after date of purchase by the original (first) retail owner, or until it is resold or transferred by the original owner. Hubs used on the Kar Kaddy are warranted for a period of three years after the date of purchase by the original (first) retail owner or until it's resold or transferred by the original owner. Tires and lights are not included in this warranty.

Tires are warranted by the manufacturer against defects in materials and workmanship, but not against road hazards.

Any part of the Demco Kar Kaddy, except tires and lights, found, in the judgement of the manufacturer to be defective in materials or workmanship will be repaired or replaced at the manufacturer's option without charge for parts or labor to the original owner.

## 2. Manufacturer and Warrantor of Tow Dolly:

Dethmers Manufacturing Co.  
4010 320th Street  
P.O. Box 189  
Boyden, IA 51234  
(712) 725-2311

The manufacturer and warrantor of the tires has his name permanently molded into the tires. Tire warranty questions and claims can be taken directly to an authorized dealer of the tire manufacturer.

## 3. Repair or Replacement Procedure:

If your Demco Kar Kaddy develops a defect (except for tires or lights) during the warranty period, promptly notify Dethmers Manufacturing Co. customer service department. Until such notice is received, Warrantor will not be responsible for any repair or replacement.

Upon receipt of notice from you, Warrantor will have a choice of options in replacing any part it determines to be defective:

- a) Warrantor may require you at your own expense to deliver or ship the part to its factory or authorized dealer. Any defective part will be repaired or replaced and returned to you free of charge. Any part returned to Warrantor and found not to be defective will be returned to you freight collect with an explanation.
- b) Warrantor may elect to ship a new part to its dealer to be exchanged free of charge for the defective part returned by you to the dealer.
- c) Warrantor may elect to ship or deliver a replacement part to your address.

Warranty claims on tires should be presented to a local authorized dealer of the tire manufacturer. Provide proof of purchase when making a tire warranty claim.

## 4. Limitations on Warranty Coverage:

Coverage under this warranty will be effective only when a copy of the original invoice, showing the date and location of purchase, accompanies any claim for warranty.

Warrantor has no liability whatsoever and this warranty is null and void if any Demco Kar Kaddy has been misassembled or subjected

to neglect, negligence, misuse, accident or operated in any way contrary to the operating and maintenance instructions as specified in the Demco Owner's Manual for that model tow dolly.

This warranty does not cover any tow dolly that has been altered or modified so as to affect the tow dolly's operation, performance or durability, or that has been modified to change the intended use of the tow dolly.

In addition, the warranty does not extend to repairs made necessary by normal use of parts, accessories or other equipment which in the judgment of Warrantor, are either incompatible with the Demco Kar Kaddy, or affect its operation, performance or durability.

This warranty does not cover:

- 1) normal wear and tear
- 2) road film or gravel damage to paint or galvanizing
- 3) paint or galvanizing
- 4) rust damage
- 5) Any Demco Kar Kaddy that has been loaded in excess of the load capacity stated on the tow dolly identification label.

Warrantor has a policy of continuous product improvement. We reserve the right to change or improve the design of any Demco Kar Kaddy model, including but not limited to state of the art changes, without assuming any obligation to modify any tow dolly previously manufactured.

Warrantor assumes no responsibility to the owner for loss of use of the tow dolly, loss of time, inconvenience or other damage consequential or otherwise, including, but not limited to expense for gasoline, expense of transporting the tow dolly to the dealer and expense of returning the tow dolly, mechanic's travel time, telephone or telegram charges, road service/towing charges, rental of another tow dolly during the time warranty repairs are being performed, travel, lodging, loss or damage to personal property or loss of revenue or earnings.

## 5. Limitations of Implied Warranties:

All implied warranties, if any, expire and terminate upon expiration of this warranty. Some states do not allow limitation on how long an implied warranty lasts, so this limitation may not apply to you.

## 6. Limitation of Consequential Damages:

Warrantor's responsibility under this warranty extends solely to repair or replacement of your Demco Kar Kaddy and its component parts.

Warrantor does not assume responsibility for, nor shall it be liable for, any special, incidental or consequential damages. Some states do not allow the exclusion or limitation on incidental or consequential damages, so the above exclusion or limitation may not apply to you.

## 7. Use of Vehicle Identification Number (VIN):

The VIN is a 17 digit number located in the lower left corner of the tow dolly identification label. The label is located on the left side of the tow dolly frame. Be sure to include the VIN number in all communications with Warrantor or its dealers concerning the warranty.

## 8. Purchaser's Rights:

This warranty gives you specific legal rights, and you may also have other rights which vary from state to state.

**NOTES:**





# Warranty Registration

Dethmers Manufacturing Company  
4010 320th Street • Box 189 • Boyden, Iowa 51234  
Toll Free 800-54DEMCO (800-543-3626) • FAX 800-845-6420  
www.demco-products.com

- Ag
- RV
- Rental
- Brakes
- Marine

|  | Very Satisfied        | Satisfied             | Dissatisfied          | Very Dissatisfied     |
|--|-----------------------|-----------------------|-----------------------|-----------------------|
| How satisfied are you with our product?  | <input type="radio"/> | <input type="radio"/> | <input type="radio"/> | <input type="radio"/> |
| How satisfied are you with the dealership/distributor sales staff?               | <input type="radio"/> | <input type="radio"/> | <input type="radio"/> | <input type="radio"/> |
| Dealer/Distributor Name _____ City _____ State _____                             |                       |                       |                       |                       |
| How satisfied are you with the company sales staff?                              | <input type="radio"/> | <input type="radio"/> | <input type="radio"/> | <input type="radio"/> |
| How satisfied are you with the delivery?   | <input type="radio"/> | <input type="radio"/> | <input type="radio"/> | <input type="radio"/> |
| Did you have any contact with a Demco Representative?                            | YES                   | NO                    |                       |                       |
| If <b>YES</b> , how satisfied were you?  | <input type="radio"/> | <input type="radio"/> | <input type="radio"/> | <input type="radio"/> |
| I would recommend this product to my family and friends.                         | YES                   | NO                    |                       |                       |
| Would you purchase again from DEMCO?   | YES                   | NO                    |                       |                       |
| Since taking delivery, have you been contacted by the dealer?                    | YES                   | NO                    |                       |                       |
| Did you have any problems with this DEMCO product?                               | YES                   | NO                    |                       |                       |
| If <b>YES</b> , are you satisfied with the company's resolution of your problem? | <input type="radio"/> | <input type="radio"/> | <input type="radio"/> | <input type="radio"/> |

Why did you purchase this product? \_\_\_\_\_

Please list the specific source of information prompting this purchase.  
\_\_\_\_\_

After purchasing this product, do you see any needed product improvement? \_\_\_\_\_ If yes, what improvement? \_\_\_\_\_

What other products would you like to see DEMCO offer? \_\_\_\_\_

Comments \_\_\_\_\_

Owner's Name: \_\_\_\_\_ Mailing Address: \_\_\_\_\_

City: \_\_\_\_\_ State: \_\_\_\_\_ Zip Code: \_\_\_\_\_

Model#: \_\_\_\_\_

Serial #: \_\_\_\_\_

Purchase Date: \_\_\_\_\_

Owner's Signature: \_\_\_\_\_

Please return to DETHMERS MFG. CO. By FAX or tri-folding this form to the backside, it is pre-addressed.

Postage

*Dethmers Manufacturing Company  
4010 320th Street, Box 189  
Boyden, Iowa 51234*

**NOTES:**



**DETHMERS MFG. COMPANY**

**P.O. BOX 189**

**4010 320th St., BOYDEN, IA. 51234**

**PH: (712) 725-2311 FAX: (800) 845-6420**

**TOLL FREE: 1-800-54DEMCO (1-800-543-3626)**

**[www.demco-products.com](http://www.demco-products.com)**