

# DAEWOO

## Service Manual

Auto Washer

Model : DWF-750/752/800/802

753/755/803/805

756/758/806/808

### ✓ Caution

: In this Manual, some parts can be changed for improving, their performance without notice in the parts list. So, if you need the latest parts information, please refer to PPL(Parts Price List) in Service Information Center (<http://svc.dwe.co.kr>).



DAEWOO ELECTRONICS CO., LTD.



# 1. SPECIFICATIONS

NO.	ITEM	DWF-750/753/756	DWF-752/755/758	DWF-800/803/806	DWF-802/805/808
1	POWER SOURCE	AVAILABLE IN ALL LOCAL AC VOLTAGE			
2	POWER	50Hz	320W		
	CONSUMPTION	60Hz	300W(110~127V) / 340W(220V)		
3	MACHINE	NET	28kg/28.5kg(pump)	28.5kg/29kg(pump)	
	WEIGHT	GROSS	31.5kg/32kg(pump)	32kg/32.5kg(pump)	
4	DIMENSION (WXHXD)	525X858X535	525X948X535	525X858X535	525X948X535
5	MATERIAL OF INTERNAL TUB	PLASTIC		STAINLESS STEEL	
6	WATER LEVEL SELECTOR	HIGH(55l), MID(45l), LOW(31l)			
7	OPERATING WATER PRESSURE	0.3kgf/cm <sup>2</sup> ~8kgf/cm <sup>2</sup> (2.94 N/cm <sup>2</sup> ~78.4N/cm <sup>2</sup> )			
8	MAXIMUM MASS OF TEXTILE	5.5kg		6.0kg	
9	REVOLUTION PER MINUTE	WASH	125~145(50Hz), 130~150(60Hz)		
		SPIN	710~725(50Hz), 760~785(60Hz)		
		SUIT	50(50Hz), 60(60Hz)		
10	WATER CONSUMPTION	APPROX. 130l/CYCLE			
11	WATER LEVEL CONTROL	ELECTRONICAL SENSOR			
12	ANTI NOISE PLATE	OPTION			
13	GEAR MECHANISM ASS'Y	SPUR GEAR			
14	LINT FILTER	O			
15	SOFTENER INLET	O			
16	ALARM SIGNAL	O			
17	AUTO. WATER SUPPLY	O			
18	FUNCTION FOR BUBBLE	OPTION			
19	AUTO RE-FEED WATER	O			
20	AUTO POWER OFF	O			

## 2. STRUCTURE OF THE WASHING MACHINE

The parts and features of your washer are illustrated on this page.  
Become familiar with all parts and features before using your washer.

### NOTE

- The drawing in this book may vary from your washer model. They are designed to show the different features of all models covered by this book, Your model may not include all features.
- Page references are included next to same features.  
Refer to those pages for more information about the features.

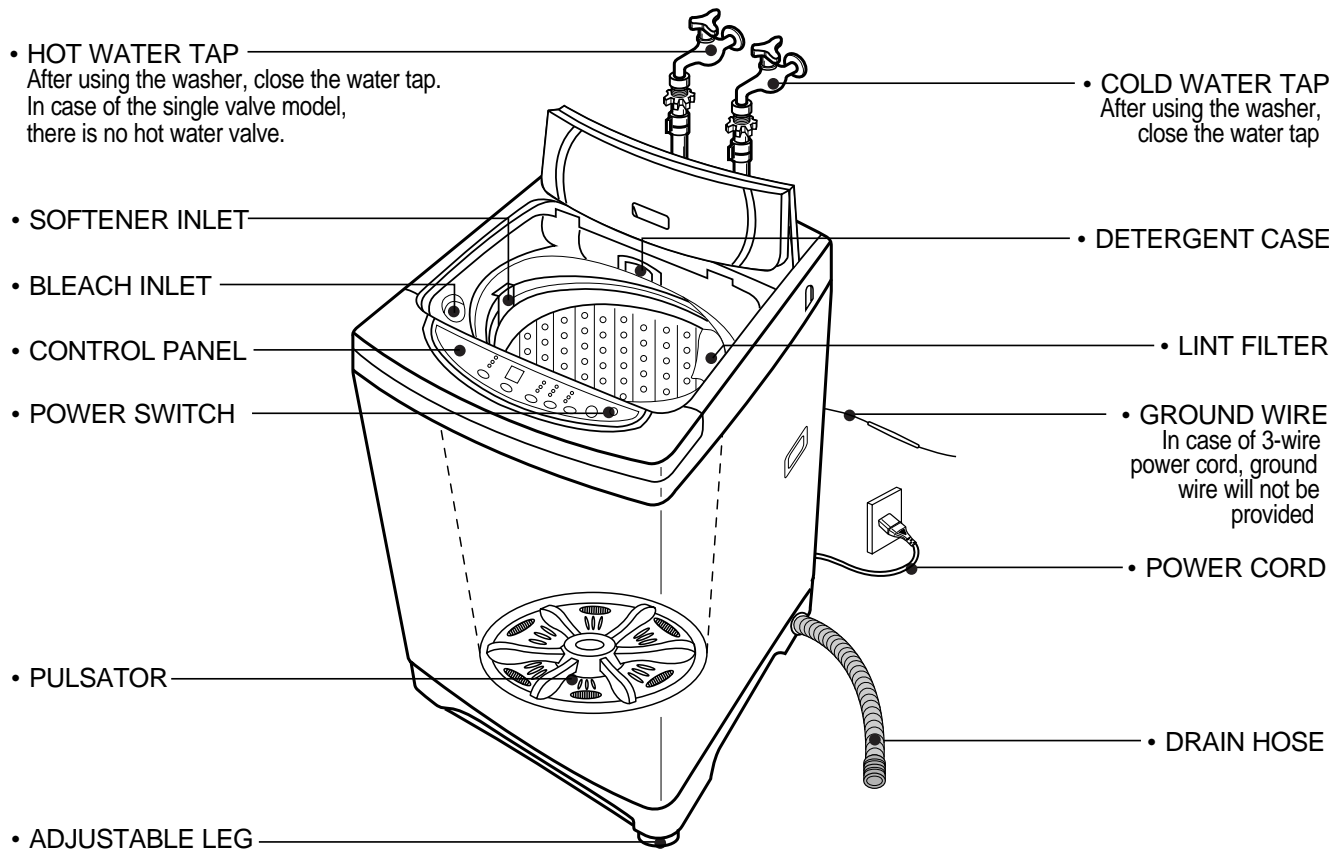

### Accessories

DRYTEN(OPTION)	HOSE ADAPTER	UNDER COVER(OPTION)	HOSE CONNECTOR(OPTION)
	 In case of screw shaped inlet hoses water tap adapters will not be provided.		
DRAIN HOSE		INLET HOSE(OPTION)	CONNECTOR INLET(OPTION)
 NON PUMP MODEL	 PUMP MODEL		

### 3. FUNCTIONS OF THE CONTROL PANEL

Control panel has micom sensor.

As the buttons are pressed, the lamps indicating the selection of your desired washing program will light up.

1. DWF-750/752/800/802

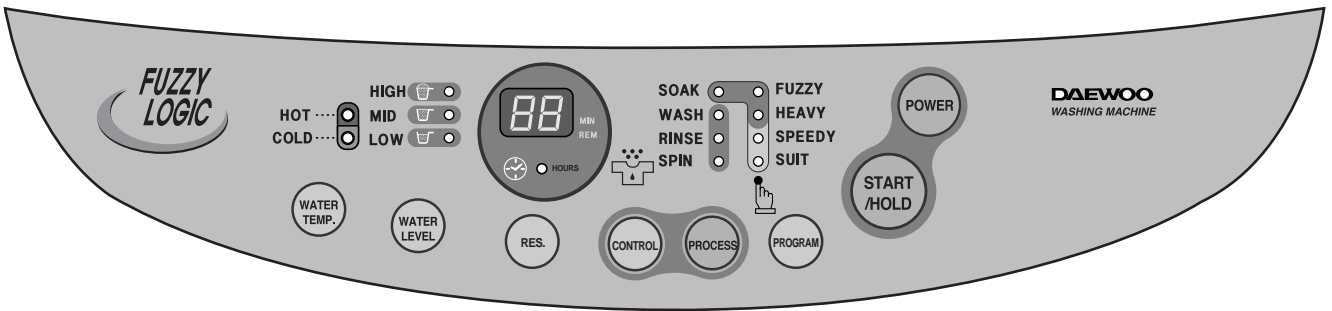











2. DWF-753/755/803/805



POWER	<ul style="list-style-type: none"> <li>• Press this switch to turn the power on or off.</li> </ul>
WATER TEMP.	<ul style="list-style-type: none"> <li>• It can be used to choose water temperature to be supplied.</li> <li>• As the button is pressed, water temperature will be repeated. COLD → COLD+HOT → HOT</li> <li>• In case of the single valve model, there is no wash temperature selector function.</li> </ul>
WATER LEVEL	<ul style="list-style-type: none"> <li>• It can be used to adjust amount of water according to the size of the load to be washed.</li> <li>• As the button is pressed, water level is selected by MID → HIGH → LOW</li> </ul>
RES.	<ul style="list-style-type: none"> <li>• It can be used to pre-engage time for wash.</li> </ul>
PROCESS	<ul style="list-style-type: none"> <li>• It is the button for the partial process or the combination of each process (wash, rinse, spin)</li> </ul>
CONTROL	<ul style="list-style-type: none"> <li>• If you want to change wash time, rinse times, spin time, you must press this button after selecting each process by the process button. Also, this button can be used to spin only.</li> </ul>
PROGRAM	<ul style="list-style-type: none"> <li>• It can be used to select the full-automatic program.</li> <li>• As the button is pressed, program will be selected by following order : FUZZY → FUZZY+SOAK → HEAVY → HEAVY+SOAK → SPEEDY → SUIT(WOOL)</li> </ul>
START /HOLD	<ul style="list-style-type: none"> <li>• Operation and temporary stop is repeated as it is pressed.</li> <li>• When you want to change program in operating; press the "START/HOLD" button → Select the program that you want to change → press the "START/HOLD" button again.</li> </ul>

3. DWF-756/758/806/808



	<ul style="list-style-type: none"> <li>• Press this switch to turn the power on or off.</li> </ul>
	<ul style="list-style-type: none"> <li>• It can be used to choose water temperature to be supplied.</li> <li>• As the button is pressed, water temperature will be repeated. COLD → COLD+HOT → HOT</li> <li>• In case of the single valve model, there is no wash temperature selector function.</li> </ul>
	<ul style="list-style-type: none"> <li>• It can be used to adjust amount of water according to the size of the load to be washed.</li> <li>• As the button is pressed, water level is selected by MID → HIGH → LOW</li> </ul>
	<ul style="list-style-type: none"> <li>• It can be used to cancel the full-automatic program.</li> <li>• When the button is pressed, the display will light down. If you want to wash, rinse or spin, you can press one of the buttons.</li> </ul>
	<ul style="list-style-type: none"> <li>• It can be used to pre-engage time for wash.</li> </ul>
	<ul style="list-style-type: none"> <li>• It can be used to select the full-automatic program.</li> <li>• As the button is pressed, program will be selected by following order : FUZZY → HEAVY → SUIT(WOOL) → BLANKET → SPEEDY</li> </ul>
	<ul style="list-style-type: none"> <li>• It can be used to adjust washing time.</li> <li>• As the button is pressed, it will repeat. 6 MIN → 9 → 12 → 15 → 18 → SOAK</li> </ul>
	<ul style="list-style-type: none"> <li>• It can be used to adjust rinse times.</li> <li>• As the button is pressed, it will repeat. 1 TIME → 2 → 3 → 4 → 5</li> </ul>
	<ul style="list-style-type: none"> <li>• It can be used to adjust spin time.</li> <li>• As the button is pressed, it will repeat. 1MIN → 3 → 5 → 7 → 9</li> </ul>
	<ul style="list-style-type: none"> <li>• Operation and temporary stop is repeated as they are pressed.</li> <li>• When you want to change program in operating; press the “START/HOLD” button → Select the program that you want to change → press the “START/HOLD” button again.</li> </ul>

# 4. DIRECTIONS FOR INSTALLATION AND USE

## § Location Of Washer

Check location where washer will be installed. Make sure you have everything necessary for correct installation. Proper installation is your responsibility.

- Do not place or store your washer below 0°C(32°F) to avoid any damage from freezing.
- Install the washer on the horizontal solid floor.

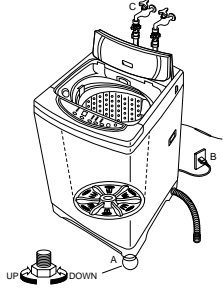
	<p>If the washer is installed on an unsuitable floor, it could make considerable noise, vibrate and cause a malfunction. If washer is not level, adjust the front leg(A) up or down for horizontal setting.</p> <ul style="list-style-type: none"> <li>• Earthed electrical outlet(B) is required with 20cm of bottom back of washer cabinet.</li> <li>• Hot and cold water faucets (C) must be within 1M of the upper back of the washer cabinet and provide water pressure 0.3kgf/cm<sup>2</sup>-8kgf/cm<sup>2</sup>(2.94N/cm<sup>2</sup>-78.4N/cm<sup>2</sup>).</li> </ul>
---	---

## § Drain System

Never forget to install drain hose before operating your washer. The packing box is opened, there are a drain hose.

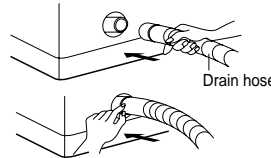
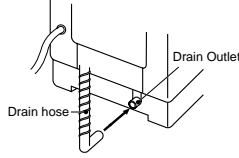
<ul style="list-style-type: none"> <li>• Connect the drain hose to the drain outlet at the back side of the washer.</li> </ul>	
<p><b>Non-Pump Model</b></p>	<p><b>Pump Model</b></p>
	



### NOTES

The opening must not be obstructed by carpeting when the washing machine is installed on a carpeted floor.

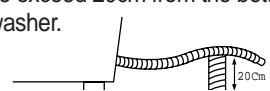
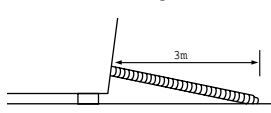
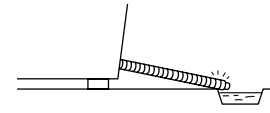
Non-Pump Model		
<p>① In case that it goes over a door sill. Don't let the height of the drain hose exceed 20cm from the bottom of washer.</p> 	<p>② In case of extending the drain hose. Don't let the total length exceed 3m.</p> 	<p>③ Be careful that the end of the drain hose is not immersed in water.</p> 

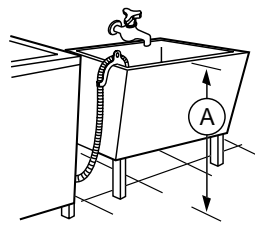
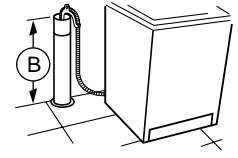
Pump Model	
<p><b>Laundry tub drain system</b></p> <ul style="list-style-type: none"> <li>• Top of tub must be at least 86cm (34inches) high and no higher than 130cm from bottom of washer (A)</li> </ul> 	<p><b>Standpipe drain system</b></p> <ul style="list-style-type: none"> <li>• Needs a 3cm minimum diameter standpipe with minimum carry away capacity of 30liters per minute.</li> <li>• Top of tub must be at least 86cm(34inches) high and no higher than 130cm from bottom of washer (B)</li> </ul> 

## § How to Connect the Inlet Hose

Be careful not to mistake in supplying between the hot(maximum : 50°C) and cold water.

In using only one water tap or in case of attached one water inlet valve, connect the inlet hose to the cold water inlet valve.

Do not over tighten : this could cause damage to couplings.

### •••• FOR ORDINARY TAP

- 1** Pull down the collar of the inlet hose to separate it from the water tap adapter.

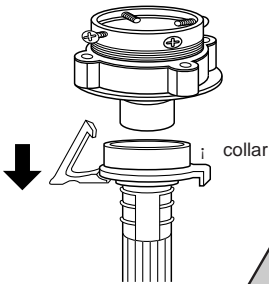

- 2** Loosen the four screws at the water tap adapter, but don't loosen the screws until they are separated from the water tap adapter.

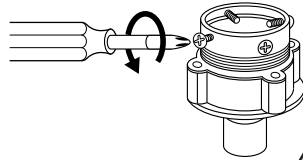

- 3** Connect the water tap adapter to the water tap and tighten the four screws evenly while pushing up the adapter so that the rubber packing can stick to the water tap tightly.

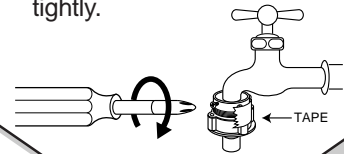

- 4** Remove the tape, and screw connector B into connect A tightly.

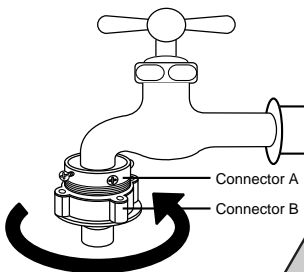

- 5** Connect the inlet hose to the water tap adapter by pulling down the collar of the hose end.

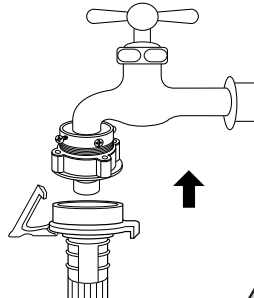

- 6** Connect the inlet hose adapter of the hose to the water inlet of the washer by turning it clockwise to be fixed tightly.

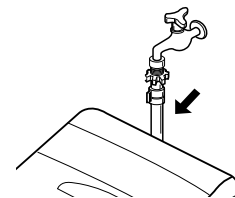

- Please check the rubber packing inside the inlet hose adapter of the hose.

### •••• FOR SCREW-SHAPED TAP

- 1** Connect the inlet hose to the water tap by screwing the connector D tightly.

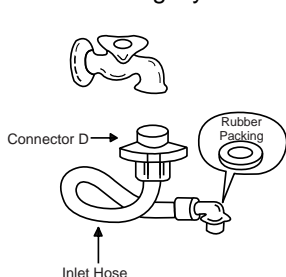

- 2** Connect the connector-inlet supplied if necessary.

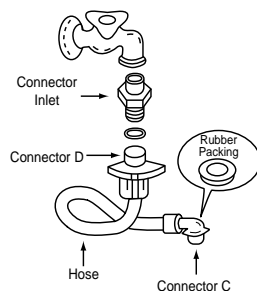

- 3** Insert the inlet hose adapter into the water inlet of washer and turn it to be fixed.



- Assert the packing in the inlet



## § How To Clean The Filter

### •••• CLEANING THE LINT FILTER

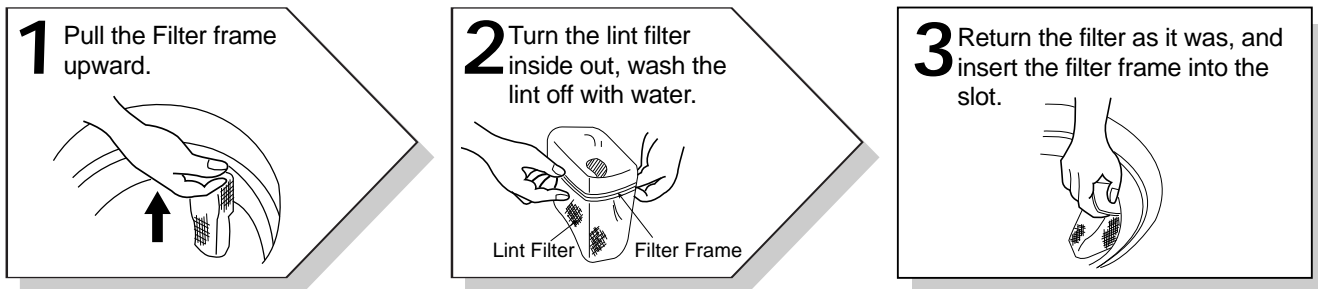

### •••• CLEANING THE WATER INLET FILTER

- Clean the filter when water leaks from the water inlet.

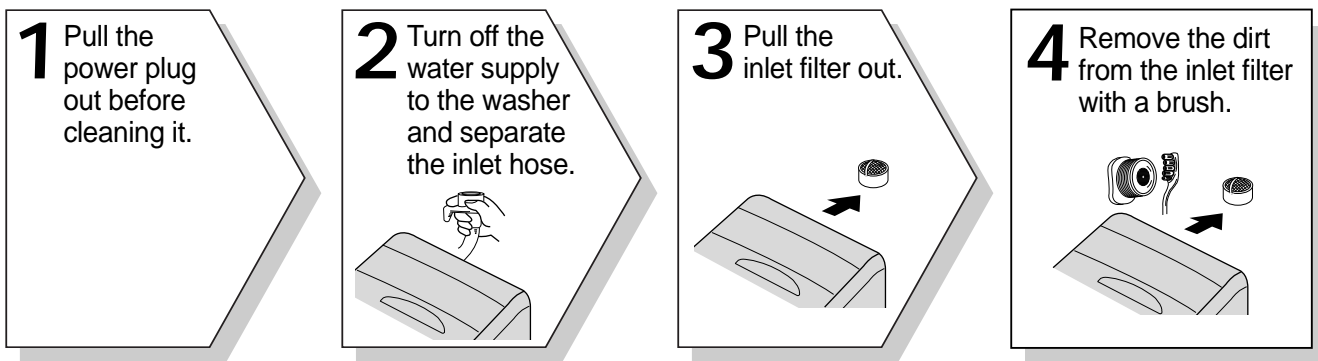

### •••• CLEANING THE DRAIN FILTER

- In case of "U" shaped drain hose, this filter's equipped at the back side of washer.
- This drain filter is to screen the foreign stuffs such as threads, coins, pins, buttons etc ..
- If the drain filter is not cleaned at proper time (every 10 times of use), drain problem could be caused.

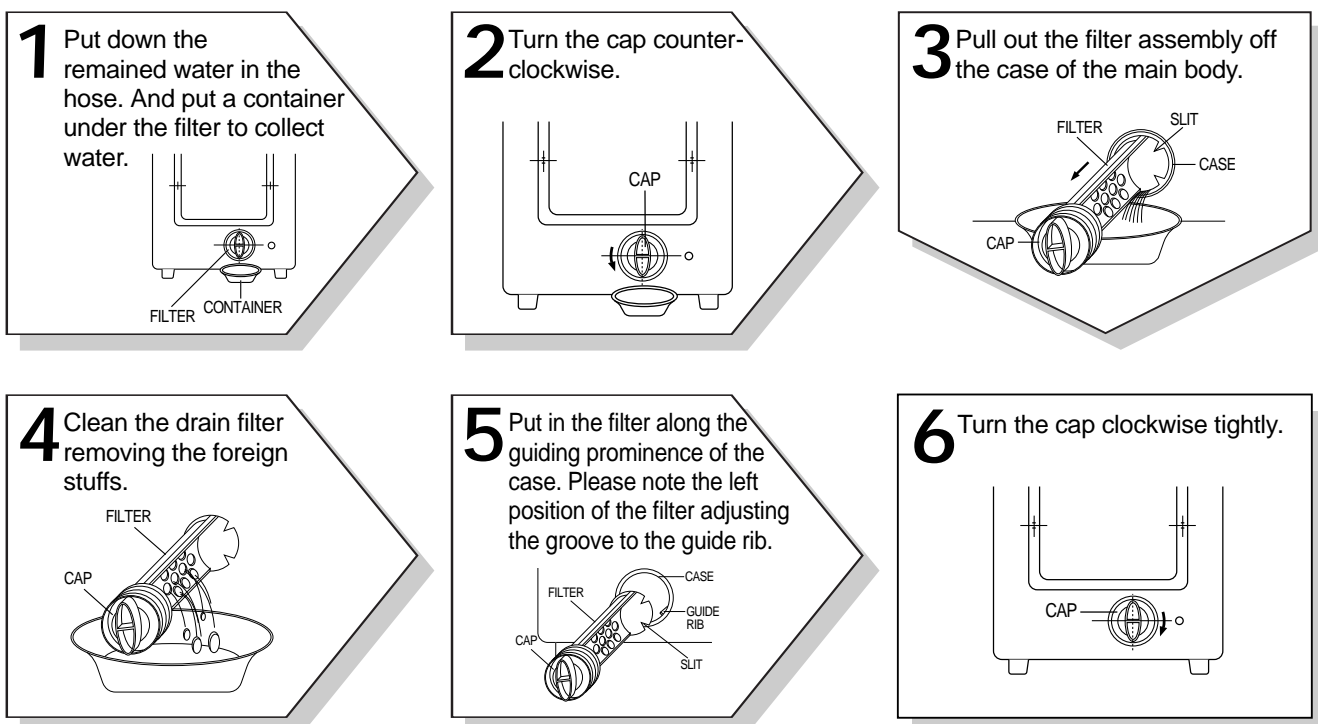

# 5. FEATURE AND TECHNICAL EXPLANATION

## Feature of the Washing Machine

- ① The first air bubble washing system in the world.
- ② Quiet washing through the innovational low-noise design.
- ③ The wash effectiveness is much more enhanced because of the air bubble washing system.
- ④ The laundry detergent dissolves well in water because of the air bubble washing system.
- ⑤ The adoption of the water currents to adjust the unbalanced load.
- ⑥ One-touch operation system.

## Water Current to Adjust the Unbalanced Load

It is a function to prevent eccentricity of the clothes after wash by rotating pulsator C.W and C.C.W for 35 seconds.(But, the SUIT course have no operation of the water currents to adjust the unbalanced load.)

### EFFECT

It reduces vibration and noise effectively while spinning.

### WATER FLOW

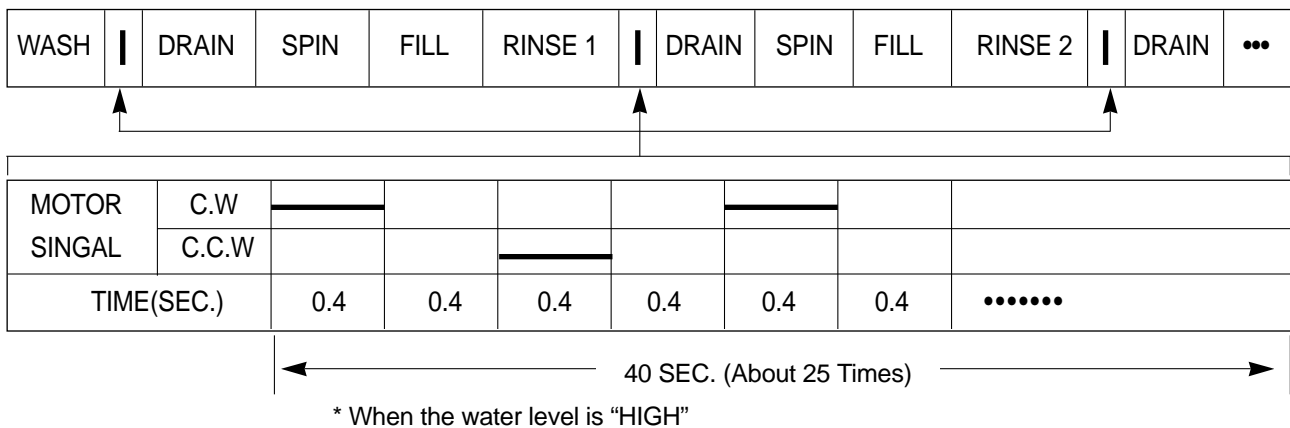

## Automatic Water Supply System

The water level would be lowered because the clothes absorbs water at the beginning of washing. Therefore, after 60 seconds, the operation is interrupted to check the water level, and then the water is supplied again until the selected water level is reached.

## Automatic Draining time Adjustment

This system adjusts the draining time automatically according to the draining condition.

Draining condition	Good draining	The washer begins spin process after drainage.
	Bad draining	Draining time is prolonged.
	No draining	Program is stopped and gives the alarm.

### FUNCTIONAL PRINCIPLE

- ① The micom can remember the time from the beginning of drain to reset point when the pressure switch reaches to "OFF" point

Drain Time	Movement of the Program
Less than 10 minutes	Continue draining
More than 10 minutes	Program stops and gives the alarm with <b>DE</b> blinked on display lamp.

- ② In case of continuous draining, residual drain time is determined by micom.  
Draining time as a whole = D + 40

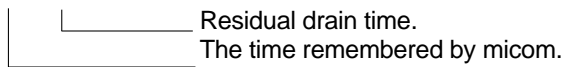

# Softener Dispenser

This is the device to dispense the softener automatically by centrifugal force.  
This is installed inside the auto-balancer.

## FUNCTIONAL PRINCIPLE

- ① Softener stays in room (A) when poured into softener inlet.
- ② Softener moves from (A) to (B) by centrifugal force during intermittent spin process.
- ③ Softener flows from (B) to (C) during rinse process next to intermittent spin.
- ④ Softener moves from (C) to (D) by centrifugal force during second intermittent spin.

After spin process is finished, the softener is added into the tub through softener outlet.

## FLOW OF THE SOFTENER

	Wash	Intermittent Spin	Hold	Intermittent Spin	Rinse	Spin
Normal	Centrifugal force		Flow in	Centrifugal force	Flow in	—
Program	(A)	→ (B)	→ (C)	→ (D)	→	—

## FLOW OF THE SOFTENER INSIDE OF THE BALANCER

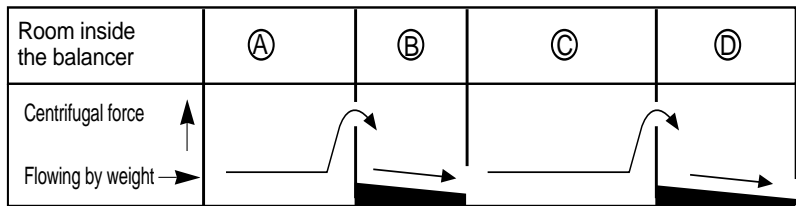

### NOTES

Softener moves into the next room when r.p.m of the tub is more than 100 r.p.m.

## HOW TO CHECK MOVEMENT

Pour a reasonable amount of "MILK" into softener dispenser and operate the washer with no load. In final rinse cycle, make sure that the milk is added into the tub through softener outlet.

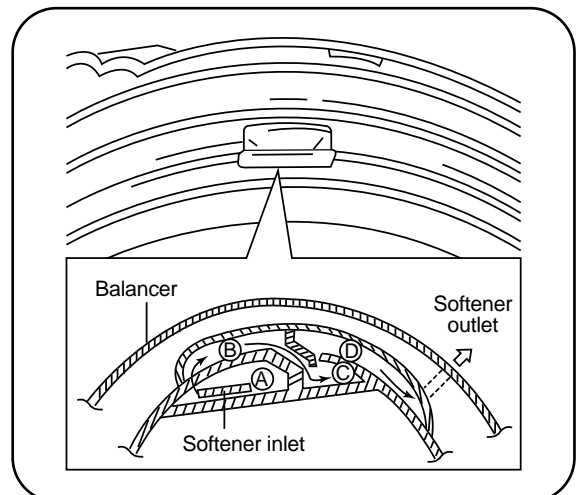

## Automatic Unbalance Adjustment

This system is to prevent abnormal vibration during intermittent spin and spin process.

### FUNCTIONAL PRINCIPLE

- ① When the lid is closed, the safety switch contact is "ON" position.
- ② In case that wash loads get uneven during spin, the outer tub hits the safety switch due to the serious vibration, and the spin process is interrupted.
- ③ In case that P.C.B. ASS'Y gets "OFF" signal from the safety switch, spin process are stopped and rinse process is started automatically by P.C.B. ASS'Y.
- ④ If the safety switch is operated due to the unbalance of the tub, the program is stopped and the alarm is given.



### NOTES

The alarm finished when you close the lid after opening it. Check the unbalance of the wash load and the installation condition.

## Circulating-Water

### CIRCULATING-WATER

The washing and rinsing effects have been improved by adopting the water system in which water in the tub is circulated in a designed pattern.

When the pulsator rotates during the washing or rinsing process, the water below the pulsator vanes creates a water currents as shown in figure.

The water is then discharged from the upper part of the tub through the water channel. About 40 L/min. water is circulated at the 'high' water level, standard wash load and standard water currents.

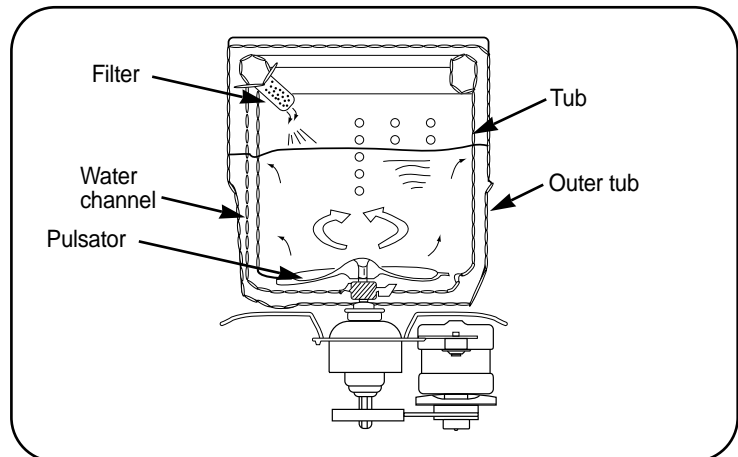

## Lint Filter

Much lint may be obtained according to the kind of clothes to be washed and some of the lint may also sticks to the clothes.

To minimize this possibility a lint filter is provided on the upper part of the tub to filter the wash water as it is discharged from the water channel. It is good to use the lint filter during washing.

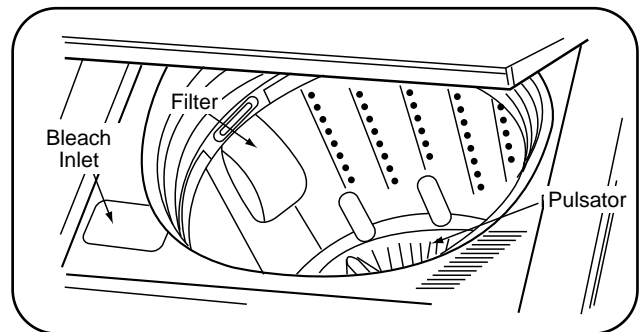

### HOW TO REPLACE LINT FILTER

- ① Pull the filter frame upward.
- ② Turn the lint filter inside out, and wash the lint off with water.
- ③ Return the filter as it was, and fix the filter frame to the slot.

## Residual Time Display

When the START/HOLD button is pressed, the residual time (min.) is displayed on the time indicator, and it will be counted down according to process.

When operation is finished, the TIME INDICATOR will light up .

## Drain Motor

### STRUCTURE

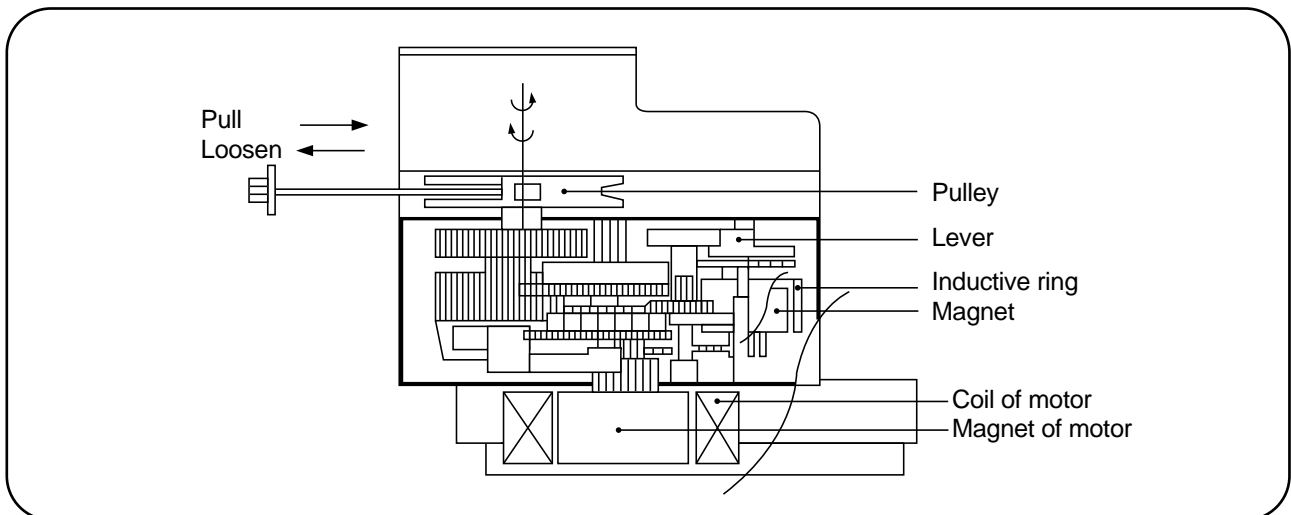

### FUNCTIONAL PRINCIPLE

- ① When the DRAIN MOTOR connected to the power source, the DRAIN MOTOR rotates with 900 r.p.m and revolves the pulley by gear assembly for reducing.
- ② When the pulley is rotated, the pulley winds the wire to open the drain valve.
- ③ Therefore, rotation of pulley changed to the linear moving of wire.
- ④ The wire pulls the brake lever of Gear Mechanism Ass'y within 5 seconds.
- ⑤ After the wire pulled, gear assembly is separated from motor and condition of pulling is held by operation of the lever.
- ⑥ When the power is turned off, the drain valve is closed because the wire returns to original position.

## Gear Mechanism Ass'y

The proper water currents is made by the rotation of pulsator at a low speed to prevent the damage to the small sized clothes.

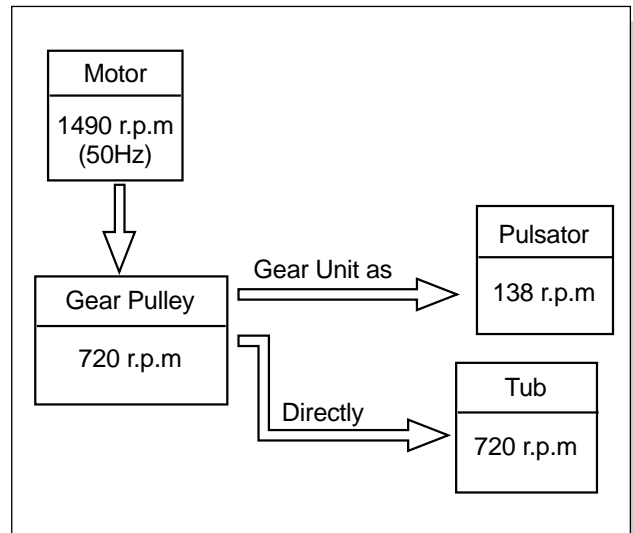
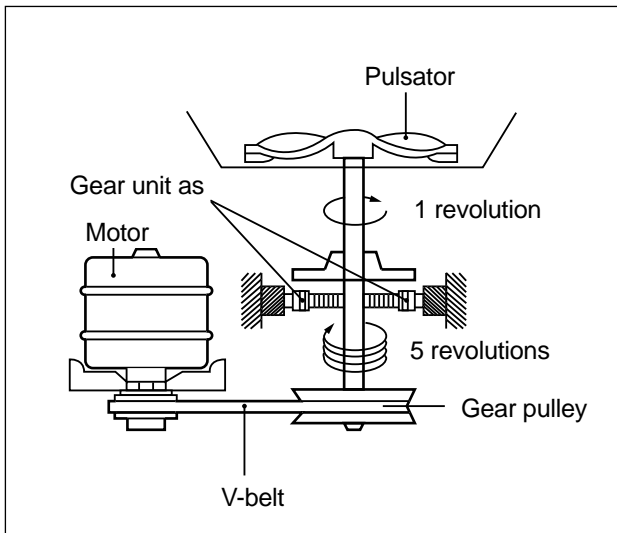
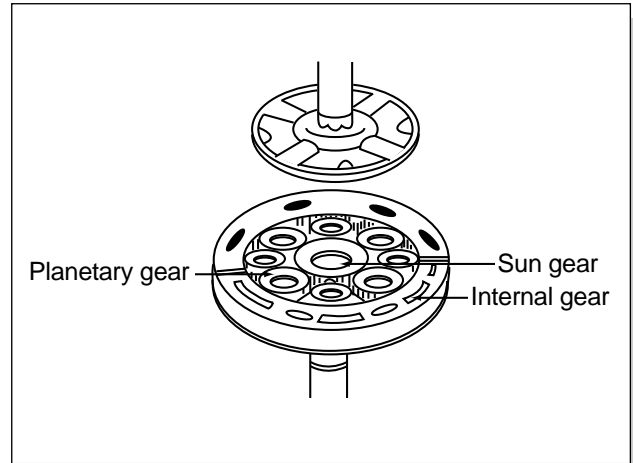
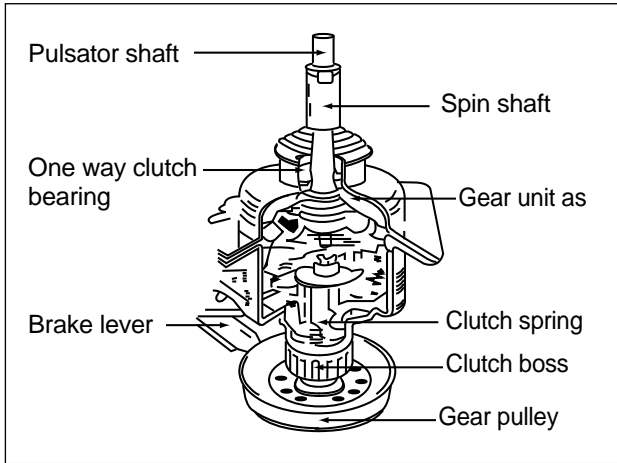

## Principle of Bubble Generator

### STRUCTURE

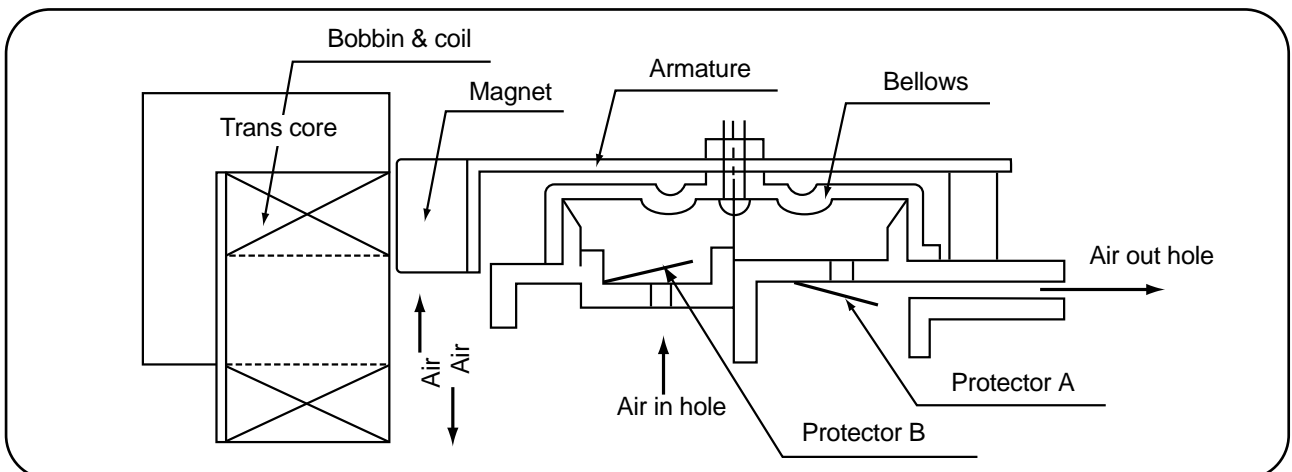

**PRINCIPLE OF INTAKE & OUTLET OF THE AIR**

INTAKE : ARMATURE moves up, and BELLOWS inhales the air. At the same time, protector B is open and A is close.

OUTLET : ARMATURE moves down, and BELLOWS exhales the air. At the same time, protector B is close and A is open.

**FUNCTIONAL PRINCIPLE OF TRANS & MAGNET**

- i The phase of A.C electric power changes to 60 cycle/second.
- i The magnetic pole of trans core is changed by the change of the phase of A.C electric power.
- i The core repeats push and pull (3600 times/min.) of the armature magnet.

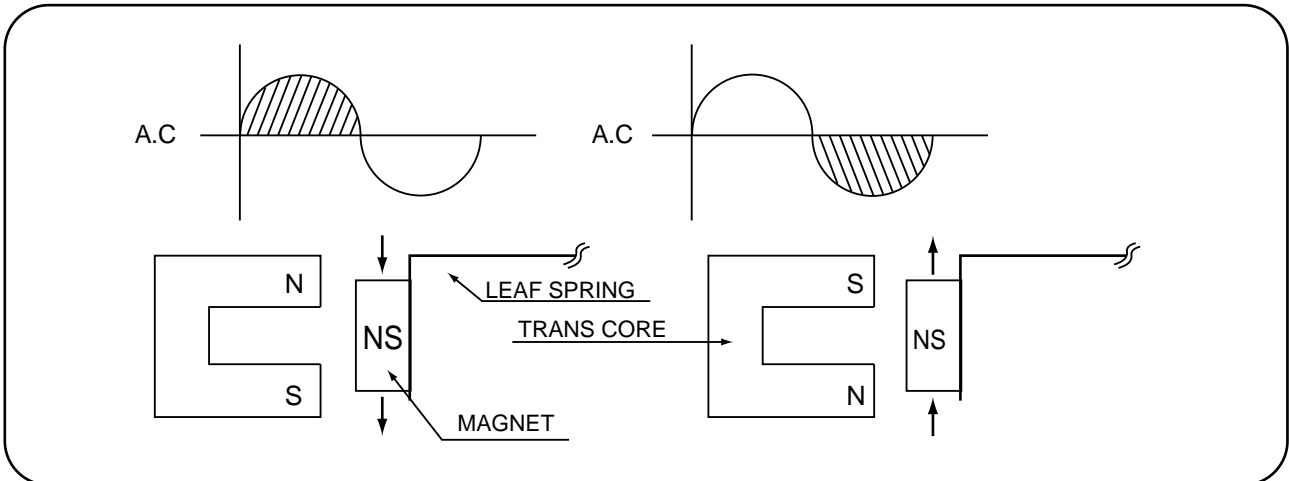

**Functional Principle of Bubble Washing Machine**

**ACROSS SECTION**

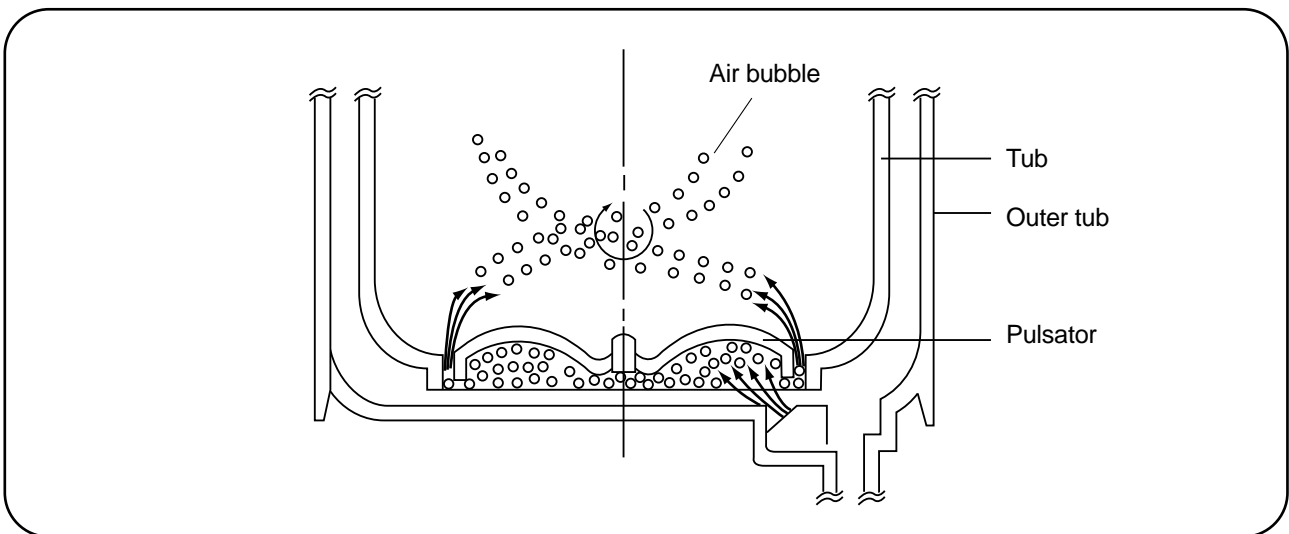

**FUNCTIONAL PRINCIPLE**

Bubble generator supplies the air from the bottom of outer tub to the inner space of pulsator, the air is dispersed by the rotation of pulsator. Air-bubble is created by the centrifugal force, and rises up.



## 6. DIRECTIONS FOR DISASSEMBLY AND ADJUSTMENT

### Warning

BEFORE ATTEMPTING TO SERVICE OR ADJUST ANY PART OF THE WASHING MACHINE, DISCONNECT THE POWER CORD FROM THE ELECTRIC OUTLET.

### Gear Mechanism Ass'y Replacement

- i Raise the top plate on the outer cabinet.
- i Remove outer tub cover from the tub ass'y.

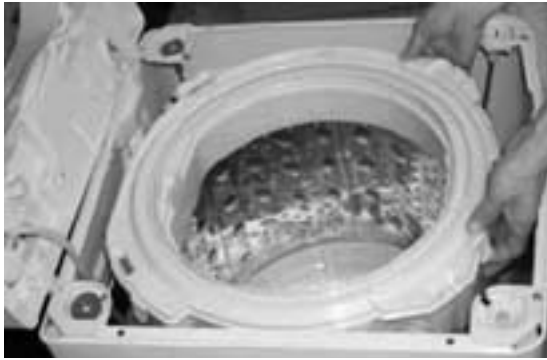

- i Loosen the pulsator mounting screw and remove the pulsator.



- i Remove the spinner shaft flange nut by using 'T' type box wrench.



- i Remove the tub ass'y.



### NOTES

To assemble the gear mechanism ass'y, reverse the disassembly procedure.

- ; Lay the front of the washer on the floor.
- ; Remove four bolts mounting the plate-gear protect by using a box wrench and remove plate-gear protect.
- ; Remove the V-belt.



- ; Remove four bolts mounting the gear mechanism ass'y by using a box wrench.



- ; Pull out the gear mechanism assy.



## Motor Synchronous And Valve Replacement(Non Pump Model )

- ; Lay the front of the floor.
- ; Loosen two special screw and motor synchronous.



- ; Take out the wire of motor synchronous from the bracket.
- ; Separate the motor synchronous from the base.



- ; Turn the valve by using screw driver as shown in picture.



- ; Remove the valve lid from the valve drain assy.

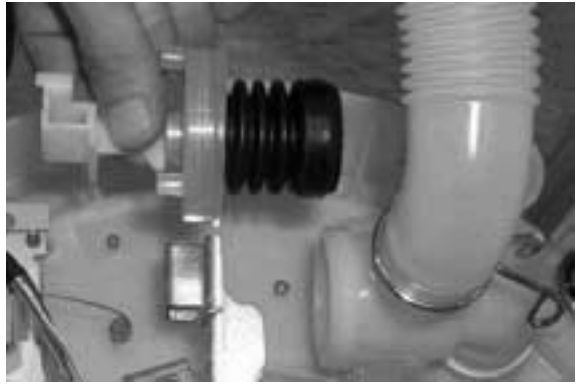

## Brake Adjustment

- ; Loosen the adjustment bolt and turn the adjustment bolt until the end of the bolt touches to the brake lever.
- ; Tighten the lock nut and apply a small amount of paint-lock.

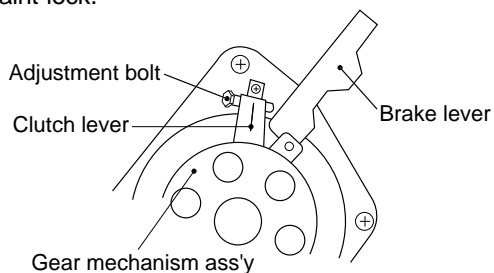

### NOTES:

1. The brake adjustment has been made at the factory, so that it is not re-adjust. However, in case of insufficient brake operation, problem the upper procedure.
2. Overtightening of the adjustment bolt will cause poor brake performance.
3. Undertightening of the adjustment bolt will cause continuous braking and thereby, cause the problems of the motor during the spingcycle.

## 7. THE REPAIR METHOD OF GEAR MECHANISM FOR CLUTCH SPRING PROBLEM

### The Structure Of Gear Mechanism

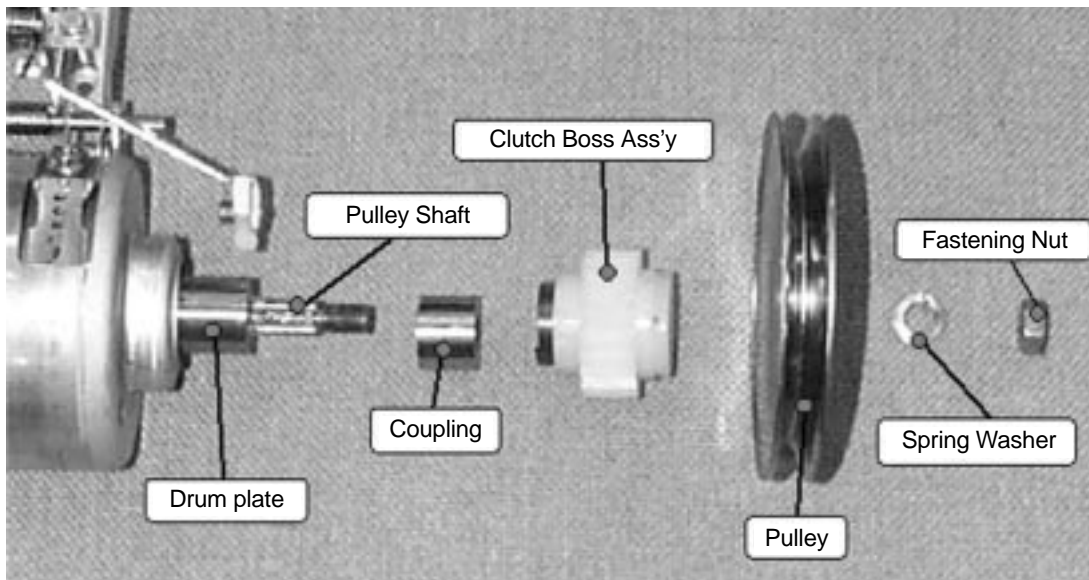
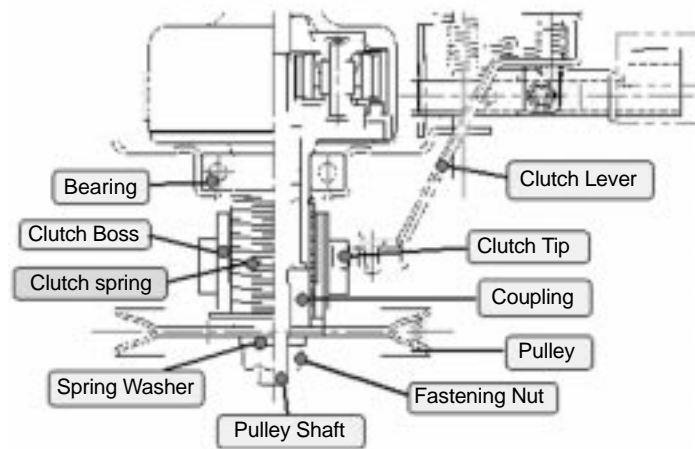

#### TOOL FOR REPLACING THE CLUTCH BOSS ASSEMBLE

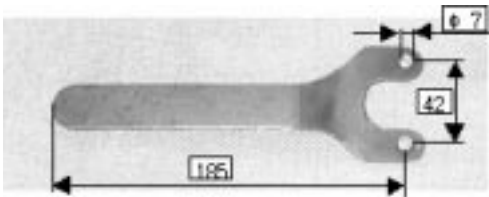
Tool name	Specification	Q'ty
Fixing jig		1
Ratchet handle		1
Socket and extension bar	socket : 10mm, 17mm	per each
Some cotton yarn		some

## How To Check The Clutch Spring Problem

### PROBLEM

- 1) THE LAUNDRY IS IN THE SPIN TUB UNEVENLY WHEN JUST STARTING SPIN PROCESS.
- 2) THEREFORE, IT CAUSE THE SERIOUS NOISE AND VIBRATION WHEN WASHING AND SPINNING PROCESS OR SUPPLING WATER IRREGULARLY WHEN SPINNING PROCESS AND CAUSE SHORT OF SPIN PERFORMANCE.

### CHECKING METHOD

IN THIS CASE, YOU MUST EMPTY THE SPIN TUB FIRST.

- 1) TO CHECK THE REVOLUTION OF SPIN TUB. IF THE SPIN TUB DOES NOT REVOLVE AND ONLY THE PULSATOR IS TURNING, THAT IS CLUTCH SPRING DEFECT.
- 2) TO CHECK THE SPIN SPEED(RPM) BETWEEN SPIN TUB AND PULSATOR. IF YOU FIND THE DIFFERENT SPIN SPEED BETWEEN SPIN TUB AND PUSATOR, THIS IS ALSO CLUTCH SPRING DEFECT.

IN THIS CASE, WE ARE GOING TO SUPPLY THE CLUTCH BOSS ASSEMBLY INSTEAD OF GEAR MECHANISM ASSEMBLY. PLEASE REFER TO FOLLOWING FIG.

### THE CLUTCH BOSS ASSEMBLY

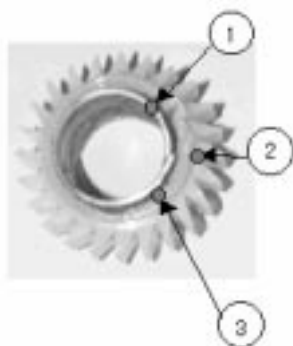



NO.	PARTS NAME	SPECIFICATION	CODE	Q'TY
1	CLUTCH SPRING	1.5*1.5	3615110000	1
2	CLUTCH BOSS	PP	3619301300	1
3	GREASE	beacon#325 3g		
PACKING METHOD	PACKING THE CLUTCH BOSS ASS'Y BY USING VINYL PACK			1

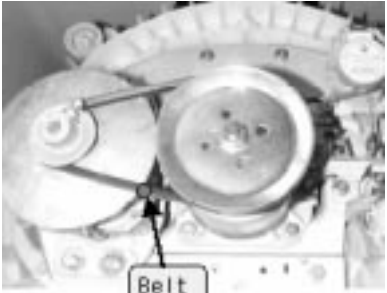

CLUTCH BOSS ASS'Y PART CORD : 3610028000

# The Process Of Disassembly

## Disassemble 1



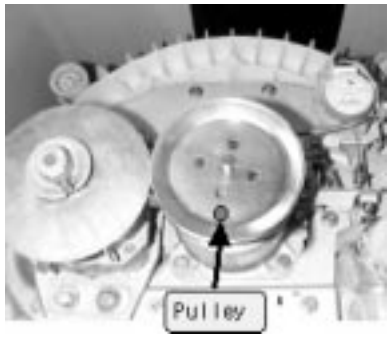

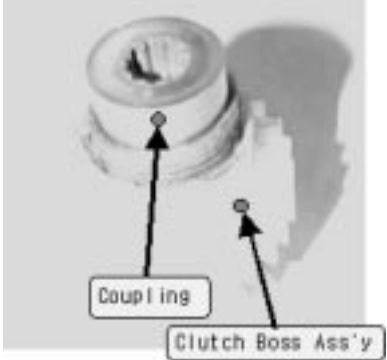
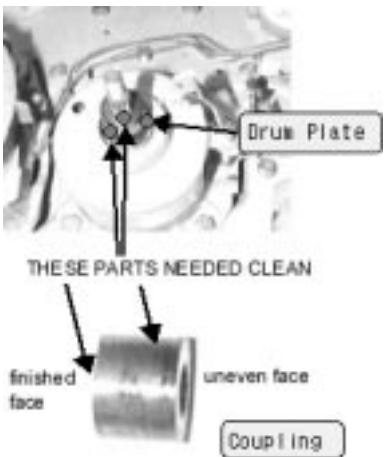
No.	Process	Notice
1	 <p data-bbox="245 786 619 819">Release screws marked 4-point</p>	<p data-bbox="1046 443 1310 566">Use wrench or driver - ratchet handle - extension bar - socket : 10mm</p>
2	 <p data-bbox="363 1160 443 1205">Belt</p>	
3	 <p data-bbox="371 1597 547 1641">Fastening Nut</p>	<p data-bbox="1046 1279 1445 1379">Use fixing jig for pulley as to see fig 1. and 17mm-socket for nut</p>
4	 <p data-bbox="355 2000 515 2045">Spring Washer</p>	<p data-bbox="1046 1715 1414 1749">Take out plain washer if it has</p>

Disassemble 2

No.	Process	Notice
5	 <p>Disassemble the pulley</p>	
6	 <p>Disassemble the clutch boss assembly</p>	<p>Catch the boss and pull upward with spiral rotate in the clockwise direction</p>
7	 <p>Separate coupling from clutch boss ass'y</p>	
8	 <p>Cleaning</p>	<p>Clean the drum plate, coupling surface and contact face between drum plate and coupling</p> <p>It is necessary to keep cotton piece goods being dry and clean</p>

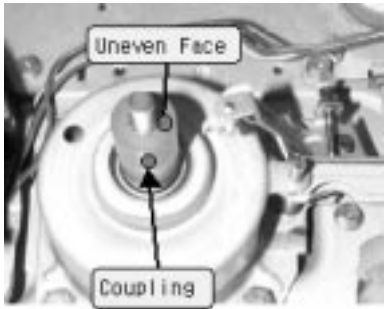
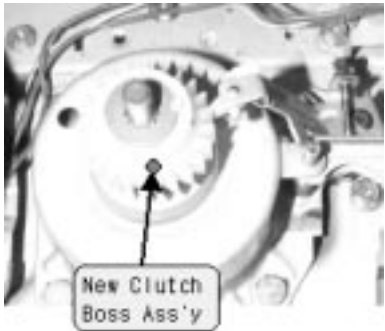

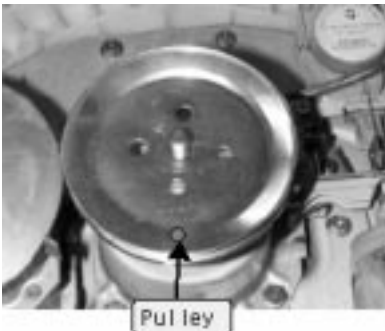
# The Process Of Assembly

## Assemble 1

No.	Process	Notice
1		<p>Assemble the coupling</p> <p>Check the uneven face of coupling is assembled upward</p>
2		<p>Assemble the new clutch boss ass'y</p> <ul style="list-style-type: none"> <li>- Push in the clutch boss ass'y with rotating on the clockwise direction.</li> <li>- After assembling, rotate on the clockwise more 2~3 teeth and pull out the pulley shaft upward</li> </ul> 
3		<p>Assemble the pulley</p>
4		<p>Assemble the spring washer</p> <p>If there was plain washer, you have to assemble plain washer the first and then assemble spring washer</p>

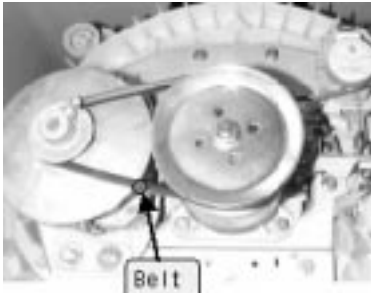
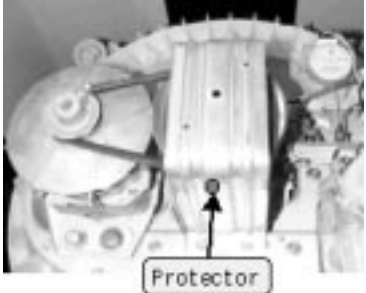
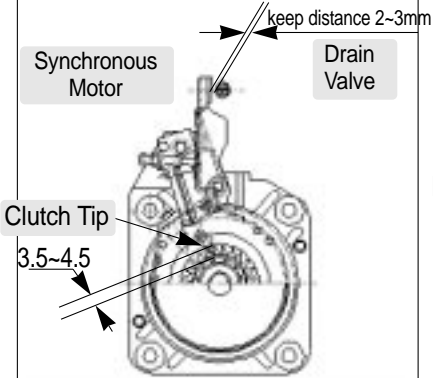

Assemble 2

No.	Process	Notice
5	 <p>Assemble the fastening nut</p>	<p>- Use fixing jig and 17mm socket wrench as if disassembling, as fastening torque about 100~200kgf-cm.                      - Check the end-play, up and downward and check the binding force, too much or not on bi-direct of rotation.</p> 
6	 <p>Assemble the Belt</p>	
7	 <p>Assemble the protector</p>	
8	 <p>Final checking</p>	<p>Finally, check the distance between brake lever and control bolt. (2~3mm)                      Also, check the interference depth both clutch tip and clutch boss(3.5~4.5mm)</p>

# 8. TROUBLE SHOOTING GUIDE



## NOTES

1. When replace the P.C.B. ASS'Y do not scratch the surface of the P.C.B. ASS'Y.
2. Disconnect the power cord from the electric outlet.

## Concerning Water Supply

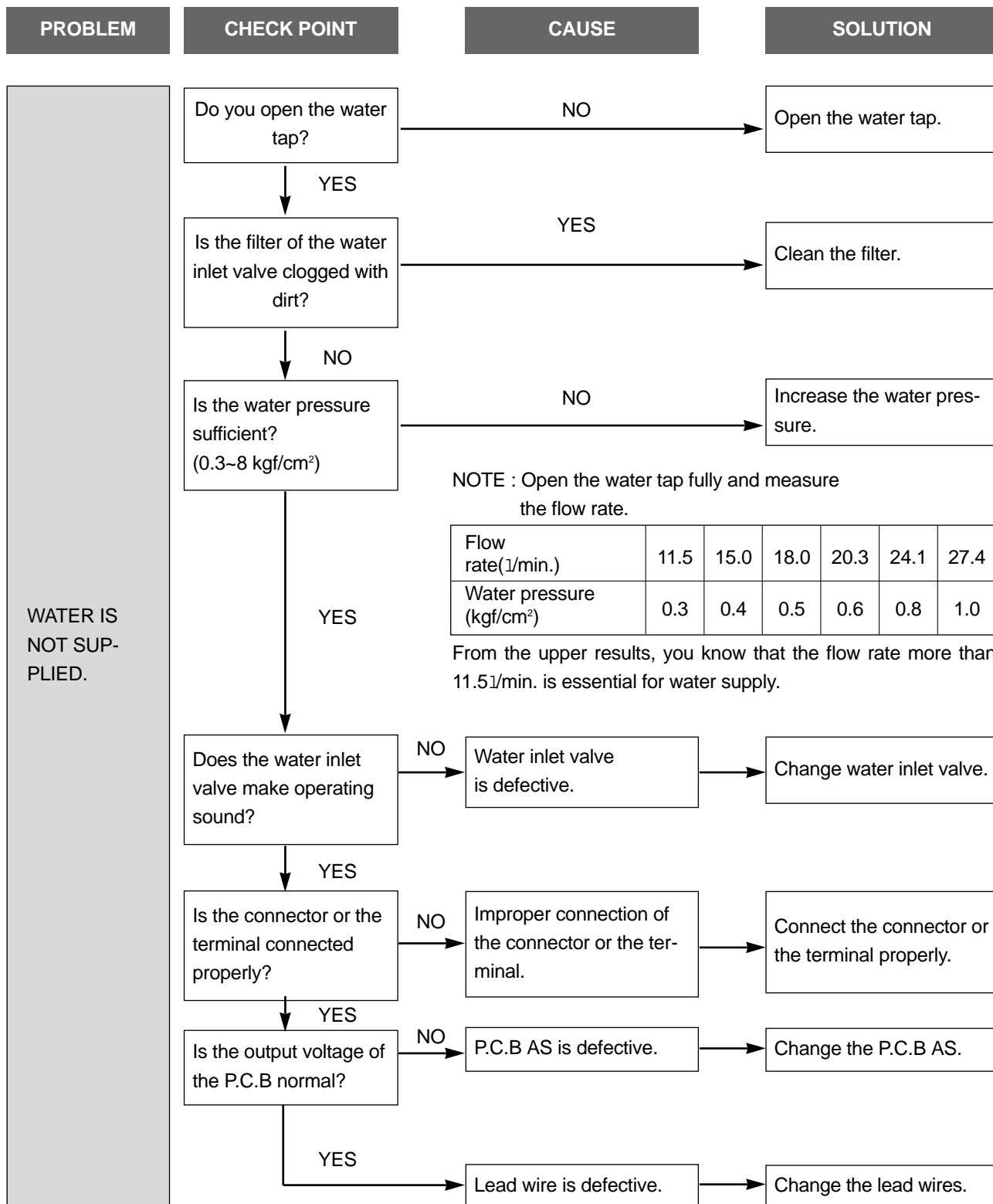

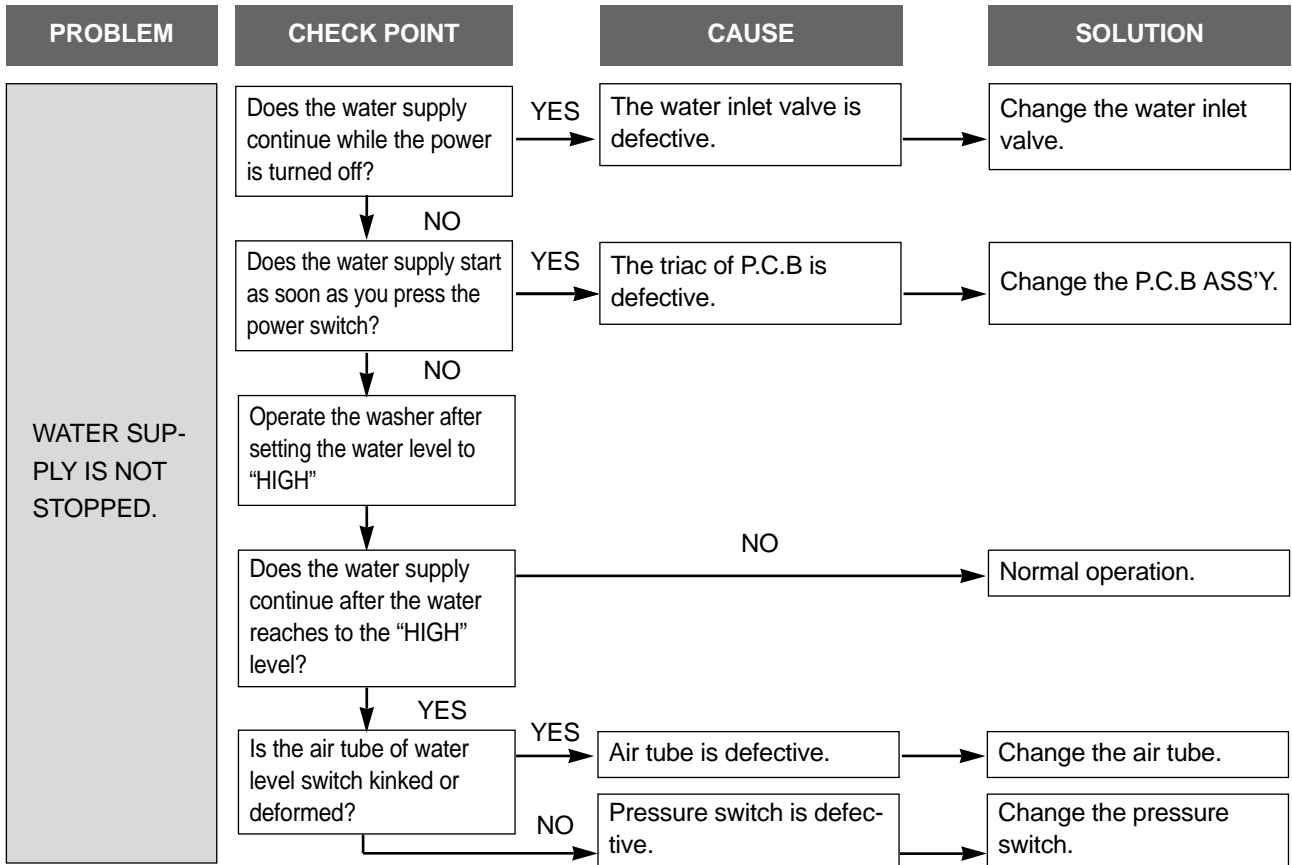

## Concerning Washing

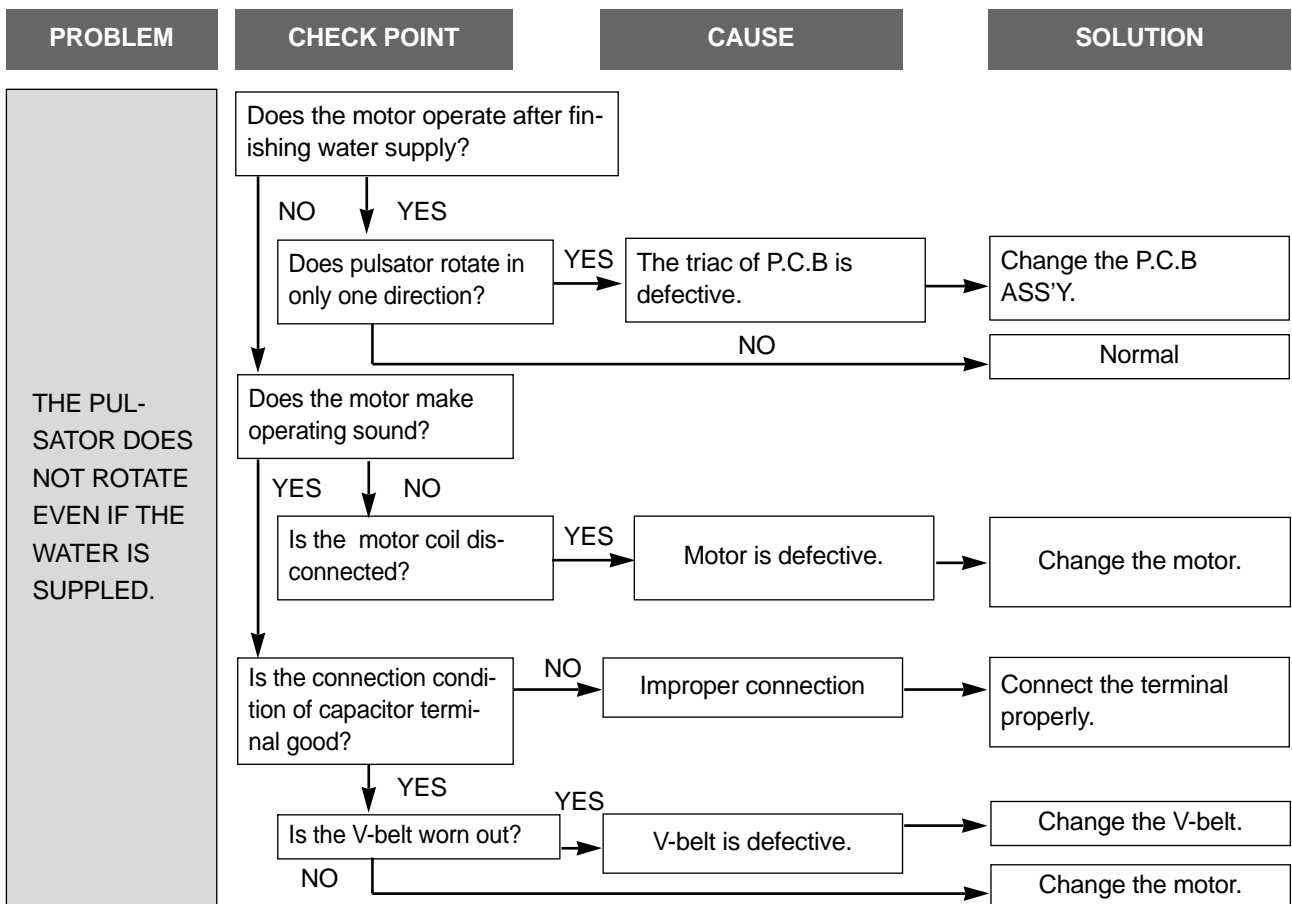

## Concerning Draining

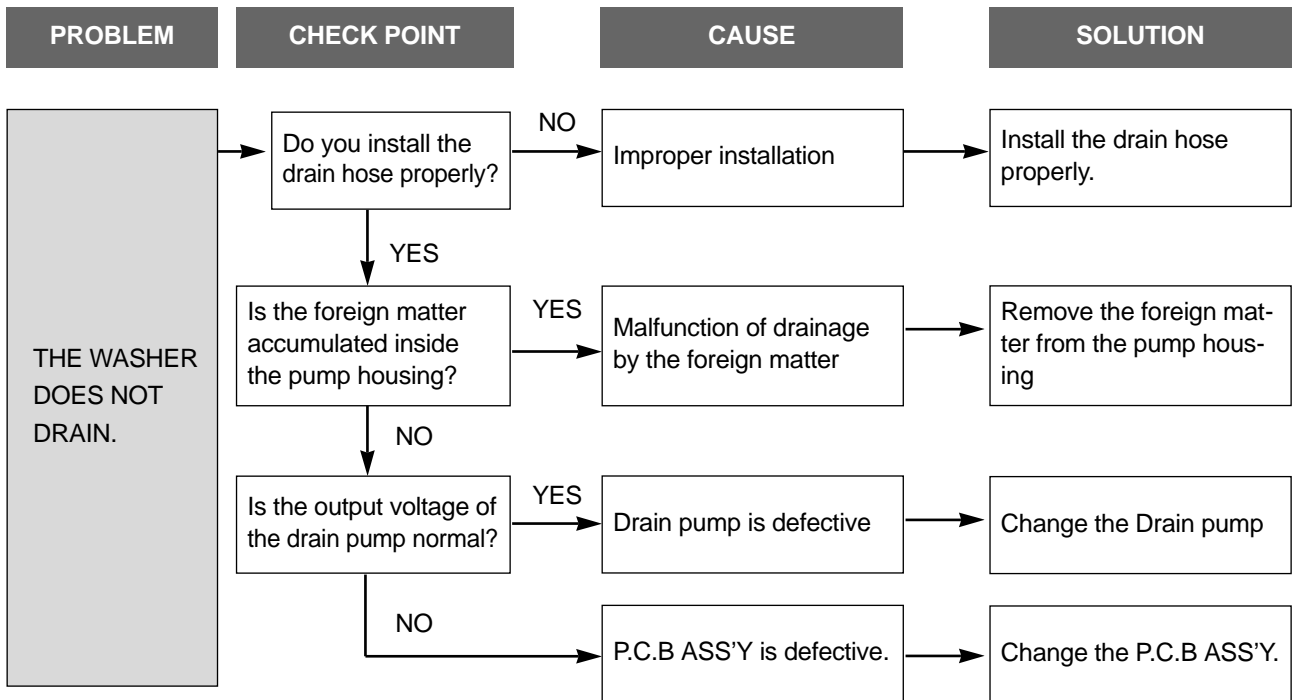

## Concerning Spinning







PROBLEM	CHECK POINT	CAUSE	SOLUTION
THE WASHER DOES NOT SPIN.	Is the lid open?	YES	Close the lid.
	Does the safety switch operate normally?	NO	Safety switch is defective. Change the safety switch.
	Is the connector of P.C.B ASS'Y connected properly?	NO	Improper connection of the connector. Connect the connector properly.
	Does the pulsator rotate while the tub does not rotate?	YES	P.C.B. ASS'Y is defective. Change P.C.B ASS'Y.
	Is the input voltage of the drain motor normal?	YES	Drain motor is defective. Change the drain motor.
	Is the V-belt worn out?	YES	V-belt is defective. Change the V-belt.
	Is the input voltage of motor normal?	YES	Motor is defective. Change the motor.
	Is the connection condition of capacitor terminal good?	NO	Improper connection. Connect the terminal correctly.
		YES	P.C.B ASS'Y is defective. Change the P.C.B ASS'Y.

## Concerning Operation

PROBLEM	CHECK POINT	CAUSE	SOLUTION	
<p>THE INDICATOR LAMPS(L.E.D) DO NOT LIGHT UP WHEN THE POWER BUTTON IS PRESSED.</p>	<p>Is the plug connect-ed to electric outlet?</p>	NO	<p>Connect the plug.</p>	
	↓ YES			
	<p>Is Fuse opened?</p>	YES	<p>Change Fuse</p>	
	↓ NO			
	<p>Is the condition of power button good?</p>	NO	<p>Power button is defective</p>	<p>Change P.C.B ASS'Y.</p>
↓ YES				
<p>Is the connector of the P.C.B. ASS'Y connect-ed properly?</p>	NO	<p>Improper connection of the connector.</p>	<p>Connect the connector properly.</p>	
↓ YES		<p>P.C.B. ASS'Y is defec-tive.</p>	<p>Change P.C.B ASS'Y.</p>	
<p>PROGRESS LAMPS(LED) DO NOT LIGHT UP.</p>	<p>Do you press START/HOLD button?</p>	NO	<p>Press START/HOLD but-ton.</p>	
	↓ YES		<p>P.C.B ASS'Y is defective.</p>	<p>Replace P.C.B ASS'Y.</p>
<p>MOTOR ROTATES WHEN START/HOLD BUTTON IS NOT PRESSED.</p>	<p>Does the pressure switch operate normally?</p>	NO	<p>Pressure switch is defec-tive.</p>	<p>Change the pressure switch.</p>
	↓ YES			
	<p>Check the output voltage of P.C.B ASS'Y</p>	Abnormal	<p>P.C.B ASS'Y is defective</p>	<p>Change P.C.B ASS'Y.</p>
<p>ABNORMAL NOISE DUR-ING WASH PROCESS.</p>	<p>Is the strange noise gener-ated when the pulsator rotates in TEST MODE of P.C.B ASS'Y?</p>	YES	<p>There is foreign matter between pulsator and tub.</p>	<p>Remove the foreign mat-ter.</p>
	↓ NO			
	<p>Is the V-belt worn out?</p>	YES	<p>V-belt is defective.</p>	<p>Change the V-belt.</p>

## 9. PRESENTATION OF THE P.C.B ASS'Y

### Concerning Error Message

MESSAGE	CAUSE	SOLUTION
	Improper installation of drain hose.	Install drain hose properly.
	The drain hose is blocked up by foreign matter.	Remove foreign matter from drain hose.
	Drain motor is inferior.	Change drain motor.
	The water tap is closed.	Open the water tap.
	The water inlet filter clogged.	Clean the water inlet filter.
	It passes over the 30 minutes, yet it doesn't come to assigned water level.	Check whether or not is comes to the assigned water level.
	Wash loads get uneven during spin.	Re-set wash loads evenly.
	Poor installation of the unit.	Proper installation.
	The lid is opened.	Close the lid.
	The safety switch is inferior.	Change the safety switch.
	The load sensing is inferior. After the load sensing operates about 7 seconds, the message is displayed during 1 second and water level is always fixed 'high'.	Change the P.C.B. ASS'Y.
	The water level sensing is inferior.	Check the water level sensor and the contact part of the connector.

Wiring Diagram [non-pump]

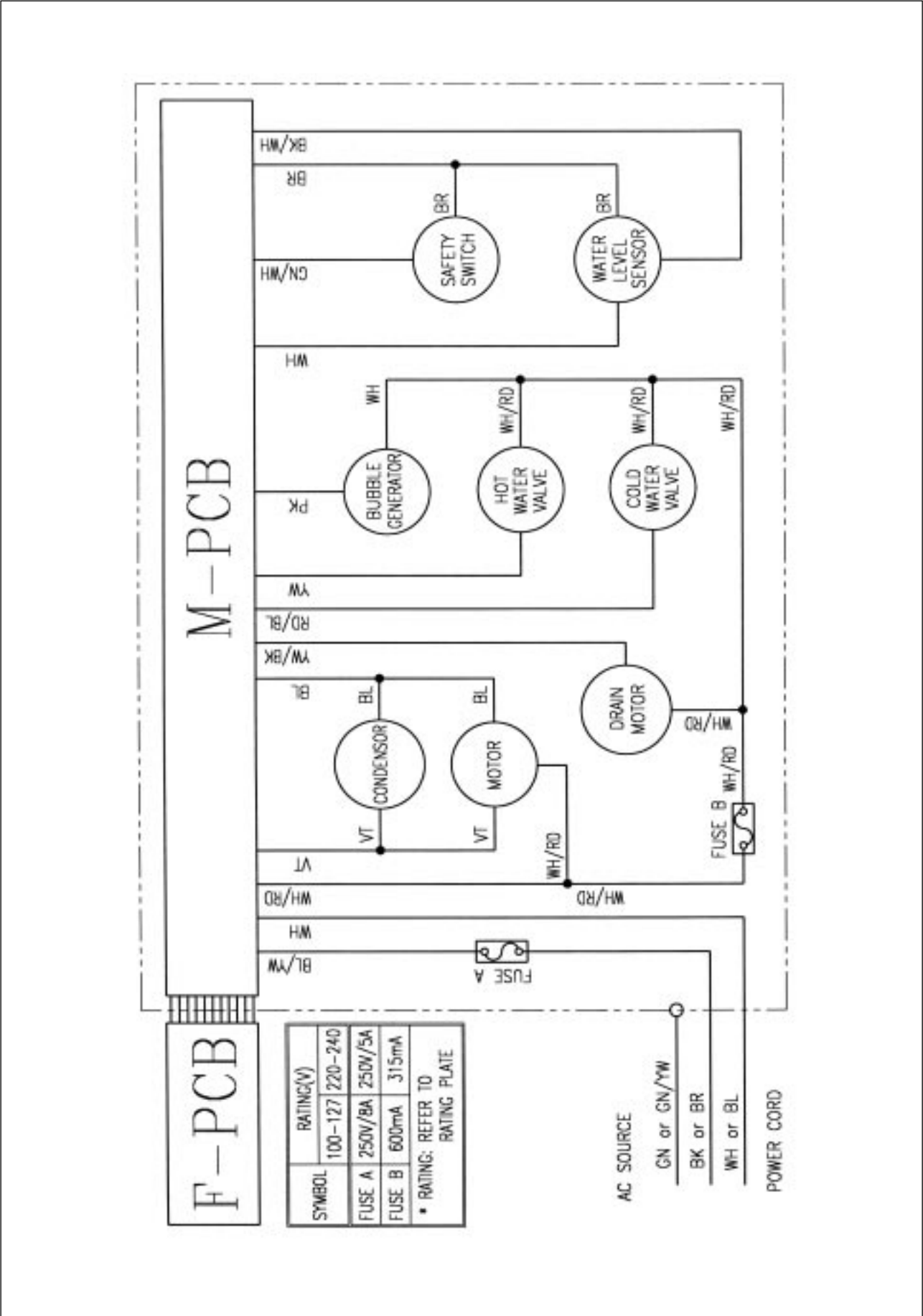



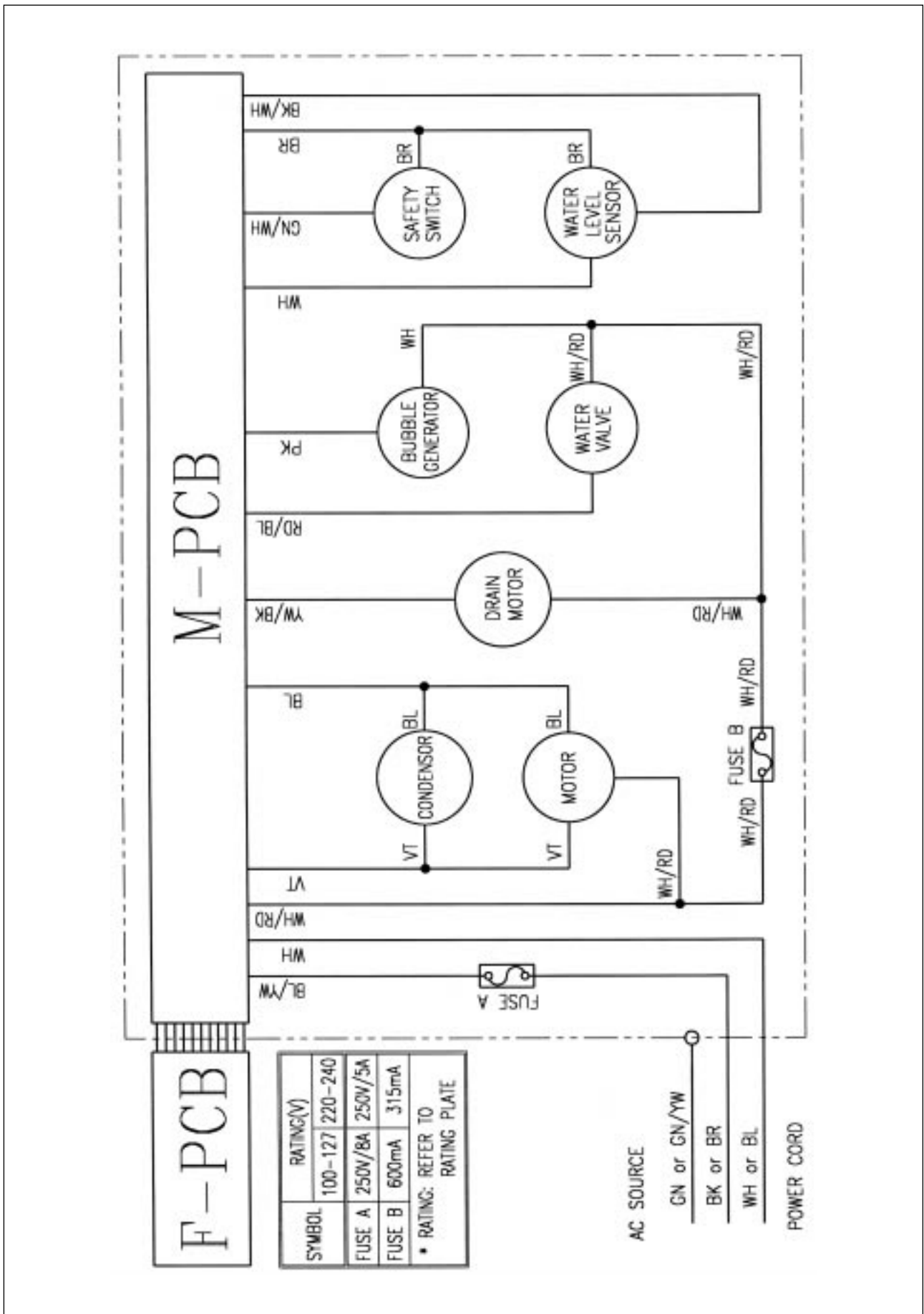

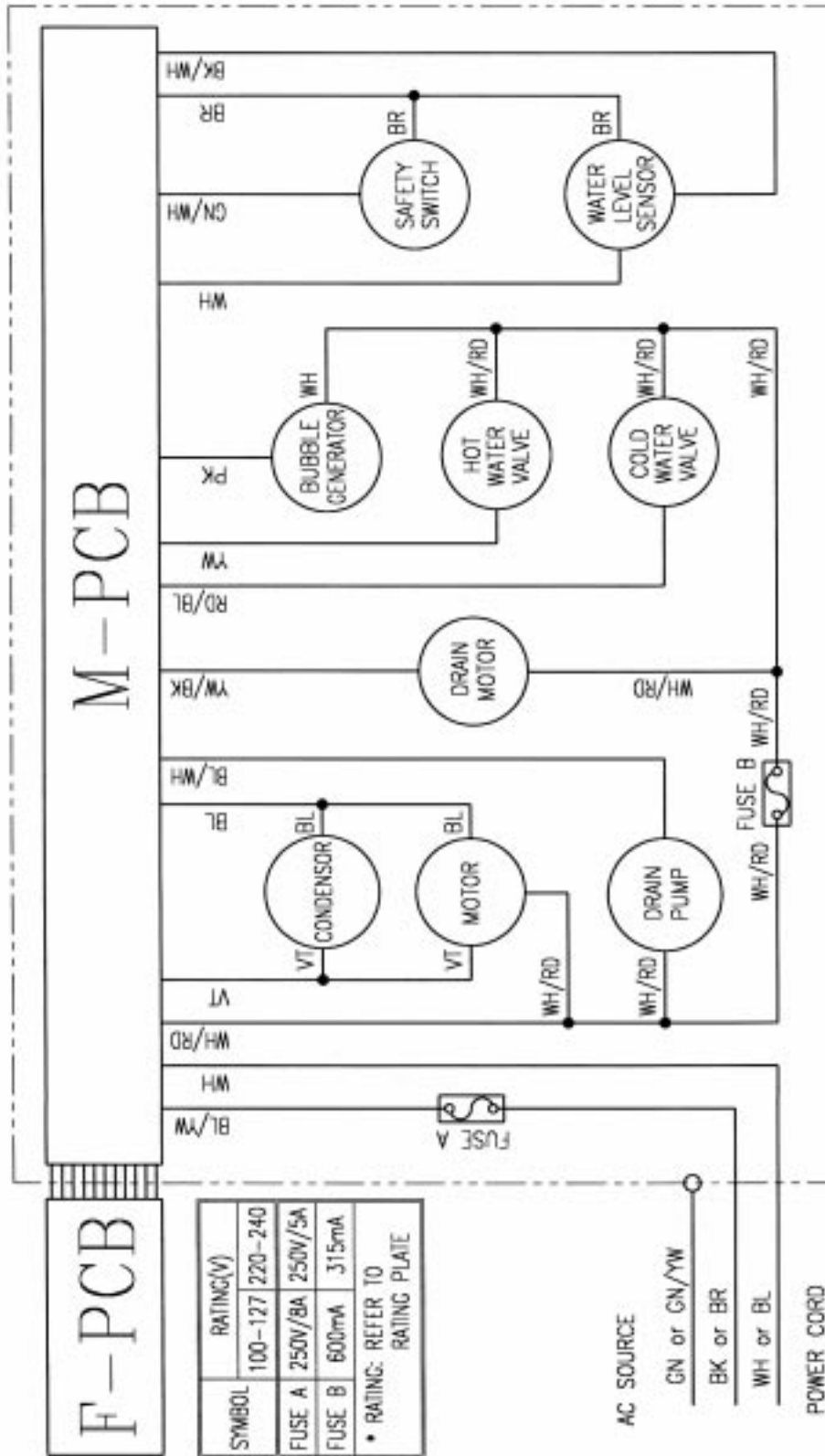

SYMBOL	RATING(V)	
		100-127
FUSE A	250V/BA	250V/5A
FUSE B	600mA	315mA

• RATING: REFER TO RATING PLATE

AC SOURCE  
 GN or GN/YW  
 BK or BR  
 WH or BL  
 POWER CORD

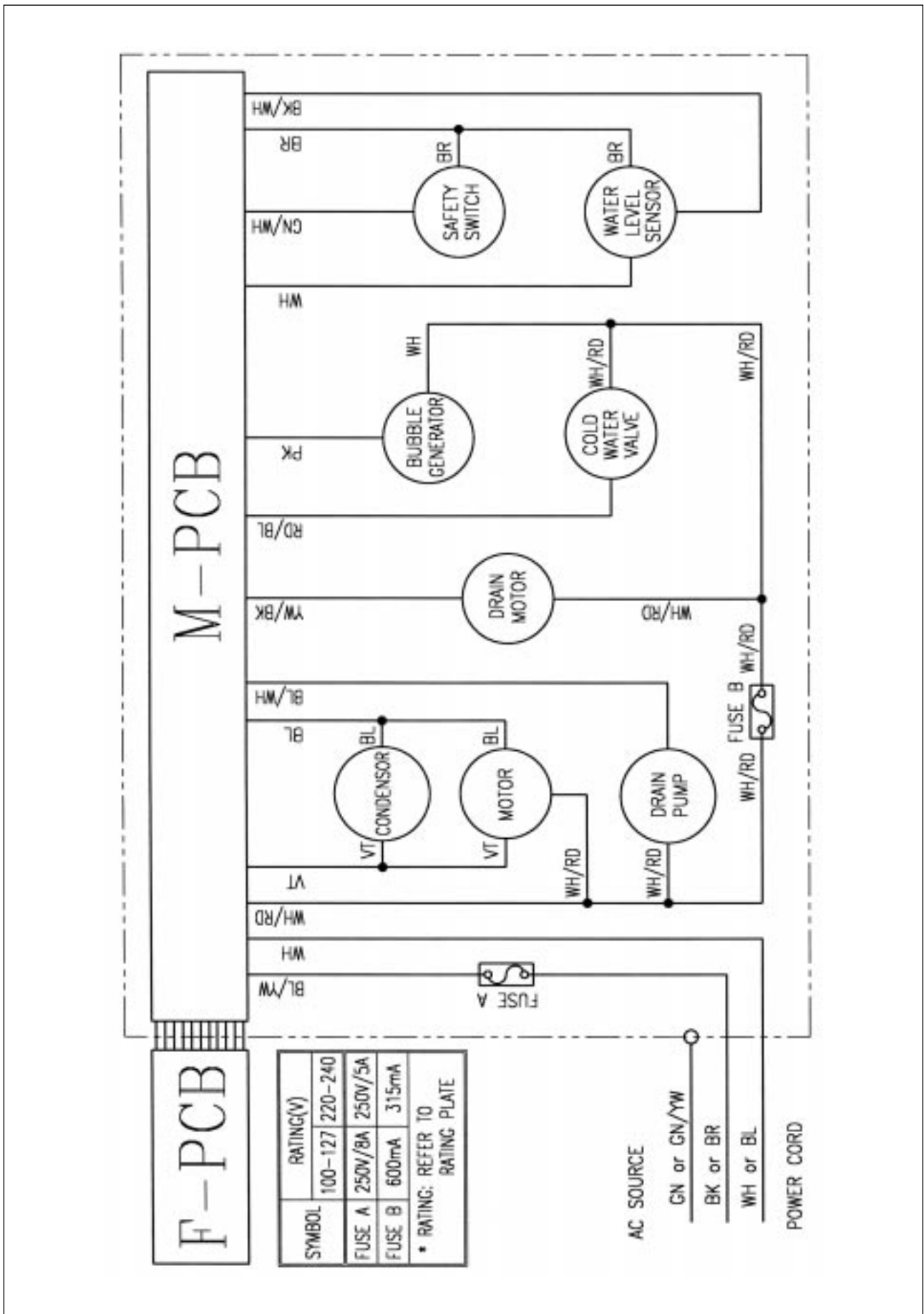

# § Parts Diagram

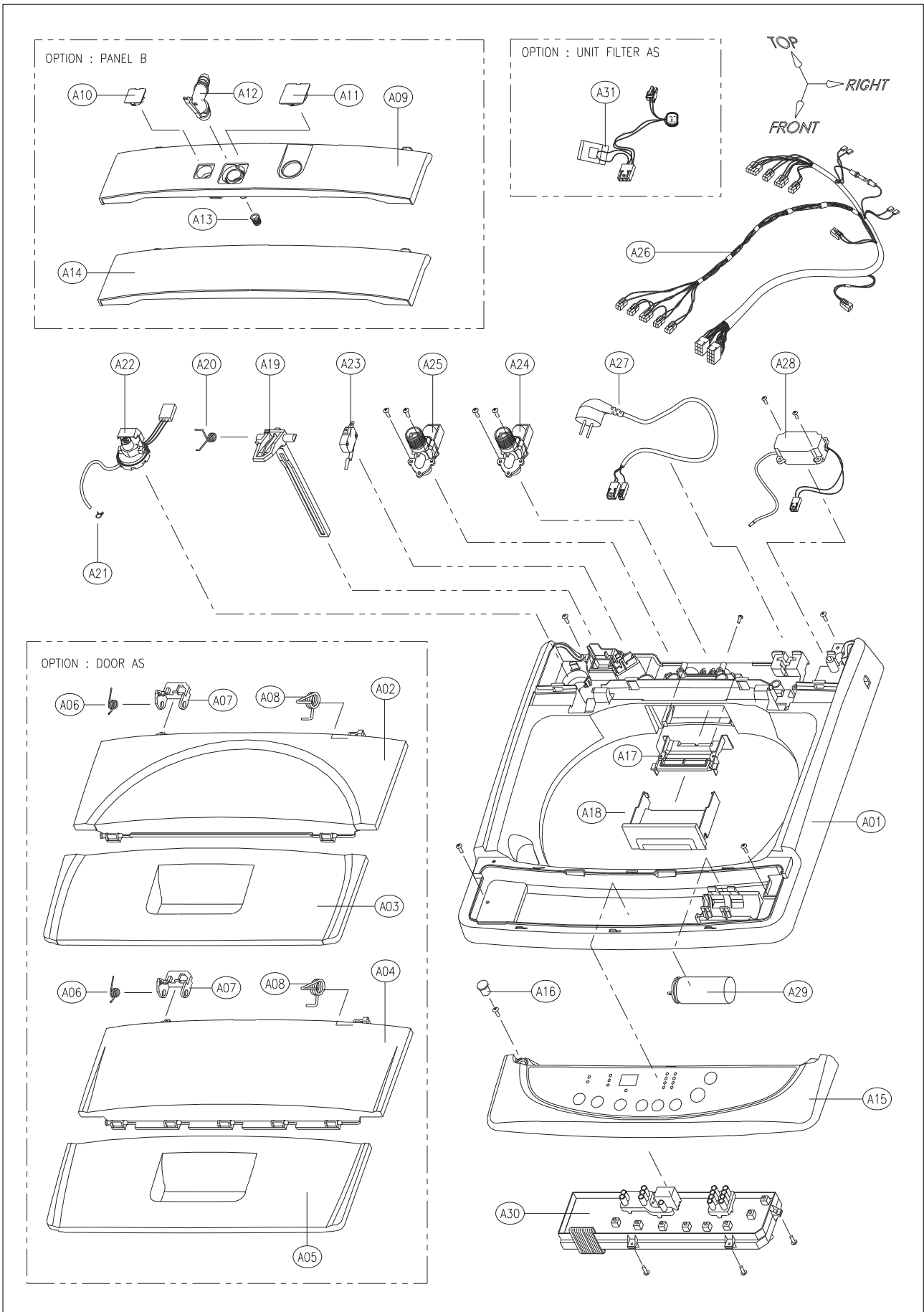

✓ **Caution:** In this Service Manual, some parts can be changed for improving, their performance without notice in the parts list. So, if you need the latest parts information, please refer to PPL(Parts Price List) in Service information Center(<http://svc.dwe.co.kr>)

## Parts List

NO.	PART NAME	PART CODE	SPECIFICATION	REMARK
A01	PLATE T	3614521500	PP	
A02	DOOR B AS	3611797600	ABS	OPTION :
A03	DOOR F AS	3611797700	ABS	TRANSPARENT
A04	DOOR B	3611797300	PP	OPTION :
A05	DOOR F	3611797400	PP	NOT TRANSPARENT
A06	SPRING PLATE LEVER	3615111800	SUS	
A07	PLATE LEVER	3614521400	PP	
A08	SPRING DOOR	3615112100	SUS D1.4	
A09	PANEL B	3614233400	PP	
A10	CAP WATER	-	PP	
A11	CAP DRY	-	PP	OPTION :
A12	CONNECTOR HOSE	3619506600	PS	UPWARD WATER VALVE
A13	PACKING	3614004100	SILICON	
A14	PANEL B	3614233600	PP	OPTION : BACKWARD
A15	PANEL F	3614233500	ABS	DWF-750/752/800/802
		3614235610	ABS	DWF-753/755/803/805
		3614235600	ABS	DWF-756/758/806/808
A16	CAP REAR	3610902600	CR	
A17	NOZZLE DETERGENT	3618102600	PP	
A18	CASE DETERGENT	3611130700	PP	
A19	LEVER SAFETY S/W	3613701800	POM	
A20	SPRING LEVER SAFETY	3615111700	SUS D1.0	
A21	CLAMP	4507D08150	MFZN HOSE ID=7PIE	
A22	SENSOR PRESSURE AS	3614801300	CDN-D6N	
A23	SWITCH COVER AS	4507K44031	15A 220VAC 1006FD	
A24	VALVE INLET	3615403510	AC 110-130V/50,60Hz COLD	BACKWARD
		3615402010	AC 220V/60Hz COLD	
		3615403711	AC 220-240V/50Hz COLD	
		3615403530	AC 110-130V/50,60Hz COLD	UPWARD
		3615402030	AC 220V/60Hz COLD	
A25	VALVE INLET	3615403630	AC 110-130V/50,60Hz HOT	BACKWARD
		3615402130	AC 220V/60Hz HOT	
		3615403831	AC 220-240V/50Hz HOT	
A26	HARNES AS	3612787910	8A COLD NON-BUBBLE	SINGLE VALVE DWF-750/752/800/802
		3612787915	5A, COLD NON-BUBBLE	
		3612787920	8A COLD BUBBLE	
		3612787925	5A COLD BUBBLE	
		3612787950	8A COLD NON-BUBBLE	SINGLE VALVE DWF-753/755/803/805 DWF-756/758/806/808
		3612787955	5A, COLD NON-BUBBLE	
		3612789600	8A COLD BUBBLE	
		3612787965	5A COLD BUBBLE	
		3612787930	8A COLD/HOT BUBBLE	DUAL VALVE, PUMP
		3612787935	5A COLD/HOT BUBBLE	
		3612787940	8A COLD/HOT NON-BUBBLE	

✓ **Caution:** In this Service Manual, some parts can be changed for improving, their performance without notice in the parts list. So, if you need the latest parts information, please refer to PPL(Parts Price List) in Service information Center(<http://svc.dwe.co.kr>)

NO.	PART NAME	PART CODE	SPECIFICATION	REMARK
A26	HARNESS AS	3612787945	5A COLD/HOT NON-BUBBLE	DUAL VALVE, PUMP
		3612787970	8A COLD/HOT BUBBLE	DUAL VALVE
		3612787975	5A COLD/HOT BUBBLE	
		3612787980	8A COLD/HOT NON-BUBBLE	
		3612787985	5A COLD/HOT NON-BUBBLE	
A27	CORD POWER AS	3611337000	F H05VV 3X0.75 1.9M WH	CHILE
		3611337100	RVCTFK 2X0.75 1.9M GY	JAPAN
		3611337200	N LFC-3R 3X0.75 1.9M GY	AUSTRALIA
		3611337300	F H05VV 3X0.75 1.9M WH	ITALY
		3611337400	RW-300/500 3X0.75 1.9M	PR. CHINA
		3611337500	VCTF 3X0.75 1.9M	INDIA
		3611337600	U VCTF 3X0.75 1.9M GY	SOUTH KOREA
		3611337700	P VCTF 3X0.75 1.9M WH	KUWAIT
		3611337800	VCTF 3X0.75 1.9M WH	KUWAIT, OMAN
		3611337900	H05VV-F 3X0.75 1.9M WH	MALAYSIA
		3611338000	H05VV-F 3X0.75 1.9M	SINGAPORE
		3611338100	A-VCTFK 2X0.75 1.9M GY	TAIWAN
		3611338200	F H05VV 3X0.75 1.9M BK	EUROPEAN NATIONS
		3611338300	C SJT 3X18AWG 1.9M GY	PANAMA, USA
		3611338400	H05VV-F 3X0.75 1.9M GY	ARGENTINA
3611338500	H05VV-F 3X0.75 1.9M GY	SOUTH AFRICA		
3611338600	P VCTF 3X0.75 1.9M WH	OMAN		
A28	UNIT BUBBLE AS	3618946301	AC220-240V L=750 PAD	OPTION
		3618906401	AC110-130V L=750 PAD	
A29	UNIT CAPACITOR	3618911600	8.4 $\mu$ F 400VAC CAN-TYPE	AC220-230V/50,60Hz
		3618911900	30 $\mu$ F 200VAC CAN-TYPE	AC120-127V/60Hz
		3618912000	33.6 $\mu$ F 200VAC CAN-TYPE	AC110V/60Hz
		3618959700	7.5 $\mu$ F 400VAC CAN-TYPE	AC240V/50Hz
A30	PCB AS	PRPSSWU602	802WT(T8-V1F)	DWF-750/752/800/802
		PRPSSWU603	752MN(T8-V2)	
		PRPSSWU701	750WTP(T8-V1)	
		PRPSSWU702	800WMP(T8-V2)	
		PRPSSWU704	750MNP(T8-V2F)	
		PRPSSWU703	800WMP(T8-V2F, AUSTRAL IA)	DWF-753/755/803/805
		PRPSSWU900	803MNP(T8-V2F)	
		PRPSSWU901	803MTC(T8-V1F)	
		PRPSSWU902	803MTP(T8-V1)	
		PRPSSWU903	803MNP(T8-V2)	
		PRPSSWU904	803MNP(T8-V2)	DWF-756/758/806/808
		PRPSSWU905	803MNP(T8-V2, AUSTRALIA)	
		PRPSSWU800	806MNP(T10-V2)	
		PRPSSWU801	806MTC(T10-V1)	
		PRPSSWU802	806MNC(T10-V2)	
PRPSSWU803	806MTP(T10-V1)			
A31	UNIT FILTER AS	3618961000	FILTER + COIL	OPTION
		3618961010	FILTER + COIL, THERMAL TUBE	

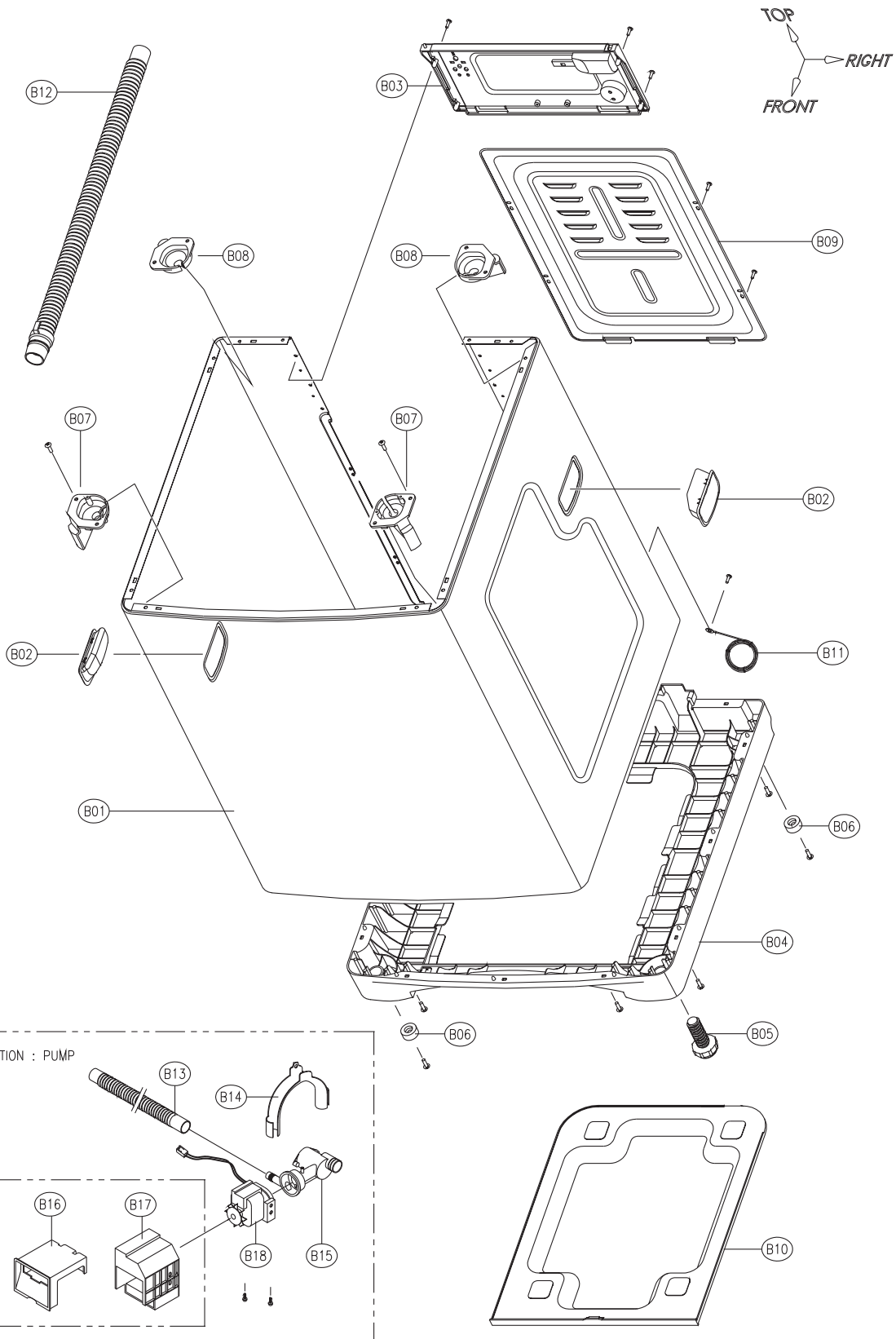





OPTION : TUB

TOP  
FRONT  
RIGHT

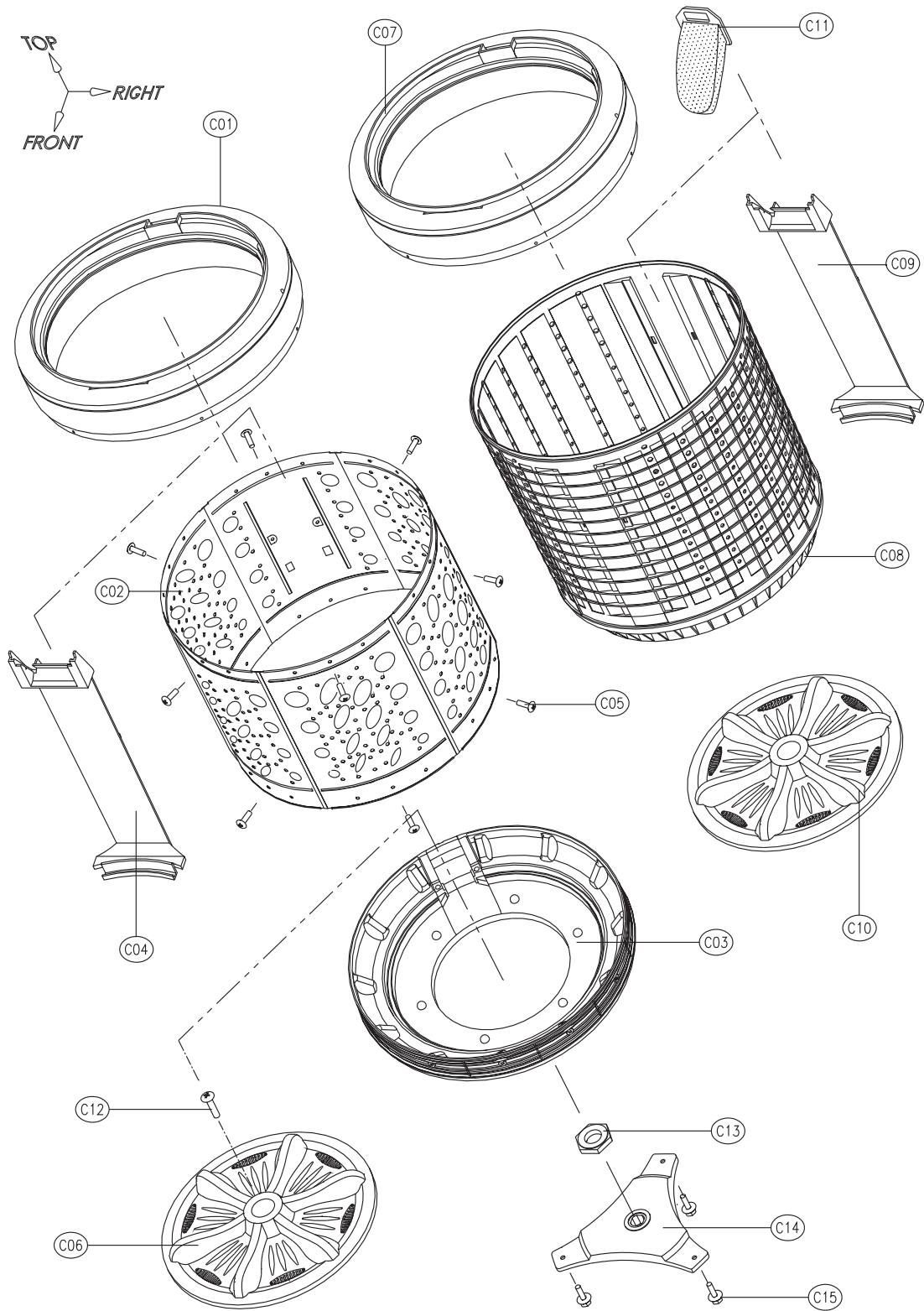



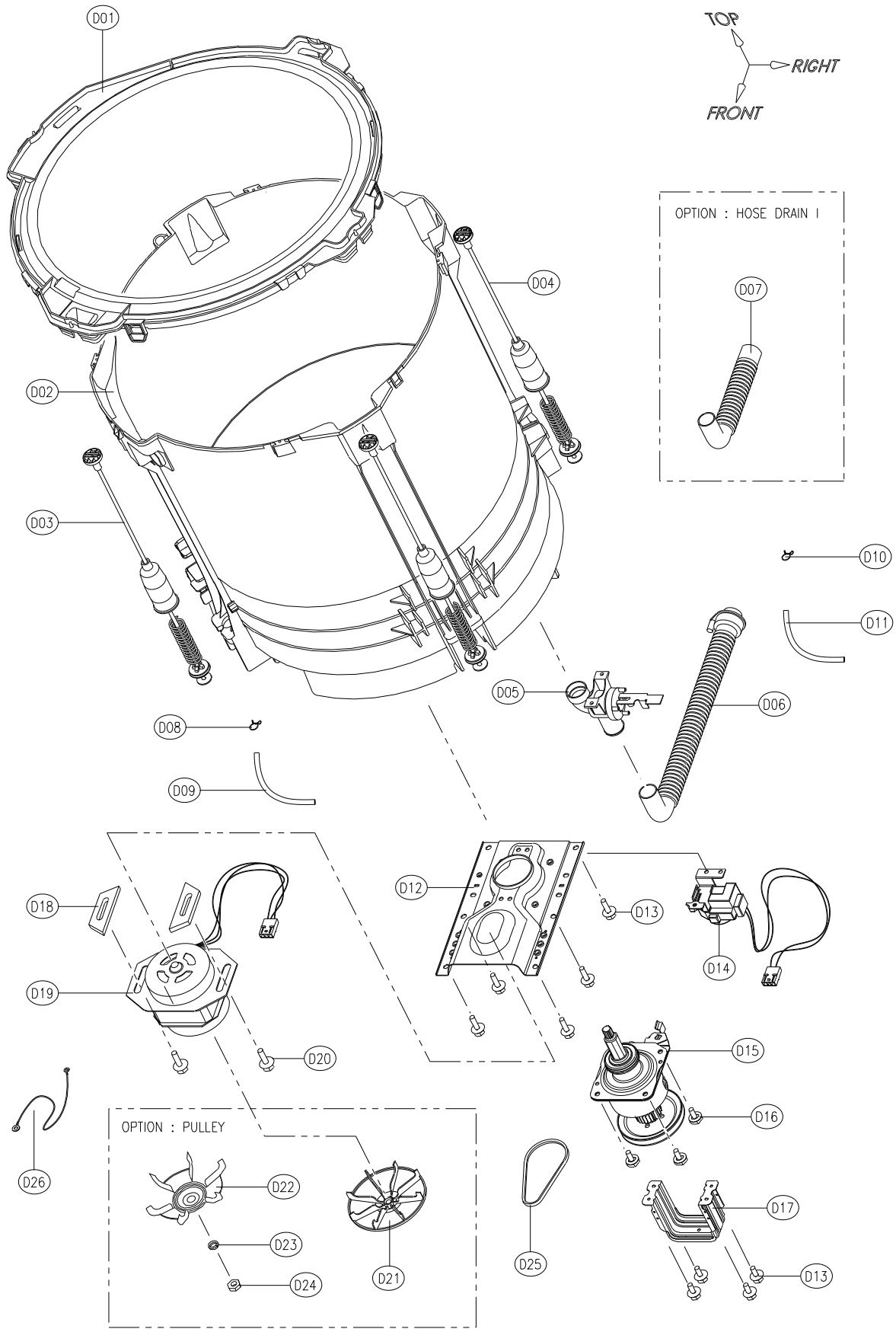

✓ **Caution:** In this Service Manual, some parts can be changed for improving, their performance without notice in the parts list. So, if you need the latest parts information, please refer to PPL(Parts Price List) in Service information Center(<http://svc.dwe.co.kr>)

## Parts List

NO.	PART NAME	PART CODE	SPECIFICATION	REMARK
D01	COVER TUB O	3611414600	PP	
D02	TUB O	3618817600	PP	
D03	SUSPENSION AS F	3619804200	FRONT	
D04	SUSPENSION AS B	3619804300	REAR	
D05	VALVE DRAIN AS	3615408500	DWF-750M	NON-PUMP
D06	HOSE DRAIN I AS	3613227000	LDPE+EVA DWF-752MN	
D07	HOSE DRAIN I AS	3613226900	LDPE+EVA DWF-800WNP	PUMP
D08	CLAMP	4507D08150	MFZN HOSE ID=7PIE	OPTION : PUMP
D09	HOSE	4500D08210	ID=4.0	
D10	CLAMP	4507D08150	MFZN HOSE ID=7PIE	OPTION : BUBBLE
D11	HOSE	4500D08210	ID=4.0	
D12	BASE	3610302900	SECEN 1.2T	
D13	SPECIAL SCREW	3616007000	SCM24H 6.5X24	
D14	MOTOR SYNCHRONOUS	3966010410	220-240V/50,60Hz ST=23	
		3966320830	110-127V/60Hz ST=23	
D15	GEAR MECHANISM	3617307310	GM-0600-KJ4P0	
D16	BOLT HEX	7640802011	6B-1 8X20 SW MFZN	
D17	PROTECTOR GEAR	3618303600	SGCC 1.2T	
D18	SPECIAL WASHER	4505E34030	PP	
D19	UNIT MOTOR AS	3618959900	110-127V/60Hz W1D30CC004	
		3618960100	220V/60Hz W1D0UC004	
		3608960200	220-240V/50Hz 30VC004	
D20	BOLT HEX	7650802511	6B-1 8X25 HS MFZN	
D21	PULLEY MOTOR AS	3618401420	DP=53.0 50Hz ALDC	OPTION
		3618402800	DP=48.5 60Hz ALDC	
D22	PULLEY MOTOR AS	3618431900	DP=53.0 50Hz PRESS	
		3618432000	DP=48.5 60Hz PRESS	
D23	WASHER SPRING	7401008011	SW-8 MFZN	
D24	NUT HEX	7392800011	M8XP1.25 MFZN	
D25	BELT V	4507D34020	M20	50Hz
		4507B34020	M19.5	60Hz
D26	HARNESS EARTH INNER	3612757010	L=560	



2. DWF-756/758/806/808

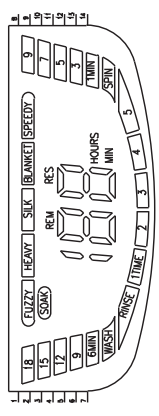
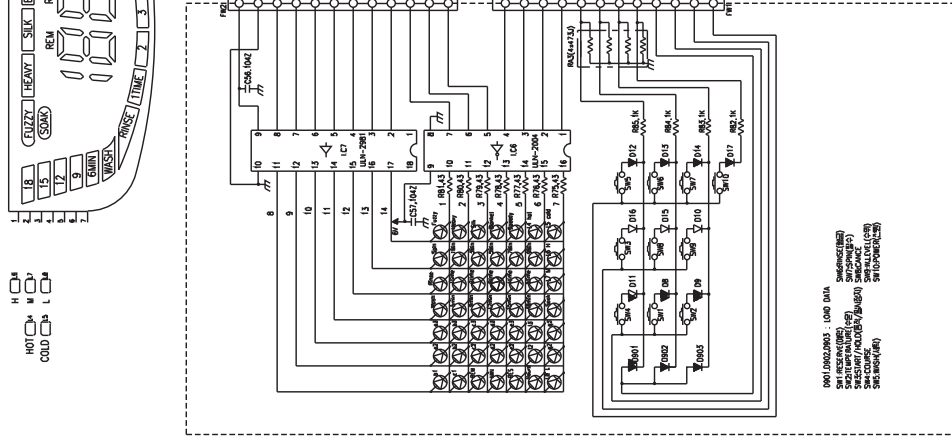
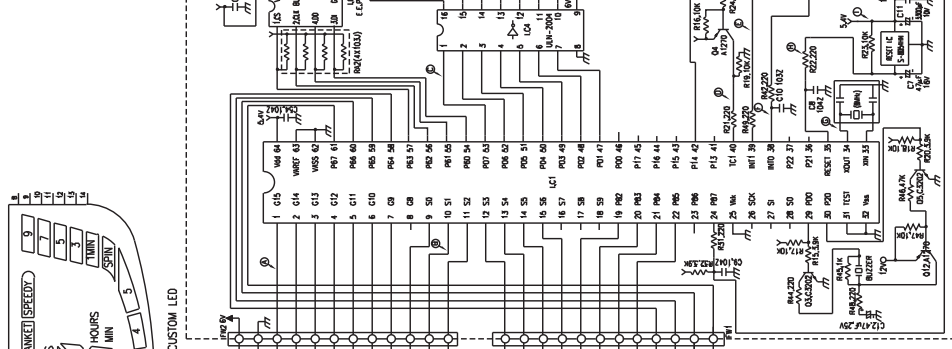
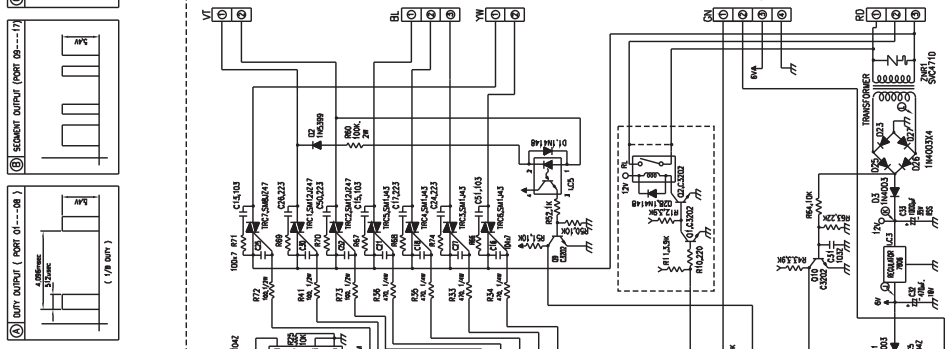
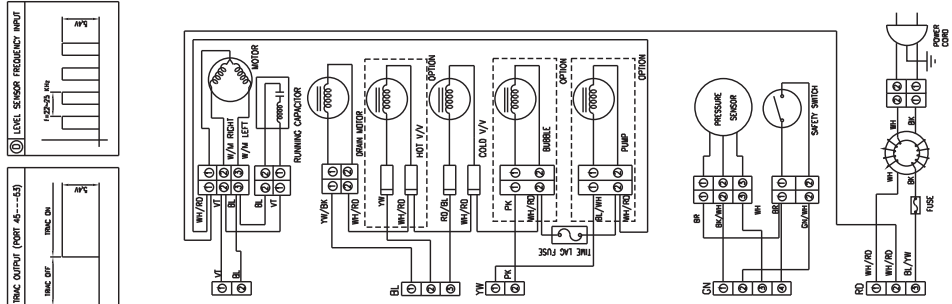
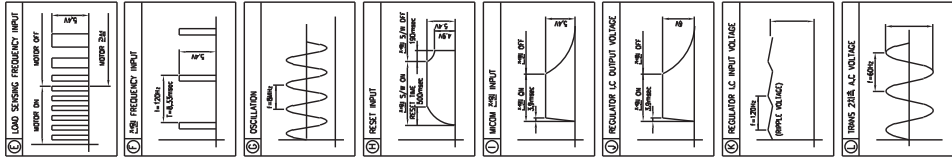

H  M   
 HOT  W   
 COLD  L

0001 J0022803 : LOAD DATA  
 SW (RESERVED) (RES)  
 SW (RESERVED) (RES)  
 SW (RESERVED) (RES)  
 SW (RESERVED) (RES)  
 SW (RESERVED) (RES)

**DAEWOO**

**DAEWOO ELECTRONICS CO., LTD.**

686, AHYEON-DONG MAPO-GU SEOUL, KOREA

C.P.O. BOX 8003 SEOUL, KOREA

TELEX: DWELEC K28177-8

CABLE: "DAEWOOELEC"

FAX: 82-2-360-7877

TEL: 82-2-360-7114

<http://www.dwe.co.kr>

PRINTED DATE: JULY.2000

S/M NO. : WF750SE001