

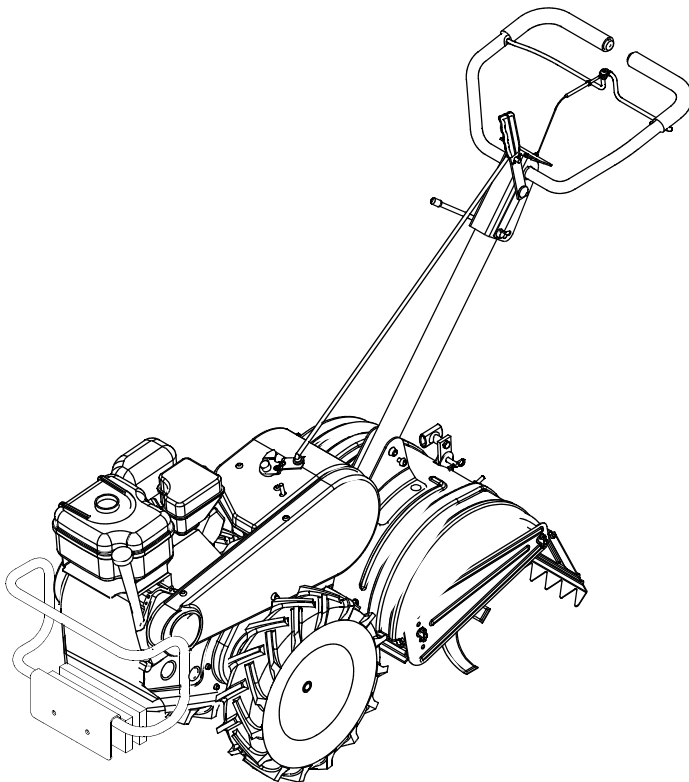

Operator's Manual



Rear Tine Tiller
Model 454

IMPORTANT: Read safety rules and instructions carefully before operating equipment.

Warning: This unit is equipped with an internal combustion engine and should not be used on or near any unimproved forest-covered, brush-covered or grass-covered land unless the engine's exhaust system is equipped with a spark arrester meeting applicable local or state laws (if any). If a spark arrester is used, it should be maintained in effective working order by the operator. In the State of California the above is required by law (Section 4442 of the California Public Resources Code). Other states may have similar laws. Federal laws apply on federal lands. A spark arrester for the muffler is available through your nearest engine authorized service dealer or contact the service department, P.O. Box 361131 Cleveland, Ohio 44136-0019.

CUB CADET LLC P.O. BOX 361131 CLEVELAND, OHIO 44136-0019

PRINTED IN U.S.A.

FORM NO. 770-10101E
(12/2003)

TABLE OF CONTENTS

Content	Page	Content	Page
Important Safe Operation Practices	3	Servicing Your Tiller	11
Loose Parts	5	Maintaining Your Tiller	11
Assembling Your Tiller	6	Off Season Storage	12
Know Your Tiller	8	Trouble Shooting Guide	13
Operating Your Tiller	9	Illustrated Parts	14
Making Adjustments	10	Warranty	20

FINDING MODEL NUMBER

This Operator's Manual is an important part of your new tiller. It will help you assemble, prepare and maintain the unit for best performance. Please read and understand what it says.



Before you start assembling your new equipment, please locate the model plate on the equipment and copy the information from it in the space provided below. A sample model plate is also given below. You can locate the model plate by standing at the operating position and looking down at the center of the rear tine cover. This information will be necessary to use the manufacturer's web site and/or to obtain help from the Customer Dealer Referral Line or an authorized service dealer.



Copy the model number here: _____

Copy the serial number here: _____

CUSTOMER SUPPORT

Please do NOT return the unit to the retailer from where it was purchased, without first contacting Customer Support.

If you have difficulty assembling this product or have any questions regarding the controls, operation or maintenance of this unit, you can seek help from the experts. Choose from the options below:

	<p>Visit cubcadet.com for many useful suggestions. Click on Customer Support button and you will get the three options reproduced here. Click on the appropriate button and help is immediately available.</p> <div style="text-align: center; margin: 20px 0;"> </div> <p style="text-align: center; color: gray; font-style: italic;">The answer you are looking for could be just a mouse click away!</p>	<p style="color: gray; font-style: italic;">The answer you are looking for could be just a mouse click away!</p>
	<p>To reach the Customer Dealer Referral Line, please call 1-877-282-8684.</p>	
	<p>The engine manufacturer is responsible for all engine-related issues with regards to performance, power-rating, specifications, warranty and service. Please refer to the engine manufacturer's Owner's/Operator's Manual, packed separately with your unit, for more information.</p>	

SECTION 1: IMPORTANT SAFE OPERATION PRACTICES



WARNING: This symbol points out important safety instructions which, if not followed, could endanger the personal safety and/or property of yourself and others. Read and follow all instructions in this manual before attempting to operate this machine. Failure to comply with these instructions may result in personal injury. When you see this symbol - **heed its warning**.

WARNING: Engine Exhaust, some of its constituents, and certain vehicle components contain or emit chemicals known to State of California to cause cancer and birth defects or other reproductive harm.

DANGER: This machine was built to be operated according to the rules for safe operation in this manual. As with any type of power equipment, carelessness or error on the part of the operator can result in serious injury. This machine is capable of amputating hands and feet and throwing objects. Failure to observe the following safety instructions could result in serious injury or death.

TRAINING

1. Read, understand, and follow all instructions on the machine and in the manual(s) before attempting to assemble and operate. Keep this manual in a safe place for future and regular reference and for ordering replacement parts.
2. Be familiar with all controls and their proper operation. Know how to stop the machine and disengage them quickly.
3. Never allow children under 14 years old to operate this machine. Children 14 years old and over should read and understand the operation instructions and safety rules in this manual and should be trained and supervised by a parent.
4. Never allow adults to operate this machine without proper instruction.
5. Keep bystanders, helpers, pets, and children at least 75 feet from the machine while it is in operation. Stop machine if anyone enters the area.

PREPARATION

1. Thoroughly inspect the area where the equipment is to be used. Remove all stones, sticks, wire, and other foreign objects which could be tripped over and cause personal injury.
2. Wear sturdy, rough-soled work shoes and close-fitting slacks and shirts. Loose fitting clothes or jewelry can be caught in movable parts. Never operate this machine in bare feet or sandals.
3. Disengage clutch levers and shift (if provided) into neutral (N) before starting the engine.
4. Never leave this machine unattended with the engine running.
5. Never attempt to make any adjustments while engine is running, except where specifically recommended in the operator's manual.
6. To avoid personal injury or property damage use extreme care in handling gasoline. Gasoline is extremely flammable and the vapors are explosive.

Serious personal injury can occur when gasoline is spilled on yourself or your clothes which can ignite. Wash your skin and change clothes immediately.

- a. Use only an approved gasoline container.
- b. Extinguish all cigarettes, cigars, pipes, and other sources of ignition.
- c. Never fuel machine indoors.
- d. Never remove gas cap or add while the engine is hot or running.
- e. Allow engine to cool at least two minutes before refueling.
- f. Never over fill fuel tank. Fill tank to no more than 1/2 inch below bottom of filler neck to provide space for fuel expansion.
- g. Replace gasoline cap and tighten securely.
- h. If gasoline is spilled, wipe it off the engine and equipment. Move machine to another area. Wait 5 minutes before starting the engine.
- i. Never store the machine or fuel container inside where there is an open flame, spark, or pilot light (e.g. furnace, water heater, space heater, clothes dryer, etc.)
- j. To reduce a fire hazard, keep machine free of grass, leaves, or other debris build-up. Clean up oil fuel spillage and remove any fuel soaked debris.
- k. Allow machine to cool at least 5 minutes before storing.

OPERATION

1. Do not put hands and feet near rotating parts. Contact with the rotating parts can amputate fingers, hands, and feet.
2. Do not operate machine while under the influence of alcohol or drugs.
3. Never operate this machine without good visibility or light. Always be sure of your footing and keep a firm hold on the handles.

4. Keep bystanders, helpers, pets, and children at least 75 feet from the machine while it is in operation. Stop the machine if anyone enters the area.
5. Be careful when tilling in hard ground. The tines may catch in the ground and propel the tiller forward. If this occurs, let go of the handlebars and do not restrain the machine.
6. Exercise extreme caution when operating on or crossing gravel surfaces. Stay alert for hidden hazards or traffic. Do not carry passengers.
7. Never operate the machine at high transport speeds on hard or slippery surfaces.
8. Exercise caution to avoid slipping or falling.
9. Look down, behind, and use care when in reverse or pulling machine towards you.
10. Start the engine according to the instructions found in this manual and keep feet well away from the tines at all times.
11. After striking a foreign object, stop the engine, disconnect the spark plug wire and ground against the engine. Thoroughly inspect the machine for any damage. Repair the damage before starting and operating.
12. Disengage all clutch levers and stop engine before you leave the operating position (behind the handles). Wait until the tines come to a complete stop before unclogging the tines, making any adjustments, or inspections.
13. Never run an engine indoors or in a poorly ventilated area. Engine exhaust contains carbon monoxide, an odorless and deadly gas.
14. Muffler and engine become hot and can cause a burn. Do not touch.
15. Use caution when tilling near fences, buildings and underground utilities. Rotating tines can cause property damage or personal injury.
16. Do not overload machine capacity by attempting to till soil to deep at to fast of a rate.
17. If the machine should start making an unusual noise or vibration, stop the engine, disconnect the spark plug wire and ground it against the engine.

Inspect thoroughly for damage. Repair any damage before starting and operating.

18. Keep all shields, guards and safety devices in place and operating properly.
19. Never pick up or carry machine while the engine is running.
20. Use only attachments and accessories approved by the manufacturer. Failure to do so, can result in personal injury.
21. If situations occur which are not covered in this manual, use care and good judgment. Contact your dealer for assistance. Telephone **1-877-282-8684** for the name of your nearest dealer.

Maintenance And Storage

1. Never tamper with safety devices. Check their proper operation regularly.
2. Check bolts and screws for proper tightness at frequent intervals to keep the machine in safe working condition. Also, visually inspect machine for any damage.
3. Before cleaning, repairing, or inspecting, stop the engine and make certain the tines and all moving parts have stopped. Disconnect the spark plug wire and ground it against the engine to prevent unintended starting.
4. Do not change the engine governor settings or over-speed the engine. The governor controls the maximum safe operating speed of the engine.
5. Maintain or replace safety and instruction labels, as necessary.
6. Follow this manual for safe loading, unloading, transporting, and storage of this machine.
7. Never store the machine or fuel container inside where there is an open flame, spark or pilot light such as a water heater, furnace, clothes dryer etc.
8. Always refer to the operator's manual for proper instructions on off-season storage.
9. If the fuel tank has to be drained, do this outdoors.
10. Observe proper disposal laws and regulations for gas, oil, etc. to protect the environment.



WARNING - YOUR RESPONSIBILITY: Restrict the use of this power machine to persons who read, understand and follow the warnings and instructions in this manual and on the machine.

NOTE: *Not all safety labels shown may apply to your tiller.*

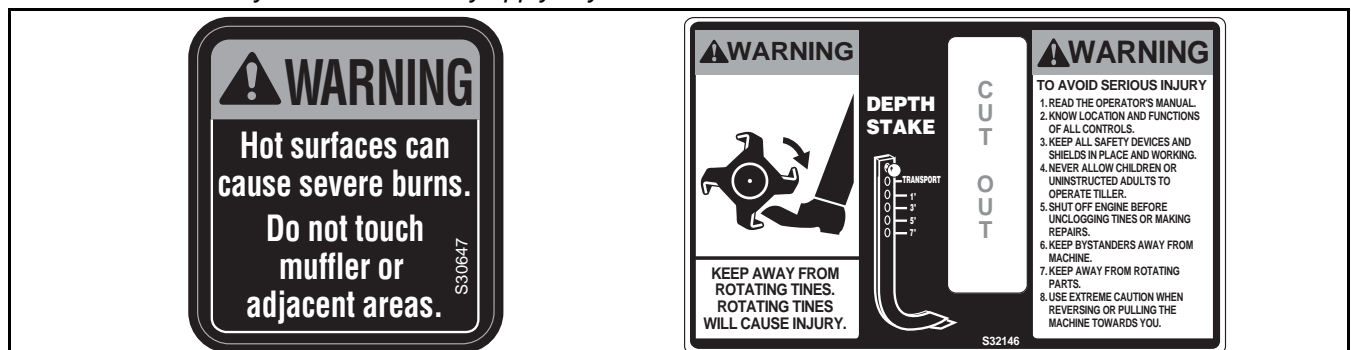

SECTION 2: LOOSE PARTS

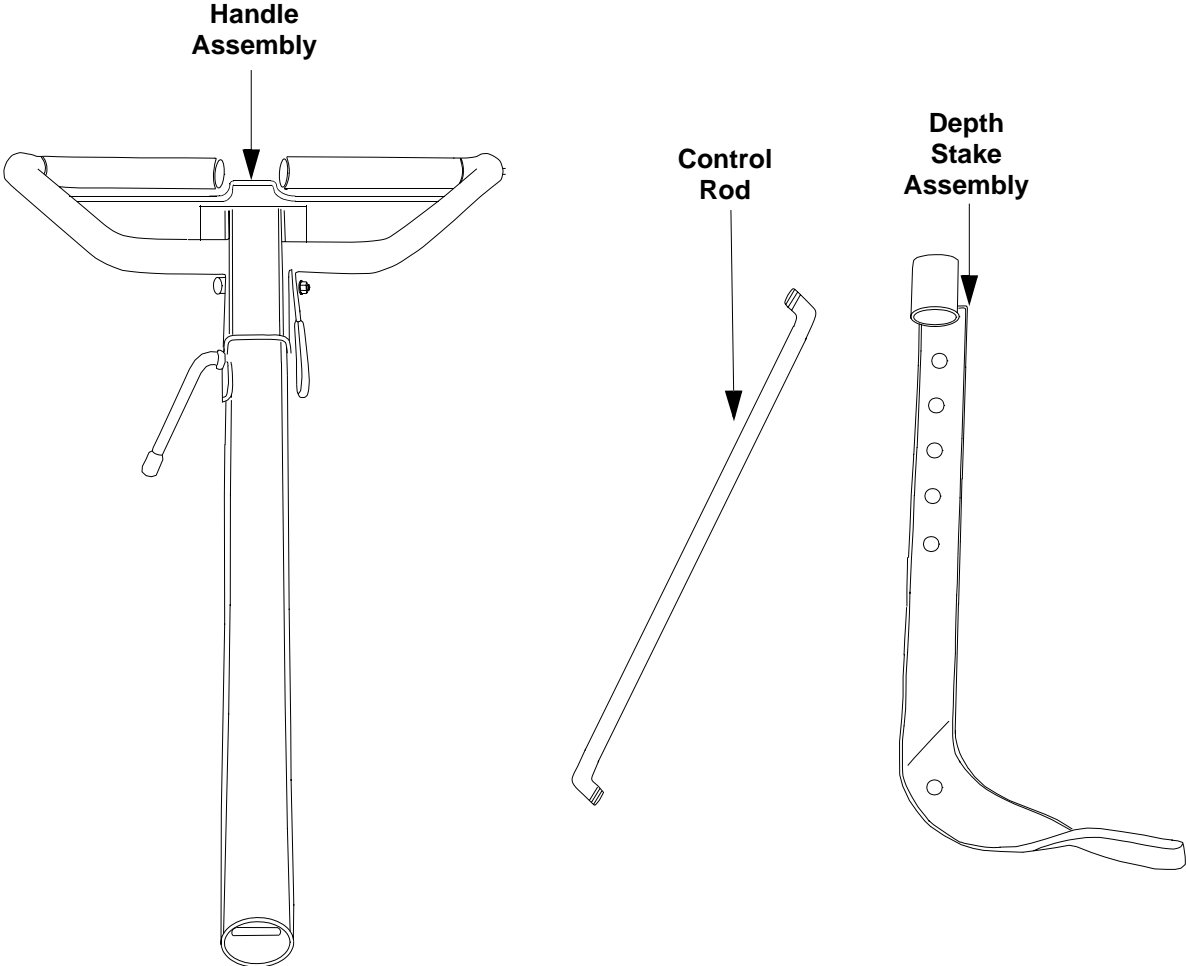

NOTE: *Cable tie not shown.*

SECTION 3: ASSEMBLING YOUR TILLER

IMPORTANT: This unit is shipped WITHOUT GASOLINE or OIL. After assembly, see separate engine manual for proper fuel and engine oil recommendations.

NOTE: Left and right is determined from the operator's position, standing behind the tiller.

Tools Required For Assembly

Adjustable Wrenches

Pair of Pliers

Screw Driver

To Remove Unit From Carton

- Remove staples, break glue on top flaps, or cut tape at carton end and peel along top flap to open carton.
- Remove loose parts included with unit (i.e., operator's manual, etc.).
- Cut corners and lay carton down flat.
- Remove packing material.
- Roll or slide unit out of carton. Check carton thoroughly for loose parts.
- Extend control cable and lay on the floor. Be careful not to bend or kink control cable.

Attaching Depth Stake Assembly

- Tip the tiller forward so it rests on front bumper.
- Raise the tine shield hinge flap assembly. Remove "T" knob, flat washer and hex bolt from depth stake. Insert the depth stake assembly in front of spacer (under the tine shield) and up through the tine shield assembly as shown in Figure 1.

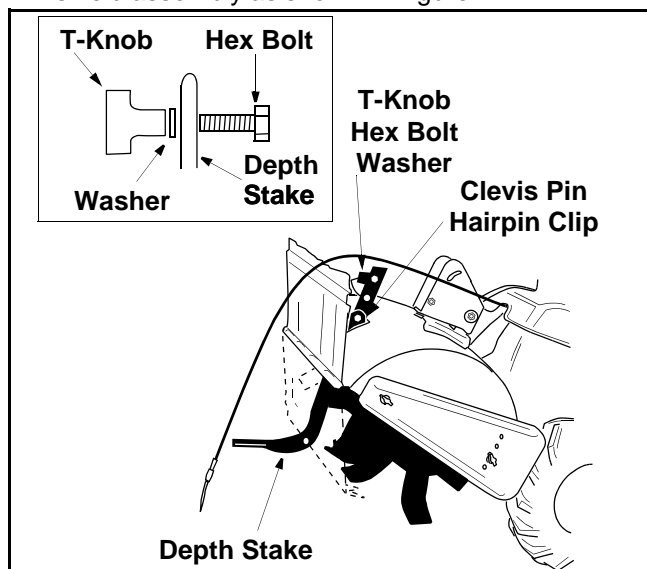

Figure 1

- Insert clevis pin through the tine shield and the second hole from top of the depth stake. Secure with hairpin clip.
- Insert hex bolt into the top hole of the depth stake assembly. Place flat washer on hex bolt and thread "T" knob onto the hex bolt. See Figure 1. Tighten securely.
- Tip the tiller back down so it rests on the depth stake (transport position).

Attaching The Handle Assembly

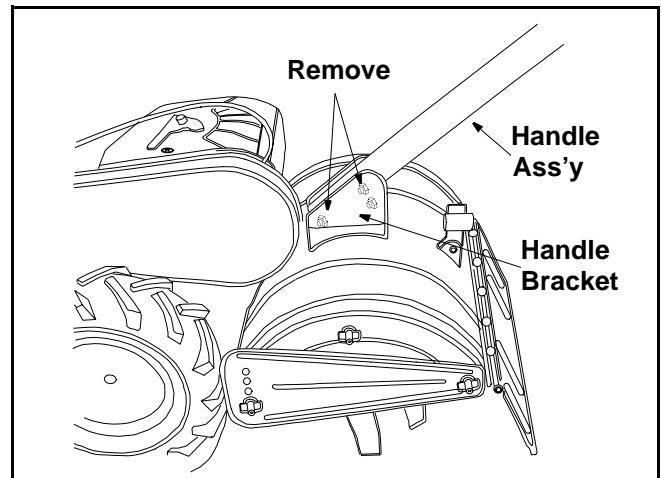

Figure 2

- Remove top two bolts and flange lock nuts from handle mounting brackets as shown in Figure 2. Do not remove the bottom bolt and nut.
- Place handle assembly in position between the handle mounting brackets. See Figure 2.
- Line up holes in handle with holes in handle mounting brackets. Secure with hardware removed in step 1.

Attaching The Clutch Cable

Attach the clutch cable to the handle as follows (be careful not to kink the cable).

- Remove threaded eyebolt and nut from the end of the cable.
- Route the clutch cable to the right side of the handle mounting brackets and underneath the handle.

- Push the cable through the hole in the center of the handle and snap in the plastic fitting. See Figure 3.

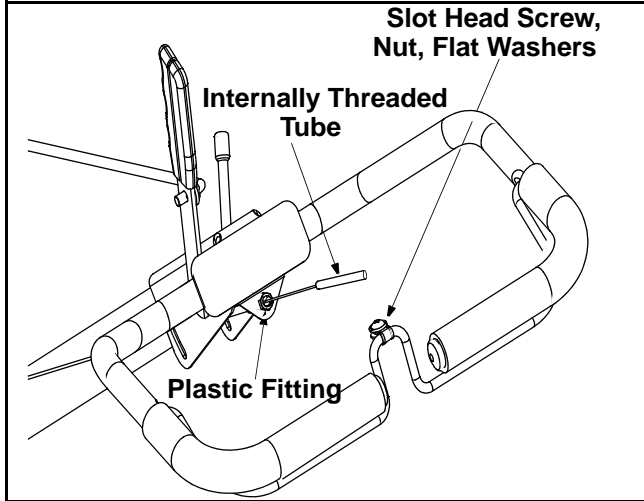

Figure 3

- Remove slot head screw, nut and two flat washers from the clutch bail.
- Fasten the threaded eyebolt onto bail as shown in Figure 4. The parts go together from top to bottom as follows: Slot Head Screw, Flat Washer, Clip, Eyebolt, Flat Washer and 1/4" Nut.
- Thread eyebolt and #10 nut, removed in step 1, into the internally threaded tube at the end of the cable. Thread engagement should be about 3/4". Tighten nut against tube at end of cable. See Figure 4.

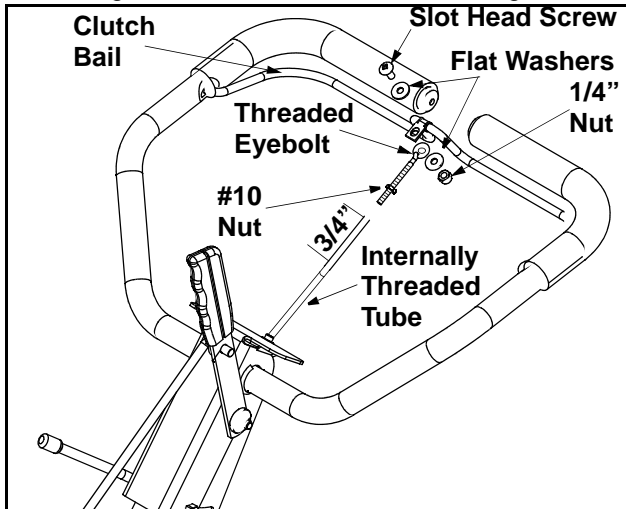

Figure 4

NOTE: Do not overtighten clutch cable. Too much tension may cause it to break.



WARNING: Be certain to check the clutch cable adjustment as instructed on this page before operating the tiller.

Secure clutch cable to handle using cable tie. Refer to Figure 6. Cut off excess end of cable tie.

Attaching The Control Rod

- Make sure the handle assembly is in the highest height position.
- Remove hairpin clips from control rod, (rubber washers to remain on control rod).
- Insert the shorter, (angled), end of the control rod through the indicator bracket on the shift cover and secure with hairpin clip that was removed in step 1. See Figure 5.
- Insert the longer end of the control rod through the hole in the gear selector handle and secure with hairpin clip. See Figure 6.

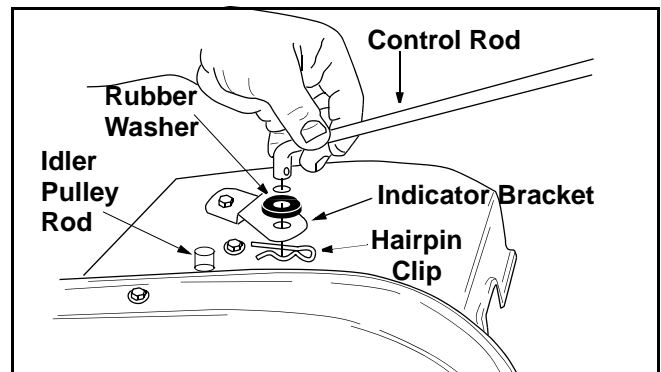

Figure 5

Checking The Clutch Adjustment

IMPORTANT: Service the engine with oil and gasoline before checking this adjustment. Refer to the separate engine manual packed with your tiller for proper fuel and engine oil recommendations.

Position the tiller so the front bumper is against a solid object, such as a wall. With the gear selection lever in NEUTRAL, start the engine. Refer to the separate engine manual.

Standing on the right side of the tiller, examine the belt (inside the belt cover). It should not be turning.

NOTE: Do not put fingers under the belt cover.

If the belt turns without bail engaged, adjust by unthreading the internally threaded tube at the end of the cable a few turns clockwise (when standing in operator's position), and then retighten the nut against the tube.

Now move the shift lever to FORWARD (Wheels Forward) position. Carefully engage the clutch by lifting the clutch control bail against the handle. The wheels should spin.

If the wheels do not spin with the unit in forward, adjust by unthreading the tube at the end of the cable a few turns counter-clockwise, (when standing in operator's position), and then retighten the nut against the tube.

Recheck both adjustments, and readjust as necessary.

NOTE: A secondary cable adjustment is available if you reach the point that additional adjustment is needed. Remove the belt cover and move the hex nuts at the other end of the cable towards the end of the casing. Then readjust the hex nuts at the handle.

Tire Pressure

The tires on your unit may be over-inflated for shipping purposes. Reduce the tire pressure before operating the unit. Recommended operating tire pressure is approximately 20 p.s.i. (check sidewall of tire for tire manufacturer's recommended pressure).



WARNING: Maximum tire pressure under any circumstances is 30 p.s.i. Equal tire pressure should be maintained on both tires.

SECTION 4: KNOW YOUR TILLER

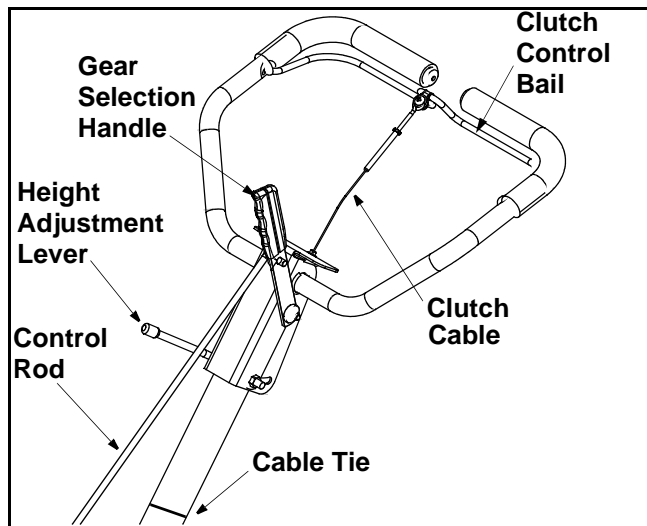

Figure 6

Throttle Control

The throttle control lever is located on the engine. It controls the engine speed and stops the engine. See Engine manual for further information.

Choke Lever

The choke lever is located to the left of the throttle. It is used to enrich the fuel mixture in the carburetor when starting a cold engine. See Engine manual for further information.

Gear Selection Handle

The gear selection handle is located in the center of the handle on the tiller. It is used to select NEUTRAL, REVERSE, or one of the FORWARD modes (see below). Pull or push the handle so that the indicator on top of shift cover points to the operating mode desired. See Figure 6.

NEUTRAL—Transmission is in neutral.

REVERSE—Reverse wheel drive.

FORWARD Modes:

Wheels Forward— Forward wheel drive only.

Tines Reverse— Forward wheel drive and reverse tine drive.

Tines Forward— Forward wheel and tine drive.



WARNING: Make certain unit is in NEUTRAL when starting the engine.

NOTE: If difficulty is encountered in moving the gear selection handle, move the tiller forward or backward slightly to allow the gears to synchronize.

Clutch Control Bail

The clutch control bail is located below the handle. See Figure 6. Lifting the clutch control bail against the handle engages the wheel and tine drive mechanisms.

NOTE: Never engage clutch lever while shifting.

Depth Stake

The depth bar controls the tilling depth. Refer to SECTION 5: OPERATING YOUR TILLER on page 9.

Handle Adjustment

The handle may be adjusted to be raised or lowered in line with the tiller. To adjust the handle position loosen the handle height adjustment crank a few turns. Pivot handle up or down to desired position. Tighten crank.

SECTION 5: OPERATING YOUR TILLER

NOTE: Engine is shipped without oil.



WARNING: Use the reverse tine drive when tilling virgin ground, sod or hard soil. Use the forward tine drive when cultivating or tilling soft ground.

Before Starting

- **Service engine with oil** as instructed in the separate engine manual packed with your unit.
- Fill fuel tank with clean, fresh, lead-free, low-lead or regular grade leaded gasoline.

To Start Engine



WARNING: Be sure no one is standing in front of the tiller while the engine is running or being started.

- Place the throttle control lever in the FAST (rabbit) position.
- Move choke lever to CHOKE position.

NOTE: A warm engine may not require choking.

- Stand at side of tiller. Grasp the starter handle with your right hand and pull out slowly, until it pulls slightly harder. Place your left hand on the lower portion of the upper handle.
- Pull starter handle rapidly. Do not allow handle to snap back. Allow it to rewind slowly while keeping a firm hold on the starter handle.
- Repeat steps 3 and 4 until engine starts.
- As engine warms up and begins to operate evenly, move choke lever gradually to RUN position. If engine falters, return to choke position, then slowly move to RUN position.
- Refer to engine manual for additional engine information.

NOTE: After starting engine and prior to using the tiller, be certain to check the clutch adjustment as described in "Checking the Clutch Adjustment" section of Assembly Instructions.

To Stop Engine

- Move throttle control to the STOP position.
- Disconnect spark plug wire and ground to prevent accidentally starting while equipment is unattended.

NOTE: After the first ten hours of operation, recheck the clutch adjustment. Refer to "Checking the Clutch Adjustment" section of the Assembly Instructions.



WARNING: When operating the tiller for the first time, use the depth stake setting that gives 1 inch of tilling depth (second hole from the top). See Figure 7.

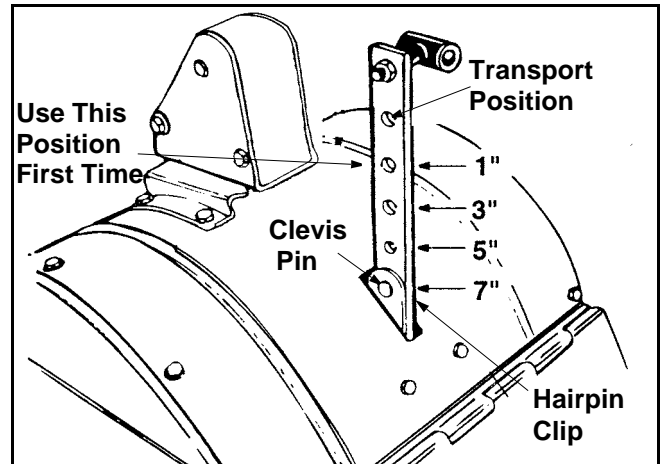

Figure 7

Tilling depth is controlled by the depth stake which can be adjusted to five different settings. See Figure 7. Adjust the side shields as shown in Figure 8, as you adjust the depth stake. Be certain spark plug wire is disconnected and grounded against the engine.

- To adjust the depth stake, remove the clevis pin and hairpin clip. See Figure 7. Move the depth stake to the desired setting.
- To adjust the side shields, remove the front wing nut and loosen the rear wing nut. Place side shield in position desired. Replace wing nuts and tighten securely. See Figure 8.

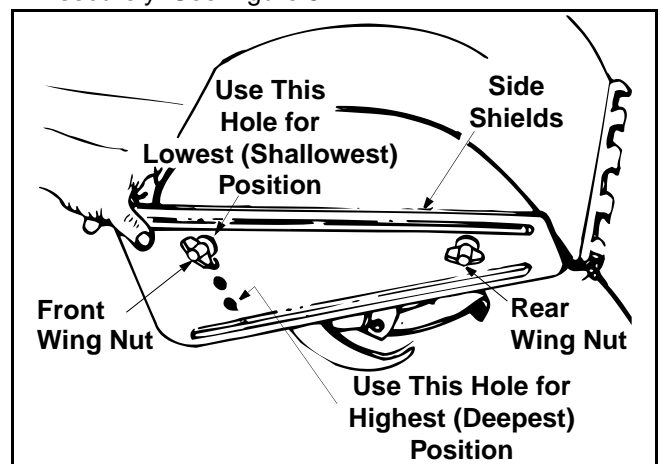

Figure 8

- When using the tiller for the first time, use the second adjustment hole from the top (1" of tilling depth). See Figure 7.

- When breaking up sod and for shallow cultivation, use the setting which gives 1" of tilling depth (second hole from the top). Place the side shields in their lowest position. For further depth, raise the depth stake and side shields and make one or two more passes over the area.
- When tilling loose soil, depth stake may be raised to its highest position (use bottom adjustment hole) to give the deepest tilling depth. Raise the side shields to their highest position.
- To transport tiller, lower the depth stake (use top adjustment hole).

To Operate The Tiller:

- Select the depth stake setting.
- Start engine as instructed on page 9.
- Move gear selection handle to one of the forward modes or reverse.

Use the reverse tine drive when tilling virgin ground, sod or hard soil. Use the forward tine drive when cultivating or tilling soft ground.

IMPORTANT: When using the forward tine drive, lower the depth stake (use a shallower tilling depth) to make certain the tines do not run across the ground.



WARNING: Do not move the gear selection handle with the wheels or tines engaged. Make certain the unit is stopped completely before changing the gear selection.

- Squeeze the clutch control bail against the handle to engage the wheels and tines.

NOTE: Make certain the gear selection indicator is correctly positioned before engaging the clutch handle. If it is between gears, the engine will stall.

To transport tiller, **do not** engage the tines. Select the wheel drive only.



WARNING: Do not push down on the handles so that the wheels are lifted off the ground while using the reverse tine drive, or the tiller could move backward and cause personal injury.

For best results, it is recommended the garden be tilled twice (lengthwise, then widthwise) to pulverize the soil.

SECTION 6: MAKING ADJUSTMENTS

Handle Adjustment

The handle height may be adjusted. Refer to the Know Your Tiller section for details of handle adjustment.

Belt Tension Adjustment

Periodic adjustment of the belt tension may be required due to normal stretch and wear on the belt. Adjustment is needed if the tines or wheels seem to hesitate while turning, but the engine maintains the same speed.

To adjust the tension on the belt, refer to clutch adjustment information in "Checking the Clutch Adjustment" section of the Assembly Instructions. After belt tension has been adjusted, if the belt is excessively stretched, you may need to adjust the idler pulley rod. This can easily be checked. With the engine off and the clutch control bail disengaged, shift the gear selection handle to each forward mode. If the indicator bracket touches the idler pulley rod, (with the clutch control bail disengaged), then an adjustment is necessary.

- Disconnect and ground out spark plug wire against the engine.

- Remove the belt cover as described in the belt replacement section on page 11.
- Remove the hairpin clip and spring washer from the idler pulley rod. See Figure 10.
- Move the idler pulley rod to the lower hole in the idler bracket. See Figure 10.
- Replace the spring washer and hairpin clip.
- Check clearance of the idler pulley rod to the indicator bracket by shifting to each forward mode, as before.

Carburetor Adjustment



WARNING: If any adjustments are made to the engine while the engine is running, (e.g. carburetor), disengage all clutches and tines. Keep clear of all moving parts. Be careful of heated surfaces and muffler.

Never make unnecessary adjustments. The factory settings are correct for most applications. If adjustments are needed, refer to the separate engine manual packed with your tiller.

SECTION 7: SERVICING YOUR TILLER

Transmission—The transmission is pre-lubricated and sealed at the factory. It requires no checking unless the transmission is disassembled. To fill with grease, lay the right half of the transmission on its side. Add 30 ounces of Benalene 920 grease. Apply a bead of RTV or silicone sealant to the right half of the transmission, all the way around the gear compartment. Assemble the left half to it. This grease can be obtained at your nearest authorized dealer. Order part number 737-0300.

Clutch Bail—Lubricate the pivot point on the clutch bail and the cable at least once a season with light oil. The control must operate freely in both directions.

Pivot Points—Lubricate all pivot points and linkages at least once a season with light oil.

Tine Shaft—Remove tines at least once a season and lubricate with oil.

Wheel Axle—Remove the wheel assemblies at least once a season and lubricate with oil.

SECTION 8: MAINTAINING YOUR TILLER



WARNING: Disconnect the spark plug wire and ground it against the engine before performing any repairs or maintenance.

Engine

Refer to the separate engine manual for engine maintenance instructions.

Your engine is equipped with a oil drain pipe and cap located on the bottom right side of the engine which will help in draining the oil from the engine. Always drain oil when it is warm. To drain oil, remove cap and drain oil into a suitable container. Dispose of oil properly.

Maintain **engine oil** as instructed in the separate engine manual packed with your unit. Read and follow instructions carefully.

Service **air cleaner** every ten hours under normal conditions. Clean every hour under extremely dusty conditions. Poor engine performance and flooding usually indicates that the air cleaner should be serviced. To service the air cleaner, refer to the separate engine manual packed with your unit.

IMPORTANT: Never run your engine without air cleaner completely assembled.

The **spark plug** should be cleaned and the gap reset every 25 hours of engine operation. Spark plug replacement is recommended at the start of each tiller season; check engine manual for correct plug type and gap specification.

Clean the engine regularly with a cloth or brush. Keep the cooling system (blower housing area) clean to permit proper air circulation which is essential to engine performance and life. Be certain to remove all dirt and combustible debris from muffler area.

Cleaning The Tine Area

Clean the underside of the tine shield after each use. The dirt washes off the tines easier if washed off immediately instead of after it dries.

We do not recommend the use of pressure washers to clean your unit. They may cause damage to pulleys, bearings, or the engine. The use of pressure washers will result in shortened life and reduce serviceability.

Belt Replacement



CAUTION: Do not use an off-the-shelf belt.

Your tiller has been engineered with a belt made of special material (Kevlar Tensile) for longer life and better performance. It should not be replaced with an off-the-shelf belt.

If belt replacement is required, order belt by part number from your nearest authorized dealer.

Part No. 754-0434—"V" Belt

- Disconnect and ground the spark plug wire against the engine.

Remove the belt cover from the left side of the tiller as follows:

- Remove two torx screws from the top of belt cover. See Figure 9.
- Remove the hex cap nut and flat washer from the side of the belt cover. Remove the self-tap screw at the bottom of the front of the cover.
- Remove the belt keeper bracket located behind the engine pulley by removing two hex bolts and lock washers. See Figure 10.
- Remove belt. Reassemble new belt, following instructions in reverse order.

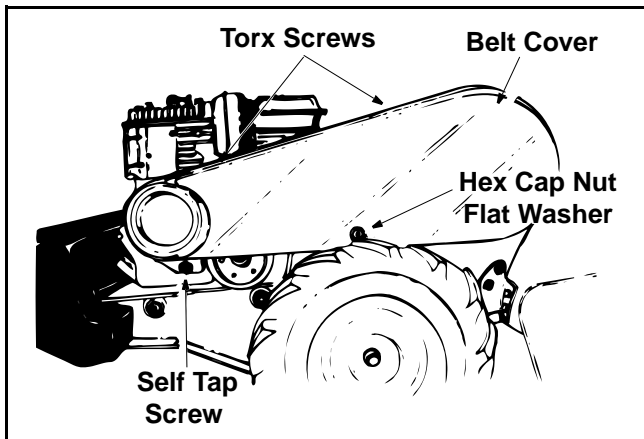

Figure 9

Upon reassembly, make certain the belt is routed over the idler pulley and inside of belt keepers by engine pulley. See Figure 10.

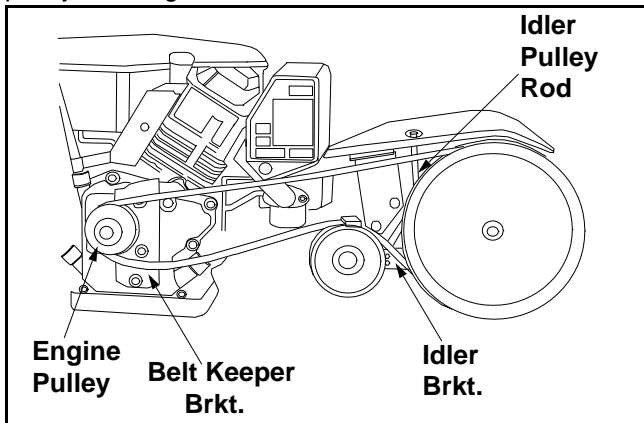

Figure 10

Tires

Recommended operating tire pressure is approximately 20 p.s.i. (check sidewall of tire for tire manufacturer's recommended pressure). Maximum tire pressure under any circumstances is 30 p.s.i. Equal tire pressure should be maintained on both tires.

When installing a tire to the rim, be certain rim is clean and free of rust. Lubricate both the tire and rim generously. Never inflate to over 30 p.s.i. to seat beads.



WARNING: Excessive pressure (over 30 p.s.i.) when seating beads may cause tire/rim assembly to burst with force sufficient to cause serious injury.

SECTION 9: OFF-SEASON STORAGE

If the tiller will not be used for a period longer than 30 days, the following steps should be taken to prepare the tiller for storage.

- Clean the exterior of engine and the entire tiller thoroughly. Lubricate the tiller as described in the lubrication instructions.
- We do not recommend the use of pressure washers to clean your unit. They may cause damage to pulleys, bearings or the engine. The use of pressure washers will result in shortened life and reduce serviceability.
- Refer to the engine manual for correct engine storage instructions.

- Wipe tines with oiled rag to prevent rust.
- Store tiller in a clean, dry area. Do not store next to corrosive materials, such as fertilizer.

NOTE: When storing any type of power equipment in an unventilated or metal storage shed, care should be taken to rustproof the equipment. Using a light oil or silicone, coat the equipment, especially any springs, bearings and cables.

SECTION 10: TROUBLE SHOOTING GUIDE

Trouble	Possible Cause(s)	Corrective Action
Engine fails to start	Fuel tank empty, or stale fuel. Throttle control lever not in correct starting position (if so equipped). Blocked fuel line. Dirty aircleaner. Choke not in ON position. Spark plug wire disconnected. Faulty spark plug. Engine flooded.	Fill tank with clean, fresh gasoline. Fuel will not last over thirty days unless a fuel stabilizer is used. Move throttle lever to start position. Clean fuel line. Refer to the engine manual packed with your unit. Move choke lever to ON position. Connect wire to spark plug. Clean, adjust gap or replace. Refer to the engine manual packed with your unit.
Engine runs erratic	Unit running on CHOKE. Spark plug wire loose. Blocked fuel line or stale fuel. Vent in gas cap plugged. Water or dirt in fuel system. Dirty air cleaner. Carburetor out of adjustment.	Move choke lever to OFF position. Connect and tighten spark plug wire. Clean fuel line; fill tank with clean, fresh gasoline. Fuel will not last over thirty days unless a fuel stabilizer is used. Clear vent. Drain fuel tank. Refill with fresh fuel. Refer to the engine manual packed with your unit. Refer to the engine manual packed with your unit.
Engine overheats	Engine oil level low. Dirty air cleaner. Air flow restricted. Carburetor not adjusted properly.	Fill crankcase with proper oil. Refer to the engine manual packed with your unit. Refer to the engine manual packed with your unit. Adjust carburetor as instructed in separate engine manual.
Tines do not engage	Foreign object lodged in tines. Tine clevis pin(s) missing. Pulley and idler not in correct adjustment. Not shifting properly. Control cable not adjusted properly. Belt worn and/or stretched.	Dislodge foreign object. Replace tine clevis pin(s). Take unit to authorized service dealer. Refer to Controls section of operator's manual for proper shifting procedures. Adjust control cable (see assembly instructions). Replace belt.
Tines skip over ground	Improper rotation.	Forward rotation should only be used on soil that has already been tilled, not on virgin soil.
Wheels do not engage	Clevis pin missing. Tiller is not being shifted properly. Control cable not adjusted properly. Belt worn and/or stretched.	Replace clevis pin. Refer to Controls section of operator's manual for proper shifting procedures. Adjust control cable (see assembly instructions). Replace belt.

NOTE: For repairs beyond the minor adjustments above, contact your local authorized service dealer.

SECTION 11: PARTS LIST FOR MODEL 454

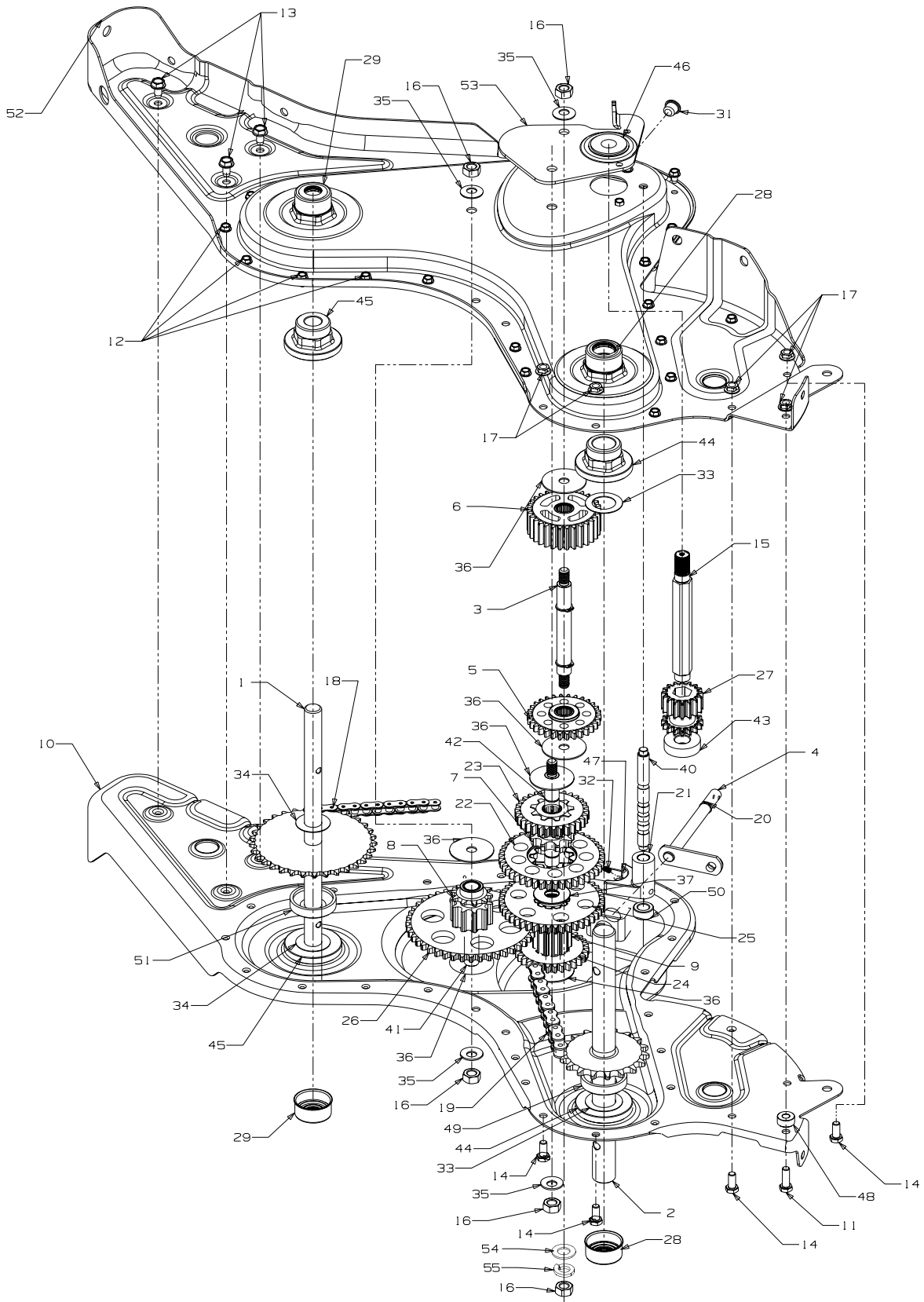

Model 454

REF. NO.	PART NO.	DESCRIPTION	REF. NO.	PART NO.	DESCRIPTION
1	611-0020	Wheel Shaft Ass'y: 33T	29	721-0379	Seal.75 Shaft
2	611-0021	Tine Shaft Ass'y: 18T	31	726-0277	Taper Cap Ring
3	611-0128	Jack Shaft Ass'y	32	732-0496	Compression Spring.50" Lg.
4	611-0129	Input Shaft Ass'y	33	736-0163	Thrust Wash. 1.03" I.D. x 1.62"
5	617-0058	Rev. Idler Gear Ass'y: 30T	34	736-0351	Fl-Wash.76" I.D. X. 1.5" O.D.
6	617-0059	Ftine Idler Gear Ass'y: 30T	35	736-0407	Bell-Wash.45" I.D. X. 1.0"
7	617-0060	Tine Input Sprocket Ass'y: 9T	36	736-0518	Thrust Wash.445 x 1.92 x.060
8	617-0061	Wheel Input Sprocket Ass'y: 10T	37	736-3088	Fl-Wash.635" I.D. x 1.59 O.D.
9	617-0062	Gear Ass'y: 11T	40	738-0645	Detent Shaft 1/2" Dia.
10	686-0108	R.H. Housing Ass'y	41	738-0648	Jack Shaft.625 x 2.385
11	710-0376	Hex Bolt 5/16-18 x 1" Lg.	42	738-1013	Jack Shaft.625 x 5.0
12	710-0599	Hex S-Tap Scr. 1/4- 20 x.5"	43	741-0124	Ball Bearing
13	710-0604A	Hex S-Tap Scr. 5/16-18 x.625"	44	741-0420	Flange Bearing 1.0 x 2.5 x 1.38
14	710-3008	Hex Bolt 5/16-18 x.75"	45	741-0421	Flange Bearing.75 x 2.5 x 1.38
15	711-1349	Input Shaft	46	741-0563	Ball Bearing. 6692 x 5745 x.466
16	712-0378	Hex Nut 7/16-20	47	741-0862	Detent Ball.250
17	712-3004A	Flange Nut 5/16-18	48	750-0258	Spacer.315
18	713-0367	#420 Chain 1/2 Pitch x 50 Links	49	750-0570	Spacer 1.0 I.D x 2.0 O.D. x.440
19	713-0484	#50 Chain 5/8 Pitch x 54 Links	50	750-0664	Spacer.505 I.D. x.88 O.D. x.440
20	716-0865	Snap Ring	51	750-0671	Spacer.75 x 2.0 x.50
21	717-0853	Shifting Fork	52	786-0171	L.H. Chain Case Ass'y
22	717-1582	Spur Gear 44T	53	786-0238	Gear Positioner Bracket
23	717-1583	Spur Gear 30T	54	736-0226	Flat Washer,.474ID x.879OD
24	717-1584	Spur Gear 30T	55	736-0171	Lock Washer, 7/16
25	717-1585	Spur Gear 44T	-	737-0300	Benelene 920 Grease
26	717-1587	Spur Gear 44T	-	737-0288	Never Seez Grease
27	717-1594	Spur Gear 16T	-	686-0107	Gear Case Assembly Complete
28	721-0378	Seal 1.0 Shaft			

NOTE: For **paint**ed parts, please refer to the list of color codes below. Please add the applicable color code, wherever needed, to the part number to order a replacement part. For instance, if a part, numbered 700-xxxx, is painted Cub Yellow, the part number to order would be 700-xxxx-0716.

Cub Yellow: 0716
 Cub Beige: 0499
 Powder Black: 0637

Model 454

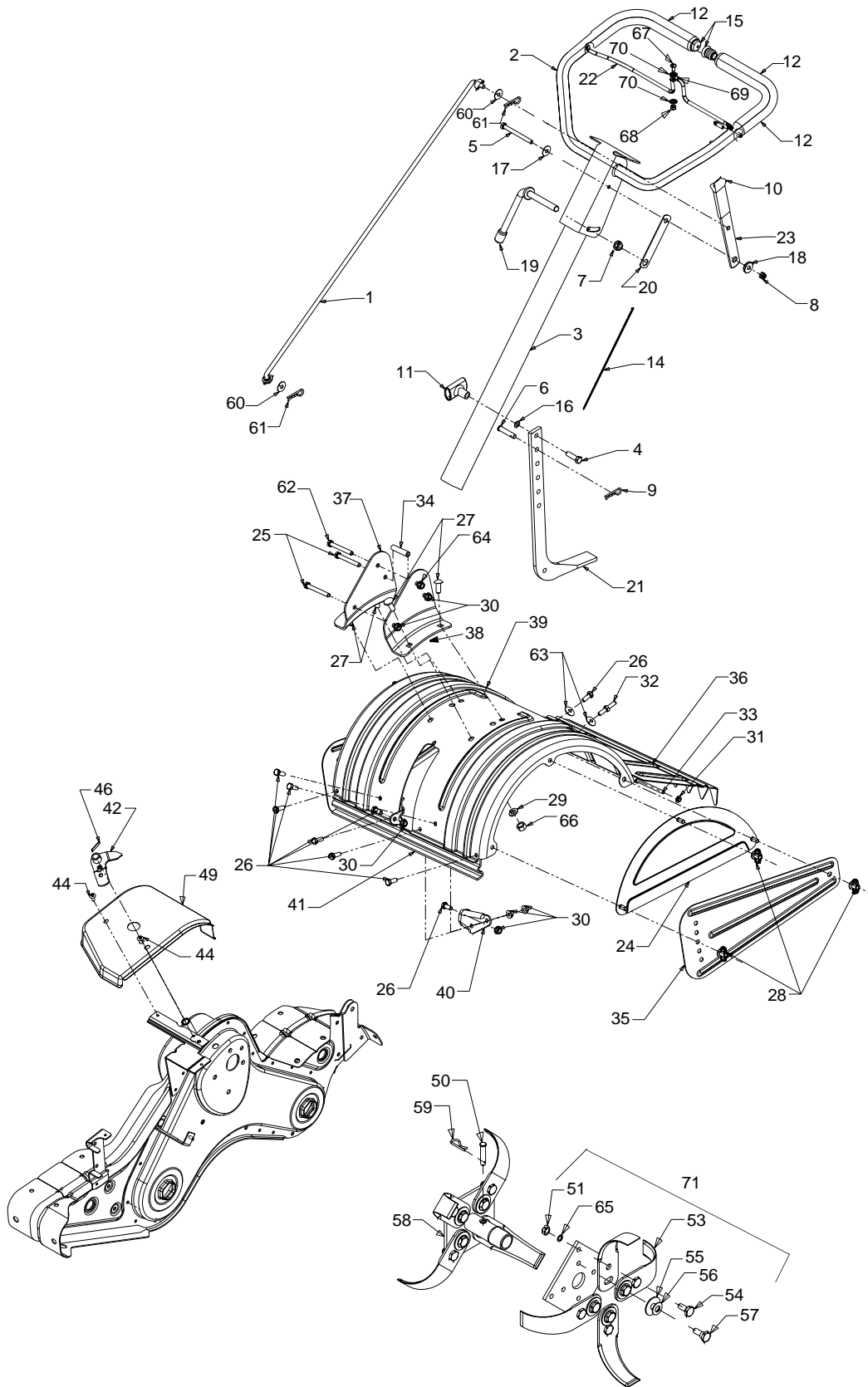

Model 454

REF. NO.	PART NO.	DESCRIPTION	REF. NO.	PART NO.	DESCRIPTION
1	747-1152	Shift Rod	35	786-0090	Side Shield
2	649-0041	Upper Handle Ass'y	36	786-0113	Tine Shield Hinge Flap
3	649-0034	Lower Handle Ass'y	37	786-0176	R.H. Handle Brkt.
4	710-3005	Hex Screw 3/8-16 x 1.25	38	786-0177	L.H. Handle Brkt.
5	710-3056	Hex Screw 5/16-18 x 3.25	39	786-0178	Tine Shield
6	711-0415	Clevis Pin 3/8-1.62	40	786-0179	Tine Shield Brkt.
7	712-0379	Flange Lock Nut 3/8-24	41	786-0180	Tine Shield Scraper Bracket
8	712-0429	Hex Lock Nut 5/16-18	42	686-0109	Shift Crank Ass'y
9	714-0147	Cotter Pin	44	710-1017	Screw 1/4-14 x.625
10	720-0313	Grip	46	715-0120	Spirol Pin 3/16 x 1.00
11	720-0210A	T-Knob	49	784-0208C	Shift Cover
12	720-0278A	Foam Grip	50	711-0415	Clevis Pin
14	726-0317	Cable Tie	51	712-3054	Hex Nut 3/8-24 Thd.
15	735-0246	Plug	53	742-0305	13" Dia. Articulating Tine
16	736-0117	Flat Washer 3/8 x.620 x.033	54	738-0689	Shld. Bolt 1/2" Dia. x.175
17	736-0242	Bell Wash.340 I.D. x.872 O.D.	55	736-0208	Fl-Wash.51" I.D. x 1.50"
18	738-0958	Shoulder Spacer	56	736-0253	Bell-Wash.515" I.D. x 1.14"
19	784-0190	Handle Adjustment Crank	57	738-0688	Shld. Bolt 1/2" Dia x.320
20	784-0191	Hex Nut Ret. Bracket	58	784-0160	Tine Adapter Ass'y 18"
21	786-0120	Depth Stake	59	714-0149B	Internal Cotter Pin
22	747-1219	Bail Clutch	60	735-0127	Rubber Washer
23	786-0181	Shift Lever Rod	61	714-0104	Cotter Pin
24	686-0044A	Tine Shield Cover Ass'y	62	710-3022	Hex Screw 3/8-16 x 2.75" Lg.
25	710-0176	Hex Cap Screw 5/16-18 x 2.75	63	736-0204	Flat Washer
26	710-3008	Hex Cap Screw 5/16-18 x.750	64	712-0431	Flange Nut.344 I.D. x.62 O.D.
27	710-3097	Carriage Bolt 3/8-16 x 1.0	65	736-0169	Lock Washer
28	712-0421	Wing Nut	66	712-0798	Hex Nut 3/8-16
29	736-0169	Lock Washer 3/8	67	710-0946	Truss Screw 1/4-20 x.65
30	712-3004A	Flange Nut 5/16-18	68	712-0324	Hex Lock Nut 1/4-20 Gr. 8
31	726-0106	Cap Nut	69	726-0273	Battery Hose Clamp 5/16
32	738-0849	Hex Screw 5/16-18 x.75" Lg.	70	736-3090	Flat Washer.260 x.720 x.060
33	747-0432	Tiller Flap Rod	71	784-0205	Tine Ass'y Complete
34	750-0885A	Spacer.435 O.D. x.322 I.D.			

Labels

Ref. No.	Part No.	Code	Description
N/I	777S30647		Hot Surfaces
N/I	777S32146		Tine Shield Warning
N/I	777I22260		Shaft Drive 454
N/I	777I20358		Place Hand Here on Handle
N/I	777I20451		Gear Selection on Handle
N/I	777D08234		Belt Guard

Model 454

REF. NO.	PART NO.	DESCRIPTION	REF. NO.	PART NO.	DESCRIPTION
1	686-0111	Belt Cover Brkt. Ass'y	26	786-0186	Belt Keeper Brkt.
2	710-0237	Hex Bolt 5/16-24 x.62" Lg.	27	786-0187	Shift Cover Brkt.
3	710-0412	Hex Bolt 1/4-28 x.75" Lg.	28	786-0193	Idler Belt Keeper
4	710-0502A	Hex Wash.TT-Sems Screw 3/8-16 x 1.250" Lg.	29	634-0234	RH Wheel Ass'y Comp. 16.0 x 4.0
5	710-0152	Hex Bolt 3/8-24 x 1.00		634-0235	LH Wheel Ass'y Comp. 16.0 x 4.0
6	710-0599	Hex Wash. Hd. S-Tap Scr.	30	734-0808	Tire Only 16.0 x 4.0
7	710-0723	Hex Cap Screw 3/8-16 x 1.25	31	634-0108	Wheel Rim Ass'y Comp.
8	712-0266	Ctr. Lock Jam Nut 3/8-16	32	734-0255	Air Valve
9	712-0267	Hex Nut 5/16-18	33	711-1017	Clevis Pin
10	714-0104	Internal Cotter Pin	34	714-0104	Internal Cotter Pin
11	736-0104	Hairpin Clip	35	710-0515	Hex Hd. Cap Screw 1/2-20 x 3.50 Gr. 5
12	736-0119	L-Wash. 5/16" I.D.	36	712-0333	Hex Nut 1/2-20 Thd. Gr. 2
13	736-0176	FI-Wash. 1/4 I.D. x.93 O.D.	37	786-0343	Counterweight
14	736-0271	Spring-Wash.317 x.625 O.D. x.099	38	736-0326	FI-Wash.510" I.D. x 1.0" O.D.
15	736-0329	L-Wash. 1/4" I.D.	39	736-0921	L-Wash. 1/2" Lg.
16	736-0452	Bell-Wash.396 x 1.140 x.095	40	710-0653	Hex Screw 1/4-20 x.375" Lg.
17	738-0876	Shld. Nut 7/16-20	41	710-1017	Screw 1/4-14 x.625" Lg.
18	746-1117	Clutch Cable	42	712-0392	Acorn Lock Nut
19	747-1159	Idler Pulley Rod	43	736-3020	FI-Washer.271 x.630 x.065
20	754-0434	Belt: 4L x 58.16 Lg.	44	784-0158A	Belt Cover
21	756-0405	FI-Idler w/Flange 3.75" O.D.	45	710-0805	Hex Bolt 5/16-18 x 1.50" Lg.
22	756-0971	Outer Engine Pulley Half	46	736-0242	Bell-Wash.340 I.D. x.872 O.D.
23	756-0972	Inner Engine Pulley Half	47	712-3010	Hex Nut 5/16-18
24	756-1162	Input Pulley		737-0298	Oil Drain Tube (Not Shown)
25	786-0064A	Idler Bracket		737-0132	End Cap (Not Shown)
				686-0192	Bumper Assembly

NOTE: For **Painted parts**, please refer to the list of color codes below. Please add the applicable color code, wherever needed, to the part number to order a replacement part. For instance, if a part, numbered 700-xxxx, is painted Cub Yellow, the part number to order would be 700-xxxx-0716.

Cub Yellow: 0716
Cub Beige: 0499
Powder Black: 0637

MANUFACTURER'S LIMITED WARRANTY FOR:



The limited warranty set forth below is given by Cub Cadet LLC with respect to new merchandise purchased and used in the United States, its possessions and territories.

"Cub Cadet" warrants this product against defects in material and workmanship for a period of two (2) years commencing on the date of original purchase and will, at its option, repair or replace, free of charge, any part found to be defective in materials or workmanship. This limited warranty shall only apply if this product has been operated and maintained in accordance with the Operator's Manual furnished with the product, and has not been subject to misuse, abuse, commercial use, neglect, accident, improper maintenance, alteration, vandalism, theft, fire, water, or damage because of other peril or natural disaster. Damage resulting from the installation or use of any part, accessory or attachment not approved by Cub Cadet for use with the product(s) covered by this manual will void your warranty as to any resulting damage.

Normal wear parts are warranted to be free from defects in material and workmanship for a period of thirty (30) days from the date of purchase. Normal wear parts include, but are not limited to items such as: batteries, belts, blades, blade adapters, grass bags, rider deck wheels, seats, snow thrower skid shoes, shave plates, auger spiral rubber and tires.

HOW TO OBTAIN SERVICE: Warranty service is available, WITH PROOF OF PURCHASE, through your local authorized service dealer. To locate the dealer in your area, check your Yellow Pages, or contact Cub Cadet LLC at P.O. Box 361131, Cleveland, Ohio 44136-0019, or call 1-877-282-8684, or log on to our Web site at www.cubcadet.com.

This limited warranty does not provide coverage in the following cases:

- a. The engine or component parts thereof. These items may carry a separate manufacturer's warranty. Refer to applicable manufacturer's warranty for terms and conditions.
- b. Log splitter pumps, valves, and cylinders have a separate one year warranty.
- c. Routine maintenance items such as lubricants, filters, blade sharpening, tune-ups, brake adjustments, clutch adjustments, deck adjustments, and normal deterioration of the exterior finish due to use or exposure.
- d. Cub Cadet does not extend any warranty for products sold or exported outside of the United States, its

possessions and territories, except those sold through Cub Cadet's authorized channels of export distribution.

- e. Replacement parts that are not genuine Cub Cadet parts.
- f. Service completed by someone other than an authorized service dealer.
- g. Transportation charges and service calls.

No implied warranty, including any implied warranty of merchantability of fitness for a particular purpose, applies after the applicable period of express written warranty above as to the parts as identified. No other express warranty, whether written or oral, except as mentioned above, given by any person or entity, including a dealer or retailer, with respect to any product, shall bind Cub Cadet. During the period of the warranty, the exclusive remedy is repair or replacement of the product as set forth above.

The provisions as set forth in this warranty provide the sole and exclusive remedy arising from the sale. Cub Cadet shall not be liable for incidental or consequential loss or damage including, without limitation, expenses incurred for substitute or replacement lawn care services or for rental expenses to temporarily replace a warranted product.

Some states do not allow the exclusion or limitation of incidental or consequential damages, or limitations on how long an implied warranty lasts, so the above exclusions or limitations may not apply to you.

In no event shall recovery of any kind be greater than the amount of the purchase price of the product sold. **Alteration of safety features of the product shall void this warranty.** You assume the risk and liability for loss, damage, or injury to you and your property and/or to others and their property arising out of the misuse or inability to use the product.

This limited warranty shall not extend to anyone other than the original purchaser or to the person for whom it was purchased as a gift.

HOW STATE LAW RELATES TO THIS WARRANTY: This limited warranty gives you specific legal rights, and you may also have other rights which vary from state to state.

IMPORTANT: Owner must present Original Proof of Purchase to obtain warranty coverage.

Cub Cadet LLC, P.O. BOX 361131 CLEVELAND, OHIO 44136-0019; Phone: 1-877-282-8684