

Cub Cadet

Power Equipment

Owner's Manual

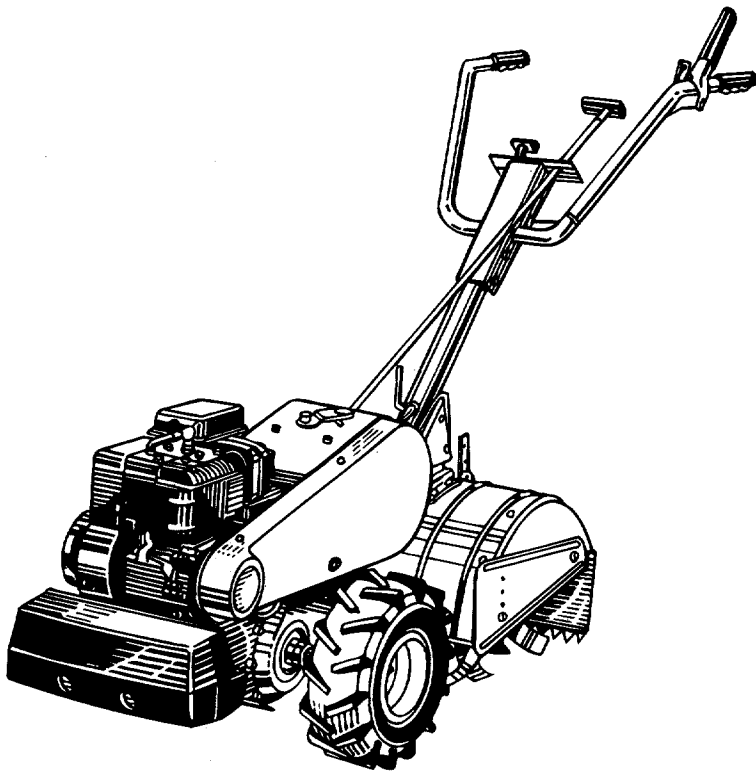

**5 H.P.
REAR TINE
TILLER**

**Model Number
440
(215-440-100)**

Important:
Read Safety Rules and Instructions Carefully
Thank you for purchasing an American-built product.

WARNING: This unit is equipped with an internal combustion engine and should not be used on or near any unimproved forest-covered, brush-covered or grass-covered land unless the engine's exhaust system is equipped with a spark arrester meeting applicable local or state laws (if any). If a spark arrester is used, it should be maintained in effective working order by the operator.

In the State of California the above is required by law (Section 4442 of the California Public Resources Code). Other states may have similar laws. Federal laws apply on federal lands. A spark arrester for the muffler is available through your nearest authorized service dealer.

CUB CADET CORPORATION • P.O. BOX 368023 • CLEVELAND, OHIO 44136-9723

INDEX

Rules for Safe Operation	2	Adjustments	10
Assembly	3	Lubrication	11
Controls	8	Maintenance	11
Operation	9	Off-Season Storage	12
How To Use Your Tiller.....	9	Trouble Shooting Guide.....	13

IMPORTANT

RULES FOR SAFE OPERATION



THIS SYMBOL POINTS OUT IMPORTANT SAFETY INSTRUCTIONS WHICH, IF NOT FOLLOWED, COULD ENDANGER THE PERSONAL SAFETY AND/OR PROPERTY OF YOURSELF AND OTHERS. READ AND FOLLOW ALL INSTRUCTIONS IN THIS MANUAL BEFORE ATTEMPTING TO OPERATE YOUR TILLER. FAILURE TO COMPLY WITH THESE INSTRUCTIONS MAY RESULT IN PERSONAL INJURY. WHEN YOU SEE THIS SYMBOL—  **HEED ITS WARNING.**



 **DANGER: Your tiller was built to be operated according to the rules for safe operation in this manual. As with any type of power equipment, carelessness or error on the part of the operator can result in serious injury. If you violate any of these rules, you may cause serious injury to yourself or others.**

1. It is suggested that this manual be read in its entirety before attempting to assemble or operate this unit. Keep this manual in a safe place for future and regular reference and for ordering replacement parts.
2. Your tiller is a precision piece of power equipment, not a plaything. Therefore, exercise extreme caution at all times.
3. Read this owner's manual carefully. Be thoroughly familiar with the controls and the proper use of the equipment.
4. Never allow children to operate a power tiller. Only persons well acquainted with these rules of safe operation should be allowed to use your tiller.
5. No one should operate this unit while intoxicated or while taking medication that impairs the senses or reactions.
6. Keep the area of operation clear of all persons, particularly small children and pets.
7. Do not operate equipment when barefoot or wearing open sandals. Always wear substantial footwear.
8. Do not wear loose fitting clothing that could get caught on the tiller.
9. Do not start the engine unless the shift lever is in the neutral (N) position.
10. Do not stand in front of the tiller while starting the engine.
11. Do not place feet and hands on or near the tines when starting the engine or while the engine is running.
12. Never attempt to make a wheel or depth bar adjustment while the engine is running.
13. Do not leave the tiller unattended with the engine running.
14. Do not walk in front of the tiller while the engine is running.
15. Check the fuel before starting the engine. Gasoline is an extremely flammable fuel. Do not fill gasoline tank indoors, while the engine is running, or while the engine is still hot. Replace gasoline cap securely, and wipe off any spilled gasoline before starting the engine as it may cause a fire or explosion.
16. Do not run the engine while indoors. Exhaust gases are deadly poisonous.
17. Be careful not to touch the muffler after the engine has been running. It is hot.
18. Do not change the engine governor settings or overspeed the engine. Excessive engine speeds are dangerous.
19. Before any maintenance work is performed or adjustments are made, remove the spark plug wire and ground it on the engine block for added safety.
20. Use caution when tilling near buildings and fences. Rotating tines can cause damage or injury.
21. Before attempting to remove rocks, bricks and other objects from tines, stop the engine and be sure the tines have stopped completely. Disconnect the spark plug wire and ground to prevent accidental starting.
22. Check the tine and engine mounting bolts at frequent intervals for proper tightness.
23. Keep all nuts, bolts and screws tight to be sure the equipment is in safe working condition.
24. Never store the equipment with gasoline in the tank inside of a building where fumes may reach an open flame or spark. Allow the engine to cool before storing in any enclosure.

ASSEMBLY INSTRUCTIONS

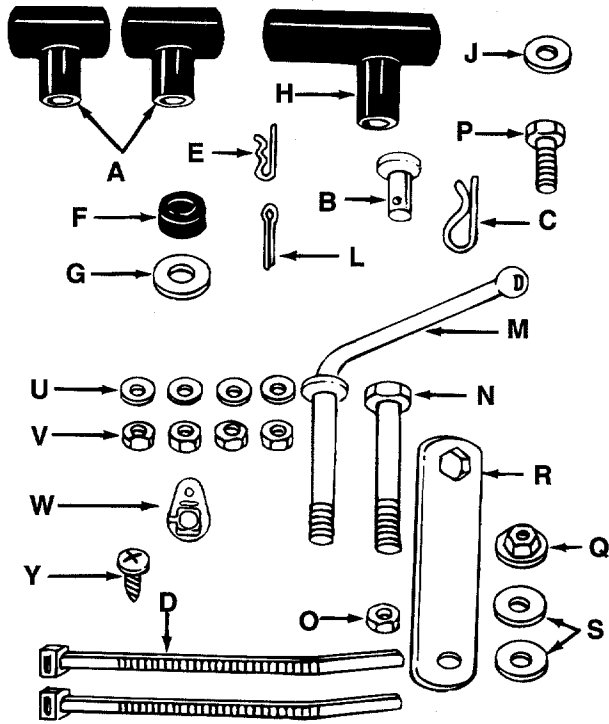

FIGURE 1.

NOTE: This unit is shipped **WITHOUT GASOLINE or OIL.** After assembly, see separate engine manual for proper fuel and engine oil recommendations.

NOTE: Left and right is determined from the operator's position, standing behind the tiller.

Contents of Hardware Pack: (See Figure 1)

- A (2) Small "T" Knobs
- B (1) Clevis Pin
- C (1) Large Hairpin Clip
- ← D (2) Cable Ties
- E (1) Small Hairpin Clip
- F (1) Rubber Washer
- G (1) Flat Washer 3/8" I.D. x 1.25" O.D.
- H (1) Large "T" Knob
- J (1) Flat Washer 3/8" I.D. x 5/8" O.D.
- L (1) Cotter Pin
- M (1) Handle Adjustment Lock
- N (1) Hex Bolt 3/8-16 x 3-1/4" Long
- O (1) Hex Nut 3/8-16 Thread
- P (1) Hex Bolt 3/8-16 x 1" Long
- Q (1) Shoulder Nut
- R (1) Hex Nut Retainer Bracket
- S (2) Belleville Washers 3/8" I.D.
- U (4) Belleville Washers 5/16" I.D.*
- V (4) Hex Nuts 5/16-18 Thread*
- W (1) Cable Hold-Down
- Y (1) Self-Tapping Screw 7/16" Long

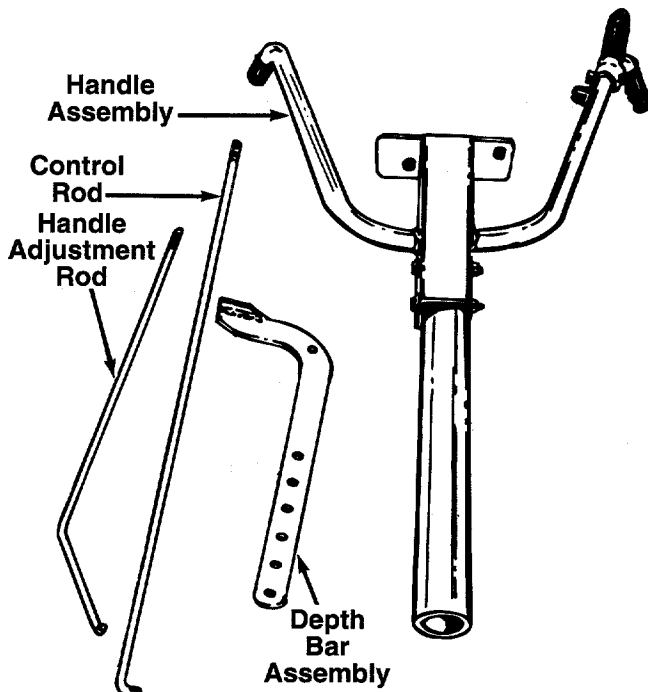

FIGURE 2.

Loose Parts in Carton: (See Figure 2)

- (1) Handle Assembly
 - (1) Control Rod
 - (1) Handle Adjustment Rod
 - ← (1) Depth Bar Assembly
 - (2) Side Shields* (Not Shown)
- *May be already assembled on your unit.

1. Remove tiller, loose parts and hardware pack from carton. Make certain all parts and literature have been removed from the carton before the carton is discarded.
2. Extend the control cable and lay on the floor. Be careful not to bend or kink control cable.

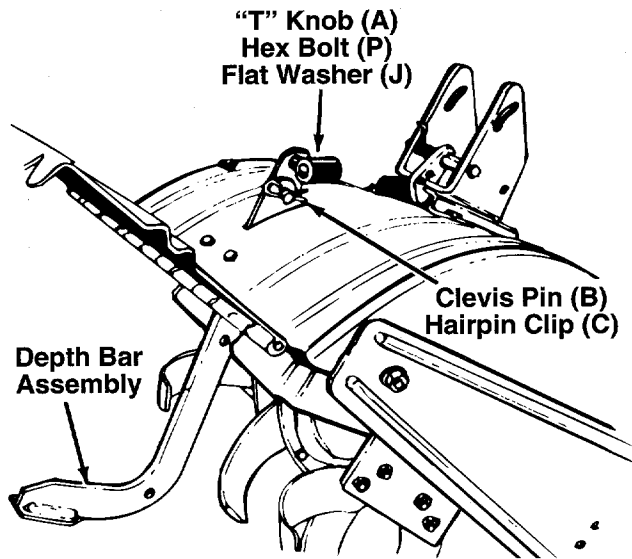

FIGURE 3.

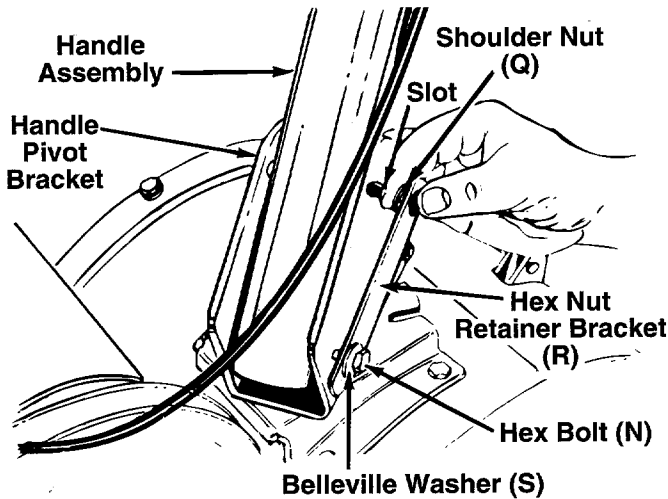

FIGURE 4.

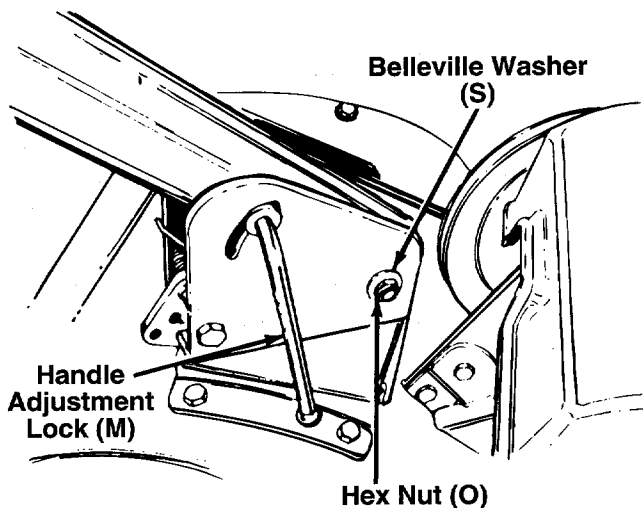

FIGURE 5.

3. Tip the tiller forward so it rests on front counterweight. See figure 3.
4. Raise the tine shield hinge flap assembly. Insert the depth bar assembly between the two shoulder bolts and up through the tine shield assembly as shown in figure 3.
5. Insert clevis pin (B) through the tine shield and depth bar assemblies. Secure with hairpin clip (C). See figure 3.
6. Insert hex bolt (P) into the upper hole of the depth bar assembly. Place flat washer (J) onto the hex bolt and thread small "T" knob (A) onto the hex bolt. See figure 3. Tighten securely.
7. Tip the tiller back down so it rests on the tines.
8. Place belleville washer (S) onto hex bolt (N) (crown side of washer goes against the bolt). Place hex nut retainer bracket (R) on hex bolt (N), using the round hole in retainer bracket.
9. Place handle assembly in position in the handle pivot bracket. Line up the holes in handle assembly with the holes (and slots) in the pivot bracket. See figure 4.
10. Insert hex bolt (with washer and hex nut retainer attached) through the bottom holes on the handle pivot bracket and handle assembly. Head of the hex bolt should be to the left hand side of the unit. See figure 4.
11. Place shoulder nut (Q) between hex nut retainer bracket and pivot bracket. See figure 4.
12. Secure bottom of handle by placing belleville washer (S) (cupped side against the pivot bracket) and hex nut (O) on hex bolt (N). Do not tighten at this time. See figure 5.
13. Insert handle adjustment lock (M) through handle pivot bracket and handle assembly. See figure 5. Thread end of handle adjustment crank into shoulder nut.
14. Pivot handle assembly into position desired. Tighten securely the bottom bolt and nut. Tighten the handle adjustment lock.

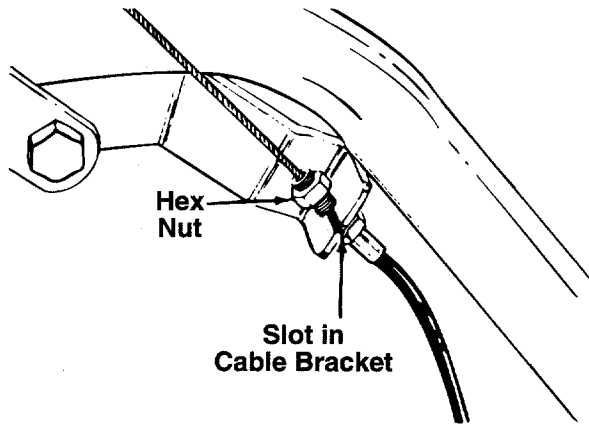

FIGURE 6.

Attach the clutch cable to the left handle as follows (be careful not to kink the cable).

15. Remove one hex nut from the end of the casing on the clutch cable. Slip the wire through the slot on the cable bracket on the left handle. Push the end of the casing up through the cable bracket. Rethread the hex nut on the end of the cable. Do not tighten at this time. See figure 6.

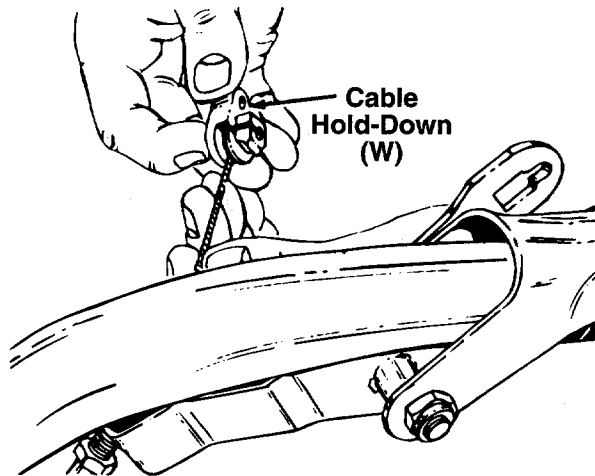

FIGURE 7.

16. Hook the barrel end of the cable into the cable hold-down (W). Slide the cable around in the slot as shown in figure 7.

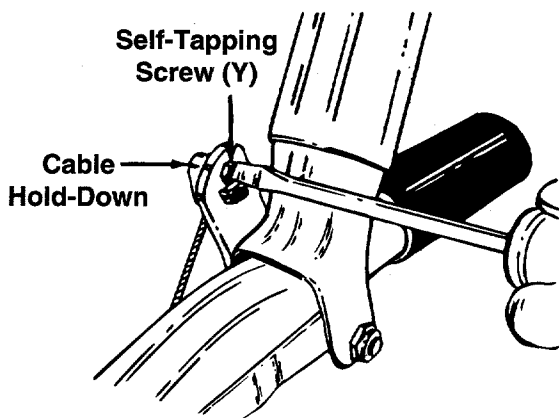

FIGURE 8.

17. Pull the cable upwards to obtain slack, lift the clutch grip, and insert the cable hold-down into the clutch grip. Secure with self-tapping screw (Y). See figure 8.



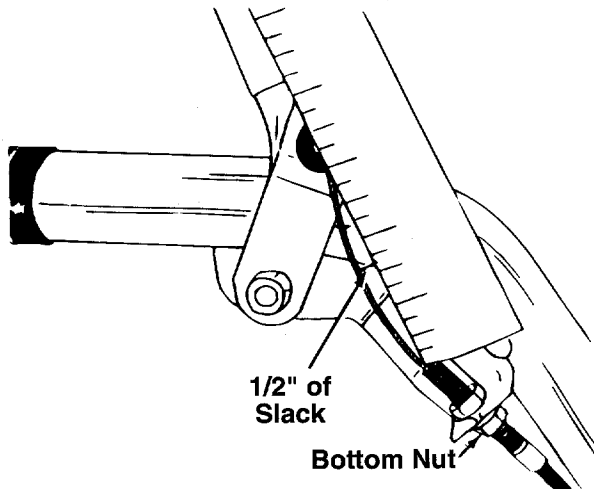

FIGURE 9.

18. With the clutch lever released (in the “up” position), adjust the bottom nut at the cable bracket so there is 1/2” of slack in the control wire as shown in figure 9. Tighten the upper nut against the bracket. Squeeze the clutch lever against the handle. The control wire should now be straight.

NOTE: Do not overtighten control wire. Too much tension may cause it to break.



WARNING: Be certain to check the clutch cable adjustment as instructed on page 7 of your owner’s guide before operating the tiller.

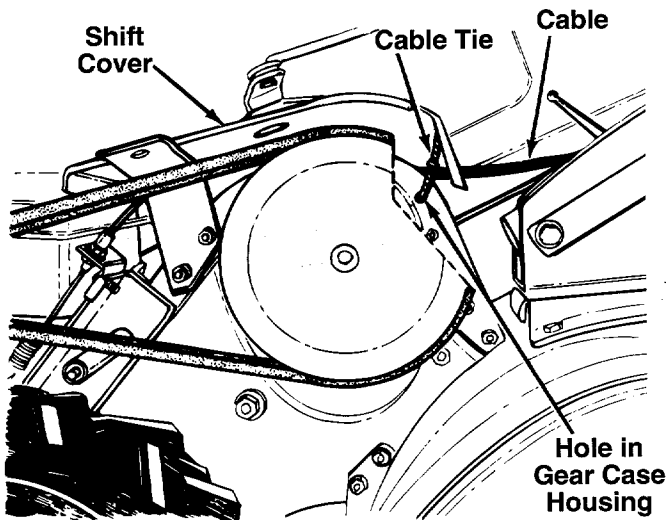

FIGURE 10.

19. Secure the drive cable to the top of the gear case housing (underneath the shift cover) using one of the cable ties (D) provided, keeping the cables away from the pulley. See figure 10. Cut off excess end of cable tie.

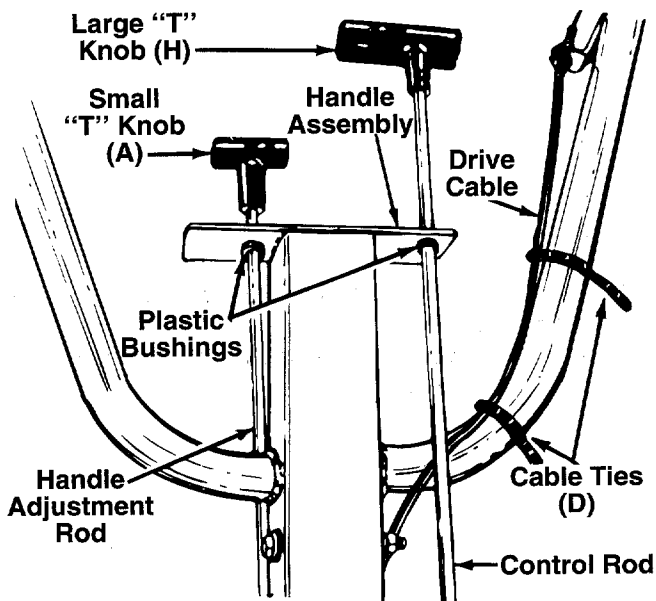

FIGURE 11.

20. Insert the threaded end of control rod up through the plastic bushing on the left side of handle assembly. See figure 11. Thread the large “T” knob (H) on the end of control rod.
21. Insert the threaded end of handle adjustment rod up through the plastic bushing on the right side of handle assembly. Thread the small “T” knob (A) on the end of handle adjustment rod.

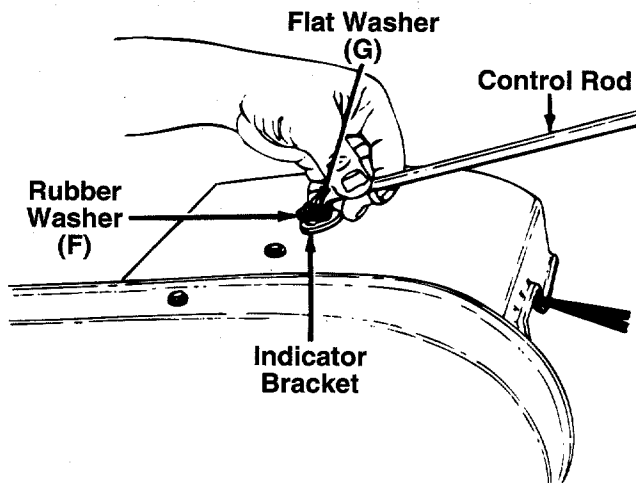

FIGURE 12.

22. Place flat washer (G), then rubber washer (F) over the hooked end of control rod. Insert end of control rod into the indicator bracket on top of the shift cover, and secure with hairpin clip (E). See figure 12.

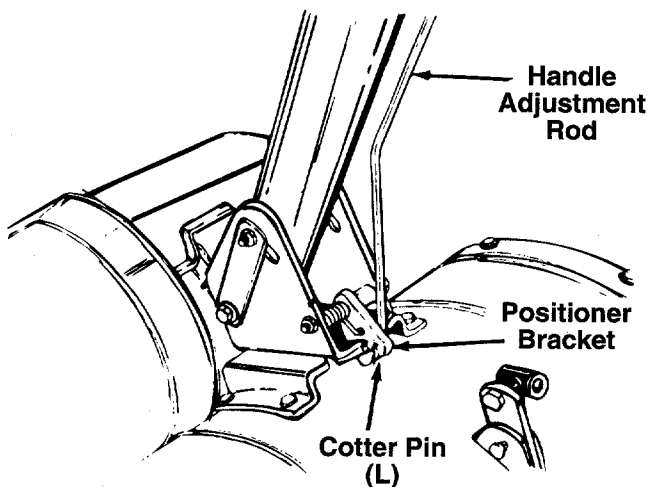

FIGURE 13.

23. Insert the hooked end of handle adjustment rod into the positioner bracket as shown in figure 13. Secure with cotter pin (L). Secure by bending ends of pin in opposite directions.

24. Secure drive cable to left handle using cable ties (D). Refer to figure 11. Cut off excess end of cable ties.

25. Check the clutch adjustment as follows.

IMPORTANT: Service the engine with oil and gasoline before checking this adjustment. Refer to the separate engine manual packed with your tiller.

- a. Position the tiller so the front counterweight is against a solid object, such as a wall. With the gear selection lever in NEUTRAL, start the engine.
- b. Standing on the right side of the tiller, examine the belt (inside the belt cover). It should not be turning.

If the belt turns with the unit in neutral, adjust by moving the hex nut below the cable bracket **down** a few turns. See figure 14. Tighten the upper hex nut against the bracket.

- c. Now move the shift lever to FORWARD (Wheels Forward) position. Carefully engage the clutch by squeezing the clutch lever against the left handle. The wheels should spin.

If the wheels do not spin with the unit in forward, adjust by moving the hex nut which is above the cable bracket **up** a few turns. Tighten the bottom hex nut against the bracket.

Recheck both adjustments, and readjust as necessary.

NOTE: If you reach the point that additional adjustment is needed, remove the belt cover and move the hex nuts at the other end of the cable towards the end of the casing. Then readjust the hex nuts at the handle.

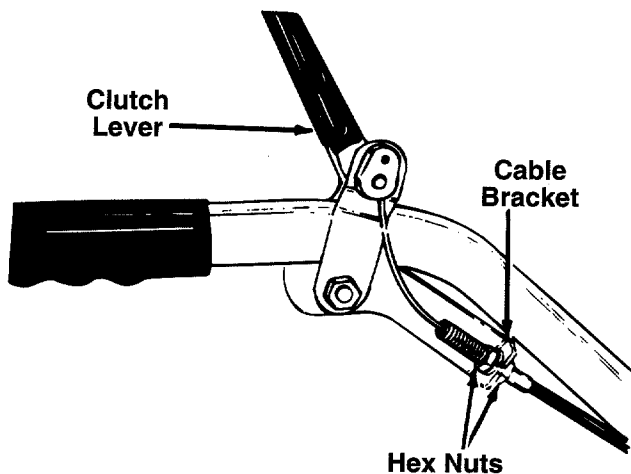

FIGURE 14.

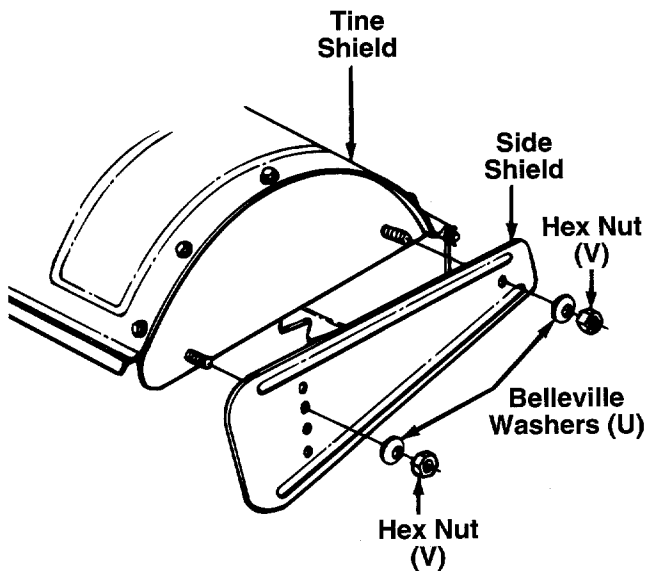

FIGURE 15.

26. Assemble the side shields to the tine shield using belleville washers (U) (cupped side against the side shields) and hex nuts (V) as shown in figure 15. The side shields will be adjusted up or down as the depth bar is adjusted. Refer to "How to Use Your Tiller" on page 9.

27. The tires on your unit may be over-inflated for shipping purposes. Reduce the tire pressure before operating the unit. Recommended operating tire pressure is approximately 12 p.s.i. (check sidewall of tire for tire manufacturer's recommended pressure).



WARNING: Maximum tire pressure under any circumstances is 30 p.s.i. Equal tire pressure should be maintained on both tires.

CONTROLS

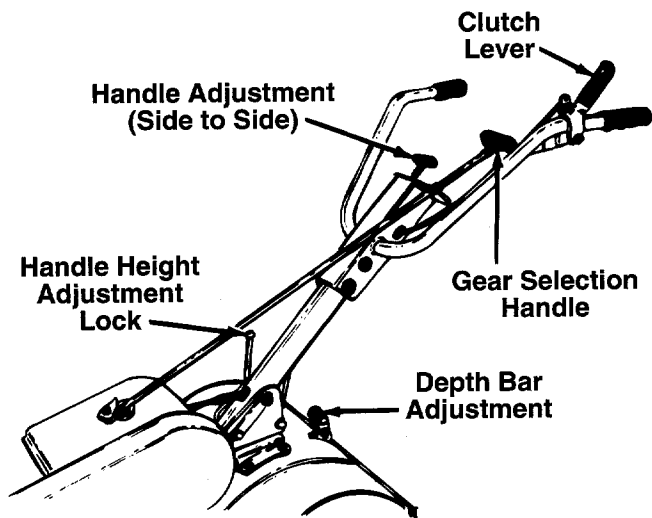

FIGURE 16.

THROTTLE CONTROL

The throttle control lever is located on the engine. It controls the engine speed and stops the engine. See figure 17.

GEAR SELECTION HANDLE

The gear selection handle is located towards the left side of the tiller. See figure 16. It is used to select NEUTRAL, REVERSE, or one of the FORWARD modes (see below). Pull or push the handle so that the indicator on top of shift cover points to the operating mode desired.

NEUTRAL—Transmission is in neutral.

REVERSE—Reverse wheel drive.

FORWARD Modes:

Wheels Forward— Forward wheel drive only.

Tines Reverse— Forward wheel drive and reverse tine drive.

Tines Forward— Forward wheel and tine drive.



WARNING: Make certain unit is in NEUTRAL when starting the engine.

CLUTCH LEVER

The clutch lever is located on the left handle. See figure 16. Squeezing the clutch lever against the handle engages the wheel and tine drive mechanisms.

DEPTH BAR

The depth bar controls the tilling depth. Refer to "How to Use Your Tiller" section on page 9.

HANDLE ADJUSTMENT (See Figure 16)

The handle may be adjusted to be in line with the tiller, or swung to the left or right so the operator is not walking in the freshly tilled soil.

To adjust the handle position from side to side, pull the handle adjustment lever back, pivot the tiller handle to desired position and release the lever.

The handle may also be adjusted to the height desired. Loosen the handle height adjustment lock a few turns. Pivot handle up or down to desired position. Tighten lock.

OPERATION

NOTE: Engine is shipped without oil.



WARNING: Before operating the tiller, be certain to read "How to Use Your Tiller" on page 9. Use the reverse tine drive when tilling virgin ground, sod or hard soil. Use the forward tine drive when cultivating or tilling soft ground.

BEFORE STARTING

1. Service engine with oil as instructed in the separate engine manual packed with your unit.
2. Fill fuel tank with clean, fresh, lead-free, low-lead or regular grade leaded gasoline.
3. Be certain to check clutch adjustment as described in step 25 of Assembly Instructions.

TO START ENGINE



WARNING: BE SURE NO ONE IS STANDING IN FRONT OF THE TILLER WHILE THE ENGINE IS RUNNING OR BEING STARTED.

1. Place gear selection lever in NEUTRAL.
2. Place the throttle control lever in START position. See figure 17.
3. Move choke lever to CHOKE position.

NOTE: A warm engine may not require choking.

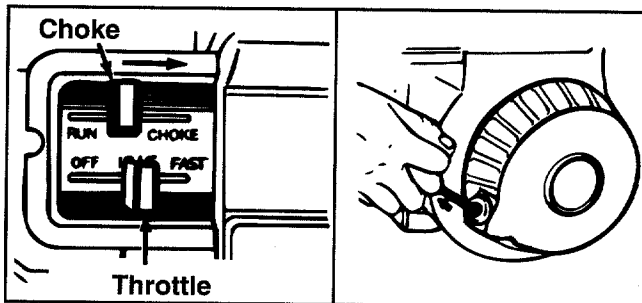

FIGURE 17.

4. Stand at side of tiller. Grasp the starter handle and pull out slowly, until it pulls slightly harder. Let rope rewind slowly.
5. Pull starter handle rapidly. Do not allow handle to snap back. Allow it to rewind slowly while keeping a firm hold on the starter handle.
6. Repeat steps 4 and 5 until engine starts.
7. As engine warms up and begins to operate evenly, move choke lever gradually to RUN position. If engine falters, return to choke position, then slowly move to RUN position. Refer to engine manual for additional engine information.

TO STOP ENGINE

1. Move throttle control to OFF position.
2. Disconnect spark plug wire and ground to prevent accidentally starting while equipment is unattended.

NOTE: After the first ten hours of operation, recheck the clutch adjustment. Refer to step number 25 of the Assembly Instructions.

HOW TO USE YOUR TILLER



WARNING: When operating the tiller for the first time, use the depth bar setting that gives 1-1/2 inches of tilling depth (second hole from the top). Refer to figure 18.

Tilling depth is controlled by the depth bar which can be adjusted to five different settings. See figure 18. Adjust the side shields as shown in figure 19, as you adjust the depth bar. Be certain spark plug wire is disconnected and grounded against the engine.

1. When using the tiller for the first time, use the second adjustment hole from the top (1-1/2" of tilling depth). See figure 18.

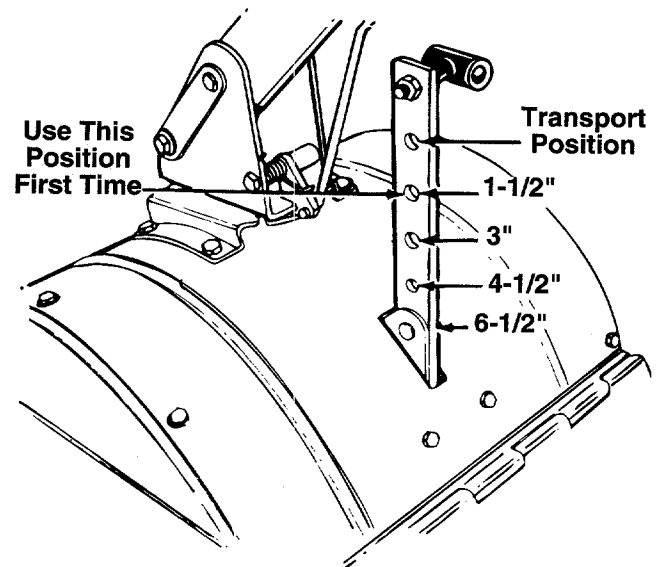

FIGURE 18.

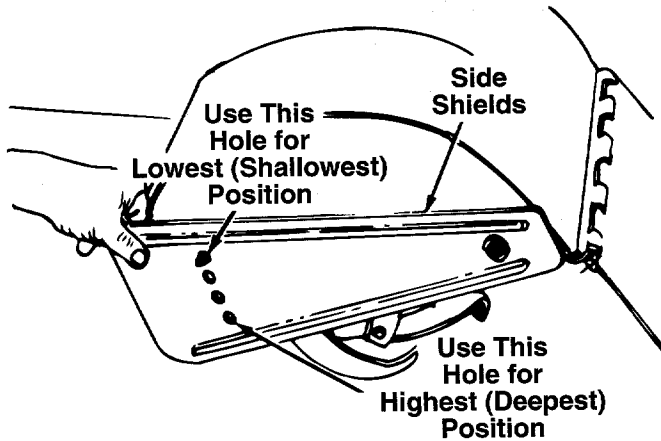

FIGURE 19.

2. When breaking up sod and for shallow cultivation, use the setting which gives 1-1/2" of tilling depth (second hole from the top). Place the side shields in their lowest position. For further depth, raise the depth bar and side shields and make one or two more passes over the area.
3. When tilling loose soil, depth bar may be raised to its highest position (use bottom adjustment hole) to give the deepest tilling depth. Raise the side shields to their highest position.
4. To transport tiller, lower the depth bar (use top adjustment hole).

To adjust the depth bar, remove the clevis pin and hairpin clip. See figure 18. Move the depth bar to the desired setting.

To adjust the side shields, remove the hex nut and Belleville washer from the front and loosen the rear nut. See figure 19. Pivot the side shield to the desired position. Replace hex nut and Belleville washer. Tighten securely.

To operate the tiller:

1. Select the depth bar setting.
2. Start engine as instructed on page 8.
3. Move gear selection handle to one of the forward modes or reverse. **Use the reverse tine drive when tilling virgin ground, sod or hard soil. Use the forward tine drive when cultivating or tilling soft ground.**

IMPORTANT: When using the forward tine drive, lower the depth bar (use a shallower tilling depth) to make certain the tines do not run across the ground.



WARNING: Do not move the gear selection handle with the wheels or tines engaged. Make certain the unit is stopped completely before changing the gear selection.

4. Squeeze the clutch lever against the handle to engage the wheels and tines.

NOTE: Make certain the gear selection indicator is correctly positioned before engaging the clutch handle. If it is between gears, the engine will stall.

To transport tiller, **do not** engage the tines. Select the wheel drive only.



WARNING: Do not push down on the handles so that the wheels are lifted off the ground while using the reverse tine drive, or the tiller could move backward and cause personal injury.

For best results, it is recommended the garden be tilled twice (lengthwise, then widthwise) to pulverize the soil.

ADJUSTMENTS

HANDLE ADJUSTMENT

The handle may be adjusted to be in line with the tiller, or swung to the left or right. The handle height may also be adjusted. Refer to the Control section for details of handle adjustment.

BELT TENSION ADJUSTMENT

Periodic adjustment of the belt tension may be required due to normal stretch and wear on the belt. Adjustment is needed if the tines or wheels seem to hesitate while turning, but the engine maintains the same speed.

To adjust to the tension on the belt, refer to clutch adjustment information in step number 25 of the Assembly Instructions.

CARBURETOR ADJUSTMENT



WARNING: If any adjustments are made to the engine while the engine is running, (e.g. carburetor), disengage all clutches and tines. Keep clear of all moving parts. Be careful of heated surfaces and muffler.

Never make unnecessary adjustments. The factory settings are correct for most applications. If adjustments are needed, refer to the separate engine manual packed with your tiller.

LUBRICATION

Transmission—The transmission is pre-lubricated and sealed at the factory. It requires no checking unless the transmission is disassembled. To fill with grease, lay the right half of the transmission on its side. Add 27 ounces of Benalene #372-0 grease. Assemble the left half to it. This grease can be obtained at your nearest authorized dealer. Order part number 737-0223.

Clutch Lever—Lubricate the pivot point on the clutch lever and the cable at least once a season with light oil. The control must operate freely in both directions.

Pivot Points—Lubricate all pivot points and linkages at least once a season with light oil.

MAINTENANCE



WARNING: Disconnect the spark plug wire and ground it against the engine before performing any repairs or maintenance.

ENGINE

Refer to the separate engine manual for engine maintenance instructions.

Maintain **engine oil** as instructed in the separate engine manual packed with your unit. Read and follow instructions carefully.

Service **air cleaner** every ten hours under normal conditions. Clean every hour under extremely dusty conditions. Poor engine performance and flooding usually indicates that the air cleaner should be serviced. To service the air cleaner, refer to the separate engine manual packed with your unit.

IMPORTANT: Never run your engine without air cleaner completely assembled.

The **spark plug** should be cleaned and the gap reset every 25 hours of engine operation. Spark plug replacement is recommended at the start of each tiller season; check engine manual for correct plug type and gap specification.

Clean the engine regularly with a cloth or brush. Keep the cooling system (blower housing area) clean to permit proper air circulation which is essential to engine performance and life. Be certain to remove all dirt and combustible debris from muffler area.

CLEANING THE TINE AREA

Clean the underside of the tine shield after each use. The dirt washes off the tines easier if washed off immediately instead of after it dries.

TIRES

Recommended operating tire pressure is approximately 12 p.s.i. (check sidewall of tire for tire manufacturer's recommended pressure). Maximum tire pressure under any circumstances is 30 p.s.i. Equal tire pressure should be maintained on both tires. When installing a tire to the rim, be certain rim is clean and free of rust. Lubricate both the tire and rim generously. Never inflate to over 30 p.s.i. to seat beads.



WARNING: Excessive pressure (over 30 p.s.i.) when seating beads may cause tire/rim assembly to burst with force sufficient to cause serious injury.

BELT REPLACEMENT



CAUTION: Do not use an off-the-shelf belt.

Your tiller has been engineered with a belt made of special material (Kevlar Tensile) for longer life and better performance. It should not be replaced with an off-the-shelf belt.

If belt replacement is required, order belt or belts by part number from your nearest authorized dealer. Part No. 754-0267—"V" Belt

1. Disconnect and ground the spark plug wire against the engine.
2. Remove the belt cover from the left side of the tiller as follows. See figure 20.
 - a. Remove two self-tapping screws and flat washers from the top of belt cover.
 - b. Remove the hex cap nut and flat washer from the side of the belt cover. Remove the hex nut and flat washer at the bottom of the front of the cover.

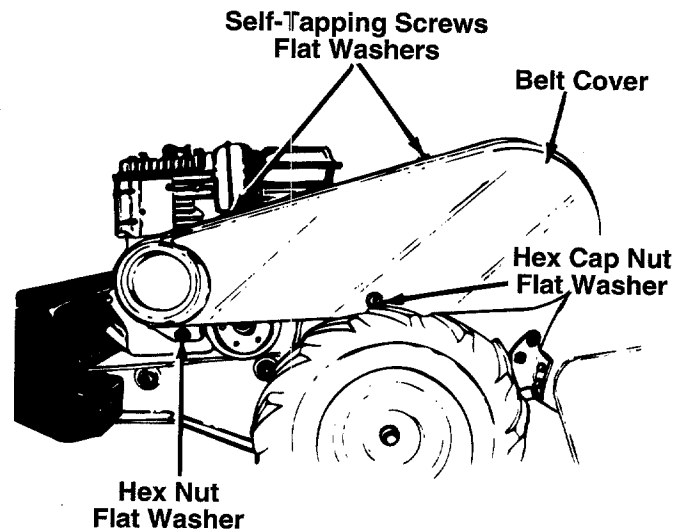

FIGURE 20.

3. Remove the hex bolt (belt keeper) located beneath the engine pulley. See figure 21.
4. Remove belt. Reassemble new belt, following instructions in reverse order.

NOTE: Upon reassembly, make certain the belt is routed over the idler pulley and inside of belt keepers by engine pulley. See figure 21.

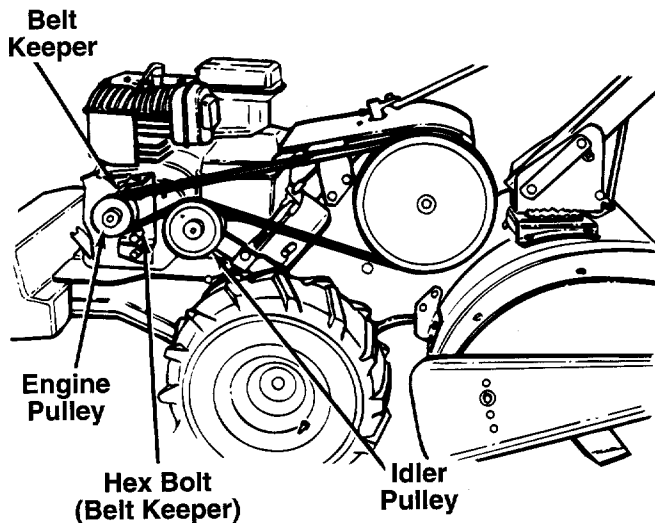

FIGURE 21.

OFF-SEASON STORAGE

If the tiller will not be used for a period longer than 30 days, the following steps should be taken to prepare the tiller for storage.

1. Clean the exterior of engine and the entire tiller thoroughly. Lubricate the tiller as described in the lubrication instructions.
2. Refer to the engine manual for correct engine storage instructions.
3. Wipe tines with oiled rag to prevent rust.
4. Store tiller in a clean, dry area. Do not store next to corrosive materials, such as fertilizer.

NOTE: When storing any type of power equipment in an unventilated or metal storage shed, care should be taken to rustproof the equipment. Using a light oil or silicone, coat the equipment, especially any springs, bearings and cables.

TROUBLE SHOOTING GUIDE

Trouble	Possible Cause(s)	Corrective Action
Engine fails to start	<ol style="list-style-type: none"> 1. Fuel tank empty, or stale fuel. 2. Throttle control lever not in starting position. 3. Spark plug wire disconnected. 4. Faulty spark plug. 5. Engine flooded. 	<ol style="list-style-type: none"> 1. Fill tank with clean, fresh gasoline. 2. Move throttle lever to START position. 3. Connect wire to spark plug. 4. Clean, adjust gap or replace. 5. Crank engine with throttle in FAST position.
Engine runs erratic	<ol style="list-style-type: none"> 1. Unit running on CHOKE. 2. Spark plug wire loose. 3. Stale fuel. 4. Vent in gas cap plugged. 5. Water or dirt in fuel system. 6. Dirty air cleaner. 7. Carburetor out of adjustment. 	<ol style="list-style-type: none"> 1. Move choke lever to OFF position. 2. Connect and tighten spark plug wire. 3. Fill tank with clean, fresh gasoline. 4. Clear vent. 5. Drain fuel tank. Refill with fresh fuel. 6. Clean air cleaner as instructed in separate engine manual. 7. Adjust carburetor as instructed in separate engine manual.
Engine overheats	<ol style="list-style-type: none"> 1. Engine oil level low. 2. Air flow restricted. 3. Carburetor not adjusted properly. 	<ol style="list-style-type: none"> 1. Fill crankcase with proper oil. 2. Remove blower housing and clean as instructed in separate engine manual. 3. Adjust carburetor as instructed in separate engine manual.
Tines do not engage	<ol style="list-style-type: none"> 1. Foreign object lodged in tines. 2. Tine clevis pin(s) missing. 3. Control cable not adjusted properly. 4. Belt worn and/or stretched. 	<ol style="list-style-type: none"> 1. Dislodge foreign object. 2. Replace tine clevis pin(s). 3. Adjust control cable (see assembly instructions). 4. Replace belt.
Wheels do not engage	<ol style="list-style-type: none"> 1. Control cable not adjusted properly. 2. Belt worn and/or stretched. 	<ol style="list-style-type: none"> 1. Adjust control cable (see assembly instructions). 2. Replace belt.

NOTE: For repairs beyond the minor adjustments listed above, please contact your local service dealer.

The only way to insure the performance of your product is to use original equipment parts and accessories. Cub Cadet designs and engineers quality parts to exacting specifications. When you substitute, you take a chance on quality, reliability, safety and performance. Use Cub Cadet original equipment parts—See your local Cub Cadet dealer!

Clutch Control Cable	746-0908
Throttle Wire	746-0513
V-Belt	754-0267
Idler Pulley	756-0405
Spark Plug	759-3338
Air Filter	BS-491588
Air Filter—Pre-Cleaner	BS-491435



Power Equipment

LIMITED WARRANTY

**TWO-YEAR RESIDENTIAL
ONE-YEAR COMMERCIAL**

Proper maintenance of your Cub Cadet equipment is the owner's responsibility. Follow the instructions in your owner's manual for correct lubricants and maintenance schedule. Your Cub Cadet dealer carries a complete line of quality lubricants and filters for your equipment's engine, transmission, chassis and attachments.

RIDING MOWERS, LAWN TRACTORS, GARDEN TRACTORS, CUB CADET ATTACHMENTS AND HOME MAINTENANCE PRODUCTS

This limited warranty for residential users, covers any defect in materials or workmanship in your Cub Cadet equipment for two years from the date of purchase for the first user purchaser.

We will replace or repair any part or parts without charge through your authorized Cub Cadet dealer.

Batteries have a one-year prorated limited warranty with 100% replacement during the first three months.

V-belts for either the traction drive or any attachments are covered for one year only.

Cub Cadet equipment used commercially is warranted for one year only.

(Commercial use is defined as either having hired operators or used for income producing purpose.)

ITEMS NOT COVERED

The warranty does not cover routine maintenance items such as lubricants, filters (oil, fuel, air and hydraulic), cleaning, tune-ups, brake and/or clutch inspection, adjustments made as part of normal maintenance, blade sharpening, set-up, abuse, accidents and normal wear. It does not cover incidental costs such as transporting your equipment to and from the dealer, telephone charges or renting a product temporarily to replace a warranted product.

There is no other express warranty.

HOW TO OBTAIN SERVICE

Contact your authorized Cub Cadet servicing dealer who sold you your Cub Cadet equipment. If this dealer is not available, see the Consumer Yellow Pages under "lawn mowers" for the name of a dealer near you.

If you need further assistance in finding an authorized Cub Cadet servicing dealer, contact:

Cub Cadet Corporation
Post Office Box 368023
Cleveland, Ohio 44136-9723

HOW DOES STATE LAW APPLY?

This limited warranty gives you specific legal rights, and you may also have other rights which vary from state to state.