



Operator's Manual



Single Stage Snow Thrower

Model 421R

IMPORTANT: Read safety rules and instructions carefully

Warning: This unit is equipped with an internal combustion engine and should not be used on or near any unimproved forest-covered, brush-covered or grass-covered land unless the engine's exhaust system is equipped with a spark arrester meeting applicable local or state laws (if any). If a spark arrester is used, it should be maintained in effective working order by the operator. In the State of California the above is required by law (Section 4442 of the California Public Resources Code). Other states may have similar laws. Federal laws apply on federal lands. A spark arrester for the muffler is available through your nearest engine authorized service dealer or contact the service department, P.O. Box 368023 Cleveland, Ohio 44136-9722.

CUB CADET CORP. P.O. BOX 368023 CLEVELAND, OHIO 44136-9722

PRINTED IN U.S.A.
ECO No. 1405

FORM NO. 770-10005B
(6/2000)

TABLE OF CONTENTS

Content	Page
Important Safe Operation Practices	3
Assembling Your Snow Thrower	5
Know Your Snow Thrower.....	7
Operating Your Snow Thrower	8
Making Adjustments.....	9
Maintaining Your Snow Thrower	10
Off-Season Storage	11
Troubleshooting	12
Parts List	13

FINDING MODEL NUMBER

This Operator's Manual is an important part of your new snow thrower. It will help you to assemble, prepare and maintain the unit for best performance. Please read and understand what it says.



Before you start assembling your new snow thrower, please locate the model plate on the equipment and copy the information from it in the space provided below. The information on the model plate is very important if you need help from our Customer Support Department or an authorized dealer.

- You can locate the model number by standing behind the unit in the operating position and looking down at the dash panel . A sample model plate is explained below. For future reference, please copy the model number and the serial number of the equipment in the space below.

_____	_____
(Model Number)	(Serial Number)
 CUB CADET CORP. P.O. BOX 368023 CLEVELAND, OHIO 44136	

Copy the model number here: _____

Copy the serial number here: _____

CALLING CUSTOMER SUPPORT



If you have difficulty assembling this product or have any questions regarding the controls, operation or maintenance of this unit, please call the Cub Cadet Customer Dealer Referral Line at **1-(800)-528-1009**. Please have your unit's model number and serial number ready when you call. See previous section to locate this information. By having the model and serial numbers ready, you help your Cub Cadet dealer give you faster service.

For more details about your machine, visit our website at www.cubcadet.com

SECTION 1: IMPORTANT SAFE OPERATION PRACTICES



WARNING: This symbol points out important safety instructions which, if not followed, could endanger the personal safety and/or property of yourself and others. Read and follow all instructions in this manual before attempting to operate this machine. Failure to comply with these instructions may result in personal injury. When you see this symbol—**heed its warning.**



WARNING: Engine Exhaust, some of its constituents, and certain vehicle components contain or emit chemicals known to State of California to cause cancer and birth defects or other reproductive harm.



DANGER: This machine was built to be operated according to the rules for safe operation in this manual. As with any type of power equipment, carelessness or error on the part of the operator can result in serious injury. This machine is capable of amputating hands and feet and throwing objects. Failure to observe the following safety instructions could result in serious injury or death.

Training

1. Read, understand, and follow all instructions on the machine and in the manual(s) before attempting to assemble and operate. Keep this manual in a safe place for future and regular reference and for ordering replacement parts.
2. Be familiar with proper operation of all controls. Know how to stop the machine and disengage controls quickly.
3. Never allow children under 14 years to operate this machine. Children 14 years and over should read and understand the operation instructions and safety rules in this manual and should be trained and supervised by a parent.
4. Never allow adults to operate this machine without proper instruction.
5. Thrown objects can cause serious personal injury. Plan your snow throwing pattern to avoid discharge of material toward roads, bystanders and the like.
6. Keep bystanders, helpers, pets and children at least 75 feet from the machine while it is in operation. Stop machine if anyone enters the area.
7. Exercise caution to avoid slipping or falling, especially when operating in reverse.
8. Let engine and machine adjust to outdoor temperature before starting to clear snow.
9. To avoid personal injury or property damage use extreme care in handling gasoline. Gasoline is extremely flammable and the vapors are explosive. Serious personal injury can occur when gasoline is spilled on yourself or your clothes which can ignite. Wash your skin and change clothes immediately.
 - a. Use only an approved gasoline container.
 - b. Extinguish all cigarettes, cigars, pipes and other sources of ignition.
 - c. Never fuel machine indoors.
 - d. Never remove gas cap or add fuel while the engine is hot or running.
 - e. Allow engine to cool at least two minutes before refueling.
 - f. Never over fill fuel tank. Fill tank to no more than ½ inch below bottom of filler neck to provide space for fuel expansion.
 - g. Replace gasoline cap and tighten securely.
 - h. If gasoline is spilled, wipe it off the engine and equipment. Move machine to another area. Wait 5 minutes before starting the engine.
 - i. Never store the machine or fuel container inside where there is an open flame, spark or pilot light (e.g. furnace, water heater, space heater, clothes dryer etc.).
 - j. Allow machine to cool at least 5 minutes before storing.

Preparation

1. Thoroughly inspect the area where the equipment is to be used. Remove all door mats, newspapers, sleds, boards, wires and other foreign objects which could be tripped over or thrown by the auger/impeller.
2. Always wear safety glasses or eye shields during operation and while performing an adjustment or repair to protect your eyes. Thrown objects which ricochet can cause serious injury to the eyes.
3. Do not operate without wearing adequate winter outer garments. Do not wear jewelry, long scarves or other loose clothing which could become entangled in moving parts. Wear footwear which will improve footing on slippery surfaces.
4. Use a grounded three wire extension cord and receptacle for all units with electric start engines.
5. Adjust collector housing height to clear gravel or crushed rock surfaces.
6. Disengage all clutch levers before starting the engine.
7. Never attempt to make any adjustments while engine is running, except where specifically recommended in the operator's manual.

Operation

1. Do not put hands or feet near rotating parts, in the auger/impeller housing or discharge chute. Contact with the rotating parts can amputate hands and feet.
2. The auger/impeller clutch lever is a safety device. Never bypass its operation. Doing so, makes the machine unsafe and may cause personal injury.
3. The clutch levers must operate easily in both directions, and automatically return to the disengaged position when released.
4. Never operate with a missing or damaged discharge chute. Keep all safety devices in place and working.
5. Never run an engine indoors or in a poorly ventilated area. Engine exhaust contains carbon monoxide, an odorless and deadly gas.

6. Do not operate machine while under the influence of alcohol or drugs.
7. Muffler and engine become hot and can cause a burn. Do not touch.
8. Exercise extreme caution when operating on or crossing gravel surfaces. Stay alert for hidden hazards or traffic.
9. Exercise caution when changing direction and while operating on slopes.
10. Plan your snow throwing pattern to avoid discharge towards windows, walls, cars etc. To avoid property damage or personal injury caused by a ricochet.
11. Never direct discharge at children, bystanders and pets or allow anyone in front of the machine.
12. Do not overload machine capacity by attempting to clear snow at too fast of a rate.
13. Never operate this machine without good visibility or light. Always be sure of your footing and keep a firm hold on the handles. Walk, never run.
14. Disengage power to the auger/impeller when transporting or not in use.
15. Never operate machine at high transport speeds on slippery surfaces. Look down and behind and use care when in reverse.
16. If the machine should start to vibrate abnormally, stop the engine, disconnect the spark plug and ground it against the engine. Inspect thoroughly for damage. Repair any damage before starting and operating.
17. Disengage all clutch levers and stop engine before you leave the operating position (behind the handles). Wait until the auger/impeller comes to a complete stop before unclogging the discharge chute, making any adjustments, or inspections.
18. Never put your hand in the discharge or collector openings. Always use a clearing tool to unclog the discharge opening.
19. Use only attachments and accessories approved by the manufacturer (e.g. wheel weights, tire chains, cabs etc.).
20. If situations occur which are not covered in this manual, use care and good judgment. Contact your dealer or telephone 1-800-528-1009 for assistance and the name of your nearest servicing dealer.

Maintenance And Storage

1. Never tamper with safety devices. Check their proper operation regularly.
2. Disengage all clutch levers and stop engine. Wait until the auger/impeller come to a complete stop. Disconnect the spark plug wire and ground against the engine to prevent unintended starting before cleaning, repairing, or inspecting.
3. Check bolts, and screws for proper tightness at frequent intervals to keep the machine in safe working condition. Also, visually inspect machine for any damage.
4. Do not change the engine governor setting or over-speed the engine. The governor controls the maximum safe operating speed of the engine.
5. Snow thrower shave plates and skid shoes are subject to wear and damage. For your safety protection, frequently check all components and replace with original equipment manufacturer's (O.E.M.) parts only. "Use of parts which do not meet the original equipment specifications may lead to improper performance and compromise safety!"
6. Check clutch controls periodically to verify they engage and disengage properly and adjust, if necessary. Refer to the adjustment section in this operator's manual for instructions.
7. Maintain or replace safety and instruction labels, as necessary.
8. Observe proper disposal laws and regulations for gas, oil, etc. to protect the environment.
9. Prior to storing, run machine a few minutes to clear snow from machine and prevent freeze up of auger/impeller.
10. Never store the machine or fuel container inside where there is an open flame, spark or pilot light such as a water heater, furnace ,clothes dryer etc.
11. Always refer to the operator's manual for proper instructions on off-season storage.

Your Responsibility:

- Restrict the use of this power machine to persons who read, understand and follow the warnings and instructions in this manual and on the machine.

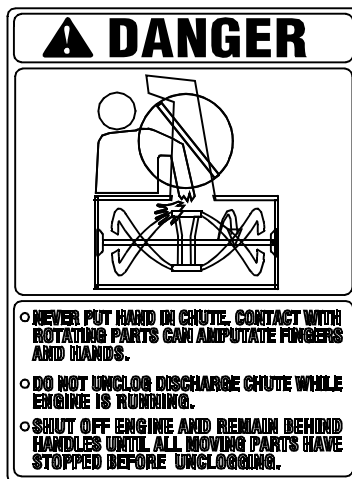
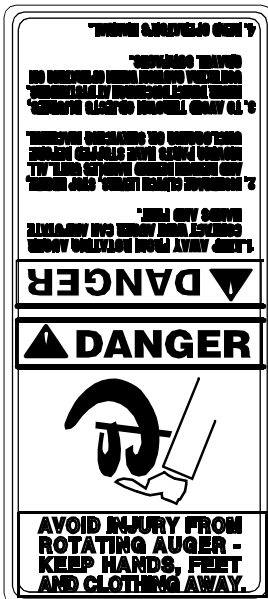

SECTION 2: ASSEMBLING YOUR SNOW THROWER

Unpacking From Carton

- Cut along corners of the carton and lay it down flat. See Figure 1. Remove packing material.
- Remove any loose parts included with unit (i.e., operator's manual, etc.).
- Roll unit out of carton. Check carton thoroughly for any remaining loose part.

Remove loose parts

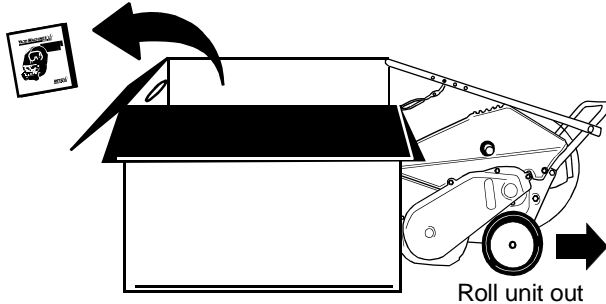

Figure 1

Hardware Pack

1. Ignition Keys* (2)

*One key may be in the switch on snow thrower.

(Items 2 to 5 are illustrated in Figure 2.)

2. Eyebolt
3. Saddle Washer 5/16" I.D.
4. Hex Nuts 5/16-18 Thread (2)
5. Cotter Pin

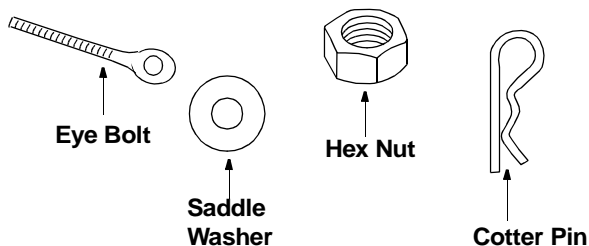

Figure 2: Hardware Pack

Items Required For Assembly

1. Pair of pliers (not necessary, but helpful)
2. Two cycle engine oil (included)
3. Fresh gasoline

NOTE: All references to left or right side of the snow thrower is from the operating position only.

Before Assembly



WARNING: Disconnect the spark plug wire and ground it against the engine to prevent unintended starting.

Raising Upper Handle

- Loosen the hand knob on each side of the handle. Remove packing material, if any.

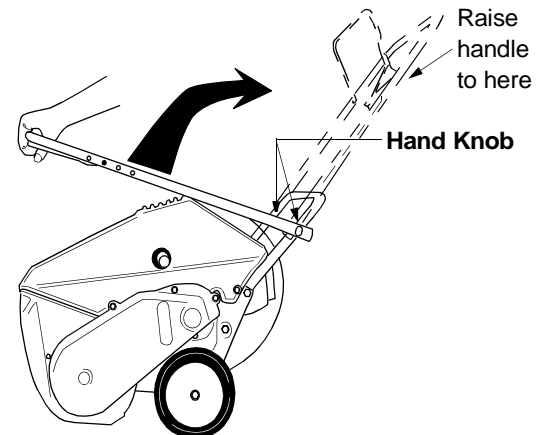

Figure 3

- Raise the upper handle in the direction shown in Figure 3 till it clicks into the operating position. Make sure not to pinch or crimp the cable.
- Tighten the hand knobs.

Attaching Control Cable

The control cable may already be attached to the control handle. If not attached, complete the following steps to attach it to the snow thrower housing.

- Route the control cable over the lower handle. Insert the end of the cable into the hole in the control housing as shown in Figure 4. Push the plastic fitting until it locks into the control housing.

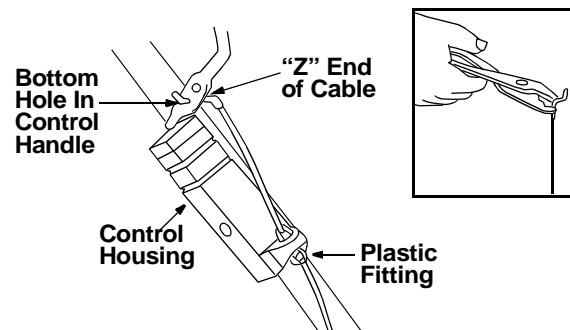

Figure 4

- Lift the control handle up, and hook the “Z” end of the control cable into the **bottom** hole in the control handle, from the outside to the inside . If necessary, pull up on the end of the cable with a pair of pliers to obtain slack in order to hook it into the control handle. Hold the “Z” fitting with the pliers, not the cable, to avoid damaging the cable.

NOTE: The upper hole in the control handle provides for adjustment in belt tension. Refer to page 9 of this manual for instructions.

Installing Chute Crank

- Thread one 5/16” hex nut all the way onto the eyebolt. See Figure 5. All necessary hardware is included in the hardware pack shipped with your unit. See Figure 2 for more details.
- Slide the eyebolt onto the chute crank. Insert eyebolt into the hole in the lower handle.

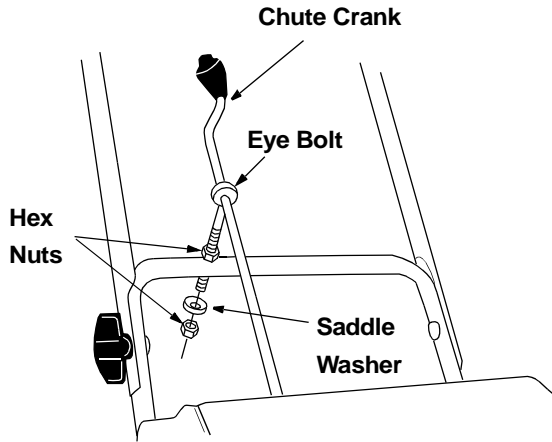

Figure 5

- Insert the chute crank into the coupler at the top right side of the snow thrower. See Figure 6.
- Rotate the crank to align holes, and insert the cotter pin. Bend ends of cotter pin in opposite directions to secure. See Figure 6.

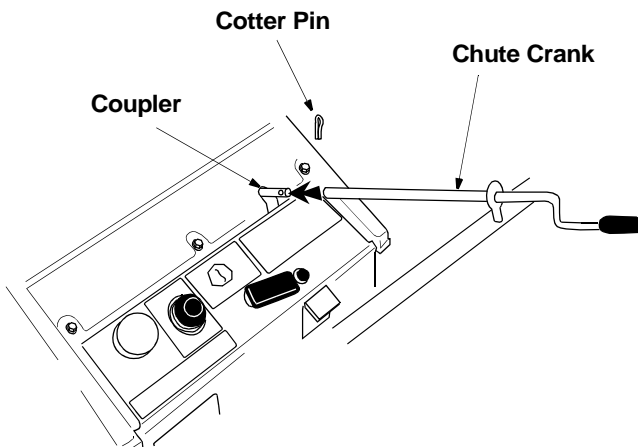

Figure 6

- Secure eyebolt with 5/16” saddle washer and hex nut. The cupped side of washer goes against the handle. Adjust lower hex nut until the eyebolt is positioned so that the chute crank turns freely (does not bind).
- Move upper hex nut down against the lower handle. Tighten lower hex nut securely.

Assembling Discharge Chute

The snow thrower has been shipped with the upper chute pivoted all the way down. Assemble as follows:

- Turn the chute crank until the chute faces straight to the front. See Figure 7.

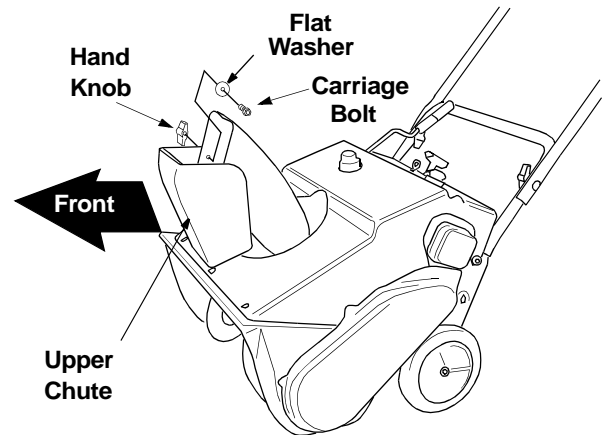

Figure 7

- Remove the hand knob, flat washer and carriage bolt from the upper chute. See Figure 7.
- Pivot the upper chute up so that there is no gap between the upper and the lower chute. See Figure 8. Secure with hardware just removed.

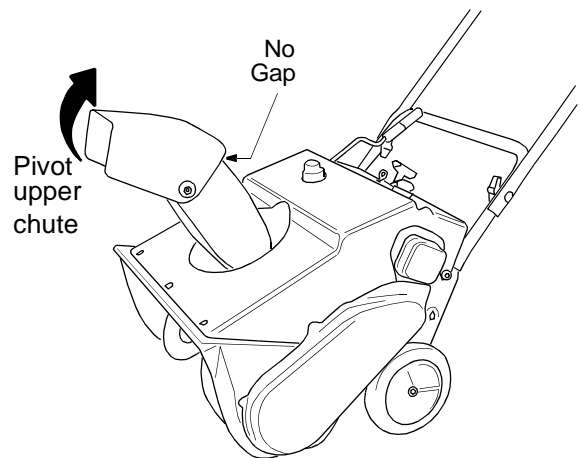

Figure 8

SECTION 3: KNOW YOUR SNOW THROWER



Be familiar with all the controls and their proper operation. Know how to stop the machine and disengage them quickly.

- Compare Figure 9 with the controls on your snow thrower before starting the machine or trying to operate it.

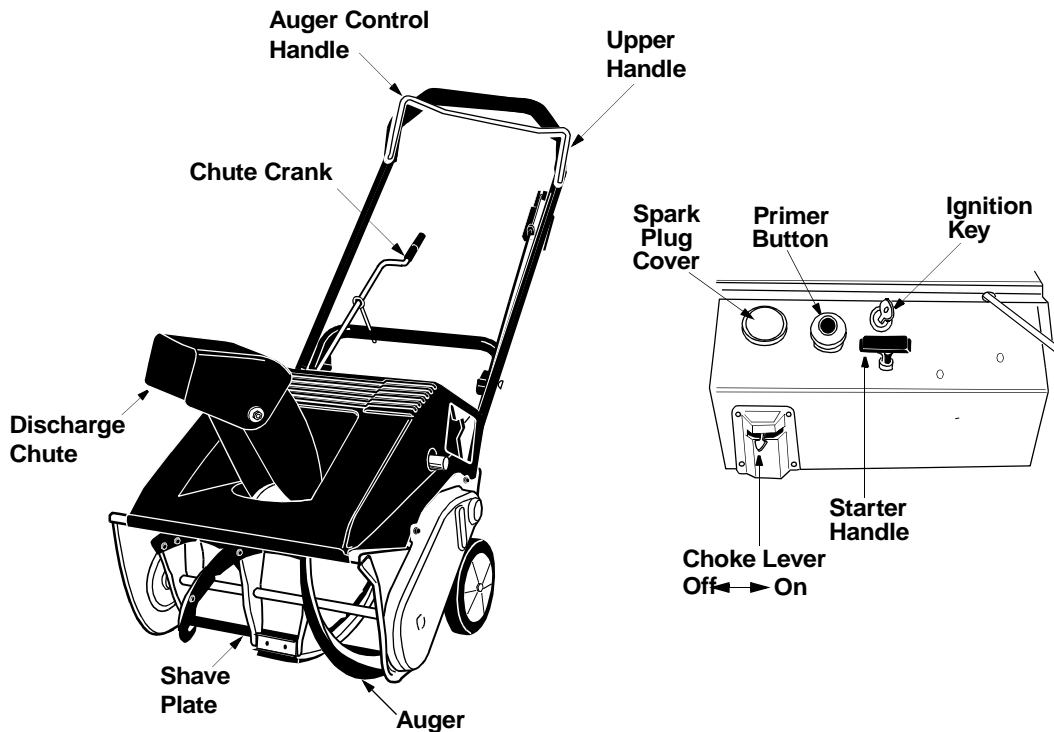

Figure 9

Choke Lever

Place choke lever in "ON" position to start a cold engine.

Primer Button

Used to inject fuel directly into the carburetor to insure fast starts in cold weather. Follow engine manual to prime engine.

Ignition Key

Used to start engine. Put key in "ON" position to start.

Starter Handle

Used to manually start the engine.

Spark Plug Cover

Spark plug located under the cover.

Auger Control Handle

Located on the upper handle, the auger control handle is used to engage and disengage the augers. The snow thrower is designed to be propelled by the rotation of the augers. Pull the control handle back against the

upper handle to engage the augers; release to disengage.

Chute Crank

Located on right side of dash panel, the chute crank determines the direction that snow will be discharged. Turn clockwise to discharge snow to the left; turn counterclockwise to discharge to the right.

Discharge Chute

The angle of the discharge chute controls the distance that the snow is thrown. Tilt the discharge chute up for greater distance; tilt down for less distance. Loosen the hand knob on the side of the discharge chute to adjust. Tilt the chute to the desired position, and tighten the knob.

Stopping Engine

- Turn ignition key to OFF position and remove it from the snow thrower.

SECTION 4: OPERATING YOUR SNOW THROWER

Before Starting



WARNING: Read, understand, and follow all instructions and warnings on the machine and in this manual before operating.

- The spark plug wire was disconnected for safety purposes during assembly. Attach spark plug wire to spark plug before starting.

Fuel & Oil Mixture



WARNING: Use extreme care when handling gasoline. Gasoline is extremely flammable and the vapors are explosive. Never fuel machine indoors or while the engine is hot or running. Extinguish cigarettes, cigars, pipes and other sources of ignition.

Your snow thrower uses a two cycle engine that requires a mixture of gasoline and two cycle engine oil. Refer to the engine operator's manual for proper oil and fuel recommendations.

- A plastic **cup** was provided inside the fuel fill opening on the fuel tank. Remove and discard this cup before filling up the tank. Use the separate fuel tank cap to close after fill-up.

Starting Engine

- To start the engine of your snow thrower, follow the engine manual.

Operating Snow Thrower

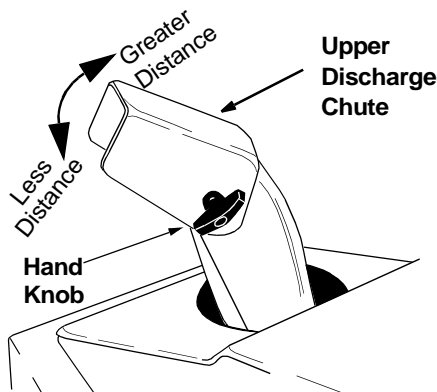

Figure 10

- Adjust the upper discharge chute up or down as shown in Figure 10. Then use the chute crank to position the discharge chute in order to discharge snow with the wind.

- After making sure no bystanders or obstacles are in front of the unit, engage the auger control handle. See Figure 11. As the snow thrower starts to move, maintain a firm hold on the handle, and guide the snow thrower along the path to be cleared.
- Release the auger control handle to stop the snow throwing action and the forward motion.

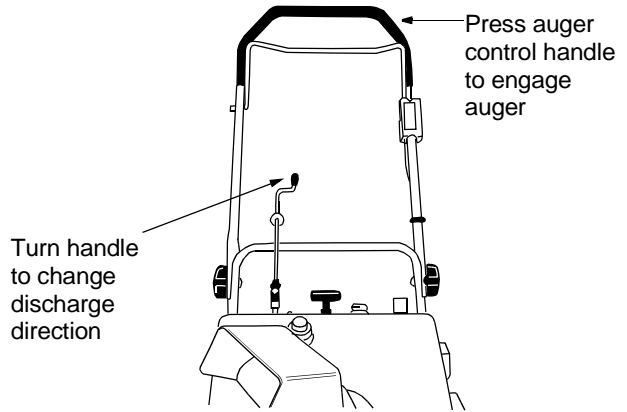

Figure 11

Stopping Engine

- Run the engine for a few minutes before stopping to help dry any moisture on the engine.
- To stop engine: Turn ignition key to OFF position and remove it from the snow thrower.

IMPORTANT: Keep the ignition key in a safe place. Engine will not start without it.

- Wipe all snow and moisture from the unit. Move the choke lever back and forth several times and leave it in the ON position.

Operating Tips

- Discharge snow downwind whenever possible. Slightly overlap each previously cleared path.
- Lifting up on the handle will allow the rubber on the augers to propel the snow thrower forward. Pushing downward on the handle will raise the augers off the ground and stop the forward motion.

NOTE: Excessive upward pressure on the handle will result in premature wear on the rubber auger blades which would not be covered by warranty.

- Run the engine for a few minutes before stopping to help dry any moisture on the engine.
- Clean the snow thrower thoroughly after each use.



WARNING: Muffler, engine and surrounding areas become hot and can cause a burn. Do not touch.

SECTION 5: MAKING ADJUSTMENTS



WARNING: NEVER attempt to make any adjustments while the engine is running, except where specified in the operator's manual.

Shave Plate

- To check the adjustment of the shave plate, place the unit on a level surface. See Figure 12. The wheels, shave plate and augers should all contact level surface. Note that if the shave plate is adjusted too high, snow may blow under the housing. If the shave plate wears out excessively, or the unit will not self-propel, the shave plate may be adjusted too low.

NOTE: On new units or units with a new shave plate installed, the augers may be slightly off the ground.

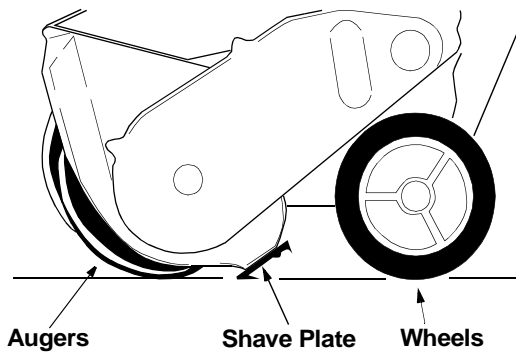

Figure 12

- To adjust, tip the snow thrower back so that it rests on the handle. Loosen the lock nuts and bolts which secure the shave plate to the housing. See Figure 13. Move the shave plate to desired position and retighten the nuts and bolts. Make certain all nuts and bolts are tightened securely.

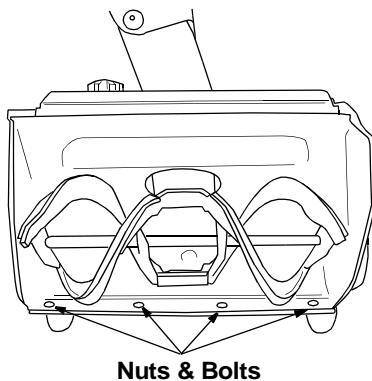

Figure 13

Belt Tension

Periodic adjustment of the belt tension may be required due to normal stretch and wear on the belt. If augers hesitate while turning although engine maintains same speed, adjust tension following instructions below.

- The upper hole in the control handle provides adjustment for belt tension. To adjust, disconnect the "Z" end of control cable from the bottom hole in the control handle. See Figure 14. Hook the cable into the upper hole in control handle as shown here.

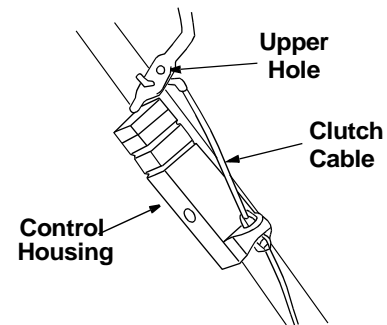

Figure 14

If additional adjustment is required, follow steps below.

- Remove the belt cover by removing five hex screws that hold it in place. See Figure 16.
- There are three adjustment holes provided in the idler bracket assembly. See Figure 15. To adjust, move the extension spring on the end of the clutch cable to the next higher adjustment position on the idler bracket assembly. Reassemble belt cover.

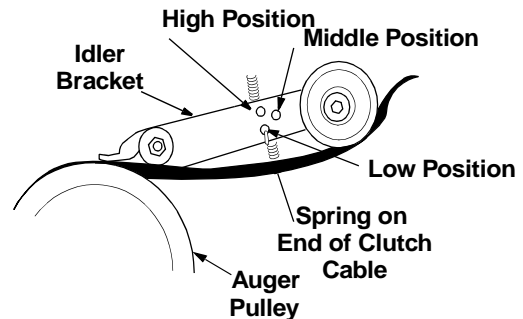

Figure 15

Carburetor



WARNING: If any adjustments need to be made to the engine while the engine is running (e.g. carburetor), keep clear of all moving parts. Be careful of muffler, engine and other surrounding heated surfaces.

- Refer to the separate engine manual, packed with your unit, for carburetor adjustment information.

SECTION 6: MAINTAINING YOUR SNOW THROWER



WARNING: Before servicing, repairing, or inspecting, disengage all clutch levers and stop engine. Wait until all moving parts have come to a complete stop. Disconnect spark plug wire and ground it against the engine to prevent unintended starting.

- Pull up on the idler pulley and slip the belt off the engine pulley.
- Push down on the idler pulley and slip the belt off the auger pulley.
- Reassemble new belt. See Figure 17.
- Reinstall the belt cover.

General Recommendations

- Always observe safety rules when performing any maintenance.
- All adjustments explained on page 9 should be checked at least once each season.
- Periodically check all fasteners and make sure these are tight
- Follow the maintenance schedule given below to get quality performance from your snow thrower for a long time.

Replacing Belt

- Remove the belt cover by removing five hex screws. See Figure 16.

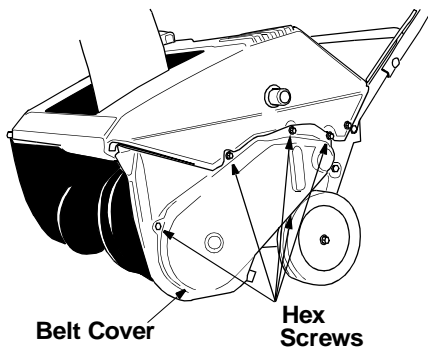

Figure 16

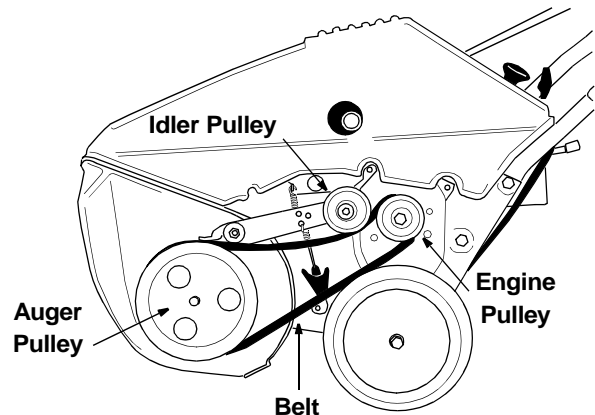

Figure 17

Replacing Shave Plate

The shave plate is subject to wear. It should be checked periodically. There are two wearing edges and the shave plate can be reversed. See Figure 13.

- Remove the four carriage bolts and hex lock nuts which attach it to the snow thrower housing.
- Install new shave plate, making sure the heads of the carriage bolts are on the inside of the housing.
- Adjust the shave plate according to procedure in the "Making Adjustments" section of this manual.
- Tighten securely.

Customer Responsibilities

MAINTENANCE SCHEDULE		Before each use	After each use	Every 25 hours	Once a season	Before storage	SERVICE DATES						
PRODUCT	Lubricate pivot points				✓	✓							
	Clean snow thrower		✓			✓							
	Check shave plate	✓											
	Check belt			✓									
ENGINE	Clean engine		✓										
	Check spark plug			✓	✓								

Lubrication

- Lubricate pivot points on the control handle and the extension spring at the end of the clutch cable with a light oil once every season and before storage of the snow thrower at the end of the season.

Engine

- Refer to the separate engine operator's manual packed with your snow thrower for all engine maintenance procedures.
- Check engine and snow thrower frequently for loose hardware, and tighten as needed.

SECTION 7: OFF-SEASON STORAGE



WARNING: Never store engine with fuel in tank indoors or in enclosed, poorly ventilated areas where fuel fumes may reach an open flame, spark or pilot light as on a furnace, water heater, clothes dryer, or other gas appliance.

- Clean snow thrower thoroughly.
- Lubricate as instructed above with a light oil.

- Follow "Storage" instructions in the Engine Manual.
- Store in a clean, dry area. Block the snow thrower up so it is not resting on the rubber auger blades.

NOTE: *When storing any type of power equipment in an poorly ventilated or metal storage shed, care should be taken to rustproof the equipment, especially springs, cables and all moving parts.*

SECTION 8: TROUBLESHOOTING GUIDE

Problem	Cause	Remedy
Engine fails to start	<ol style="list-style-type: none"> 1. Fuel tank empty, or stale fuel 2. Blocked fuel line 3. Key not in ON position 4. Spark plug wire disconnected 5. Faulty spark plug 6. Gasoline and oil not mixed correctly 	<ol style="list-style-type: none"> 1. Fill tank with clean fresh gasoline/oil mixture as specified in the engine manual. 2. Clean fuel line 3. Insert key and turn to ON position 4. Connect wire to spark plug. 5. Clean spark plug, readjust gap, or replace. 6. Refer to engine manual
Engine runs erratic	<ol style="list-style-type: none"> 1. Unit running on choke 2. Fuel line blocked, or stale fuel 3. Water or dirt in fuel system 4. Carburetor out of adjustment 	<ol style="list-style-type: none"> 1. Move choke lever to off position. 2. Clean fuel line and fill tank with fresh, clean gasoline. 3. Refer to engine manual on remedy. 4. Refer to engine manual.
Engine overheats	<ol style="list-style-type: none"> 1. Gasoline and oil not mixed correctly 2. Carburetor out of adjustment 	<ol style="list-style-type: none"> 1. Drain fuel tank and refill with proper fuel mixture. 2. Refer to engine manual.
Loss of power	<ol style="list-style-type: none"> 1. Spark plug wire loose 2. Vent in gas cap plugged 3. Exhaust port plugged. 	<ol style="list-style-type: none"> 1. Connect and tighten spark plug wire. 2. Clear vent. 3. Clean port.
Excessive vibration	<ol style="list-style-type: none"> 1. Loose parts or damaged auger 	<ol style="list-style-type: none"> 1. Stop engine immediately and disconnect spark plug wire. Check for possible damage. Tighten all bolts and nuts. Repair as needed. If the problem persists, take unit to an authorized service dealer.
Unit fails to self-propel	<ol style="list-style-type: none"> 1. Drive cable out of adjustment 2. Drive belt loose or damaged 	<ol style="list-style-type: none"> 1. Adjust drive cable following instructions on snow thrower. 2. Replace drive cable following instructions on snow thrower.
Unit fails to discharge snow	<ol style="list-style-type: none"> 1. Discharge chute clogged 2. Foreign object lodged in auger 3. Drive cable not adjusted properly 4. Drive belt loose or damaged 	<ol style="list-style-type: none"> 1. Stop engine immediately and disconnect spark plug wire. Clean discharge chute and the auger housing. 2. Stop engine immediately and disconnect spark plug wire. Remove object . 3. Adjust drive cable following instructions on snow thrower. 4. Replace drive belt following instructions on snow thrower.

NOTE: For repairs beyond the minor adjustments listed above, call the Customer Dealer Line at 1-800-528-1009 for the dealer nearest you. Refer to separate engine manual, packed with your snow thrower, for engine information.

SECTION 9: PARTS LIST FOR MODEL 421R

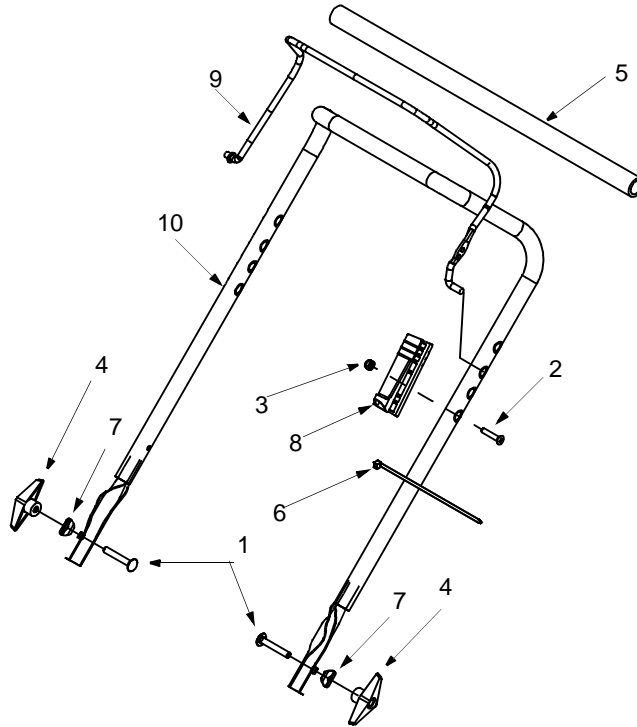

Ref. No.	Part No.	Description
1.	710-0487	Carriage Screw
2.	710-1270	Oval C-Sunk Machine Screw
3.	712-0324	Hex Lock Nut
4.	720-0284	Wing Nut
5.	720-0295	Foam Grip: Handle
6.	725-0157	Cable Tie
7.	736-0451	Saddle Washer
8.	746-0883	Cable Housing w/o Throttle
9.	747-0956	Auger Bail: Gull Wing
10.	749-0711A	Upper Handle: Gull Wing

NOTE: For **painted parts**, please refer to the list of color codes below. Please add the applicable color code, wherever needed, to the part number to order a replacement part. For instance, if a part, numbered 700-xxxx, is painted Cub Yellow, the part number to order would be 700-xxxx-0716.

Cub Yellow: 0716

Cub Beige: 0499

Cub Blue: 0685

Powder Black: 0637

SECTION 10: Model 421R

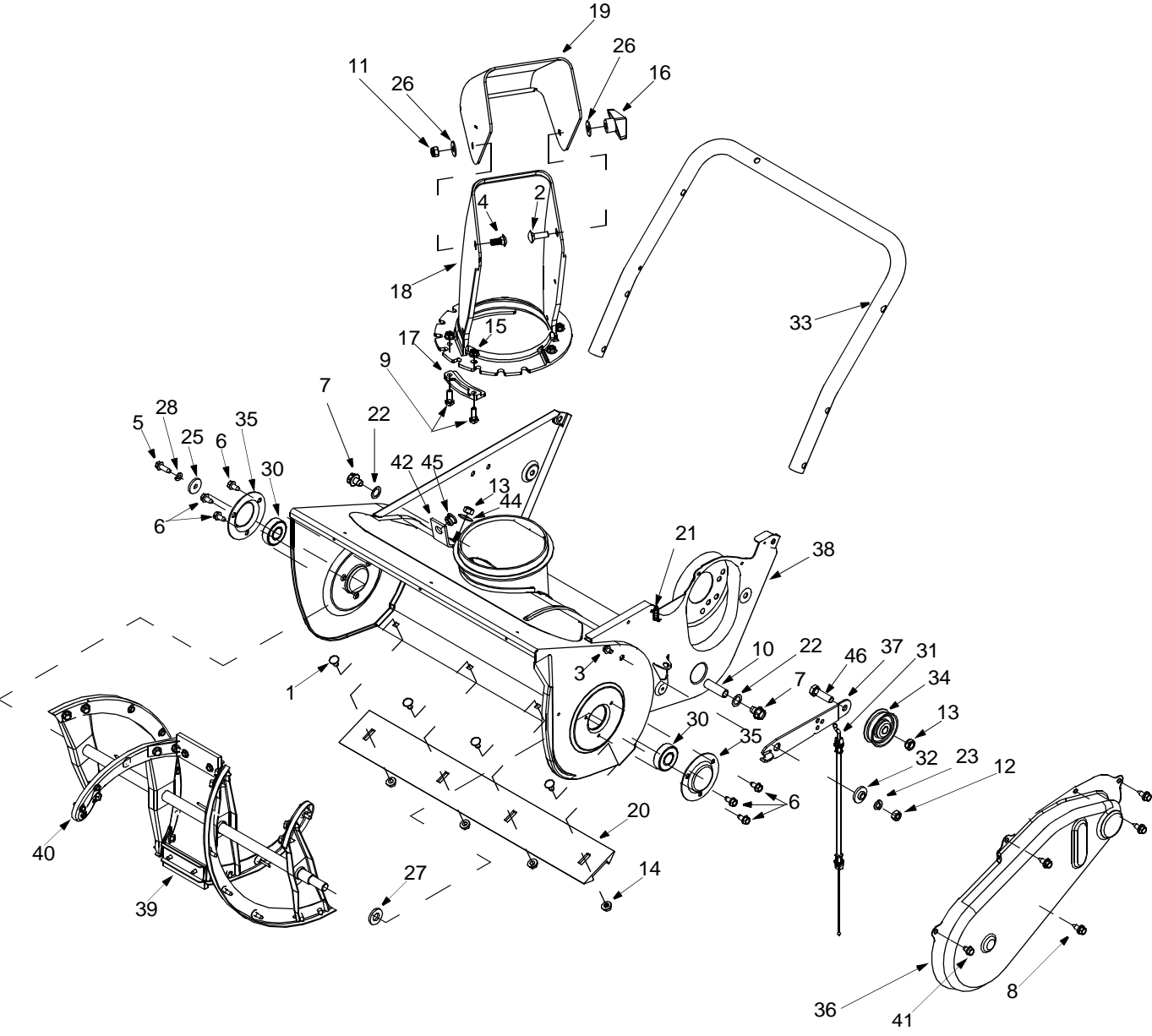

Model 421R

Ref. No.	Part No.	Part Description	Ref. No.	Part No.	Part Description
1.	710-0167	Carriage Bolt	25.	736-0176	Flat Washer
2.	710-0276	Carriage Bolt	26.	736-0159	Washer
3.	710-0323	Pan Head Screw	27.	736-0326	Flat Washer
4.	710-0451	Carriage Bolt	28.	736-0329	Lock Washer
5.	710-0642	Hex Washer Screw	30.	741-0600	Ball Bearing
6.	710-1005	Hex Washer Screw	31.	746-0910A	Cable—Clutch
7.	710-0773	Hex Washer Screw	32.	748-0234	Spacer
8.	710-0896	Hex Washer Screw	33.	749-0796	Handle—Lower
9.	710-3015	Hex Cap Screw	34.	756-0313	Flat Idler
10.	711-0848A	Axle	35.	784-5174	Bearing Cup
11.	712-0429	Hex Center Lock Nut	36.	784-5176	Cover—Belt
12.	712-3010	Hex Nut	37.	784-5175B	Idler/Brake Bracket
13.	712-0116	Hex Lock Nut	38.	684-0114	Blower Housing
15.	712-3027	Hex Lock Flanged Nut	39.	784-5485	Auger Ass'y. Comp.
16.	720-0284	Knob	40.	753-0613	Auger Rubber Replacement
17.	731-0851A	Chute Keeper	41.	710-0352	Hex Washer Screw
18.	731-0915B	Lower Chute	42.	784-5720	Crank Bracket
19.	731-0921	Upper Chute	43.	710-0451	Cap Screw
20.	731-1033	Shave Plate	44.	736-0242	Bell Washer
21.	732-0357A	Extension Spring	45.	741-0475	Bushing
22.	736-0108	Flat Washer	46.	710-0191	Hex Screw
23.	736-0119	Lock Washer			

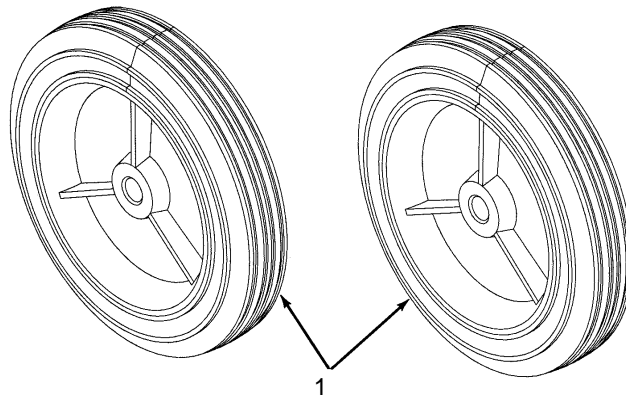

Ref. No.	Part No.	Description
1	734-1811	Wheel Assembly: 7 x 1.7"

NOTE: For **painted parts**, please refer to the list of color codes below. Please add the applicable color code, wherever needed, to the part number to order a replacement part. For instance, if a part, numbered 700-xxxx, is painted Cub Yellow, the part number to order would be 700-xxxx-0716.

Cub Yellow: 0716
 Cub Beige: 0499
 Cub Blue: 0685
 Powder Black: 0637

Model 421R

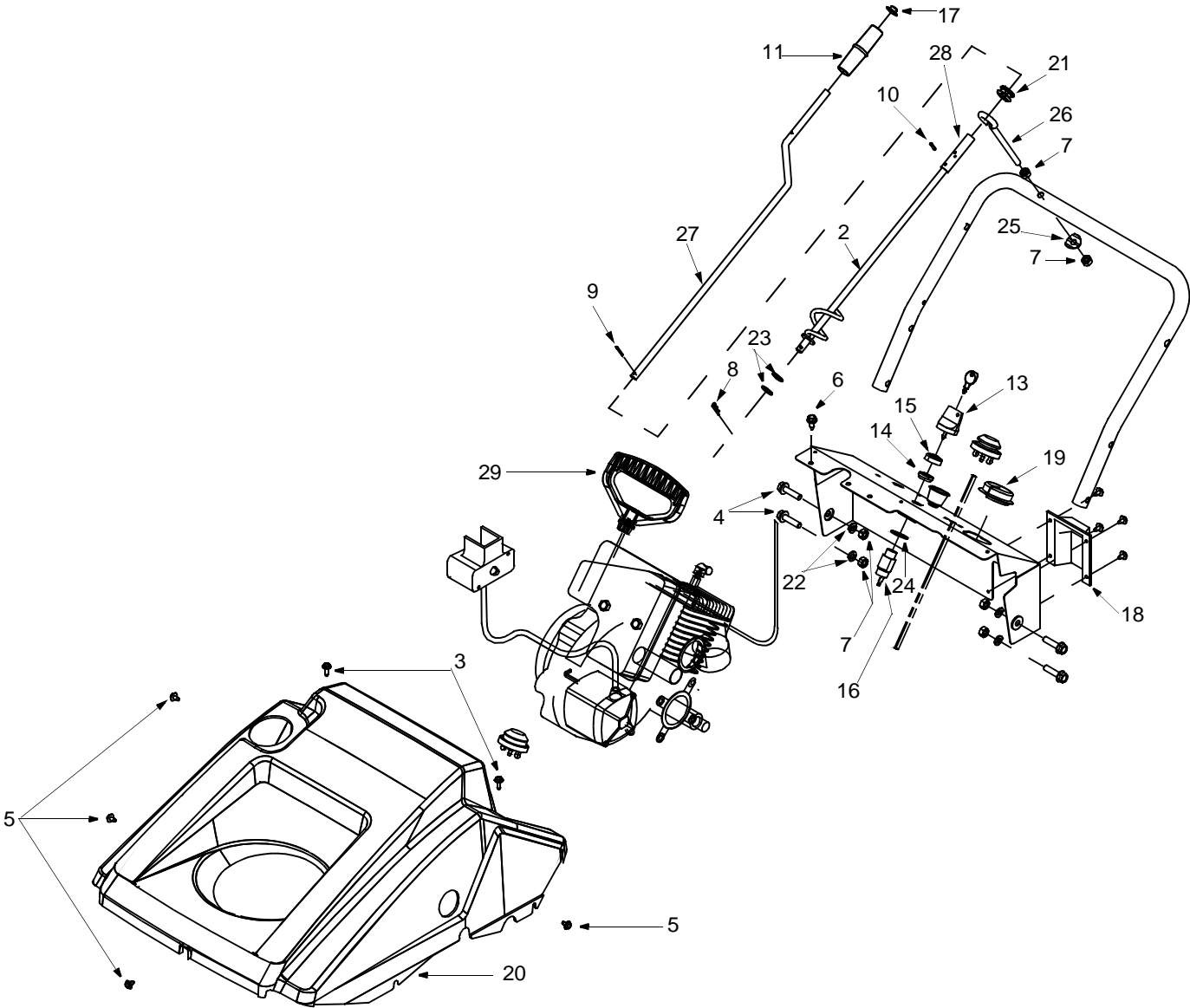

Model 421R

Ref. No.	Part No.	Part Description
1.	684-0054A	Dash Assembly
2.	684-0126	Chute Crank Assembly
3.	710-1003	Special Screw: 310-16 x 0.375"
4.	710-1090	Hex Flange Screw 5/16-18 x 1.25"
5.	710-1268	Special screw
6.	710-1652	Self-Tapping Screw 1/4-20 x .625"
7.	712-3010	Hex Nut 5/16-18
8.	714-0104	Hairpin Clip
9.	714-0507	Cotter Pin
10.	715-0138	Roll Pin
11.	720-0201A	Chute Crank Knob
12.	725-0201	Ignition Key
13.	725-1341B	Ignition Key w/o Logo
14.	725-1346	Ignition Switch Nut
15.	725-1347	Ignition Switch Cap
16.	725-1425	Switch: Key, Recoil Start
17.	726-0100	Push Cap
18.	731-1089A	Choke Cover
19.	731-1133B	Spilling Cup
20.	731-2109	Shroud: 21" Beige
21.	735-0234	Rubber Grommet
22.	736-0119	Lock Washer
23.	736-0185	Flat Washer
24.	736-0225	Internal Lock Washer
25.	736-0451	Saddle Washer
26.	747-0697	Eyebolt
27.	747-0737	Upper Chute Crank
28.	750-0785	Spacer
29.	7510009636	Mitten Grip Handle

NOTE: For **painted parts**, please refer to the list of color codes below. Please add the applicable color code, wherever needed, to the part number to order a replacement part. For instance, if a part, numbered 700-xxxx, is painted Cub Yellow, the part number to order would be 700-xxxx-0716.

Cub Yellow: 0716

Cub Beige: 0499

Cub Blue: 0685

Powder Black: 0637

Model 421R

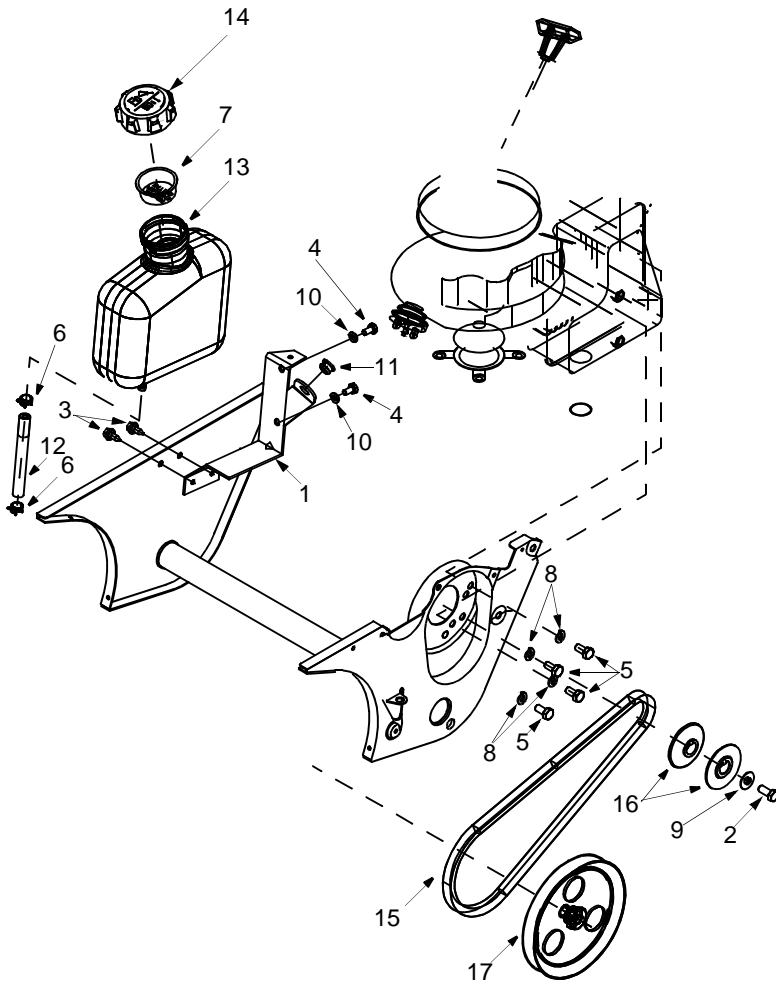

Ref. No	Part No.	Description
1.	705-5139A	Support Bracket: Gas Tank
2.	710-0157	Hex Bolt 5/16-24 x .75"
3.	710-1652	Self-Tapping Screw
4.	710-3013	Hex Screw 1/4-20 x .50"
5.	710-3025	Hex Screw
6.	726-0205	Hose Clamp
7.	731-2113A	Cup
8.	736-0119	Lock Washer
9.	736-0242	Beleville Washer
10.	736-0329	Lock Washer
11.	741-0475	Plastic Bushing
12.	751-0535	Fuel Line Hose
13.	751-0540A	Fuel Tank: 2 Quart
14.	751-0800	Fuel Cap
15.	754-0101A	V-Belt
16.	756-0416B	V-Pulley Half
17.	756-0475	V-Pulley Half

NOTE: For **painted parts**, please refer to the list of color codes below. Please add the applicable color code, wherever needed, to the part number to order a replacement part. For instance, if a part, numbered 700-xxxx, is painted Cub Yellow, the part number to order would be 700-xxxx-0716.

Cub Yellow: 0716
 Cub Beige: 0499
 Cub Blue: 0685
 Powder Black: 0637

Model 421R

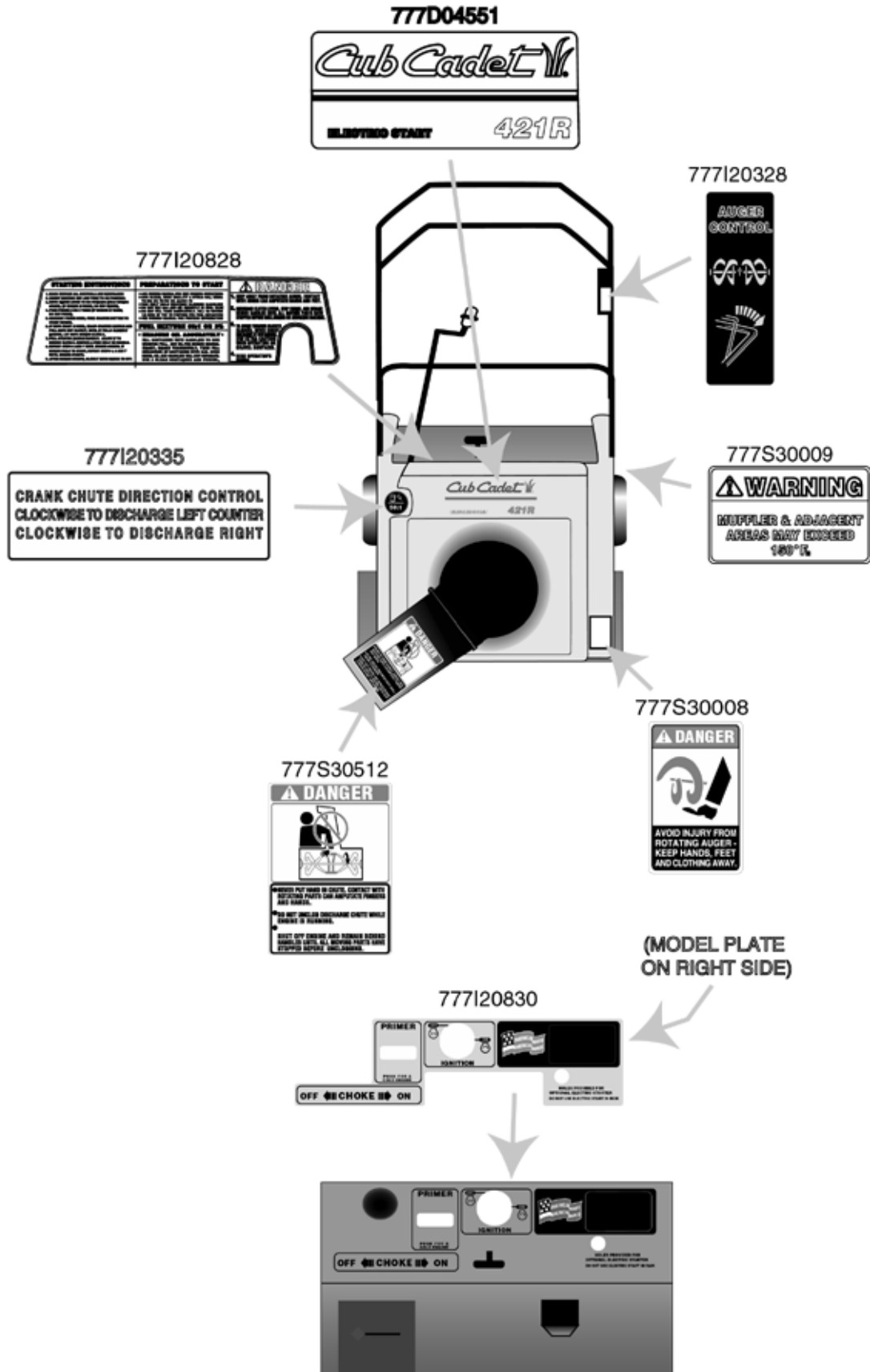

MANUFACTURER'S LIMITED WARRANTY FOR:



TWO-YEAR RESIDENTIAL ONE-YEAR COMMERCIAL

Proper maintenance of your Cub Cadet equipment is the owner's responsibility. Follow the instructions in your operator's manual for correct lubricants and maintenance schedule. Your Cub Cadet dealer carries a complete line of quality lubricants and filters for your equipment's engine, transmission, chassis and attachments.

Riding mowers, lawn tractors, garden tractors, Cub Cadet attachments and home maintenance products

This limited warranty for residential users, covers any defect in materials or workmanship in your Cub Cadet equipment for two years from the date of purchase for the first user purchaser. We will replace or repair any part or parts without charge through your authorized Cub Cadet dealer.

Batteries have a one-year prorated limited warranty with 100% replacement during the first three months.

V-belts for either the traction drive or any attachments are covered for one year only.

Cub Cadet equipment used commercially is warranted for one year only.

(Commercial use is defined as either having hired operators or used for income producing purposes.)

Items not covered

The warranty does not cover routine maintenance items such as lubricants, filters (oil, fuel, air and hydraulic), cleaning, tune-ups, brake and/or clutch inspection, adjustments made as part of normal maintenance, blade sharpening, set-up, abuse, accidents and normal wear. It does not cover incidental costs such as transporting your equipment to and from the dealer, telephone charges or renting a product temporarily to replace a warranted product.

There is no other express warranty.

How to obtain service

Contact your authorized Cub Cadet servicing dealer who sold you your Cub Cadet equipment. If this dealer is not available, see the Consumer Yellow Pages under "lawn mowers" for the name of a dealer near you.

If you need further assistance in finding an authorized Cub Cadet servicing dealer, contact:

**Cub Cadet Corporation
Post Office Box 368023
Cleveland, Ohio 44136**

How does state law apply?

This limited warranty gives you specific legal rights, and you may also have other rights which vary from state to state.