

**Creda**

# Europa S230G

## Use and Installation Instructions

**Note:** Timer must be set to 'Time of Day' and 'Manual' before the ovens can be used.

**Note:** Ensure that the oven is securely fixed to the cabinet before use.

**This appliance shall be installed in accordance with the regulations in force and only used in a well ventilated space.**

***Read the instructions before installing or using the appliance and retain them for future use***



For more information on our exciting product range ring  
**Creda Answer Centre 08701 54 64 74**

OR



Visit us on the **NET** at  
**<http://www.creda.co.uk>**

Our site invites you to make use of our **interactive cookbook** and **product selector**. Feel free to **browse our product range** to see what's **bubbling away** at the moment or to **ask for help** on our products and services



**Creda**

**Merloni Elettrodomestici UK Ltd.** Morley Way Peterborough PE2 9JB  
**Creda Answer Centre** 08701 54 64 74  
**Web** <http://www.creda.co.uk>

It may be necessary from time to time to change the specification outlined in this booklet without notice. Any change which is made will not affect your statutory rights.

# CONTENTS

Introduction	4
For Your Safety – Always	5
For Your Safety – Never	6
Oven Timer Operation	7
Know Your Timer	8
Electronic Clock & Automatic Oven Timer Operation	9-12
Grill Pan and Handle	13
Using The Grill	14
Using the Top Oven	15
Using the Main Oven	18
Care and Cleaning	23
Installation	26
Something Wrong?	33
Key Contacts	Back Cover

## **DISPOSAL OF YOUR PRODUCT**

To minimise the risk of injury to children please dispose of your product carefully and safely. Remove all doors and lids (where fitted). Remove the mains cable (where fitted) by cutting off flush with the appliance and always ensure that no plug is left in a condition where it could be connected to the electricity supply.

To help the environment, Local Authority instructions should be followed for the disposal of your product.

# INTRODUCTION

Your new cooker is guaranteed\* and will give lasting service. This guarantee is only applicable if the appliance has been installed in accordance with the installation instructions detailed in this booklet.

To help make best use of your cooking equipment, please read this booklet carefully.

The cooker is designed specifically for domestic use and responsibility will not be accepted for use in any other installation.

When first using the cooker ensure that the room is well ventilated (e.g. open a window or use an extractor fan) and that persons who may be sensitive to the odour avoid any fumes. It is suggested that any pets be removed from the room until the smell has ceased. This odour is due to any temporary finish and also any moisture absorbed by the insulation.

**\* The guarantee is subject to the provisions that the appliance:**

- (a) Has been used solely in accordance with the Users Instruction Book.**
- (b) Has been properly connected to a suitable supply voltage and gas supply as stated on the Data badge attached to this equipment.**
- (c) Has not been subjected to misuse or accident or has not been modified or repaired by any person other than the authorised employee or agent.**
- (d) Has been correctly installed.**

This appliance conforms to the following EEC Directives:



Low Voltage Equipment  
73/23/EEC  
93/68/EEC

Gas Appliances  
90/396/EEC

Electromagnetic Compatibility  
89/336/EEC  
92/31/EEC  
93/68/EEC

# FOR YOUR SAFETY



**When used properly, your appliance is completely safe but as with any product there are certain precautions that must be observed.**

**PLEASE READ THE PRECAUTIONS BELOW BEFORE USING YOUR APPLIANCE.**

## **ALWAYS**

- Always make sure you remove all packaging and literature from inside the oven and grill compartments before switching on for the first time.
- Always make sure you understand the controls prior to using the appliance.
- Always keep children away from the appliance when in use as the surfaces will get extremely hot during and after cooking.
- Always make sure all controls are turned off when you have finished cooking and when not in use.
- Always stand back when opening an oven door to allow any build up of steam or heat to disperse.
- Always use dry, good quality oven gloves when removing items from the oven/grill.
- Always take care to avoid heat/steam burns when operating the controls.
- Always turn off the electricity supply at the wall switch before cleaning and allow the appliance to cool.
- Always make sure the shelves are in the correct position before switching on the oven.
- Always keep the oven and grill doors closed when the appliance is not in use.
- Always take care when removing utensils from the top oven when the main oven is in use as the contents may be hot.
- Always keep the appliance clean as a build up of grease or fat from cooking can cause a fire.
- Always follow the basic principles of food handling and hygiene to prevent the possibility of bacterial growth.
- Always keep ventilation slots clear of obstructions.
- Always refer servicing to a CORGI registered service engineer.

# FOR YOUR SAFETY



## NEVER

- Never leave children unsupervised where a cooking appliance is installed as all cooking surfaces will be hot during and after use.
- Never allow anyone to sit or stand on any part of the appliance.
- Never store items above the appliance that children may attempt to reach.
- Never remove the oven shelves whilst the oven is hot.
- Never heat up unopened food containers as pressure can build up causing the container to burst.
- Never store chemicals, food stuffs or pressurised containers in or on the appliance, or in cabinets immediately above or next to the appliance.
- Never use the appliance as a room heater.
- Never use the grill to warm plates.
- Never dry any items on the oven doors.
- Never allow children to play with the controls.

**NOTE: The use of a gas cooking appliance results in the production of heat and moisture in the room in which it is installed. Ensure that the kitchen is well ventilated; keep natural ventilation holes open or install a mechanical ventilation device (mechanical extractor hood).**

**Prolonged intensive use of the appliance may call for additional ventilation, for example opening of a window, or more effective ventilation, for example increasing the level of mechanical ventilation where present.**

# OVEN TIMER OPERATION

**Note: Timer must be set to 'Time of Day' and 'Manual' before the ovens can be used.**

## AUTOMATIC COOKING

The Top Oven and Main Oven can be controlled by the automatic timer. When the timer control has been set for one oven, it is possible to use the other oven only during the same automatic cooking programme.

## HINTS ON AUTOMATIC COOKING

1. Select foods which will require the same cooking time and temperature.
2. To ensure food does not cool down and require reheating, set the end time so the food is ready when you require it.
3. Always ensure that meat and poultry is defrosted before placing in the oven.
4. Whenever possible, take food out of the refrigerator and keep it as cool as possible.
5. If cooking food that requires frying before placing in the oven for auto cooking, keep the delay start time to a minimum.
6. Never place hot or warm food in the oven for delay start cooking as it could cause the oven to be warm and produce harmful bacteria in the food.
7. We advise that dishes containing left-over cooked poultry or meat, e.g. Shepherd's Pie, should not be cooked automatically if there is to be a delay period.
8. Ensure that delay start times are kept to a minimum to prevent bacterial growth in food.
9. Wine or beer may ferment and cream may curdle during the delay period so it is best to add these ingredients just before serving.
10. Foods which discolour should be protected by coating in fat or tossing in water to which lemon juice has been added, prior to placing food in the oven.
11. Dishes containing liquid should not be filled too full to prevent boiling over.
12. Food should be well sealed (but not airtight) in a container to prevent the loss of liquid during cooking. Aluminium foil gives a good seal.
13. Always ensure that food is piping hot and cooked thoroughly before serving.
14. Only reheat food once.

# KNOW YOUR TIMER

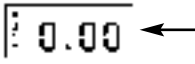
**CLOCKFACE**  

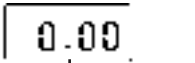
 The timer incorporates a 24 hour clock.  
**Ensure the correct time of day is always set, before using your cooker.**

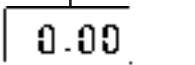
**SYMBOLS**  

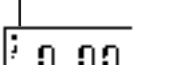
 A 'bell' symbol will light up when you select a Minute Minder Period and will remain lit for the period set.  
 At the end of the Minute Minder Period, the timer will emit an audible tone and the 'bell' symbol will disappear.



 The 'cookpot' symbol will light up either:-  
 - When the timer is in manual mode, or  
 - During the actual Cook Period.



 The 'AUTO' symbol will flash at the end of an Auto Cooking programme to indicate that the programme has finished.  
**(When the 'AUTO' symbol is flashing, to return the oven to Manual operation, turn the oven controls off, ensure that the correct time of day is set, and press the "Manual" button – The 'AUTO' symbol will go out).**

## TIMER FUNCTION BUTTONS

 **Minute Minder Button** Here you can set a time period of up to 23 hours 59 minutes, that will count down. When it reaches zero, the timer will emit an audible tone.  
**For Example:** If you set 20 minutes, the audible tone will occur 20 minutes later.

## AUTO COOKING PROGRAMME

 **Cook Period Button** Cook Period is the actual length of time for which, the timer will switch the oven(s) on as part of an "Auto Cooking" programme.  
 (e.g. If you set 2 hours, the food will be cooked for 2 hours).

 **End Time Button** The time of day at which you want an "Auto Cooking" programme to **end**.  
**For Example:** If you set a "Cook Period" for 2 hours, and "End Time" of 11:00. The timer will switch the oven(s) on at 9:00 and turn the oven(s) off at 11:00. You will hear a audible tone at 11:00, to indicate that the Auto Cooking Programme has finished.

**Notes:**

- When setting an Auto Cooking programme you will need to set the oven control(s) to the required temperature(s) when you set the timer.
- If an Auto Cooking programme has been set the oven(s) will only operate during the pre-programmed time.

 **Manual Button** Needs to be pressed to cancel an Auto Cooking programme and return the oven(s) to Manual operation.

**"+" and "-" Buttons** Used to adjust the various timer function settings.



# ELECTRONIC CLOCK & AUTOMATIC OVEN TIMER OPERATION

## SETTING THE TIME OF DAY

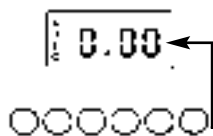

**Step 1** Make sure all oven controls are turned Off.

**Step 2** Check the electricity supply to the cooker is turned on.

**Step 3** When switched on the display will show 0.00 and the Auto symbol, flashing intermittently.

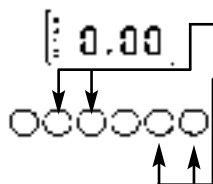

**Step 4** Press & hold in both the Cook Period & End Time buttons together.

**Step 5** With the Cook Period & End Time buttons still held in, press either the "+" or "-" buttons to set the correct time of day.

**Step 6** Release all the buttons simultaneously.

**THE TIME OF DAY IS NOW SET.**

*To change the time of day repeat Steps 4, 5 & 6 above.*

**Note:** You cannot adjust the time of day if the timer has been set for an Auto Cooking Programme.

## SETTING THE MINUTE MINDER

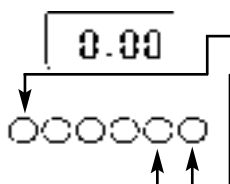

**Step 1** Ensure the time of day is set correctly.

**Step 2** Press and hold the Minute Minder button.

**Step 3** With the Minute Minder button held in, set the required Minute Minder period using the "+" and "-" buttons. A 'bell' symbol will light up.

Release all buttons and the timer display will revert back to the time of day. The 'bell' symbol will remain lit to signify that a Minute Minder period has been set.

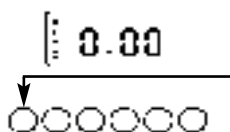

At the end of the set time an audible tone will be heard, and the 'bell' symbol will disappear.

**Step 4** To cancel the audible tone press the Minute Minder button.

**Note 1** When the Minute Minder has been set, the time remaining can be checked at any time by simply pressing the Minute Minder button.

**Note 2** If necessary the Minute Minder can be cancelled before the tone sounds by pressing and holding the Minute Minder button and then at the same time pressing the "-" button until 0.00 appears in the display window.

# ELECTRONIC CLOCK & AUTOMATIC OVEN TIMER OPERATION

## AUTO COOKING PROGRAMMES

There are two Auto Cooking programmes that can be selected using your timer:-

- (a) To set the timer to switch the oven(s) On and Off Automatically
- (b) To set timer to switch on immediately and OFF automatically after a set cook period.

### a) TO SET THE TIMER TO SWITCH THE OVEN(S) ON AND OFF AUTOMATICALLY

*This allows you to cook at a specified time for a chosen period before the oven switches off Automatically.*

- Step 1** Check that the correct time of day is set, if not follow instructions for setting the time of day.  
**Step 2** Place food onto the correct shelf position in the oven and close the oven door(s).

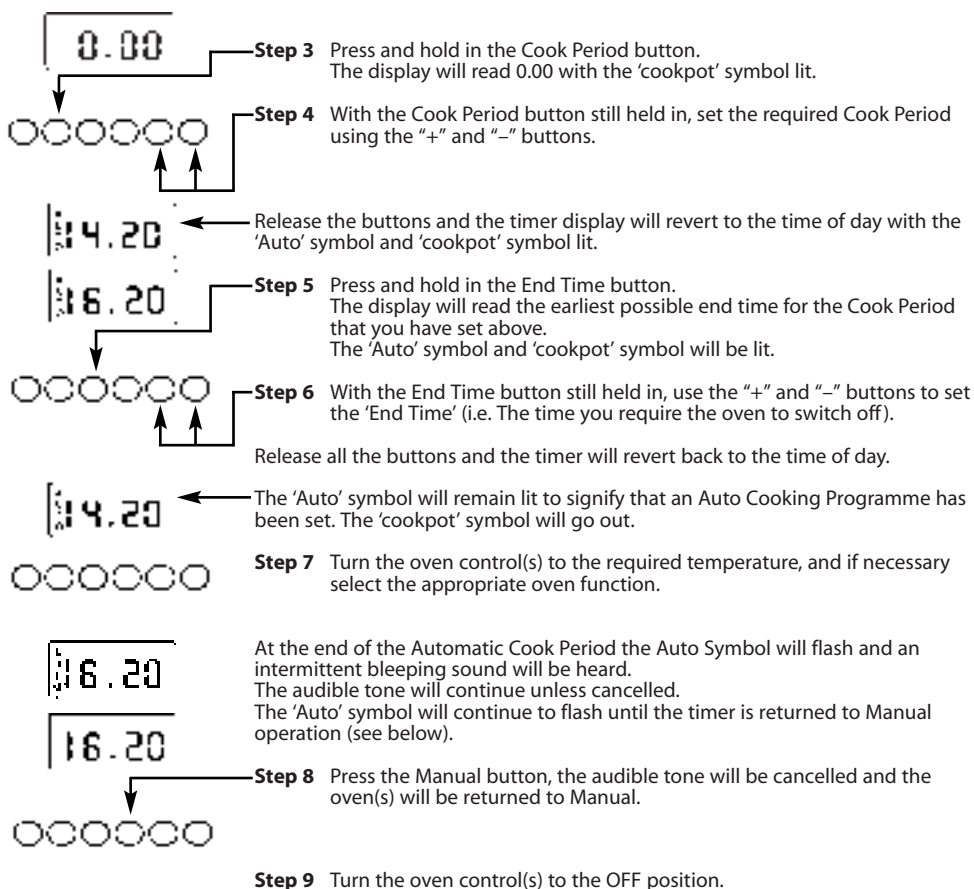

# ELECTRONIC CLOCK & AUTOMATIC OVEN TIMER OPERATION

**Note 1** When cooking automatically the Cook Period can be checked at any time by simply pressing the Cook Period button.

**Note 2** When cooking automatically the End Time can be checked at any time by simply pressing the End Time button.

## b) TO SET TIMER TO SWITCH ON IMMEDIATELY AND OFF AUTOMATICALLY AFTER A SET COOK PERIOD

- Step 1** Check that the correct time of day is set, if not follow instructions for setting the time of day.  
**Step 2** Place food onto the correct shelf position in the oven and close the oven door(s).  
**Step 3** Turn the oven control(s) to the required temperature, and if necessary select the appropriate oven function.

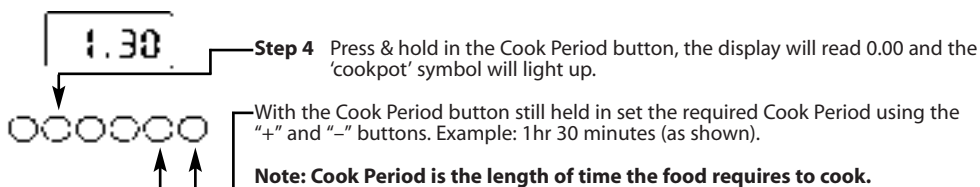

**Step 5** Release all buttons.

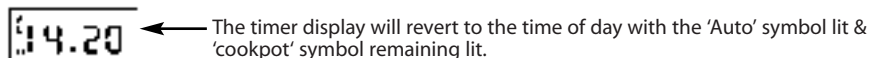

NOTE: The Cookpot symbol disappears

At the end of the Cook Period the 'Auto' symbol will flash and an intermittent audible tone will be heard. The audible tone will continue until cancelled. The 'Auto' symbol will continue to flash until the timer is returned to Manual operation (see below).

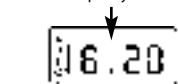

**Step 6** Press the Manual button. The audible tone will be cancelled and the oven(s) will be returned to Manual.

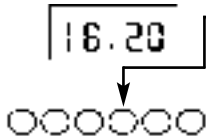

**Step 7** Turn the oven control(s) to the OFF position.

# ELECTRONIC CLOCK & AUTOMATIC OVEN TIMER OPERATION

## TO CANCEL AN AUTO COOKING PROGRAMME BEFORE THE COOK PERIOD HAS FINISHED.

**Step 1** Turn the oven control(s) to the OFF position.

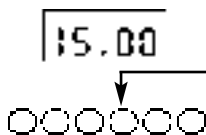

**Step 2** Press the Manual button to return the oven(s) to "Manual" operation. The 'Auto' symbol will go out.

**Note 1** When cooking automatically the Cook Period can be checked at any time by simply pressing the Cook Period button.

## OTHER NOTES ON TIMER OPERATION

1. When cooking Automatically the Cook Period can be checked at any time simply by pressing the Cook Period button.
2. When cooking Automatically the End Time can be checked at any time by simply pressing the End Time button.
3. Having set a Cook Period and End Time an electronic device stores the information. The device within the timer will switch the oven(s) on and off at the required times.
4. When setting an Auto Cooking Programme and a mistake is made, to clear:-
  - (a) Press & release the Manual button.
  - (b) Start the sequence again.
5. If at any time the display shows three flashing zero's 0.00 and 'Auto', it is likely that the electricity supply to the oven has been interrupted. Reset the timer to the correct time of day.  
**Food in the oven may, therefore, not have been cooked, before serving check food is thoroughly heated and completely cooked.**
6. To set each function always press and hold the required function button and at the same time press "+" or "-" buttons.

# GRILL PAN & HANDLE

The grill pan handle is detachable from the pan, to facilitate cleaning and storage. The grill pan handle can be fixed as follows:



**Step 1** Remove screw & washers from the grill pan bracket.

**Step 2** Tilt the handle over the recess (a).

**Step 3** Slide it towards the centre of the pan (b).

**Step 4** Locate the handle over the bracket (c).

For a fixed handle, replace screw & washers and ensure they are fully tightened up. If a detachable handle is required, do not replace screw & washers.

**NOTE: Ensure that when using the grill pan handle in the detachable manner it is centralised and secure.**

**The grill pan can be stored in the top compartment with the handle attached by placing the shelf in the middle or lower position and tilting the grill pan over the rear edge of the shelf.**

# USING THE GRILL

**CAUTION - ACCESSIBLE PARTS MAY BECOME HOT WHEN THE GRILL IS USED. YOUNG CHILDREN SHOULD BE KEPT AWAY.**

- Step 1** Open the top oven door and remove the grill pan.
- Step 2** Place the shelf in the chosen position.
- Step 3** Push in and turn the control knob clockwise to the large flame symbol. Sparking will continue until the grill burner is lit.
- Step 4** Slide the grill pan along the shelf towards the rear of the compartment until it stops.
- Step 5** Turn the control knob clockwise to the desired setting. Only turn the control between the large and the small flame symbols.
- Step 6** To turn off, turn the control knob anti-clockwise to the symbol **O**.

**Note: DO NOT line the grill pan with aluminium foil, as this increases the amount of fat spitting and can cause a fire.**

**The grill burner will only operate when the door is open. If the grill door is closed while the grill is on, the grill burner will be shut off. When the door opened again the grill burner will turn on and be reignited.**

Grilling can be started from cold but for best results preheat for approximately two minutes. Most cooking is done with the heat on full, but it may be desirable to reduce it for thicker pieces of meat or for keeping food warm.

For au gratin dishes e.g. macaroni cheese and meringue toppings e.g. baked alaska, place the dish on the floor of the grill compartment. The base of the grill pan can be used for warming fruit garnishes on the reduced setting.

## COOLING FAN

A gentle flow of air will be blown below the control panel when any control is used.

Whenever the appliance has been used, the cooling fan may continue to run or restart itself after all the controls have been turned off.

# USING THE TOP OVEN

**Note: DO NOT allow young children near to the appliance when the top oven is in use as the surfaces get hot**

**WARNING: Items stored in the top oven will get hot when the main oven is in use.**

The top oven can be used to cook small quantities of food or used in conjunction with the main oven to provide additional cooking space.

## SHELF POSITIONING

The shelf can be used in three different positions. It has a safety stop to prevent it being pulled out too far when attending to food. The shelf is removed from the oven by pulling it out to the stop and the lifting at the front to withdraw.

## TOP OVEN UTENSILS

The baking dish and the grill pan without the handle can be used in the oven. To ensure good air circulation in the oven, the maximum size of baking tray that should be used is 300mm X 350mm (12" X 14").

## USING THE TOP OVEN

1. Check that the timer is set to manual.
2. Place the shelf in the correct position. ( see cooking chart ).
3. With the top oven door closed, push in and turn the control knob fully anti-clockwise. Sparking will continue until the burner is lit. Turn the control knob clockwise to the required setting (see cooking chart ). There is a delay of about one minute whilst the safety device operates before the burner comes fully on.
4. To turn off, turn the control knob clockwise to the symbol **O**.

**NOTE: The oven burner only operates when the oven door is closed. The oven burner will shut off when the door is opened, and will turn on and reignite when the door is closed again.**

## GUIDANCE ON USING THE TOP OVEN

1. Best results are obtained by pre - heating for about fifteen minutes.
2. The tray or dish on which the food is cooked should be pushed to the back of the shelf.
3. Food which is higher than or will rise above 100mm (4") cannot be cooked in the top oven.

## PLATE WARMING

Place the plates / dishes on the bottom shelf position and turn the control knob to mark 1 for 10 - 15 minutes. **Never use the grill for warming plates.**

## COOLING FAN

A gentle flow of air will be blown below the control panel when any control is used. Whenever the appliance has been used, the cooling fan may continue to run or restart itself after all the controls have been turned off.

# TOP OVEN COOKING CHART

The following times and setting are for guidance only. You may wish to alter the setting to give a result more to your satisfaction. When a different setting to that shown below is given in a recipe, the recipe instructions should be followed. Allow 15 minutes preheat for best results. Always turn the thermostat knob to Mark 8 before selecting the required gas Mark. Shelf position 1 is the highest.

Food	Gas Mark	Shelf Position	Approx. Cooking Time and Comments
<b>FISH</b>		Push dish right to back of shelf.	
Oily and white fish	5	2	20-30 mins.
<b>MEAT AND POULTRY</b>			
Beef (medium)	4 or 5	3	25-30 mins per lb + 25-30 mins
Ham (covered in foil)	5	3	40 mins per lb + 40 mins
Lamb	5	3	30-35 mins per lb + 30 mins
Pork	5	3	40 mins per lb + 40 mins
Chicken	5	3	25 mins per lb + 25 mins
Duckling & Goose	5	3	25 mins per lb + 25 mins
Turkey	4	3	15-20 mins per lb + 15-20 mins
Casseroles	3	3	2-4 hrs. depending on meat used.
<b>VEGETABLES</b>			
Baked jacket potatoes	5	2	1½ - 2 hrs.
<b>PUDDINGS</b>			
Milk Puddings (500ml/1pt)	3	2	1½ - 2 hrs.
Baked Custard (500ml/1pt)	3	2	45 mins - 1 hr. in bain-marie of cold water.
Baked Sponge Puddings	4	2	30 - 45 mins
Baked Apples	3	2	45 mins - 1 hr. depending on size
Meringue Topped Puddings	1	2	25 mins until tinged with brown
Apple Tart (1 x 205mm/8")	6	2	60 mins
Fruit Crumble	5	2	45 - 50 mins

If using aluminium foil:

1. Remember it is important to increase the cooking time by one third.
2. Do not allow the foil to touch the sides of the oven.
3. Do not cover the oven interior with foil.
4. Do not cover the oven shelves with foil.



# TOP OVEN COOKING CHART

Food	Gas Mark	Shelf Positions	Approx. Cooking Time and Comments
<b>CAKES, PASTRIES AND BISCUITS</b>			
Small Cakes (16 per tray)	5	2	20 - 25 mins.
Victoria sandwich (2 x 180mm / 7")	4	2	25 - 30 mins.
Swiss Roll (3 egg quantity)	6	2	10 - 12 mins.
Christmas cake (1 x 205mm / 8")	2	2	4 - 5 hrs depending on recipe
Madeira cake (1 x 180mm / 7")	4	2	1 hr.
Rich Fruit cake (1 x 180mm / 7")	2	2	2 <sup>1</sup> / <sub>4</sub> - 2 <sup>1</sup> / <sub>2</sub> hrs.
Gingerbread	3	2	1 <sup>1</sup> / <sub>2</sub> - 1 <sup>3</sup> / <sub>4</sub> hrs.
Scones - 16 per tray	7	2	12 - 15 mins.
Shortbread (1 x 180mm / 7")	2	2	45 mins. - 1 hr. depending on thickness
Biscuits	4-6	2	15 - 25 mins.
Shortcrust Pastry	6	2	15 mins. - 1 hr. depending on recipe
Rich Short Crust	5	2	20 - 30 mins.
Flaky/Puff Pastry	7	2	10 - 30 mins. depending on recipe
Choux Pastry	6	2	25 - 35 mins.
<b>YEAST MIXTURES</b>			
Bread - rolls, plait	7	2 or 3	25 - 35 mins
Tea breads etc.	5	2	25 - 30 mins
<b>MISCELLANEOUS</b>			
Yorkshire Pudding - small	7	2	20 - 25 mins
- large	7	2	30 - 40 mins
Meringues	1	3	2 <sup>1</sup> / <sub>2</sub> - 4 hrs. turn when necessary

**Soft Margarine** – Use the oven settings recommended by the margarine manufacturer and **not** those indicated on the cooking chart.

# USING THE MAIN OVEN

**Note: DO NOT allow young children near to the appliance when the main oven is in use as the surfaces get extremely hot**

The oven has different heat zones - the temperature control settings refer to the temperature on the middle shelf; above this shelf it is hotter and below it is cooler.

## SHELF POSITIONING

The two shelves can be used in six different positions. Each shelf has a safety stop to prevent it being pulled out too far when attending to food. Shelves are removed from the oven by pulling them out to the stop and the lifting at the front to withdraw.

## MAIN OVEN UTENSILS

The baking dish and the grill pan without the handle can be used in the oven. To ensure good air circulation in the oven, the maximum size of baking tray that should be used is 300mm X 350mm (12" X 14").

## MAIN OVEN OPERATION

1. Check that the timer is set to manual.
2. Place the shelves in the correct position. ( see cooking chart ).
3. With the main oven door closed, push in and turn the control knob fully anti-clockwise. Sparking will continue until the burner is lit. Turn the control knob clockwise to the required setting (see cooking chart ). There is a delay of about one minute whilst the safety device operates before the burner comes fully on.
4. To turn off, turn the control knob fully clockwise to symbol **O**.

**Note: The oven burner only operates when the oven door is closed. The oven burner will shut off when the door is opened, and will turn on and reignite when the door is closed again.**

## COOLING FAN

A gentle flow of air will be blown below the control panel when any control is used. Whenever the appliance has been used, the cooling fan may continue to run or restart itself after all the controls have been turned off.

# USING THE MAIN OVEN

## **COLD START COOKING**

Anything requiring long slow cooking such as casseroles and rich fruit cakes can be put into a cold oven. Satisfactory results can also be obtained with creamed mixture, rich pastries or yeast mixtures, but for perfection we recommend preheating the oven for about 15 minutes at the gas mark you require for cooking.

## **ROASTING OF LARGE POULTRY**

The maximum weight of poultry that can be accommodated is 11.5kg (25 lbs) of suitable shape.

It is important to check that the bird DOES NOT overhang the burner at the back of the oven.

## **STORAGE AND RE-HEATING OF FOOD**

It is vitally important to strictly adhere to the basic principles of food handling and hygiene to prevent the possibility of bacterial growth.

1. If food is to be frozen or not served immediately, cool it in a clean container as quickly as possible.
2. Completely thaw frozen food in the refrigerator before re-heating.
3. Re-heat food thoroughly and quickly either on the hotplate or in a hot oven, Mk. 6, and then serve immediately.
4. Only re-heat food once.

## **'COOK CHILL' DISHES**

These should always be placed in a pre-heated oven ideally on the first or second shelf position. Follow the packet instructions for cooking time.

## **ALUMINIUM FOIL**

If using Aluminium Foil:

1. Remember that it is important to increase the cooking time by one third.
2. Never allow the foil to touch the sides of the oven.
3. Never cover the oven interior with foil.
4. Never cover the oven shelves with foil.

# USING THE MAIN OVEN

The 'S' setting on the main oven thermostat is used for slow cooking, keeping food warm and warming plates for short periods.

## USING THE 'S' SETTING

1. All dishes cooked by the 'S' setting should be cooked for a minimum 6 hours. They will 'hold' at this setting for a further hour but marked deterioration in appearance will be noticed in some cases.
2. Joints of meat and poultry should be cooked at Mk. 6 for 30 minutes before turning to the 'S' setting and never be cooked lower than the middle shelf position.
3. Joints of meat over 6 lbs (2.7kg) and poultry over 4 lbs 8oz (2 kg) should not be cooked using the 'S' setting.
4. Always stand covered joints on a rack over the meat tin to allow good air circulation.
5. A meat thermometer should be used when cooking pork joints and poultry. The internal temperature of the food should reach at least 88°C.
6. This method is unsuitable for stuffed meat and stuffed poultry.
7. Always bring soups, casseroles and liquids to the boil before putting in the oven.
8. Cover casseroles with foil and then the lid to prevent loss of moisture.
9. Always thaw frozen food completely before cooking.
10. Root vegetables will cook better if cut into small pieces.
11. Adjust seasonings and thickenings at the end of the cooking time.
12. Use the zones of heat in the oven, e.g. meringues and milk puddings can be cooked lower in the oven whilst other dishes requiring greater heat can be cooked above them.
13. Egg and fish dishes need only 1-5 hours cooking and should be included in day cooking sessions, when they can be observed from time to time.
14. Dried red kidney beans must be boiled for a minimum of ten minutes after soaking, before inclusion in any dish.

# MAIN OVEN COOKING CHART

The following times and setting are for guidance only. You may wish to alter the setting to give a result more to your satisfaction. When a different setting to that shown below is given in a recipe, the recipe instructions should be followed. Allow 15 minutes preheat for best results. Always turn the thermostat knob to Mark 9 before selecting the required Gas Mark. Shelf position 1 is the highest.

Food	Gas Mark	Shelf Positions	Approx. Cooking Time and Comments
<b>STARTERS</b>			
Patés and Terrines	3 or 4	4	1½ - 2 hrs
<b>FISH</b>			
Oily Fish (whole)	4 or 5	3	25 mins - 1 hr, depending on recipe and size of fish
White Fish (fillets & steaks)	4 or 5	3	25 - 30 mins.
<b>MEAT AND POULTRY</b>			
Veal	5	4	25 mins per lb + 25 mins
Beef	4 or 5	4	25 - 30 mins per lb + 25 mins
Ham	5	4	40 mins per lb covered in foil + 40 mins per lb uncovered
Lamb	5	4	30 - 35 mins per lb + 30 mins
Pork	5	4	40 mins per lb + 40 mins
Chicken	5	4	25 mins per lb + 25 mins
Duckling & gosling	5	4	25 mins per lb + 25 mins
Turkey	4 or 5	4 or 5	15 - 20 mins per lb + 20 mins
Game birds	6	4	50 mins. Remove bacon for last 15 mins. Add extra 15 mins if roasting brace
Casseroles	3	3 or 4	1½ - 6 hrs. (depending on type of meat)
<b>PUDDINGS</b>			
Milk Puddings	3	3	2¼ - 2½ hrs stand dish on a baking tray and started with warm milk
Baked Custard	3	3	45 mins in bain-marie
Baked sponges	4	3	40 - 50 mins
Baked Apples	3	3	30 - 45 mins depending on the size and type of apples
Meringue puddings	1	3	15 mins or until 'tinged' with brown
Apple Pie 1x9" (230mm)	6	2	45 - 55 mins stand dish on a baking tray
Fruit crumbles	5 or 6	3	35 - 45 mins

# MAIN OVEN COOKING CHART

Food	Gas Mark	Shelf Positions	Approx. Cooking Time and Comments
<b>CAKES, PASTRIES AND BISCUITS</b>			
Small cakes - 2 trays	5	2 & 4	17 - 25 mins
- 1 tray	5	2	"
Victoria sandwich 2x8" (205mm)	4	2 & 4	25 - 35 mins
Fatless sponge 2x7" (180mm) - 3 egg mix	5	2	20 - 25 mins. 2 tins side by side
Christmas cake	2	3	4 - 6½ hrs depending on recipe
Madeira cake 7" (180mm)	4	3	1¼ - 1½ hrs
Rich Fruit cake 9" (230mm)	2	3	3 - 3½ hrs.
Shortcrust pastry	6	2	15 mins - 1 hr depending on recipe
Rich Shortcrust pastry - 1 tray	5	2	20 - 40 mins depending on recipe
Flaky & puff pastry - 2 trays	7	2 & 4	10 - 30 mins depending on recipe
- 1 tray		2 or 3	" " " "
Choux pastry - éclairs 1 tray	6	2	35 - 40 mins
Scones - 2 trays	7	2 & 4	10 - 15 mins
- 1 tray		2	"
Shortbread - 7" (180mm) round	2	3	55 - 1hr depending on thickness
Biscuits - 2 trays	4	2 and 4	15 - 20 mins depending on recipe
- 1 tray		2 or 3	" " " "
<b>YEAST MIXTURES</b>			
Bread	7 or 8	3	45 - 50 mins
Rolls	7 or 8	2	15 - 20 mins
Chelsea buns	5	2	20 - 30 mins
<b>MISCELLANEOUS</b>			
Yorkshire Pudding - large	7	2	45 - 50 mins
- individual	7	2	25 - 30 mins
Soufflés	4	2	30 mins
Meringues	'S'	4 & Baseplate	2 - 5 hrs starting on shelf 4 until 'set' and then on the baseplate until dried out - turn when necessary.
Baked Potatoes	4 or 5	2	1½ - 3 hrs until soft, depending on size

When baking with two trays or tins on two levels, the top tray is removed first and the lower tray moved up to the top position for a few minutes longer.

**Soft Margarine** – Use the oven settings recommended by the margarine manufacturer and **not** those indicated on the cooking chart.

# CARE AND CLEANING

**Warning: Before cleaning, please ensure that the electricity supply to the appliance is switched off and the appliance is fully cold.**

## 1. "CREDACLEAN" OVEN LINERS - MAIN OVEN ONLY

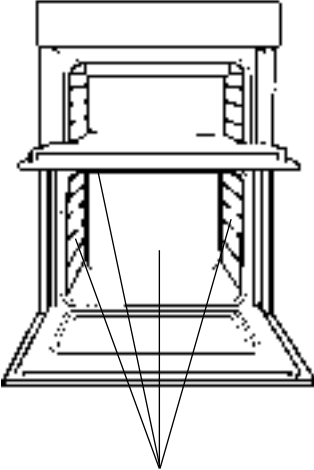

OVEN SIDE LINERS,  
REAR PANEL & ROOF LINER

### (a) How "Credaclean" works.

The surfaces of the "Credaclean" oven liners are treated with a special vitreous enamel which absorbs cooking soils.

At temperatures of mark 7 or above, the special surface enables these soils to be slowly destroyed. The higher the temperature the more effective it is.

### (b) Cleaning.

In most cases normal cooking operations at mark 7 will permit this cleaning operation to proceed during cooking. However if higher cooking temperatures are not used regularly, it may be necessary, in order to prevent heavy soiling, to run the oven without shelves or meat pan, at mark 9 for about 1 hour. During this cleaning cycle, surfaces may become hotter than in normal use. Children should be kept away.

It should not normally be necessary to clean the "Credaclean" panels with water. If the user feels it is desirable to do so, wipe them over with a clean, soapy cloth, followed by a wipe with a clean damp cloth.

**DO NOT use biological washing powder, harsh abrasives or chemical oven cleaners of any kind as this could damage the "Credaclean" oven liners.**

## 2. CLEANING GRILL, TOP OVEN AND MAIN OVEN

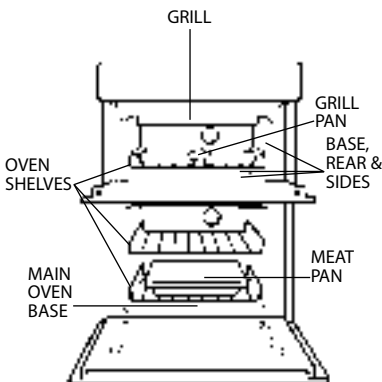

### (a) Base, Sides & Rear of Top Oven and Base of Main Oven.

Wipe out the oven with a damp soapy cloth. For more stubborn stains on the base of the oven use a well soaped fine steel wool soap pad.

### (b) Grill Pan, Meat Pans & Oven Shelves.

To prevent stains from being burnt on to the grill pan, food support and rod shelf, always wash immediately after use in hot soapy water.

Use a well soaped fine steel wool soap pad to remove stubborn stains from the rod shelves, grill pan, meat pan and the base of the oven.

# CARE AND CLEANING

## 3. OVEN DOORS

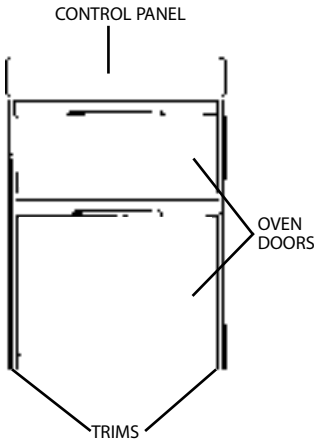

### (a) Control Panel

Regularly wipe with a clean, damp cloth and polish with a clean, dry cloth.

### (b) Trims

Wipe over the trims with a clean, soft cloth wrung out in warm water, or mild non abrasive cleaner. (If in doubt try the cleaner on a small area of trim which is not notice able in normal use), then after wiping with a cloth wrung out in clear water, dry with a clean, soft cloth. Regularly wipe stainless steel trims (if fitted) with a clean damp cloth and polish with a clean dry cloth.

### (c) Inner Door Panels & Glass

Open the door fully. The glass panel may now be washed. Stubborn stains can be removed by using a well soaped, fine steel wool soap pad.

**DO NOT use scouring pads, or abrasive powder, which will scratch the glass.**

## 4. REPLACEMENT OF THE OVEN LAMP

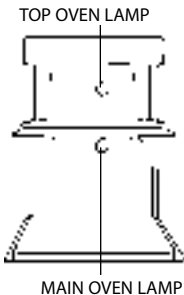

**Warning:**  
To avoid an electric shock, ensure that the electricity supply to the appliance is switched off and the appliance is fully cold before removing lamp lens.

Open the oven door and remove the oven shelves. Using a thick cloth, grip the lamp lens, unscrew anti-clockwise and remove the lens. Carefully unscrew the bulb anti-clockwise. Fit replacement bulb (15W 300°C SES). and refit lens.

## 5. HOW TO CLEAN THE LAMP LENS

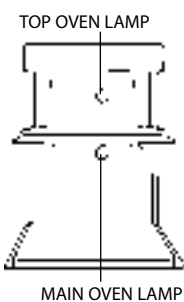

**Warning:**  
To avoid an electric shock, ensure that the electricity supply to the appliance is switched off and the appliance is fully cold before cleaning lamp lens.

Open the oven door and remove the oven shelves. Using a thick cloth, grip the lamp lens, unscrew anti-clockwise and remove. Clean with a non-abrasive cleansing cream and refit lamp lens.

**DO NOT use scouring pads, or abrasive powder, which will scratch the glass lens**



# CARE AND CLEANING

Take particular care not to damage the inner surface of the door inner glass that is coated with a heat reflective layer. Do not use scouring pads, or abrasive powder, which will scratch the glass. Ensure that the glass panel is not subjected to any sharp mechanical blows.

Stubborn stains can be removed by using a fine steel wool pad. For slight soiling the inner glass panel may be cleaned, while still warm, without removing it from the door. After cleaning, rinse and dry with a soft cloth.

## CLEANING THE DOORS

### SIDE OPENING DOORS

Cleaning the door glass is the same as the drop down doors, except take care to support the weight of the inner glass when removing and refitting.

### DROP DOWN DOORS

Remove the door inner glass as follows.

1. Open the door fully and unscrew the two screws securing the glass panel so that the securing brackets can be turned. There is no need to remove the screws completely.

2. Turn the brackets so that the glass can be removed and cleaned at the sink (Fig. 1.)

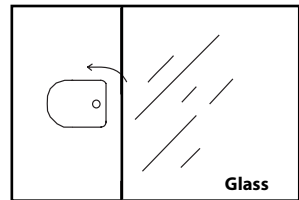

Fig. 1.

3. The inside of the outer door glass can now be cleaned while still fitted to the cooker.

## NEVER OPERATE THE COOKER WITHOUT THE INNER DOOR GLASS IN POSITION.

Refit the door inner glass as follows.

1. **NOTE:** The inner door glass has a special reflective coating on one side. Replace the door inner glass so that the statement: **“IMPORTANT THIS FACE TOWARDS THE OVEN”** can be read from the inner side of the door.
2. Turn the two securing brackets back to their original position to retain the glass and tighten the screws. (Fig. 2.)

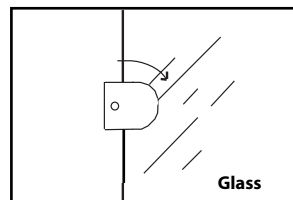

Fig. 2.

# INSTALLATION INSTRUCTIONS

Prior to installation, ensure that the local distribution conditions (nature of the gas and gas pressure) and the adjustment conditions are compatible. The adjustment conditions for this appliance are stated on the data badge which is fitted behind the bottom of the main oven door seal.

This appliance is not designed to be connected to a combustion products evacuation device. It must be installed and connected in accordance with current installation regulations. Particular attention should be given to the relevant requirements regarding ventilation.

## MODEL NUMBER: S230G

### Category I<sub>2H</sub> (GB, IE)

These models are set to burn NATURAL GAS (G20) at 20 mbar ONLY and can not be used on any other gas.

## GAS SAFETY (INSTALLATION & USE) REGULATIONS

It is the law that all gas appliances are installed by competent persons in accordance with the current edition of the above regulations. It is in your interest and that of safety to ensure compliance with the law.

In the UK, CORGI registered installers work to safe standards of practice. The appliance must also be installed in accordance with BS 6172. Failure to install the appliance correctly could invalidate the warranty liability claims and could lead to prosecution.

## LOCATION

The appliance may be located in a kitchen, kitchen/diner or a bed-sitting room, but not in a room containing a bath or shower. The appliance must not be installed in a bed-sitting room of less than 20m<sup>3</sup>.

## PROVISION FOR VENTILATION

The room containing the appliance should have an air supply in accordance with BS 5440: Part 2.

The room must have an opening window or equivalent; some rooms may also require a permanent vent. If the room has a volume between 5 and 10m<sup>3</sup>, it will require an air vent of 50cm<sup>2</sup> effective area unless it has a door which opens directly to outside. If the room has a volume of less than 5m<sup>3</sup>, it will require permanent air vent of 100cm<sup>2</sup> effective area. If there are other fuel burning appliances in the same room, BS 5440: Part 2 should be consulted to determine air vent requirements.

## TECHNICAL DATA

Gas connection	Rp 1/2" (1/2" BSP female)
Gas supply	G20 at 20 mbar.
Pressure test point	Grill injector
Electrical connection	Flexible cord fitted with a 3 pin 13 amp plug. 230 - 240 a.c. 50Hz 3A fuse

BURNER	HEAT INPUT	INJECTOR
Grill	3.4 kW	150
Main Oven	2.4 kW	110
Top Oven	1.65 kW	095

# INSTALLATION

## 1. GENERAL

The appliance is designed for mounting at a safe level into an oven housing which must be secured to the backing wall.

## 2. VENTILATION

- a. The oven housing unit cabinet dimensions must comply with fig. 4.
- b. An air gap of 30mm minimum must be provided at the rear of any top or bottom cupboards or shelves (see fig. 1).
- c. It is necessary that the cabinets are provided with unobstructed ventilation, i.e. from adjacent cabinetry. This can be done by either raising the base of the cabinets using the adjusting feet (or spacers) or alternatively by providing a slot in the cabinet plinth to the dimensions in fig. 1.
- d. The air gap at rear allows the warmed air to pass out of the inner cabinet space. Where it is intended to fit cupboards above the oven unit to ceiling height, it is essential that the warmed air is exhausted through the front of the cabinet (see fig. 1).
- e. If an oven unit is installed adjacent to a tall cabinet, steam escaping from the oven when the door is opened could condense on and maybe stain the adjacent surface. To prevent permanent staining, the adjacent surface should be made of a material that is heat resisting and easy to clean. Adjacent tall cabinets should not be deeper than the oven housing cabinet.

## 3. FINAL INSTALLATION

- a. Using a spirit level, check that the housing cabinet is level from side to side and from front to back in its installed position.
- b. Correct any unevenness by placing spacers under the bottom of the cabinet. Make sure that the cabinet rests firmly on the floor without rocking.
- c. Before the oven is fitted, the cabinet must be firmly secured to the backing wall for stability.
- d. The oven unit should now be lifted (this is a two person lift) into the cabinet and pushed fully home.
- e. Finally, the oven is secured to the cabinet by means of the four Pozi Wash Head screws - two through each side trim.
- f. Remove all packaging material from the grill and oven interior.

## LIST OF LOOSE ITEMS

4 x Pozi Wash Head No. 6 x 15mm screws.

**Note: This appliance must not be installed over any other appliance that generates heat.**

# TALL CABINET VENTILATION

Figure. 1

**Ventilation Slot** required  
here if cabinet **does not**  
fit to ceiling - **50mm x 450mm** min. area

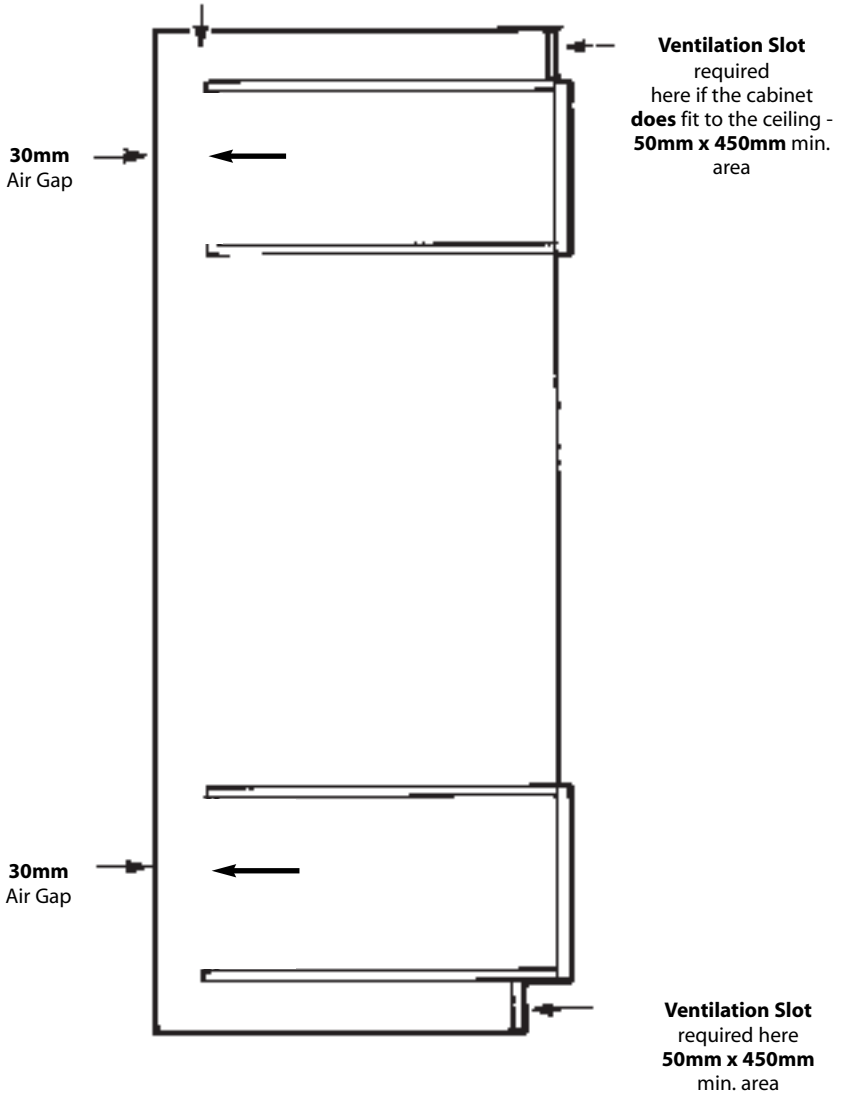

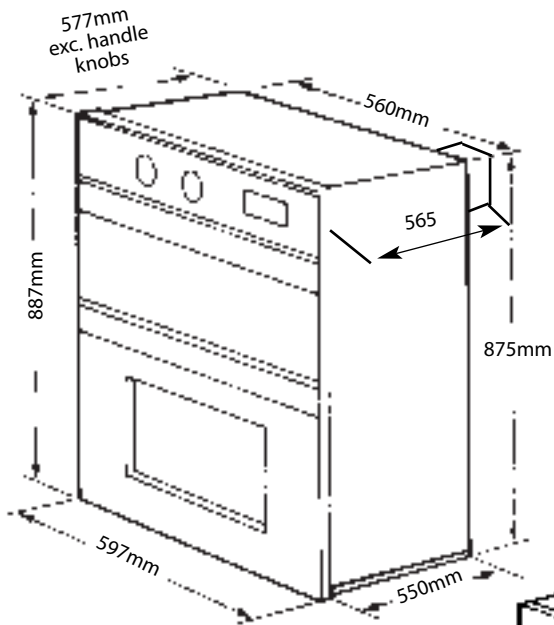

Fig. 2

The appliance can be installed into a cabinet of minimum depth 550mm providing a suitable means of connection to the gas supply can be made.

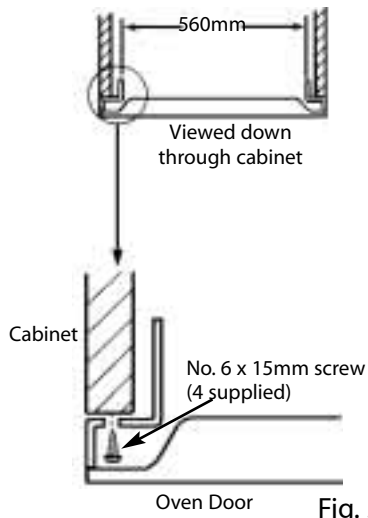

Fig. 3

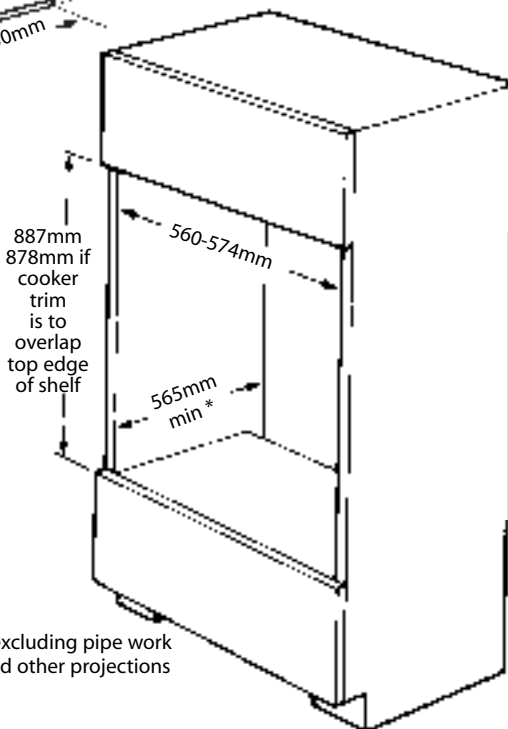

Fig. 4

\* excluding pipe work and other projections

# INSTALLATION INSTRUCTIONS

## CONNECTING TO GAS SUPPLY

The oven is designed to be connected with an approved appliance flexible connection to BS 669. A length of 1.25 to 1.55m is recommended. An adaptor backplate should be fitted in the area shown to allow the appliance to be pushed fully back into the cabinet. The flexible hose should be fitted such that it cannot come into contact with moveable parts of the housing unit (e.g. a drawer) and does not pass through a space where it is likely to become trapped or damaged. The temperature rise of areas at the rear of the appliance that are likely to come in contact with the flexible hose do not exceed 70°C.

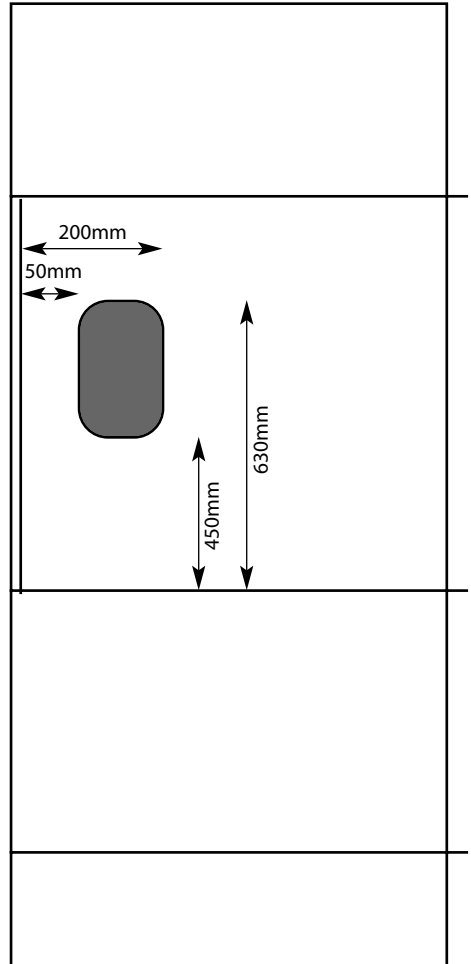
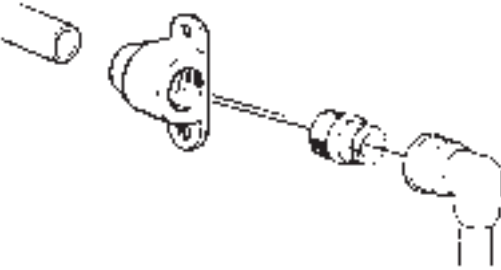

## CABINETS LESS THAN 565mm DEEP

The appliance can be fitted into a cabinet of minimum depth 550mm providing a suitable connection to the gas supply can be made. The wall behind the appliance will need to be chased away behind the appliance gas inlet. The gas connection can either be made with a flexible hose or 8mm minimum diameter rigid piping, leading below or to the sides of the appliance. Where rigid piping is used, an accessible isolation tap with suitable means of disconnection must be provided to allow for servicing.

# ELECTRICAL CONNECTION

## **WARNING – THIS APPLIANCE MUST BE EARTHED. CONNECT TO A 230-240V A.C. SUPPLY ONLY.**

Connection to the electricity supply should be made via a properly earthed, readily accessible wall socket which is adjacent to, and not more than 1.25m away from the appliance and capable of electrical isolation.

The mains lead should be routed such that it cannot touch hot parts of the appliance i.e. the back panel above a height of 350mm from the bottom of the oven recess. If the oven is to be wired into a connector unit, this may be positioned behind the oven providing the following requirements are met:

- i) The connector unit must not project more than 25mm from the wall.
- ii) The top of the connector unit must not be more than 350mm above the base of the oven recess.

**NOTE: The removed plug cannot be used for any other appliance and should therefore be properly disposed of and not left where children might find it and plug it into a supply socket – with the obvious consequent danger.**

### **IF THE FITTED PLUG IS REMOVED**

The flexible mains lead must be correctly connected as below to a three pin plug of not less than 13 amp capacity. If a B.S. 1363 fused plug is used, it must be fitted with a 3 amp fuse which is approved to B.S. 1362.

**IMPORTANT:** The wires in the mains lead fitted to this appliance are coloured in accordance with the following code:

GREEN AND YELLOW	– EARTH
BLUE	– NEUTRAL
BROWN	– LIVE

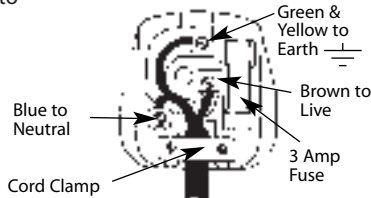

As the colours of the wires in the mains lead of this appliance may not correspond with the coloured markings identifying the terminals in your plug, proceed as follows:- The wire which is coloured green and yellow must be connected to the terminal in the plug which is marked with the letter E or by the earth symbol  $\equiv$  or coloured green or green and yellow. The wire which is coloured blue must be connected to the terminal which is marked with the N or coloured black. The wire which is coloured brown must be connected to the terminal which is marked with the letter L or coloured red. When wiring the plug, ensure that all strands of wire are securely retained in each terminal. Do not forget to tighten the mains lead clamp on the plug. As the appliance must be earthed, **do not use 2-pin sockets outlets, if you are in doubt, consult a qualified electrician.**

Should the mains lead ever require replacement, it is essential that this operation be carried out by a qualified electrician and should only be replaced with a flexible cord of the same size i.e. 0.75mm<sup>2</sup> cross sectional area and temperature rating of 85°C e.g. heat resisting PVC.

### **IF A MOULDED PLUG IS FITTED**

In the event of replacing a fuse in the plug supplied a 3 amp ASTA approved fuse to BS1362 must be fitted.

**NOTE:** The fuse cover must be refitted when changing the fuse. In the event of losing the fuse cover the plug must not be used until a replacement fuse cover has been obtained and fitted. A new fuse cover can be obtained from your local electrical retailer. The colour of the correct replacement fuse cover is that of the coloured marks or inserts in the base of the plug.

# INSTALLATION INSTRUCTIONS

## INSTALLATION AND OPERATIONAL CHECKS

After installation, check for gas soundness. The supply pressure can be checked at the grill injector. Loosen the fastening screw on the left hand side of the grill burner and slide the burner to the right and then off the injector. Ensure that the grill burner is correctly located and the fixing screw tightened on reassembly.

1. Check that the grill burner ignites correctly and burns with a steady flame. Check for a steady flame on the low setting.
2. Check that, with the main oven set to mark 9, the burner ignites at low rate, and then increases to full rate within 60 seconds. Leave the oven full on with the door closed for 10 minutes, and check that when the control is turned to the 'S' setting that the flame reduces.
3. Check that, with the top oven set to mark 8, the burner ignites at low rate, and then increases to full rate within 60 seconds. Leave the oven full on with the door closed for 10 minutes, and check that when the control is turned to mark 1 that the flame reduces.
4. Check the operation of the oven timer, oven light(s) & cooling fan.

Instruct the user on operation of the appliance.



# SOMETHING WRONG?

**Before calling a Service Engineer, please check through the following lists.  
THERE MAY BE NOTHING WRONG.**

<b>Problem</b>	<b>Check</b>
<b>Nothing works.</b>	If the timer display is blank. <b>Then it is likely that there is no electricity supply to your oven.</b> Check: (i) That the main cooker wall switch is turned on. (ii) Check other appliances to see if you have a power cut. (iii) Check the main circuit breaker for the property.
<b>Display shows 0.00 AUTO.</b>	The power supply to your oven has possibly been interrupted, but has now come back on again. Reset the timer to the correct time of day and "Manual" operation using instructions given in the timer section of the book.
<b>Timer display shows " Auto " lit up or flashing.</b>	To use the ovens or grill the timer must be set to manual mode. See timer instructions.
<b>Timer display correct but appliance will not operate</b>	The appliance incorporates a safety device to shut down the burners in the event of a fault, to prevent overheating. In this case contact your service engineer to have the fault rectified and the safety device reset.
<b>Can not set an "Auto Cook" programme</b>	Remember that " Cook period " is the actual length of time for which the timer will switch the oven(s) on as part of an "Auto cooking " programme.
<b>Draught from beneath control panel.</b>	A gentle flow of air will be blown from beneath the control panel when the appliance is used. If the appliance is still warm, this cooling fan may continue to run, or restart itself after all controls have been turned off. The fan will stop once the appliance has cooled.
<b>Cooling fan not operating</b>	If no air is blown from below the control panel when the controls are switched on and you have checked through the " Nothing works " section above, then the cooling fan may be faulty. In this case you should turn off the appliance and contact your service agent to arrange for a repair.
<b>Oven burner not working</b>	Note that the oven burners only operate when the door is closed to ensure safe operation and avoid wasting heat. With the door closed the oven burner will ignite.
<b>Oven appears to be cooking at too high a temperature.</b>	It may be necessary to turn to a lower setting than shown on the cooking chart or recipe as results depend on personal tastes. If the oven appears to be cooking at too high a temperature than previously, and turning down the thermostat has no effect, then the thermostat may be faulty and you should contact your service agent.
<b>Timer buzzer/bleeper operates continually</b>	Buzzer / bleeper should stop automatically after two minutes. If not. press minute minder button to silence.

**If you have been through the above list and there is still a problem; contact our Service department (see Key Contacts, back page).**

# NOTES

# NOTES

# ***Key Contacts***

## ***Service***

Creda has the largest appliance manufacturer's service team in Europe, trained specialists directly employed by us to ensure your complete confidence.

### ***Repair Service***

***UK: 08709 066 066***

***Republic of Ireland: 1850 302 200***

You will be asked for the following information:-

Name, address and postcode.

Telephone number

Model / Serial number of the appliance

Clear and concise details of the query or fault

Place and Date of purchase

(Please keep the receipt as evidence will be required when the engineer calls).

### ***Extended Warranty***

***To join: UK 08709 088 088***

***Republic of Ireland: 1850 502 200***

### ***Genuine Parts & Accessories***

#### ***Mail Order Hotline***

***UK: 08709 077 077***

***Republic of Ireland: (01) 842 6836***

For further product information 08701 546474

All Creda Services are offered as an extra benefit and do not affect your statutory rights.



**Merloni Elettrodomestici UK Limited, Morley Way, Peterborough, PE2 9JB**