



**PARTS
CATALOGUE
CATALOGUE
DE PIÈCES DÉTACHÉES**

F6AMH'07 (60N3)
F8CMH'07 (60R3)

F6AMH/F8CMH
PARTS CATALOGUE
©2006 by Yamaha Motor Co., Ltd.
1st edition, June 2006
All rights reserved.
Any reprinting or unauthorized use
without the written permission of
Yamaha Motor Co., Ltd.
is expressly prohibited.
Printed in Japan.

F6AMH/F8CMH
CATALOGUE DE PIECES DETACHEES
©2006 par Yamaha Motor Co., Ltd.
1^{re} édition, juin 2006
Tous droits réservés
Toute réimpression ou utilisation
non autorisée sans la permission écrite
de la Yamaha Motor Co., Ltd.
est formellement interdite.
Imprimé au Japon

FOREWORD

This Parts Catalogue is related to the parts for the model(s) on the cover page. When you are ordering replacement parts, please refer to this Parts Catalogue and quote both part numbers and part names correctly.

1. Modifications or additions which have been made after the issue of the Parts Catalogue will be announced in the Parts News.
It is advisable that you make the necessary corrections to the Parts Catalogue according to the Parts News.

2. Abbreviations

The following abbreviations are used in this Parts Catalogue.

“UR” Use specified parts number.

“UN” Use as many as needed.

“AP” Alternate Parts

“LM” Locally Made (Parts need to be ordered locally)

“F#” Frame No. (Applicable machine No.)

“O/S” Over Size

3. The number of components for assembly

- Parts, which are to be supplied in an assembly, are listed with a dot (.) in front of the part name as shown below.
- The numeral appearing to the right of each component part indicates the quantity of parts for each assembly unit.

PART NO.	DESCRIPTION	Q'TY	REMARKS
2F5-83310-60	FRONT FLASHER LIGHT ASSY	2	
115-83311-60	.BULB (6V-18W)	1	

4. Applicable colours of graphics are represented in the “REMARKS” as shown below.

PART NO.	DESCRIPTION	Q'TY	REMARKS
2N4-24110-00-X5	FUEL TANK COMP.	2	MXR
3J1-24240-10	.GRAPHIC, FUEL TANK	1	FOR MXR

5. Note that the illustrations for reference in finding parts numbers are not to be used for assembling. When assembling, please use the applicable service manual.

6. The asterisk (*) before a reference number indicates modified items after the first edition.

7. Applicable Serial No.

Engine Serial No.

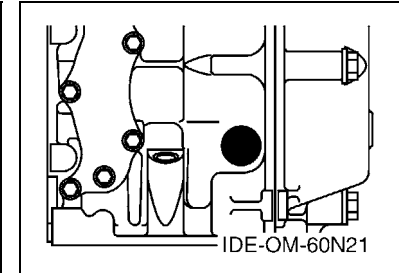
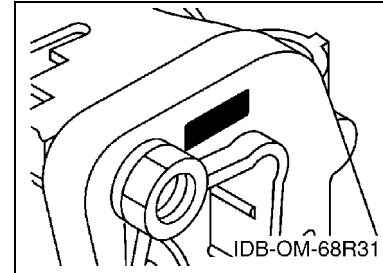

8. Applicable Engine Starting Serial No.

Model	Serial No.	Model	Serial No.
F6A	60N-1005836	F8C	60R-1010031

9. Applicable Colour Code

Abbreviation	Colour Name	Colour Code
DBNM2	DARK BLUISH GRAY METALLIC 2	004D

10. Quantity Column Information

Column No.	Name Of Q'ty Column	Applicable Model
1	60N3	F6AMH
2	60R3	F8CMH

AVANT-PROPOS

Ce catalogue de pièces détachées concerne les pièces pour le(s) modèle(s) indiqué(s) sur la page de couverture. Lorsque vous commandez des pièces de rechange, veuillez vous référer à ce catalogue de pièces détachées et indiquer clairement les numéros et les noms des pièces détachées.

1. Les modifications ou ajouts ayant été effectués après la parution du catalogue de pièces détachées seront décrits dans les Bulletins d'information concernant les pièces détachées.

Il est recommandé que vous apportiez les corrections nécessaires au catalogue des pièces détachées en vous référant aux Bulletins d'information.

2. Abréviations

Dans ce catalogue, les abréviations suivantes sont utilisées:

“UR” Utiliser le numéro de pièces spécifié.

“UN” Utiliser autant que nécessaire.

“AP” Pièces de substitution

“LM” Fabrication locale (les pièces doivent être commandées localement.)

“F#” N° de cadre (applicable au N° de série)

“O/S” Surdimensionné

3. Nombre de pièces d'un assemblage

- Les pièces fournies comme composants d'un assemblage sont précédées d'un point (.) de la manière indiquée ci-dessous.
- Le chiffre apparaissant à la droite de chaque composant indique la quantité de pièces pour chaque unité d'assemblage.

N° PIÈCES	DESCRIPTION	QTE	REMARQUES
2F5-83310-60	ENS. CLIGNOTANT AVANT	2	
115-83311-60	.AMPOULE (6V-18W)	1	

4. Les couleurs concernant les graphiques sont indiquées dans la colonne “REMARQUES”, comme indiqué ci-dessous.

N° PIÈCES	DESCRIPTION	QTE	REMARQUES
2N4-24110-00-X5	RESERVOIR A ESSENCE.	2	MXR
3J1-24240-10	.GRAPHIQUE	1	POUR MXR

5. Veuillez noter que les illustrations sont indiquées à titre de référence pour trouver les numéros de pièces, non pour être utilisées lors de l'assemblage. Lors de l'assemblage, veuillez utiliser le manuel d'entretien adéquat.

6. L'astérisque (*) placé devant un numéro de référence indique des éléments qui ont été modifiés après la première édition.

7. N° de série applicable

N° de Série du moteur

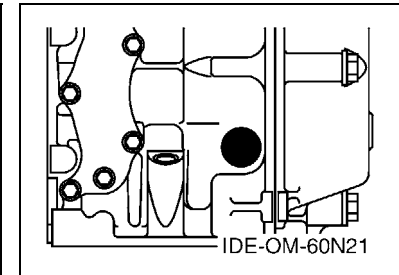
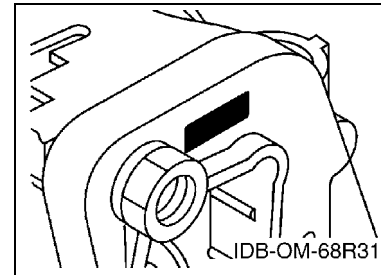

8. N° de série initial du moteur applicable

Modèle	N° de série	Modèle	N° de série
F6A	60N-1005836	F8C	60R-1010031

9. Code couleur applicable

Abréviation	Nom de la couleur	Code couleur
DBNM2	DARK BLUISH GRAY METALLIC 2	004D

10. Informations relatives à la colonne Quantité

N° de la colonne	Nom de la colonne Qté	Modèle applicable
1	60N3	F6AMH
2	60R3	F8CMH

CONTENTS

TOP COWLING	A4
CYLINDER & CRANKCASE 1	A5
CRANKSHAFT & PISTON	A6
CYLINDER & CRANKCASE 2	A7
VALVE	B1
INTAKE	B2
CARBURETOR	B3
OIL PUMP	B4
FUEL	B5
STARTER	B7
GENERATOR	C2
ELECTRICAL 1	C3
ELECTRICAL 2	C4
BOTTOM COWLING	C5
STEERING	C7
CONTROL	D2
REMO CON ATTACHMENT	D4
BRACKET 1	D5
BRACKET 2	D7
UPPER CASING	E1
OIL PAN	E2
LOWER CASING & DRIVE 1	E3
LOWER CASING & DRIVE 2	E6
FUEL TANK	E7
STEERING GUIDE	F1
OPTIONAL PARTS 1	F2
OPTIONAL PARTS 2	F4
REPAIR KIT 1	F5
REPAIR KIT 2	F6
REPAIR KIT 3	F7
INDEX	
NUMERICAL INDEX	G1

TABLE DES MATIERES

CAPOT SUPERIEUR	A4
CYLINDRE & CARTER 1	A5
VILEBREQUIN & PISTON	A6
CYLINDRE & CARTER 2	A7
SOUPAPE	B1
ADMISSION	B2
CARBURATEUR	B3
POMPE A HUILE	B4
CARBURANT	B5
DEMARREUR	B7
GENERATRICE	C2
PARTIE ELECTRIQUE 1	C3
PARTIE ELECTRIQUE 2	C4
CAPOT INFERIEUR	C5
DIRECTION	C7
COMMANDE	D2
COMMANDE A DISTANCE	D4
SUPPORT 1	D5
SUPPORT 2	D7
FOURREAU	E1
VENTILATEUR D'HUILE	E2
BOITIER D'HELICE TRANSMISSION1	E3
BOITIER D'HELICE TRANSMISSION2	E6
RESERVOIR A CARBURANT	E7
FIXATION DE DIRECTION	F1
PIECES OPTIONNELLES 1	F2
PIECES OPTIONNELLES 2	F4
KITS DE REPARATION 1	F5
KITS DE REPARATION 2	F6
KITS DE REPARATION 3	F7
INDEX	
INDEX NUMERIQUE	G1

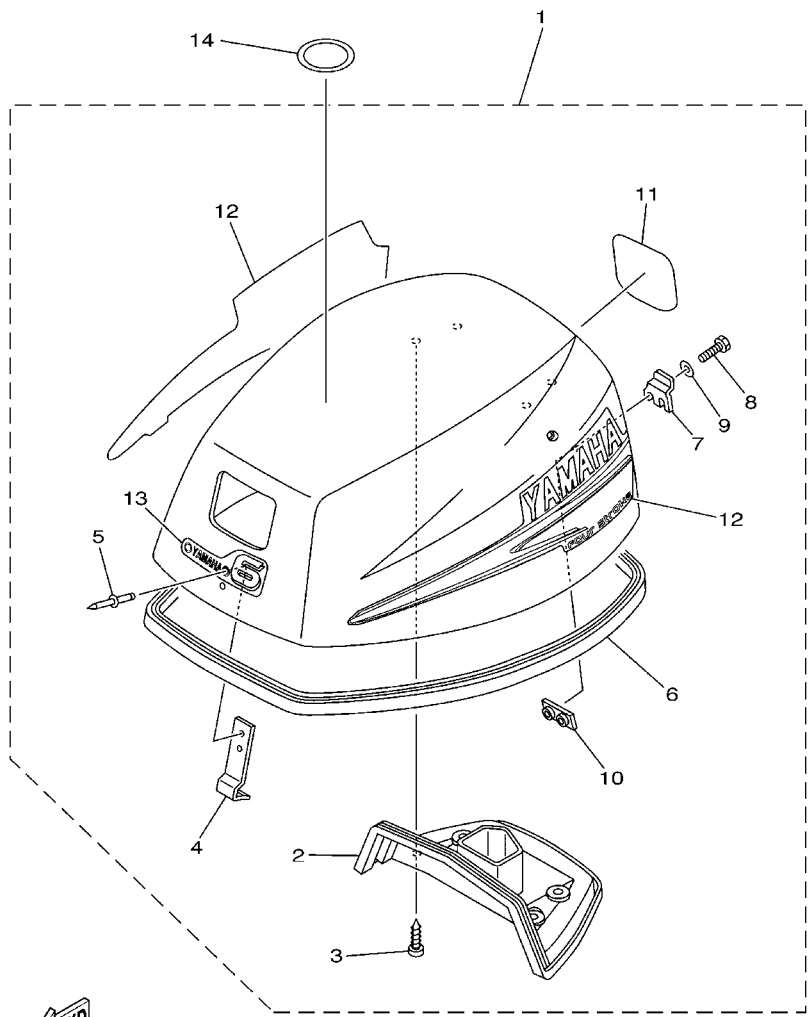

68R1010-2010

FIG. 1 TOP COWLING

CAPOT SUPERIEUR

REF. NO.	PART NO. N° PIECES	DESCRIPTION DESCRIPTION	60N3	60R3		REMARKS REMARQUES
1	60N-G2610-00-4D	TOP COWLING ASSY CAPOT (ENS.)	1			
	60R-G2610-00-4D	TOP COWLING ASSY CAPOT (ENS.)		1		
2	60R-G2613-00	.MOLDING, AIR DUCT .MANCHON A AIR	1	1		
3	97780-60516	.SCREW, TAPPING .VIS, TETE BOMBEE	4	4		
4	6G1-42651-02	.HOOK .CROCHET	1	1		
5	90266-04M04	.RIVET .RIVET	2	2		
6	60R-42615-00	.SEAL .JOINT	1	1		
7	60R-42652-00	.HOOK .CROCHET	1	1		
8	97095-05014	.BOLT .BOULON	2	2		
9	92995-05600	.WASHER .RONDELLE	2	2		
10	68T-42649-00	.HOLDER, CLAMP BAND .SUPPORT, SANDOW DE SERRAGE	1	1		
11	68R-42678-20	.GRAPHIC, REAR .ADHESIF, ARRIERE	1			
	68T-42678-20	.GRAPHIC, REAR .ADHESIF, ARRIERE		1		
12	68T-W0070-60	.GRAPHIC SET .JEU DIEMBLEMES	1	1		
13	68R-42677-00	.GRAPHIC, FRONT .ADHESIF, AVANT	1			
	68T-42677-00	.GRAPHIC, FRONT .ADHESIF, AVANT		1		
14	60R-E3434-00	LABEL, CAUTION ETIQUETTE, ATTENTION	1	1		

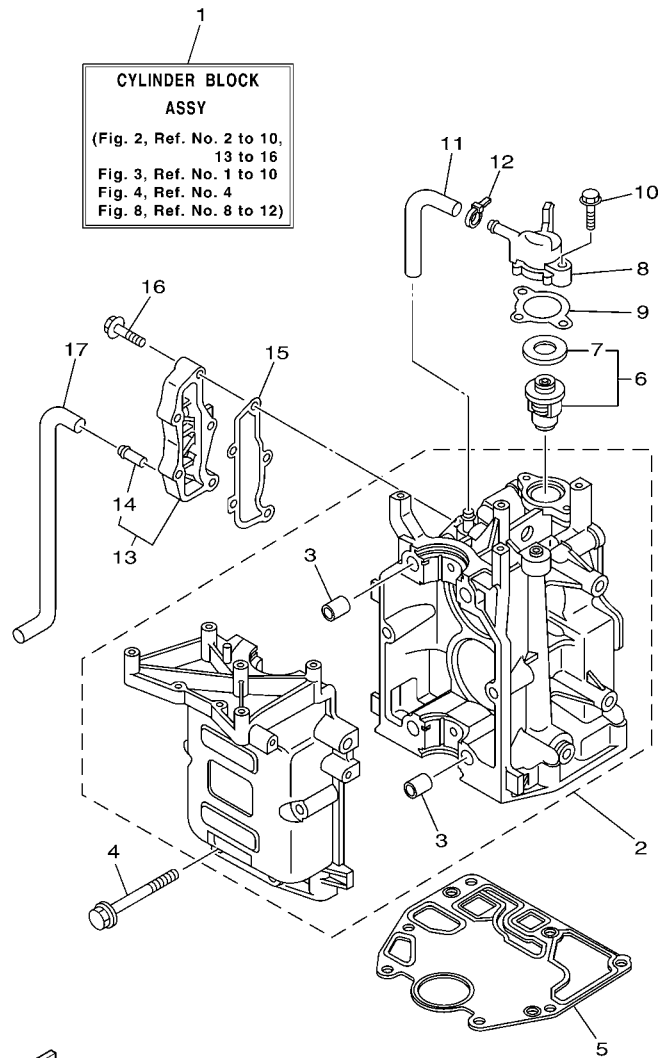
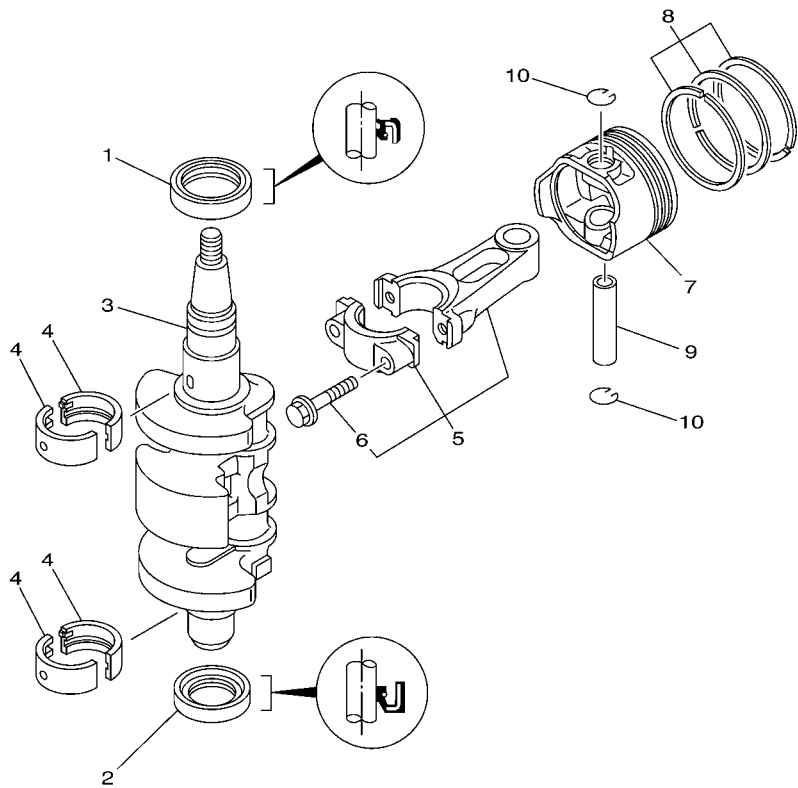

FIG. 2 CYLINDER & CRANKCASE 1 CYLINDRE & CARTER 1

REF. NO.	PART NO. N° PIECES	DESCRIPTION DESCRIPTION	60N3	60R3		REMARKS REMARQUES
1	60R-WE09B-00-1S	CYLINDER BLOCK ASSY CYLINDRE GROUPE (ENS.)	1	1		
2	60R-E5100-00-1S	CRANKCASE ASSY CARTER DE MOTEUR COMPLET	1	1		
3	91812-12001	.PIN, DOWEL .GOUJON, D'ASSEMBLAGE	4	4		
4	90119-08M29	BOLT, WITH WASHER BOULON, AVEC RONDELLE	6	6		
5	68T-11351-00	GASKET, CYLINDER JOINT, D'EMBASE	1	1		
6	66M-12411-01	THERMOSTAT THERMOSTAT	1	1		
7	688-12412-00	.SEAL, THERMOSTAT .JOINT, THERMOSTAT	1	1		
8	68T-12413-00-1S	COVER, THERMOSTAT COUVERCLE, THERMOSTAT	1	1		
9	60R-E2414-A0	GASKET, COVER JOINT, COUVERCLE	1	1		
10	90119-06MA2	BOLT, WITH WASHER BOULON, AVEC RONDELLE	2	2		
11	60R-E2481-00	PIPE 1 DURITE 1	1	1		
12	90465-11M10	CLAMP BRIDE	1	1		
13	60R-G1113-00-1S	OUTER COVER, EXHAUST COUVERCLE, ECHAPPEMENT	1	1		
14	6E9-24378-00	.PIPE, JOINT 4 .DURITE RACCORDEMENT 4	1	1		
15	68T-41114-A0	GASKET, EXHAUST OUTER COVER JOINT, COUVERCLE D'ECHAPPEMENT	1	1		
16	90119-06MA3	BOLT, WITH WASHER BOULON, AVEC RONDELLE	5	5		
17	60R-E2482-00	PIPE 2 DURITE 2	1	1		

FIG. 3 CRANKSHAFT & PISTON

VILEBREQUIN & PISTON



REF. NO.	PART NO. N° PIECES	DESCRIPTION DESCRIPTION	60N3	60R3	REMARKS REMARQUES
1	93102-30M22	OIL SEAL JOINT SPY	1	1	
2	93101-25M69	OIL SEAL JOINT SPY	1	1	
3	60R-E1411-00	CRANKSHAFT VILEBREQUIN COMPLET	1	1	
4	68T-11416-00	PLANE BEARING, CRANKSHAFT 1 COUSSINET DE VILEBREQUIN 1	4	4	UR BROWN UR BROWN
	68T-11416-10	PLANE BEARING, CRANKSHAFT 1 COUSSINET DE VILEBREQUIN 1	4	4	UR BLACK UR BLACK
	68T-11416-20	PLANE BEARING, CRANKSHAFT 1 COUSSINET DE VILEBREQUIN 1	4	4	UR BLUE UR BLUE
5	68T-11650-00	CONNECTING ROD ASSY BIELLE COMPLETE	2	2	
6	67D-11654-00	.BOLT, CONNECTING ROD .BOULON, BIELLE	2	2	
7	60R-E1631-00-96	PISTON (STD) PISTON (STD)	2	2	
	60R-E1635-00	PISTON (0.25MM O/S) PISTON (0.25MM O/S)	2	2	AP AP
	60R-E1636-00	PISTON (0.50MM O/S) PISTON (0.50MM O/S)	2	2	AP AP
8	60R-E1603-00	PISTON RING SET (STD) JEU DE SEGMENTS (STD)	2	2	
	60R-E1604-00	PISTON RING SET (0.25MM O/S) JEU DE SEGMENTS (0.25MM O/S)	2	2	AP AP
	60R-E1605-00	PISTON RING SET (0.50MM O/S) JEU DE SEGMENTS (0.50MM O/S)	2	2	AP AP
9	60R-E1633-00	PIN, PISTON AXE, PISTON	2	2	
10	93450-15023	CIRCLIP CIRCLIP, TYPE S	4	4	



68R0010-0031

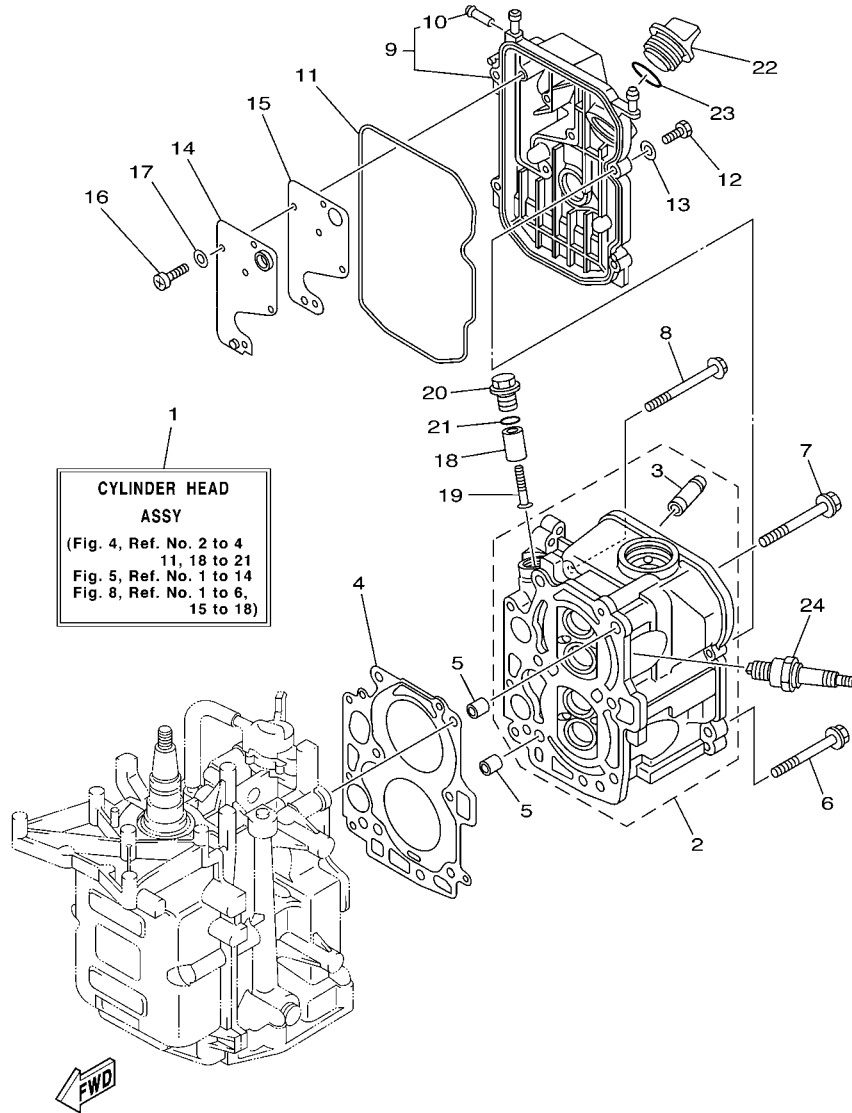

68R2100-3040

FIG. 4 CYLINDER & CRANKCASE 2 CYLINDRE & CARTER 2

REF. NO.	PART NO. N° PIECES	DESCRIPTION DESCRIPTION	60N3	60R3		REMARKS REMARQUES
1	60R-WE09A-00-1S	CYLINDER HEAD ASSY CULASSE (ENS.)	1	1		
2	60R-E1111-00-1S	HEAD, CYLINDER 1 CULASSE	1	1		
3	67D-11133-10	.GUIDE, VALVE 1 .GUIDE, SOUPAPE 1	4	4		
4	68T-11181-00	GASKET, CYLINDER HEAD 1 JOINT, DE CULASSE 1	1	1		
5	99510-10114	PIN, DOWEL GOUJON, D'ASSEMBLAGE	2	2		
6	90105-08M36	BOLT, FLANGE BOULON	2	2		
7	90105-08M78	BOLT, FLANGE BOULON	4	4		
8	90119-06049	BOLT, WITH WASHER BOULON, AVEC RONDELLE	3	3		
9	60R-E1191-00-1S	COVER, CYLINDER HEAD 1 COUVERCLE, CULASSE 1	1	1		
10	650-24378-00	.PIPE, JOINT 4 .DURITE RACCORDEMENT 4	1	1		
11	68T-11356-00	SEAL, CYLINDER 2 JOINT, SPY CYLINDRE	1	1		
12	97095-06020	BOLT BOULON	4	4		
13	92995-06600	WASHER RONDELLE	4	4		
14	68T-11168-00	COVER, BREATHER COUVERCLE, RENIFLARD	1	1		
15	68T-11169-A0	GASKET, BREATHER COVER JOINT, COUVERCLE DE RENIFLARD	1	1		
16	98507-04010	SCREW, PAN HEAD VIS, TETE TRONCONIQUE	5	5		
17	92907-04600	WASHER RONDELLE	5	5		
18	6G8-11325-00	ANODE ANODE	1	1		
19	97880-05025	SCREW, PAN HEAD VIS, TETE TRONCONIQUE	1	1		
20	6G8-11197-01	PLUG, BLIND PLOT, BORGNE	1	1		
21	93210-13M63	O-RING JOINT TORIQUE	1	1		
22	69M-E5363-00	PLUG, OIL PLOT, HUILE	1	1		
23	93210-24M79	O-RING JOINT TORIQUE	1	1		
24	94702-00274	PLUG, SPARK (NGK BR6HS-10) BOUGIE D'ALLUMAGE(NGK BR6HS-10)	2	2		

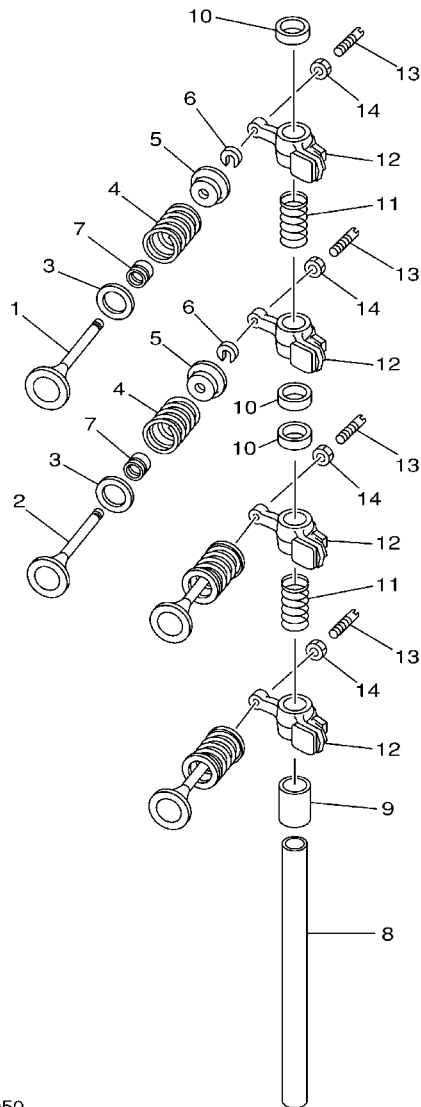

68R0010-0050

FIG. 5 VALVE

SOUPAPE

REF. NO.	PART NO. N° PIECES	DESCRIPTION DESCRIPTION	60N3	60F3		REMARKS REMARQUES
1	67D-12111-00	VALVE, INTAKE SOUPAPE, ADMISSION	2	2		
2	67D-12121-00	VALVE, EXHAUST SOUPAPE, ECHAPPEMENT	2	2		
3	68T-12116-00	SEAT, VALVE SPRING SIEGE, RESSORT DE SOUPAPE	4	4		
4	60R-E2113-00	SPRING, VALVE INNER RESSORT DE SOUPAPE, INTERNE	4	4		
5	7NJ-12117-00	RETAINER, VALVE SPRING BUTEE DE RESSORT DE SOUPAPE	4	4		
6	7NJ-12118-00	COTTER, VALVE FRAISE, SOUPAPE	4	4		
7	51Y-12119-00	SEAL, VALVE STEM JOINT, QUEUE DE SOUPAPE	4	4		
8	68T-12146-00	SHAFT, ROCKER AXE, CULBUTEUR	1	1		
9	90387-13M56	COLLAR COLLERETTE	1	1		
10	90387-14M03	COLLAR COLLERETTE	3	3		
11	90501-12M40	SPRING, COMPRESSION RESSORT, COMPRESSION	2	2		
12	68T-12151-00	ARM, VALVE ROCKER CULBUTEUR	4	4		
13	6G8-12159-00	SCREW, VALVE ADJUSTING VIS, REGLAGE DE SOUPAPE	4	4		
14	6G8-12158-00	NUT, LOCK CONTRE-ECROU	4	4		

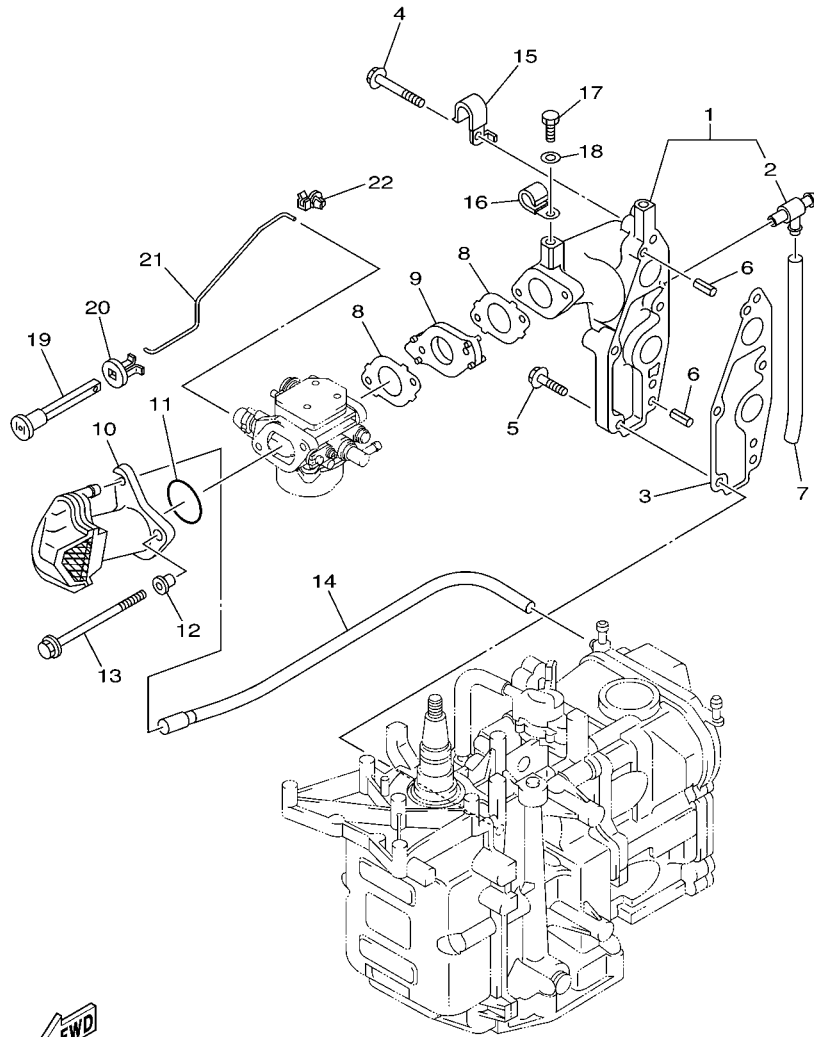

 60S1100-D060

FIG. 6 INTAKE

ADMISSION

REF. NO.	PART NO. N° PIECES	DESCRIPTION DESCRIPTION	60N3	60R3	REMARKS REMARQUES
1	60R-E3641-20-1S	MANIFOLD 1 TUBULURE 1	1	1	FLUSHING KIT FLUSHING KIT
2	67F-12482-00	.PIPE 2 .DURITE 2	1	1	
3	68T-13645-00	GASKET, MANIFOLD 1 JOINT, TUBULURE 1	1	1	
4	90119-06MA5	BOLT, WITH WASHER BOULON, AVEC RONDELLE	3	3	
5	90119-06MA3	BOLT, WITH WASHER BOULON, AVEC RONDELLE	2	2	
6	91690-50014	PIN, SPRING AGRAFFE	2	2	
7	90445-09812	HOSE (L93) DURITE (L93)	1	1	FLUSHING KIT FLUSHING KIT
8	60R-E3646-A0	GASKET, MANIFOLD 2 JOINT, TUBULURE 2	2	2	
9	68T-14271-00	INSULATOR ISOLATEUR	1	1	
10	60R-E4440-00	SILENCER ASSY, INTAKE SIENCIEUX D'ADMISSION	1	1	
11	93210-31MJ5	O-RING JOINT TORIQUE	1	1	
12	90387-06M70	COLLAR COLLERETTE	2	2	
13	97595-06585	BOLT, WITH WASHER VIS HEXAGONAL AVC RONDELLE	2	2	
14	60R-E2483-00	PIPE 3 DURITE 3	1	1	
15	90465-08M99	CLAMP BRIDE	1	1	
16	90465-08M83	CLAMP BRIDE	1	1	FLUSHING KIT FLUSHING KIT
17	97095-06010	BOLT BOULON	1	1	FLUSHING KIT FLUSHING KIT
18	92995-06600	WASHER RONDELLE	1	1	FLUSHING KIT FLUSHING KIT
19	6H4-41271-01	KNOB, CHOKE BOUTON DE STARTER	1	1	
20	689-41273-00	GROMMET PASSE-FIL	1	1	
21	68T-41256-00	ROD, CHOKE 1 TRINGLE 1, STARTER	1	1	
22	6J8-41262-00	JOINT, CHOKE LEVER RACCORD, LEVIER DE STARTER	1	1	

FIG. 7 CARBURETOR

CARBURATEUR

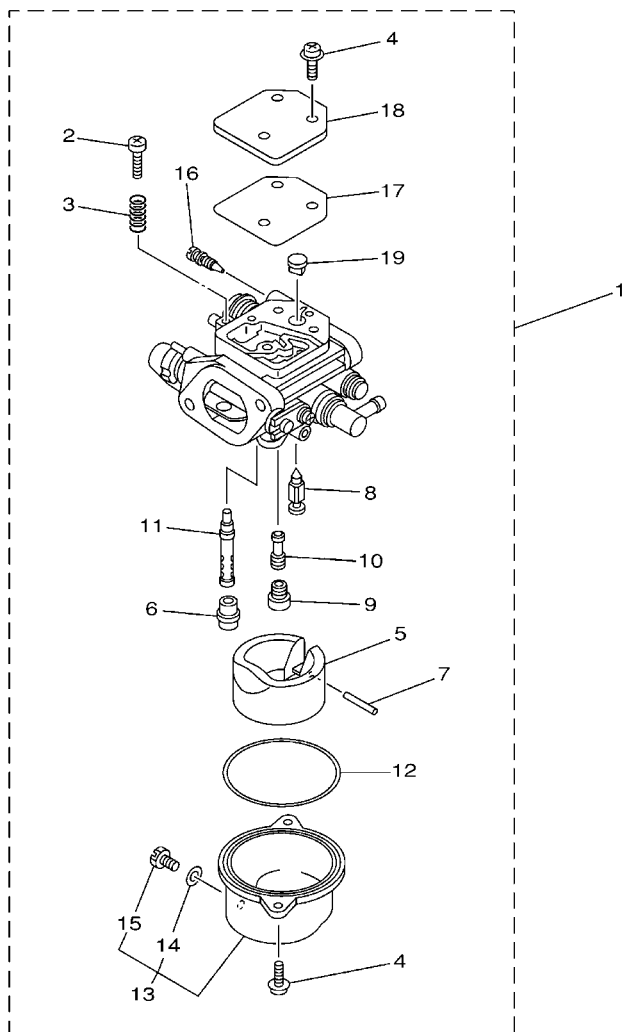

68R0010-0070

REF. NO.	PART NO. N° PIECES	DESCRIPTION DESCRIPTION	60N3	60R3		REMARKS REMARQUES
1	60N-14301-20	CARBURETOR ASSY 1 CARBURATEUR COMPLET 1	1			
	68T-14301-20	CARBURETOR ASSY 1 CARBURATEUR COMPLET 1		1		
2	6E5-14321-00	.SCREW, THROTTLE .VIS, ACCELERATEUR	1	1		
3	6J8-14334-00	.SPRING, THROTTLE .RESSORT, ACCELERATEUR	1	1		
4	97980-04112	.SCREW, WITH WASHER .VIS, AVEC RONDELLE	5	5		
5	68T-14385-00	.FLOAT .FLOTTEUR	1	1		
6	67D-14966-00	.RUBBER CAP .CAOUTCHOUC CASQUILLO	1	1		
7	67D-14386-00	.PIN, FLOAT .AXE, FLOTTEUR	1	1		
8	68T-14546-00	.VALVE, NEEDLE .POINTEAU	1	1		
9	60N-1492E-3D	.JET, MAIN (#67) .GICLEUR, PRINCIPAL (#67)	1			
	68T-1492E-37	.JET, MAIN (#74) .GICLEUR, PRINCIPAL (#74)		1		
10	60N-1492F-20	.JET, AIR SLOW (#40) .GICLEUR, AIR (#40)	1			
	68T-1492F-1K	.JET, AIR SLOW (#39) .GICLEUR, AIR (#39)		1		
11	68T-1492A-00	.NOZZLE, MAIN .PUITS D'AIGUILLE	1	1		
12	67D-14984-00	.GASKET, FLOAT CHAMBER .JOINT, CUVE DE FLOTTEUR	1	1		
13	68T-14981-00	.BODY, FLOAT CHAMBER .CORPS, CUVE DE FLOTTEUR	1	1		
14	6J8-14959-00	..GASKET ..JOINT	1	1		
15	66T-14991-00	..PLUG, DRAIN ..BOUCHON DE VIDANGE	1	1		
16	68T-14323-20	.SCREW, AIR ADJUSTING .VIS DE DOSEUR D'AIR	1	1		
17	67D-14536-00	.GASKET .JOINT	1	1		
18	67D-14527-00	.PLATE .PLAQUE	1	1		
19	68T-14126-00	.PLUG .PLOT	1	1		

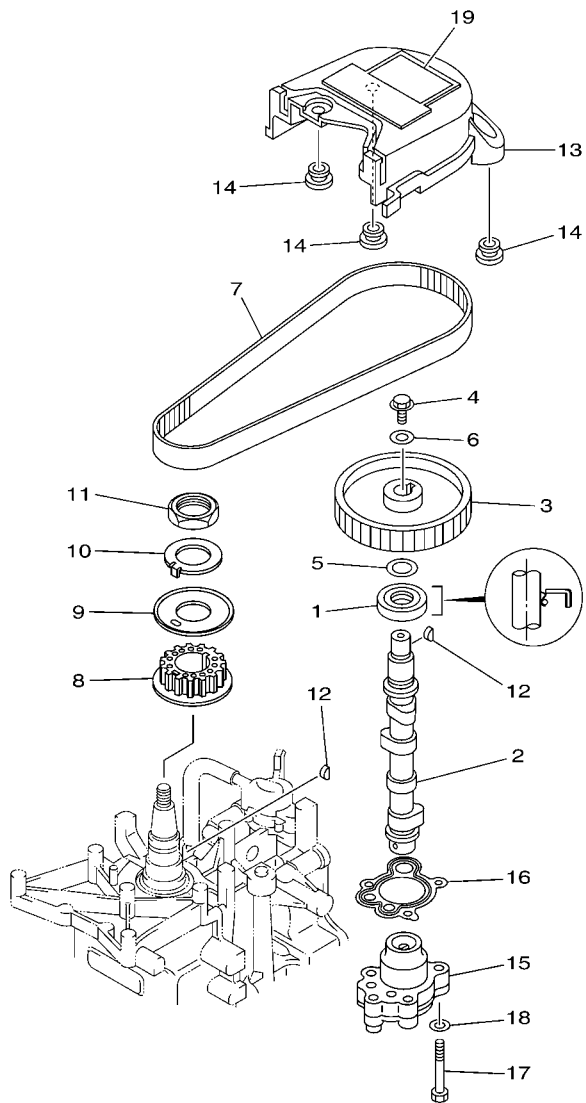

FWD
60S1300-D080

FIG. 8 OIL PUMP

POMPE A HUILE

REF. NO.	PART NO. N° PIECES	DESCRIPTION DESCRIPTION	60N3	60F3	REMARKS REMARQUES
1	93102-18M21	OIL SEAL JOINT SPY	1	1	
2	60R-E2171-00	CAMSHAFT 1 ARBRE A CAMES 1	1	1	
3	60R-E1537-00-94	GEAR, DRIVEN PIGNON SECONDAIRE	1	1	
4	90105-06M14	BOLT FLANGE BOULON	1	1	
5	90201-13201	WASHER, PLATE RONDELLE, PLATE	1	1	
6	90201-06M94	WASHER, PLATE RONDELLE, PLATE	1	1	
7	60R-G6241-00	V-BELT COURROIE TRAPEZOIDALE	1	1	
8	60R-E1536-00	GEAR, DRIVE ENGRENAGE, MENANT	1	1	
9	68T-11557-00	WASHER 1 RONDELLE 1	1	1	
10	6G8-11587-01	WASHER, LOCK RONDELLE, FREIN	1	1	
11	90170-24M09	NUT ECROU	1	1	
12	90280-03M01	KEY, WOODRUFF CLAVETTE, DEMI-LUNE	2	2	
13	60R-G6297-00	COVER, DUST COUVERCLE, POUSSIERE	1	1	
14	90480-10627	GROMMET PASSE-FIL	3	3	
15	68T-13300-00	OIL PUMP ASSY POMPE A HUILE COMPLETE	1	1	
16	68T-13329-00	GASKET, PUMP COVER JOINT, COUVERCLE DE POMPE	1	1	
17	97095-06030	BOLT BOULON	3	3	
18	92995-06600	WASHER RONDELLE	3	3	
19	60R-E2138-60	MARK, CAUTION MAKER	1	1	

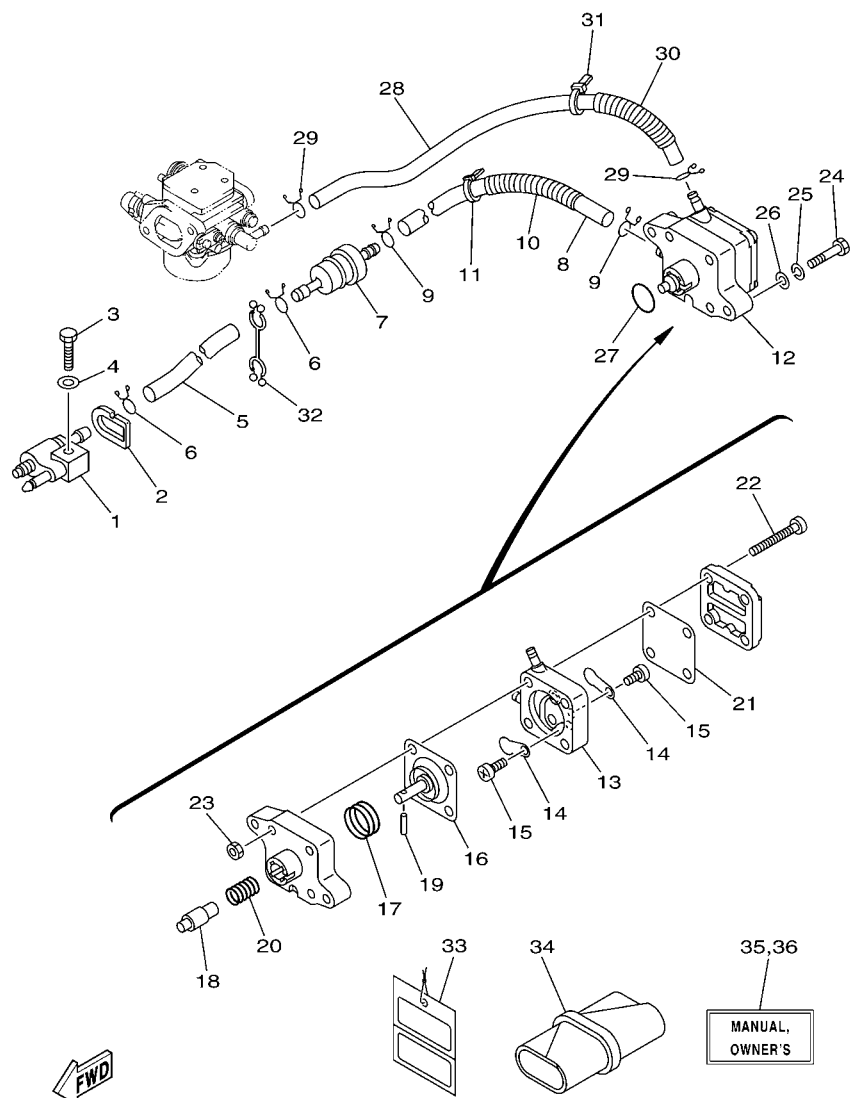

68R3300-C090

FIG. 9 FUEL

CARBURANT

REF. NO.	PART NO. N° PIECES	DESCRIPTION DESCRIPTION	60N3	60R3	REMARKS REMARQUES
1	6G1-24304-02	FUEL PIPE JOINT COMP. 1 DURITE RACCORDEMT. A ESSENCE	1	1	
2	60R-F4329-00	SEAL JOINT	1	1	
3	97095-06025	BOLT BOULON	1	1	
4	92995-06600	WASHER RONDELLE	1	1	
5	90445-10809	HOSE (L295) DURITE (L295)	1	1	
6	90467-09M09	CLIP JONC	2	2	
7	68T-24251-00	STRAINER 1 FILTRE 1	1	1	
8	90445-10811	HOSE (L170) DURITE (L170)	1	1	
9	90467-09M09	CLIP JONC	2	2	
10	90446-14M66	HOSE (L40) DURITE (L40)	1	1	
11	90465-11M10	CLAMP BRIDE	1	1	
12	68T-24410-01	FUEL PUMP ASSY POMPE A ESSENCE	1	1	
13	66M-24413-01	.BODY 2 .CORPS 2	1	1	
14	6A0-24421-01	.VALVE, CHECK .SOUPAPE, RETENUE	2	2	
15	6E7-14325-00	.SCREW, PAN HEAD .VIS TETE CONIQUE	2	2	
16	66M-24411-01	.DIAPHRAGM .DIAPHRAGME	1	1	
17	66M-24423-00	.SPRING, DIAPHRAGM .RESSORT, DIAPHRAGME	1	1	
18	66M-13131-00	.PLUNGER .PLONGEUR	1	1	
19	66M-24374-00	.PIN .GOUILLE	1	1	
20	66M-24454-00	.SPRING .RESSORT	1	1	
21	66M-24471-01	.DIAPHRAGM .DIAPHRAGME	1	1	
22	66M-24444-00	.SCREW .VIS	4	4	
23	95380-04600	.NUT .ECROU	4	4	
24	97095-06030	BOLT BOULON	2	2	
25	92995-06100	WASHER, SPRING RONDELLE, GROWER	2	2	
26	92995-06600	WASHER RONDELLE	2	2	
27	93210-20M65	O-RING JOINT TORIQUE	1	1	

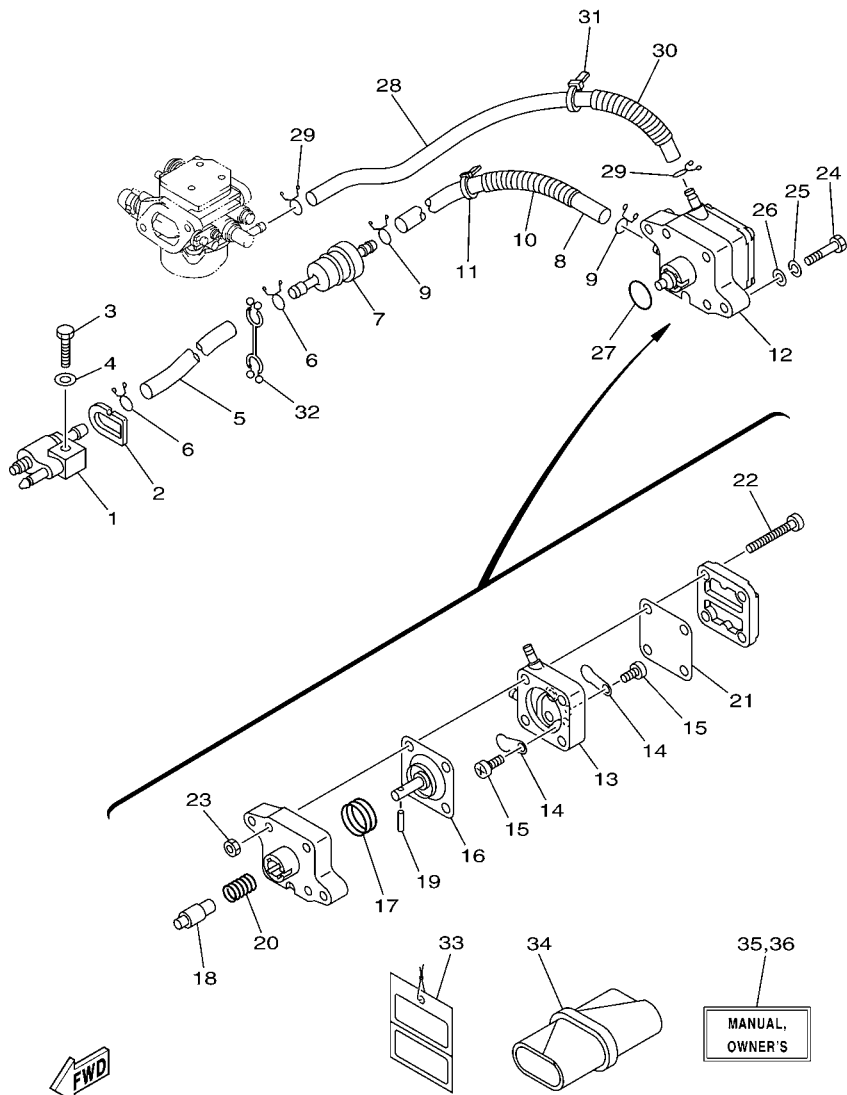

68R3300-C090

FIG. 9 FUEL

CARBURANT

REF. NO.	PART NO. N° PIECES	DESCRIPTION DESCRIPTION	60N3	60R3	REMARKS REMARQUES
28	90445-10810	HOSE (L280) DURITE (L280)	1	1	
29	90467-09M09	CLIP JONC	2	2	
30	90446-14M66	HOSE (L40) DURITE (L40)	1	1	
31	90465-11M10	CLAMP BRIDE	1	1	
32	90464-10M53	CLAMP BRIDE	1	1	
33	61H-2819R-31	TAG, WARNING ETIQUETTE, AVERTISSEMENT	1	1	
34	68T-28100-00	TOOL KIT TROUSSE A OUTILS	1	1	
35	60R-F8199-72-E0	MANUAL, OWNER'S MANUEL D'UTILISATION	1	1	UR (E) UR (E)
	60R-F8199-72-F0	MANUAL, OWNER'S MANUEL D'UTILISATION	1	1	UR (F) UR (F)
	60R-F8199-72-S0	MANUAL, OWNER'S MANUEL D'UTILISATION	1	1	UR (ES) UR (ES)
	60R-F8199-72-G0	MANUAL, OWNER'S MANUEL D'UTILISATION	1	1	UR (D) UR (D)
	60R-F8199-72-D0	MANUAL, OWNER'S MANUEL D'UTILISATION	1	1	UR (NL) UR (NL)
	60R-F8199-72-H0	MANUAL, OWNER'S MANUEL D'UTILISATION	1	1	UR (I) UR (I)
36	60R-F8199-82-K0	MANUAL, OWNER'S MANUEL D'UTILISATION	1	1	UR (DK) UR (DK)
	60R-F8199-82-R0	MANUAL, OWNER'S MANUEL D'UTILISATION	1	1	UR (GR) UR (GR)
	60R-F8199-82-P0	MANUAL, OWNER'S MANUEL D'UTILISATION	1	1	UR (P) UR (P)
	60R-F8199-82-N0	MANUAL, OWNER'S MANUEL D'UTILISATION	1	1	UR (N) UR (N)
	60R-F8199-82-M0	MANUAL, OWNER'S MANUEL D'UTILISATION	1	1	UR (S) UR (S)
	60R-F8199-82-L0	MANUAL, OWNER'S MANUEL D'UTILISATION	1	1	UR (SF) UR (SF)

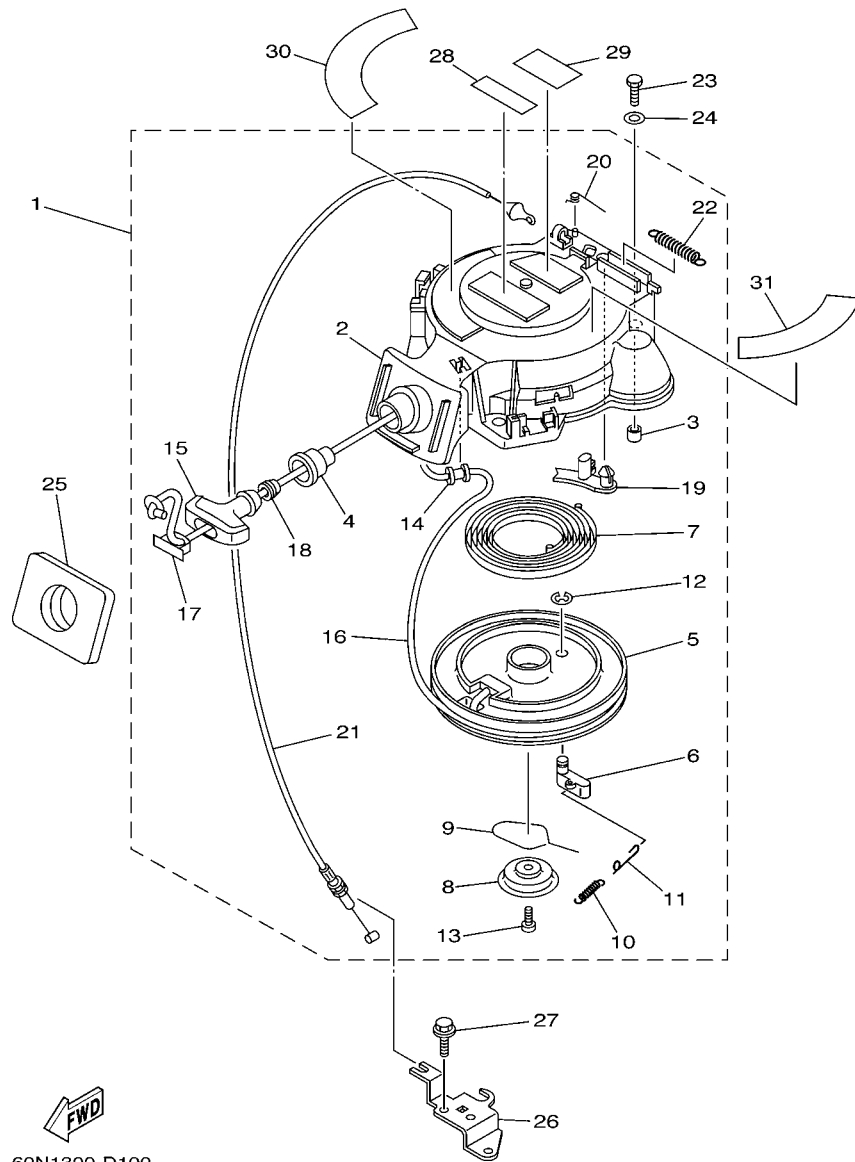

60N1300-D100

*1: CUT FROM 50M ROLLS, PART NO. 90890-44373, CUTTING LENGTH 1.8M

*1: A PRELEVER SUR BOBINE 50M, REFERENCE 90890-44373, LONGUEUR DE COUPE 1.8M

FIG. 10 STARTER

DEMARREUR

REF. NO.	PART NO. N° PIECES	DESCRIPTION DESCRIPTION	60N3	60R3	REMARKS REMARQUES
1	68T-15710-11	STARTER ASSY DEMARREUR COMPLET	1	1	
2	68T-15711-02	.CASE, STARTER .CARTER DE DEMARREUR	1	1	
3	67D-15764-00	.COLLAR 1 .COLLERETTE 1	3	3	
4	68T-15795-00	.GUIDE, ROPE .GUIDE DE CABLE	1	1	
5	63V-15714-00	.DRUM, SHEAVE .TAMBOUR, POULIE	1	1	
6	63V-15741-00	.PAWL, DRIVE .CLIQUET, ENTRAINEMENT	1	1	
7	63V-15713-00	.SPRING, STARTER .RESSORT DE DEMARREUR	1	1	
8	68T-15716-00	.PLATE, DRIVE .PLAQUE, ENTRAINEMENT	1	1	
9	63V-15705-01	.SPRING, DRIVE PAWL .RESSORT DE CLIQUET	1	1	
10	63V-15767-01	.SPRING .RESSORT	1	1	
11	68T-15784-00	.SPRING, RETURN .RESSORT, RAPPEL	1	1	
12	63V-15744-00	.CIRCLIP .CIRCLIP	1	1	
13	68T-15793-00	.SCREW .VIS	1	1	
14	68T-15764-00	.COLLAR 1 .COLLERETTE 1	1	1	
15	6G1-15755-00	.HANDLE, STARTER .POIGNEE, DE DEMARREUR	1	1	
16	*	.WIRE, STARTER (L:1800MM) .CABLE DE DEMARREUR (L:1800MM)	1	1	*1 *1
17	6G1-15779-00	.COVER .COUVERCLE	1	1	
18	6A0-15789-00	.DAMPER .AMORTISSEUR	1	1	
19	68T-15794-00	.STOPPER .BUTEE	1	1	
20	66T-15734-00	.SPRING, RETURN .RESSORT, RAPPEL	1	1	
21	68T-15770-00	.CABLE COMP., STARTER STOP .CABLE, BUTEE DE DEMAR	1	1	
22	66T-15731-00	.SPRING, RETURN .RESSORT, RAPPEL	1	1	
23	97095-06020	BOLT BOULON	3	3	
24	92995-06600	WASHER RONDELLE	3	3	
25	68T-15762-00	SEAL, RUBBER 2 JOINT CAOUTCHOUC 2	1	1	
26	68T-15774-10	STAY 4 SUPPORT 4	1	1	
27	90109-06M86	BOLT BOULON	2	2	

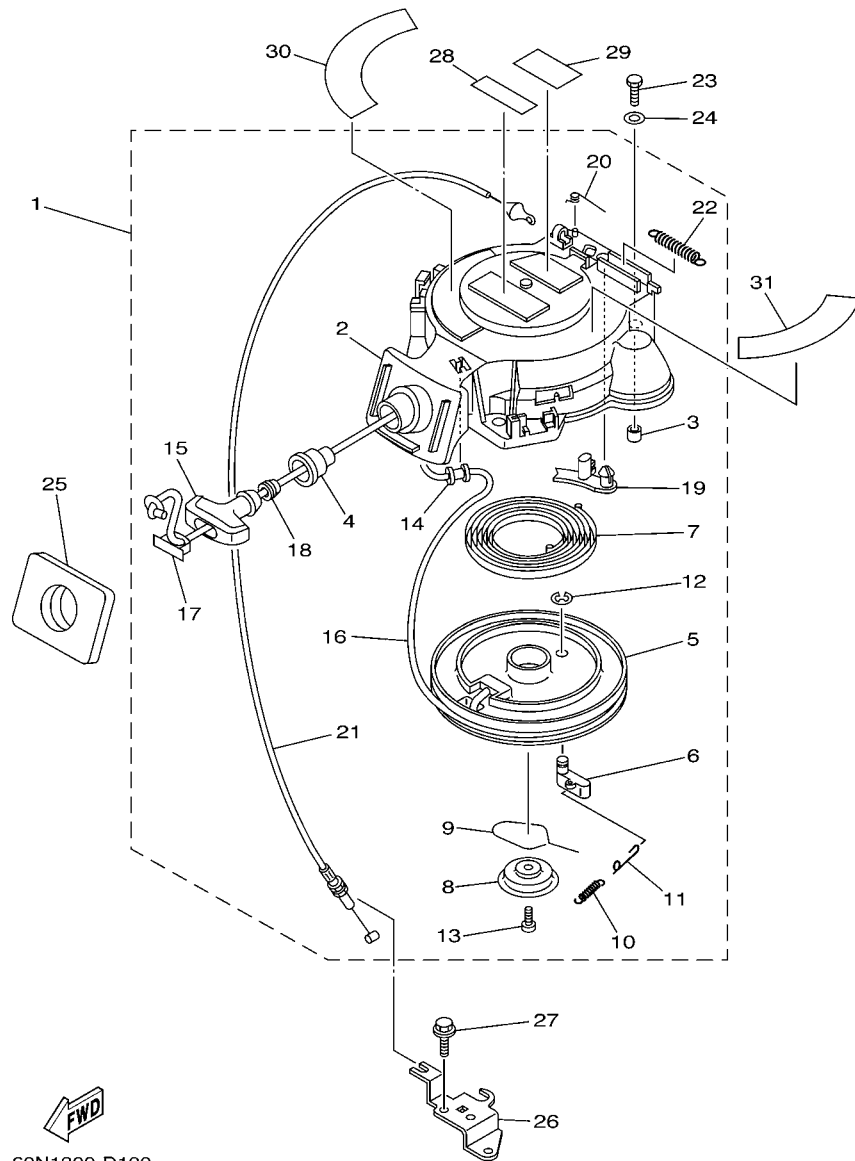

60N1300-D100

*1: CUT FROM 50M ROLLS, PART NO.90890-44373, CUTTING LENGTH 1.8M

*1:A PRELEVER SUR BOBINE 50M ,REFERENCE 90890-44373, LONGUEUR DE COUPE 1.8M

FIG. 10 STARTER

DEMARREUR

REF. NO.	PART NO. N° PIECES	DESCRIPTION DESCRIPTION	60N3	60R3				REMARKS REMARQUES
28	60R-H3625-40	MARK 5 ETIQUETTE 5	1	1				
29	60R-H3625-50	MARK 5 ETIQUETTE 5	1	1				
30	60R-E3437-61	MARK, CAUTION MAKER	1	1				
31	60R-H5711-60	MARK, CAUTION MAKER	1	1				

FIG. 12 ELECTRICAL 1

PARTIE ELECTRIQUE 1

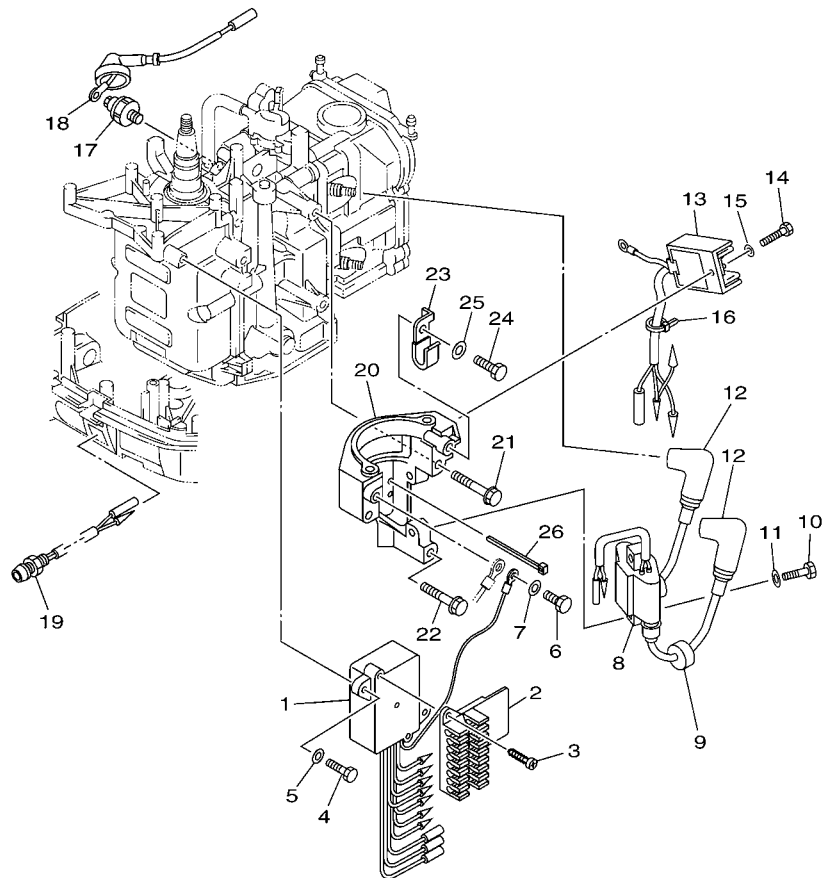

60N1300-D120

REF. NO.	PART NO. N° PIECES	DESCRIPTION DESCRIPTION	60N3	60R3		REMARKS REMARQUES
1	68R-85540-00	C.D.I. UNIT ASSY BLOC C.D.I.	1			
	68T-85540-00	C.D.I. UNIT ASSY BLOC C.D.I.		1		
2	68T-82522-00	CLAMP, COUPLER BRIDE, DE CONNECTEUR	1	1		
3	97780-40512	SCREW, TAPPING VIS, TETE BOMBEE	2	2		
4	97095-06020	BOLT BOULON	2	2		
5	92995-06600	WASHER RONDELLE	2	2		
6	97095-06012	BOLT BOULON	1	1		
7	92995-06600	WASHER RONDELLE	1	1		
8	680-85570-01	IGNITION COIL ASSY BOBINE D'ALLUMAGE (ENS.)	1	1		
9	90480-25161	GROMMET PASSE-FIL	2	2		
10	97095-06025	BOLT BOULON	2	2		
11	92995-06600	WASHER RONDELLE	2	2		
12	6E3-82370-21	PLUG CAP ASSY ANTIPARASITE	2	2		
13	68T-81960-00	RECTIFIER & REGULATOR ASSY REDRESSEUR REGULATEUR CPLT	1	1		
14	97095-06012	BOLT BOULON	1	1		
15	92995-06600	WASHER RONDELLE	1	1		
16	90465-11M10	CLAMP BRIDE	1	1		
17	67F-82504-00	OIL PRESSURE SWITCH ASSY CONTACTEUR DE PRESSION D'HUILE	1	1		
18	68T-82127-10	WIRE, LEAD 2 FIL 2	1	1		
19	68T-85410-00	EMERGENCY SIGNAL LIGHT ASSY FEU DE DETRESSE	1	1		
20	68T-81822-00-94	BRACKET, STARTING MOTOR SUPPORT, DEMARREUR ELECTRIQUE	1	1		
21	90119-08046	BOLT, WITH WASHER BOULON, AVEC RONDELLE	2	2		
22	90119-08020	BOLT, WITH WASHER BOULON, AVEC RONDELLE	1	1		
23	90465-08M99	CLAMP BRIDE	1	1		
24	97095-06012	BOLT BOULON	1	1		
25	92995-06600	WASHER RONDELLE	1	1		
26	90465-11M10	CLAMP BRIDE	1	1		

FIG. 13 ELECTRICAL 2

PARTIE ELECTRIQUE 2

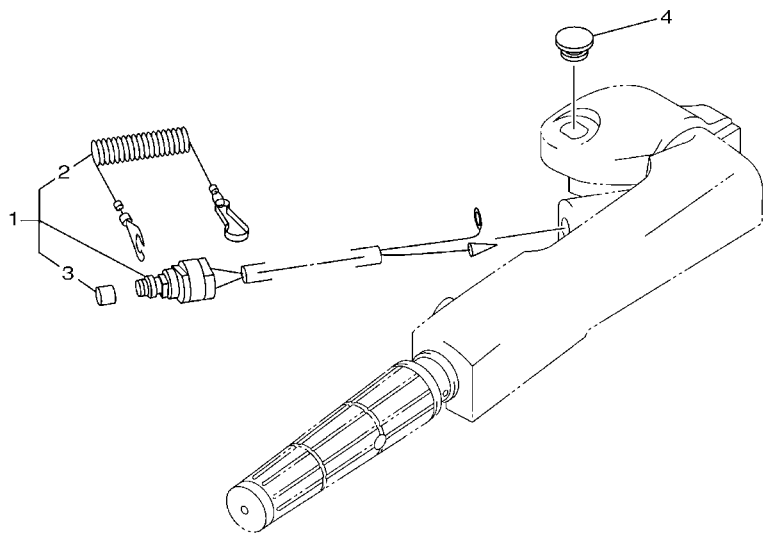

REF. NO.	PART NO. N° PIECES	DESCRIPTION DESCRIPTION	60N3	60F3			REMARKS REMARQUES
1	65W-82575-01	ENGINE STOP SWITCH ASSY COUPE CIRCUIT CPLT	1	1			
2	682-82556-00	.LANYARD, STOP SWITCH .PLAQUETTE	1	1			
3	689-8257Y-00	.CAP .CHAPEAU	1	1			
4	6G1-42725-00	GROMMET PASSE-FIL	1	1			

68R0100-0130

FIG. 14 BOTTOM COWLING

CAPOT INFERIEUR

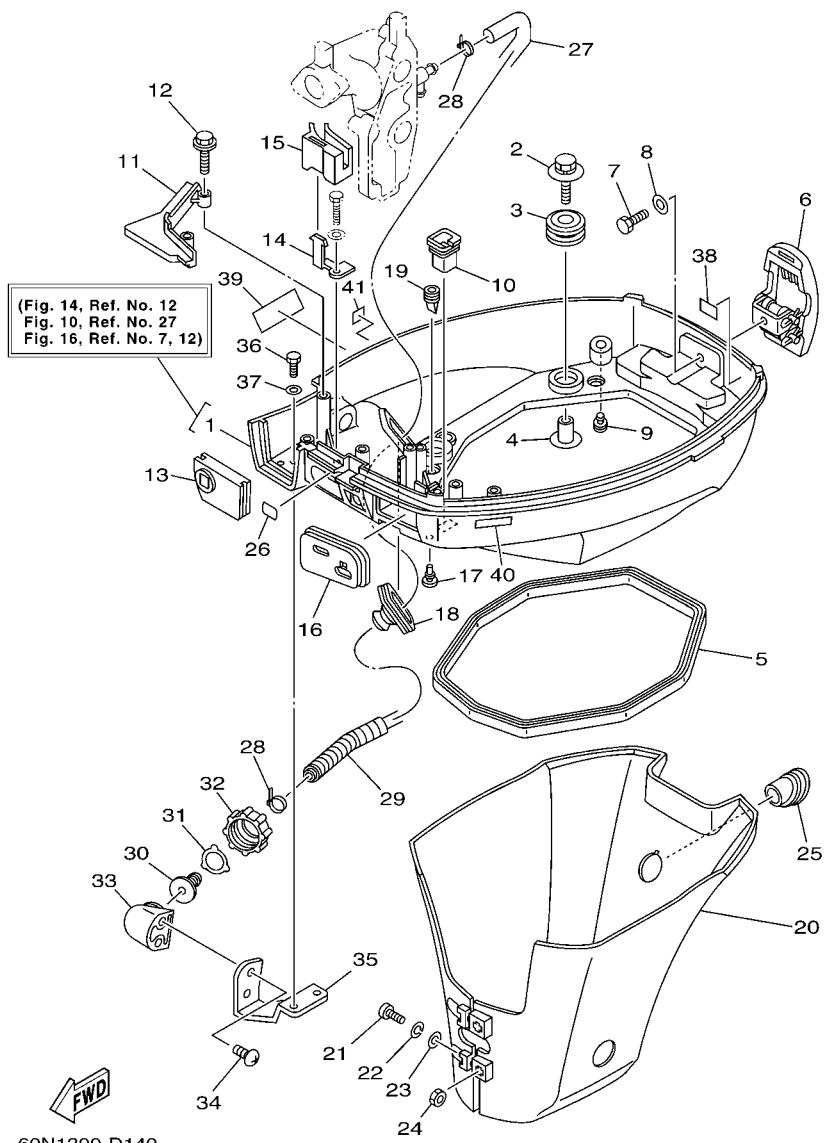

60N1300-D140

REF. NO.	PART NO. N° PIECES	DESCRIPTION DESCRIPTION	60N3	60R3	REMARKS REMARQUES
1	60R-G2710-00-4D	BOTTOM COWLING ASSY ENS. EMBASE	1	1	WITH TAPPING BOLT WITH TAPPING BOLT
2	68F-85119-00	BOLT BOULON	4	4	
3	90480-21M82	GROMMET PASSE-FIL	4	4	
4	90387-06053	COLLAR COLLERETTE	4	4	
5	68T-42716-10	RUBBER, SEAL 1 JOINT EN CAOUTCHOUC 1	1	1	
6	68T-42801-00	COWLING CLAMP COMP. BRIDE DE CAPOT COMP.	1	1	
7	97095-06012	BOLT BOULON	1	1	
8	92995-06600	WASHER RONDELLE	1	1	
9	6H3-44391-01	NIPPLE, HOSE RACCORD D'ESSENCE	1	1	
10	682-42727-00	GROMMET PASSE-FIL	1	1	
11	68T-42738-00-4D	PLATE, FITTING ETRIER	1	1	
12	90109-06M81	BOLT BOULON	2	2	
13	68T-42725-00	GROMMET PASSE-FIL	1	1	
14	68T-26393-00	HOLDER SUPPORT	1	1	
15	68T-26367-00	PROTECTOR PROTECTEUR	1	1	
16	60R-G2724-00	GROMMET PASSE-FIL	1	1	
17	90480-06M19	GROMMET PASSE-FIL	1	1	
18	688-42726-10	GROMMET PASSE-FIL	1	1	FLUSHING KIT FLUSHING KIT
19	60S-G2717-00	RUBBER, SEAL 2 JOINT EN CAOUTCHOUC 2	2	2	
20	60R-G2741-00	APRON CAPOT LATERAL	1	1	
21	97885-06030	SCREW, PAN HEAD VIS, A ENCOCHE	2	2	
22	92995-06100	WASHER, SPRING RONDELLE, GROWER	2	2	
23	92995-06600	WASHER RONDELLE	2	2	
24	95380-06600	NUT, HEXAGON ECROU	2	2	
25	68T-42717-00	RUBBER, SEAL 2 JOINT EN CAOUTCHOUC 2	1	1	
26	60R-H4342-00	SEAT, EMBLEM SIEGE, EMBLEME	1	1	
27	60S-E2481-00	PIPE 1 DURITE 1	1	1	FLUSHING KIT FLUSHING KIT

FIG. 14 BOTTOM COWLING

CAPOT INFERIEUR

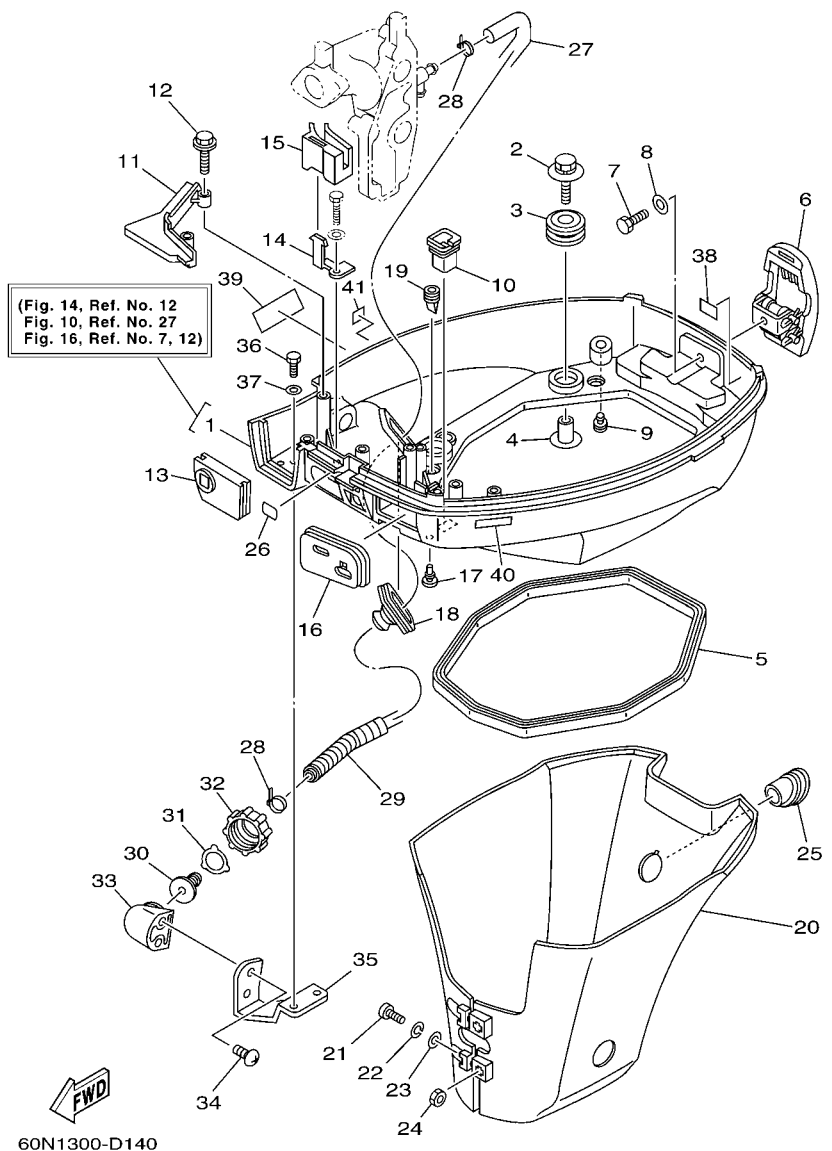

60N1300-D140

REF. NO.	PART NO. N° PIECES	DESCRIPTION DESCRIPTION	60N3	60R3	REMARKS REMARQUES
28	90465-11M10	CLAMP BRIDE	2	2	FLUSHING KIT FLUSHING KIT
29	90447-13M00	HOSE, WITH SPRING DURITE, AVEC RESSORT	1	1	FLUSHING KIT FLUSHING KIT
30	6R3-12582-00	JOINT, HOSE 2 RACCORD DE TUYAU 1	1	1	FLUSHING KIT FLUSHING KIT
31	6R3-12583-00	GASKET, HOSE JOINT JOINT	1	1	FLUSHING KIT FLUSHING KIT
32	6R3-12581-00	JOINT, HOSE 1 JOINT DE TUYAU	1	1	FLUSHING KIT FLUSHING KIT
33	68T-12572-00	ADAPTER ADAPTATEUR	1	1	FLUSHING KIT FLUSHING KIT
34	90167-06002	SCREW, TAPPING VIS, TETE FRAISEE	2	2	FLUSHING KIT FLUSHING KIT
35	68T-12535-00	PLATE PLAQUE	1	1	FLUSHING KIT FLUSHING KIT
36	97095-06010	BOLT BOULON	2	2	FLUSHING KIT FLUSHING KIT
37	92995-06600	WASHER RONDELLE	2	2	FLUSHING KIT FLUSHING KIT
38	6H8-42791-10	MARK 1 ETIQUETTE 1	1	1	
39	60R-E3444-50	MARK MAKER	1	1	
40	68D-H257H-00	PLATE, MARK PLAQUE, ADHESIF	1	1	
41	6N0-F8176-00	LABEL, CAUTION ETIQUETTE, RECOMMANDATION	1	1	

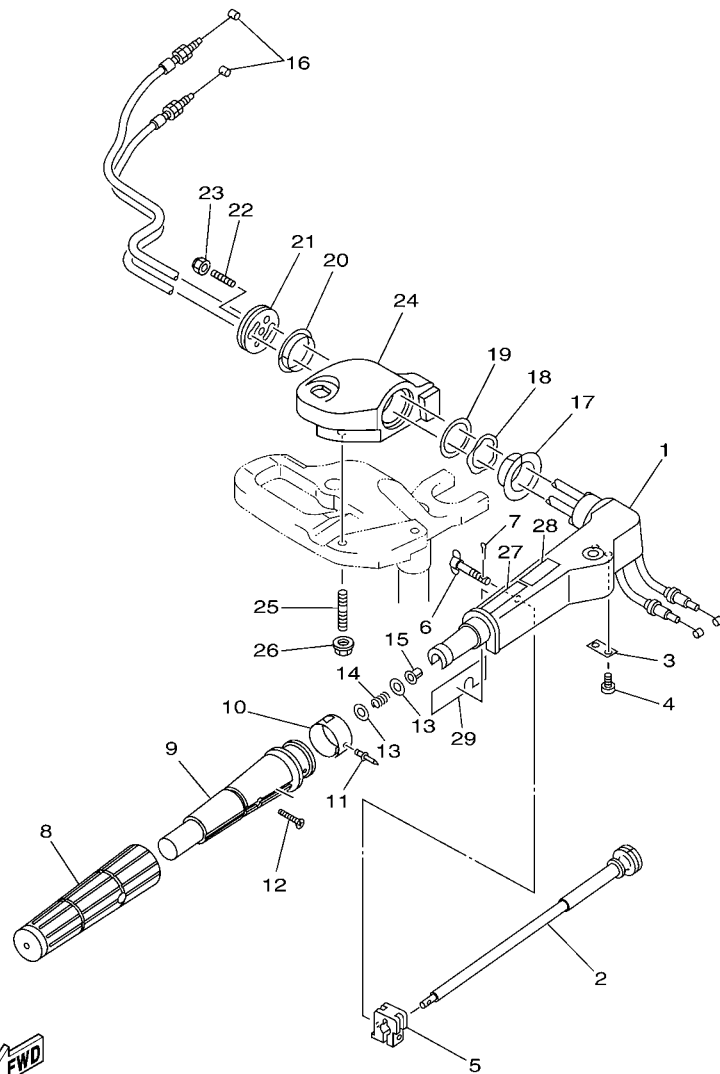

60N3300-F150

FIG. 15 STEERING

DIRECTION

REF. NO.	PART NO. N° PIECES	DESCRIPTION DESCRIPTION	60N3	60R3	REMARKS REMARQUES
1	60R-G2111-00-4D	HANDLE, STEERING POIGNEE	1	1	
2	6G1-42138-01	LEVER, THROTTLE LEVIER, ACCELERATEUR	1	1	
3	68D-G2159-00	STAY SUPPORT	1	1	
4	97885-05012	SCREW, PAN HEAD VIS, A ENCOCHE	2	2	
5	6G1-42126-00	FRICTION, STEERING HANDLE GRIP CUVETTE, POIGNEE DE DIRECTION	1	1	
6	6G1-42125-01	BOLT, FRICTION ADJUSTING BOULON	1	1	
7	91490-16010	PIN, COTTER GOUPILLE	1	1	
8	68D-G2177-10	RUBBER, HANDLE CAOUTCHOUC, POIGNEE	1	1	
9	68D-G2119-00	GRIP, STEERING HANDLE POIGNEE, BARRE FRANCHE	1	1	
10	60N-G2137-00	INDICATOR, THROTTLE INDICATEUR, ACCELERATION	1		
	60R-G2137-00	INDICATOR, THROTTLE INDICATEUR, ACCELERATION		1	
11	90269-02M09	RIVET RIVET	1	1	
12	90149-05M13	SCREW VIS	1	1	
13	90201-10M02	WASHER, PLATE RONDELLE, PLATE	2	2	
14	90501-23800	SPRING, COMPRESSION RESSORT, COMPRESSION	1	1	
15	90386-08032	BUSH DOUILLE	1	1	
16	68T-26301-01	THROTTLE CABLE ASSY CABLE D'ACCELERATEUR	2	2	
17	90386-34M97	BUSH DOUILLE	1	1	
18	90206-36M21	WASHER, WAVE RONDELLE, ONDULEE	1	1	
19	90202-36M55	WASHER, PLATE RONDELLE, PLATE	1	1	
20	90386-33M96	BUSH DOUILLE	1	1	
21	68T-42131-01	COVER, HANDLE STEERING COUVERCLE	1	1	
22	90116-08015	BOLT, STUD GOUJON	1	1	
23	90185-08057	NUT, SELF-LOCKING ECROU, AUTO-BLOQUANT	1	1	
24	60R-G2121-00-4D	BRACKET SUPPORT	1	1	
25	90116-10019	BOLT, STUD GOUJON	2	2	
26	90179-10M33	NUT ECROU	2	2	

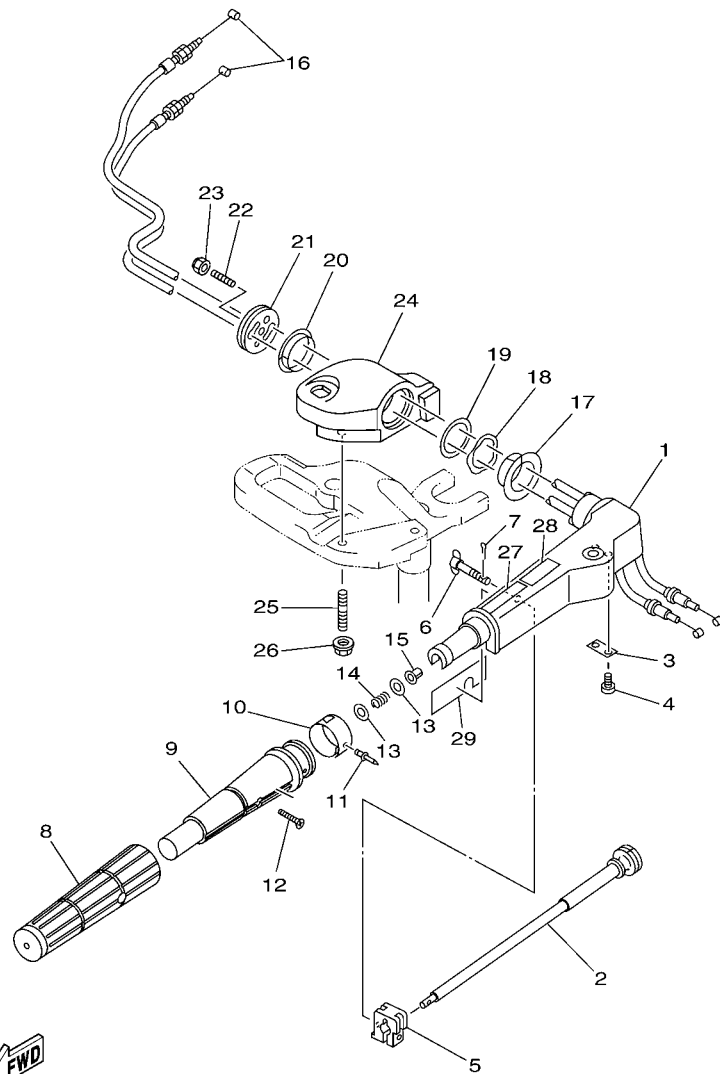

60N3300-F150

FIG. 15 STEERING

DIRECTION

REF. NO.	PART NO. N° PIECES	DESCRIPTION DESCRIPTION	DIRECTION		REMARKS REMARQUES
			60N3	60R3	
27	60R-H3627-40	LABEL, CAUTION 7 ETIQUETTE, RECOMMANDATION 7	1	1	
28	60R-H3627-50	LABEL, CAUTION 7 ETIQUETTE, RECOMMANDATION 7	1	1	
29	60R-E571Y-60	MARK, CAUTION MAKER	1	1	

D1

FIG. 16 CONTROL

COMMANDE

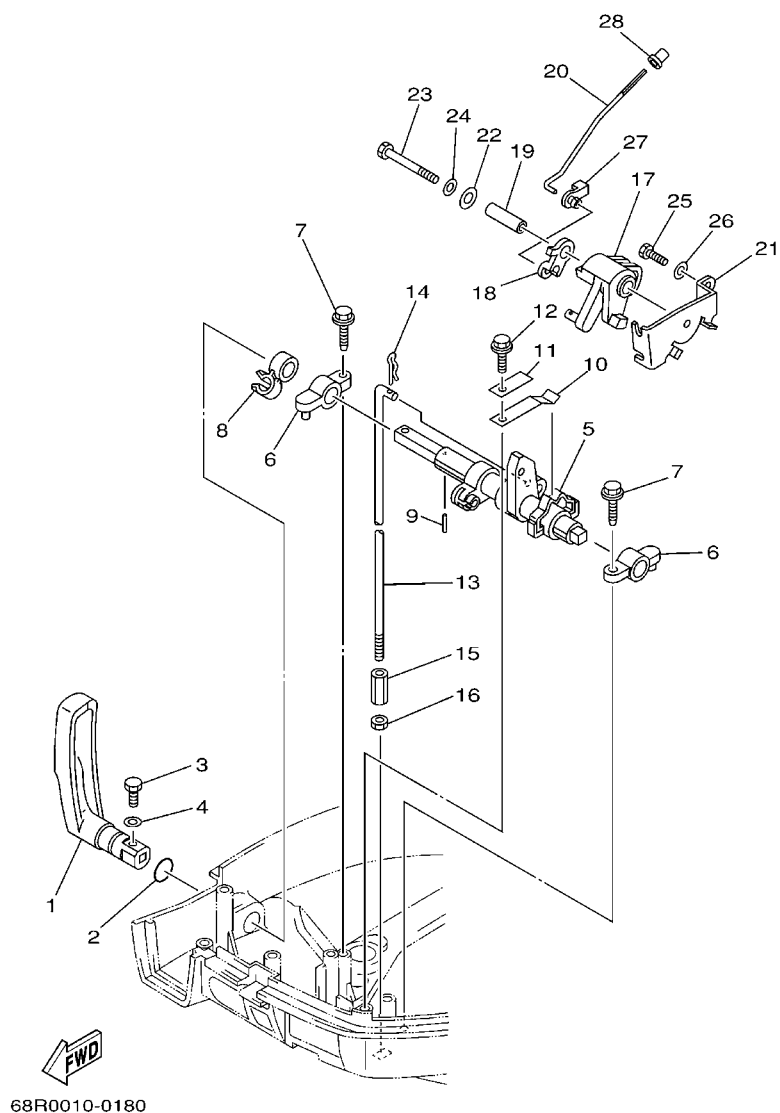

68R0010-0180

REF. NO.	PART NO. N° PIECES	DESCRIPTION DESCRIPTION	60N3	60R3	REMARKS REMARQUES
1	60R-G4111-00	HANDLE, GEAR SHIFT POIGNEE, LEVIER D'EMBRAYAGE	1	1	
2	93210-12327	O-RING JOINT TORIQUE	1	1	
3	97095-05016	BOLT BOULON	1	1	
4	92995-05600	WASHER RONDELLE	1	1	
5	68T-44121-01	LEVER, SHIFT ROD LEVIER, TIGE D'INVERSION	1	1	
6	6G1-41662-01-94	BRACKET SUPPORT	2	2	
7	90109-06M81	BOLT BOULON	2	2	
8	90464-10M60	CLAMP BRIDE	1	1	
9	91690-30014	PIN, SPRING AGRAFFE	1	1	
10	65W-44116-00	SPRING RESSORT	1	1	
11	66R-44114-00	STOPPER PLAQUETTE	1	1	
12	90109-06M86	BOLT BOULON	1	1	
13	60R-G4143-00 60R-G4143-10	ROD, SHIFT TIGE D'EMBRAYAGE ROD, SHIFT TIGE D'EMBRAYAGE	1	1	S(17.1") S(17.1") L(22.1") L(22.1")
14	90468-18001	CLIP JONC	1	1	
15	90170-06015	NUT ECROU	1	1	
16	95380-06700	NUT ECROU	1	1	
17	68T-41638-00	PULLEY POULIE	1	1	
18	68R-41283-00 68T-41283-00	LEVER, FREE ACCEL. LEVIER LEVER, FREE ACCEL. LEVIER	1	1	
19	90387-06M59	COLLAR COLLERETTE	1	1	
20	68T-41211-00	LINK, ACCEL. BIELLETTE, ACCELERATION	1	1	
21	68T-14497-00	STAY, THROTTLE WIRE SUPPORT DE BOISSEAU	1	1	
22	90201-06M62	WASHER, PLATE RONDELLE, PLATE	1	1	
23	97095-06045	BOLT BOULON	1	1	
24	92995-06600	WASHER RONDELLE	1	1	
25	97095-06012	BOLT BOULON	1	1	

FIG. 16 CONTROL

COMMANDE

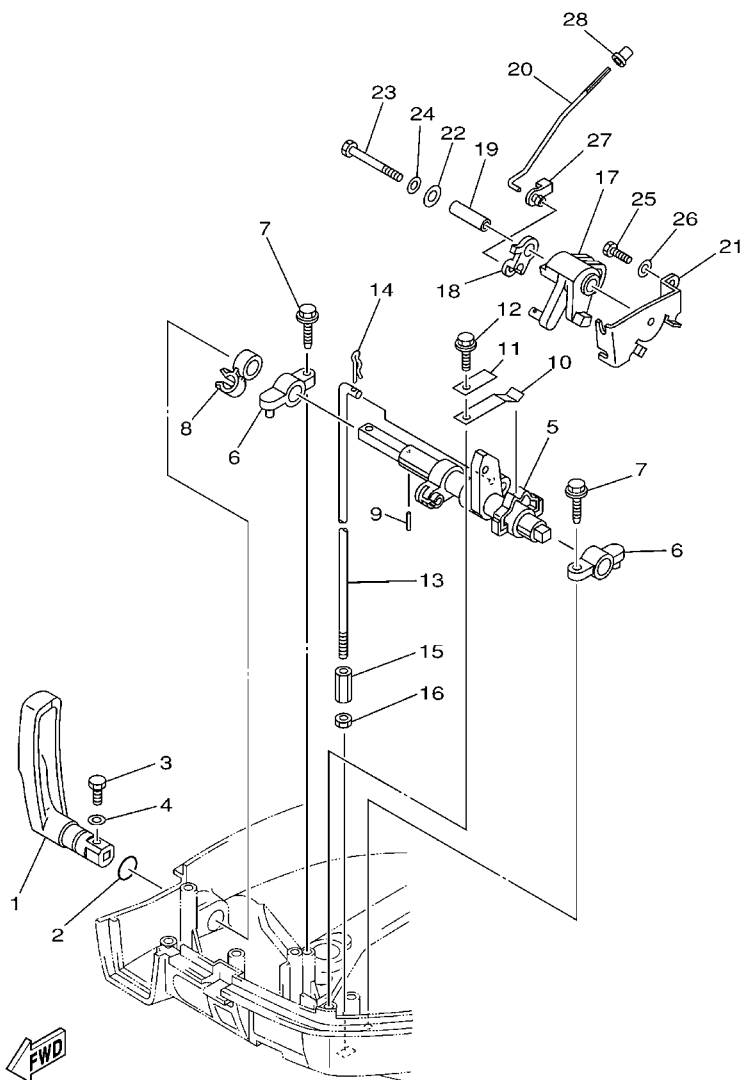

68R0010-0180

REF. NO.	PART NO. N° PIECES	DESCRIPTION DESCRIPTION	60N3	60F3		REMARKS REMARQUES
26	92995-06600	WASHER RONDELLE	1	1		
27	661-41262-02	JOINT, CHOKE LEVER RACCORD, LEVIER DE STARTER	1	1		
28	647-14395-60	CAP, OVERFLOW PIPE COUVRE DE DURITE REFOULEMENT	1	1		

FIG. 17 REMO CON ATTACHMENT

COMMANDE A DISTANCE

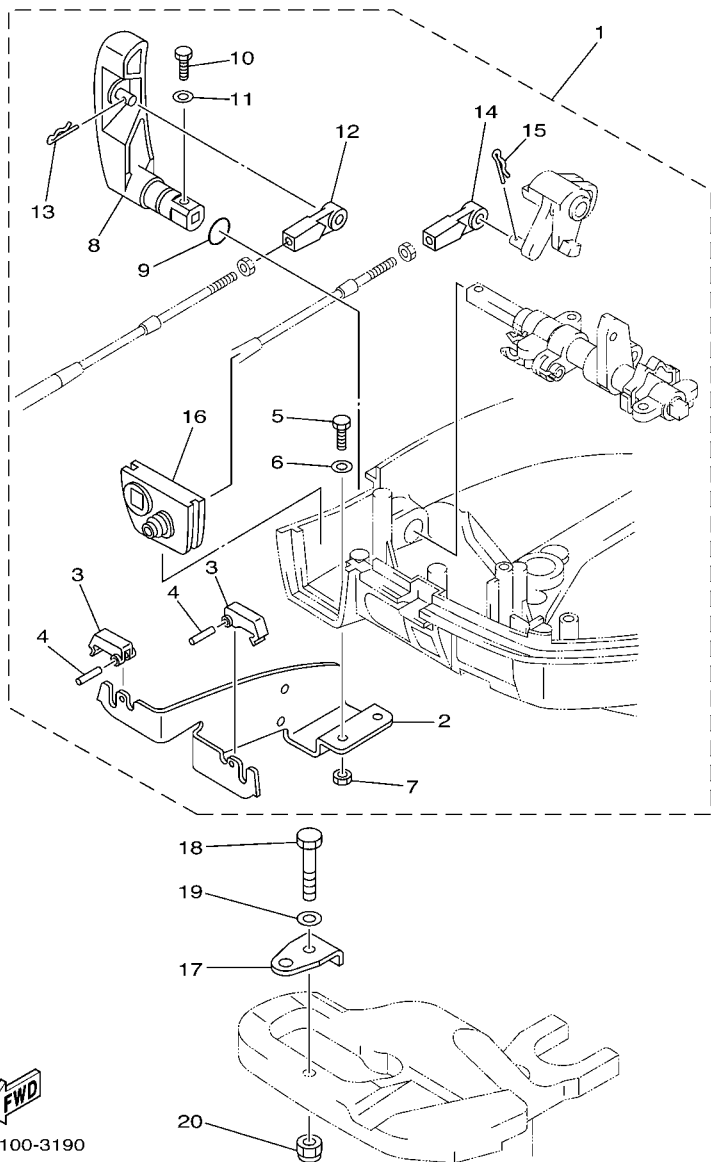

68R2100-3190

REF. NO.	PART NO. N° PIECES	DESCRIPTION DESCRIPTION	60N3	60R3		REMARKS REMARQUES
1	60R-G8501-00	REMOTE CONT. ATTACHMENT ASSY. COMMANDE A DISTANCE (KIT)	1	1		AP AP
2	68T-48531-00	.BRACKET, REMOTE CONTROL 1 .ETRIER 1, COMMANDE A DISTANCE	1	1		
3	682-48538-50	.CLAMP, CABLE 1 .COLLIER	2	2		
4	91690-30012	.PIN, SPRING .AGRAFFE	2	2		
5	97095-06012	.BOLT .BOULON	2	2		
6	92995-06600	.WASHER .RONDELLE	2	2		
7	95380-06600	.NUT, HEXAGON .ECROU	2	2		
8	60R-G4111-10	.HANDLE, GEAR SHIFT .POIGNEE, LEVIER D'EMBRAYAGE	1	1		
9	93210-12327	.O-RING .JOINT TORIQUE	1	1		
10	97095-05016	.BOLT .BOULON	1	1		
11	92995-05600	.WASHER .RONDELLE	1	1		
12	663-48344-00	.CABLE END, REMOTE CONTROL .CHAPE CABLE	1	1		
13	90468-18008	.CLIP .JONC	1	1		
14	663-48344-00	.CABLE END, REMOTE CONTROL .CHAPE CABLE	1	1		
15	90468-18008	.CLIP .JONC	1	1		
16	68T-42725-10	.GROMMET .PASSE-FIL	1	1		
17	63V-48511-01	HOOK, STEERING ATTACHE, DIRECTION		1		AP AP
18	97075-08035	BOLT BOULON		1		AP AP
19	92995-08600	WASHER RONDELLE		1		AP AP
20	90185-08057	NUT, SELF-LOCKING ECROU,AUTO-BLOQUANT		1		AP AP

FIG. 18 BRACKET 1

SUPPORT 1

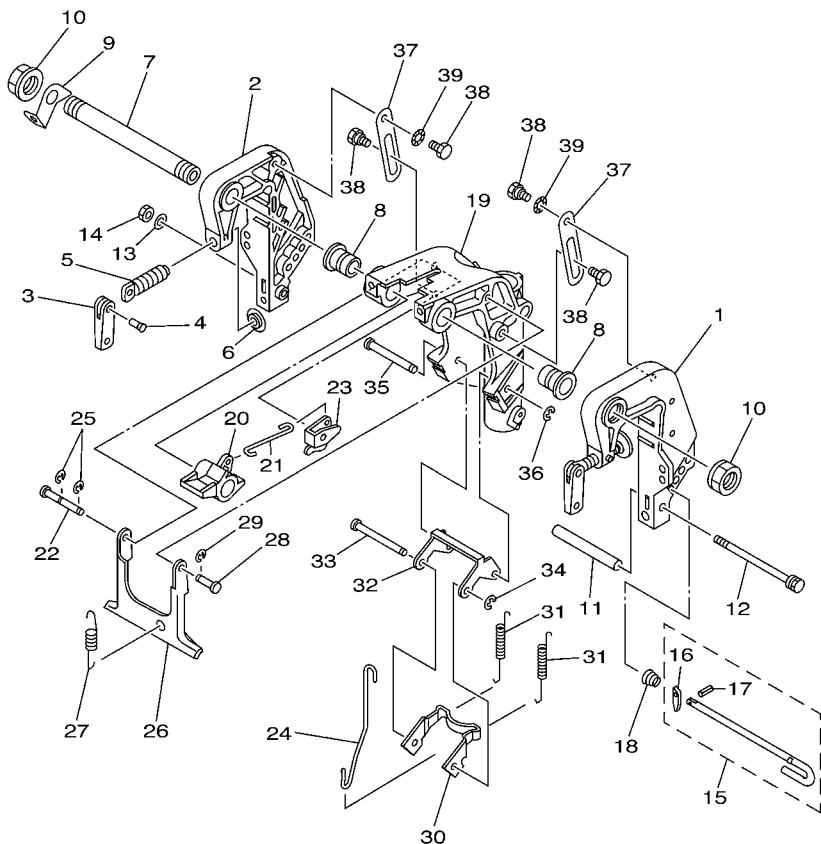

FWD
68R3110-C200

REF. NO.	PART NO. N° PIECES	DESCRIPTION DESCRIPTION	60N3	60R3	REMARKS REMARQUES
1	60R-G3111-00-4D	BRACKET, CLAMP 1 PRESSE 1	1	1	
2	60R-G3112-00-4D	BRACKET, CLAMP 2 PRESSE 2	1	1	
3	6L8-G3118-01	HANDLE, TRANSOM CLAMP POIGNEE DE VIS DE PRESSE	2	2	
4	90243-04M01	PIN GOUPILLE	2	2	
5	6E7-43116-00	SCREW, TRANSOM CLAMP VIS DE PRESSE	2	2	
6	648-43114-01	PAD, TRANSOM CLAMP RONDELLE D'APPUI	2	2	
7	63V-43131-10	BOLT, CLAMP BRACKET (L:283MM) BOULON, PRESSE (L:283MM)	1	1	FOR RIDE GUIDE FOR RIDE GUIDE
8	90386-22MA4	BUSH DOUILLE	2	2	
9	66R-43113-00	PLATE, CLAMP BRACKET PLAQUETTE, PRESSE	1	1	
10	90185-22043	NUT, SELF-LOCKING ECROU, AUTO-BLOQUANT	2	2	
11	90387-06M13	COLLAR COLLERETTE	1	1	
12	90101-06M18	BOLT BOULON	1	1	
13	92990-06600	WASHER, PLATE RONDELLE, PLATE	1	1	
14	95380-06700	NUT ECROU	1	1	
15	6L2-43160-01	TILT ROD ASSY BROCHE D'INCLINAISON (ENS.)	1	1	
16	689-43165-00	.PLATE, TILT LOCK .TAQUET, BROCHE INCLINAISON	1	1	
17	91690-30008	.PIN, SPRING .AGRAFFE	1	1	
18	90502-10M07	SPRING, CONICAL RESSORT, CONIQUE	1	1	
19	60R-G3311-00-4D	BRACKET, SWIVEL 1 SUPPORT, PIVOT 1	1	1	S(17.1") S(17.1")
	60R-G3311-10-4D	BRACKET, SWIVEL 1 SUPPORT, PIVOT 1	1	1	L(22.1") L(22.1")
20	60R-G3631-00	LEVER, TILT LEVIER, INCLINAISON	1	1	
21	60R-G3616-00	ROD, TILT LOCK TIGE	1	1	
22	68T-43646-00	SHAFT, LEVER AXE, LEIVER	1	1	
23	68T-43641-00	LEVER, TILT LEVIER, INCLINAISON	1	1	
24	68T-43617-00	ROD, TILT LOCK TIGE	1	1	
25	99080-05600	CIRCLIP CIRCLIP	2	2	
26	68T-43350-00	RECEIVER ASSY RECEIVER ASSY	1	1	

FIG. 18 BRACKET 1

SUPPORT 1

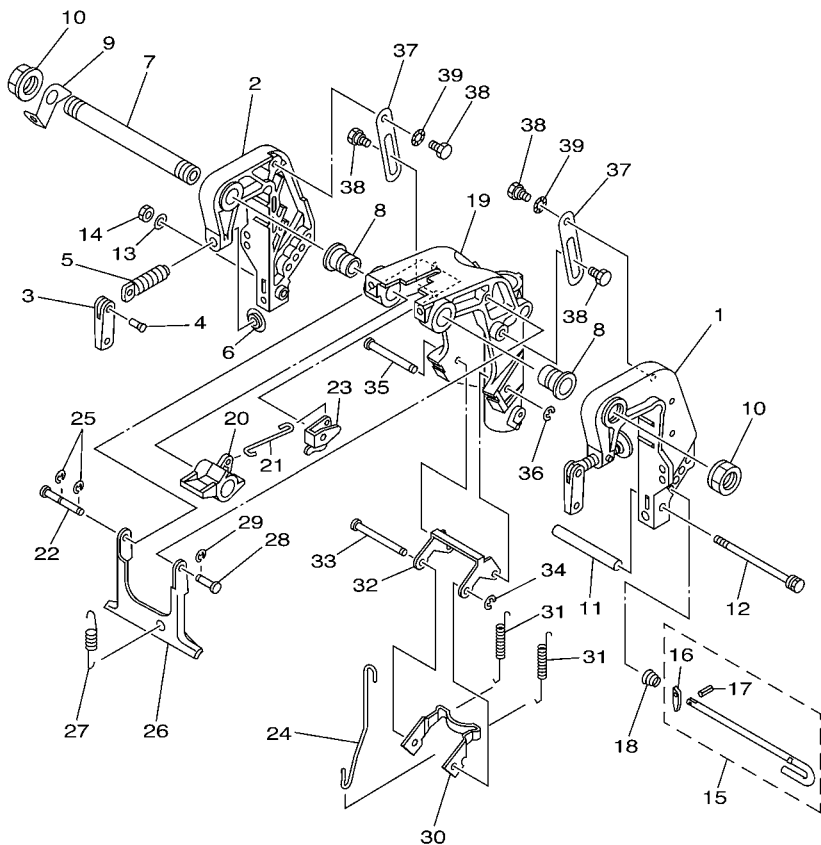

REF. NO.	PART NO. N° PIECES	DESCRIPTION DESCRIPTION	60N3	60R3	REMARKS REMARQUES
27	90506-18M41	SPRING, TENSION RESSORT, TENSION	1	1	S(17.1") S(17.1")
	90506-20005	SPRING, TENSION RESSORT, TENSION	1	1	L(22.1") L(22.1")
28	63V-43191-00	SHAFT, STOPPER AXE, BUTEE	1	1	
29	99080-05600	CIRCLIP CIRCLIP	1	1	
30	68T-43614-00	PLATE, TILT LOCK ETRIER, VERROUILLAGE MARCHE AR	1	1	
31	90506-20806	SPRING, TENSION RESSORT, TENSION	2	2	S(17.1") S(17.1")
	90506-23803	SPRING, TENSION RESSORT, TENSION	2	2	L(22.1") L(22.1")
32	68T-43615-00	PLATE, TILT LOCK ETRIER, VERROUILLAGE MARCHE AR	1	1	
33	68T-43611-00	SHAFT, TILT LOCK AXE, VERROUILLAGE MARCHE AR	1	1	
34	93430-04M03	CIRCLIP CLIPS	1	1	
35	68T-43659-00	SHAFT, REVERSE LOCK AXE, VERROUILLAGE MARCHE AR	1	1	
36	99080-05600	CIRCLIP CIRCLIP	1	1	
37	68T-43627-00	STOPPER PLAQUETTE	2	2	
38	90109-06M84	BOLT BOULON	4	4	
39	90206-10M24	WASHER, WAVE RONDELLE, ONDULEE	2	2	



68R3110-C200

FIG. 19 BRACKET 2

SUPPORT 2

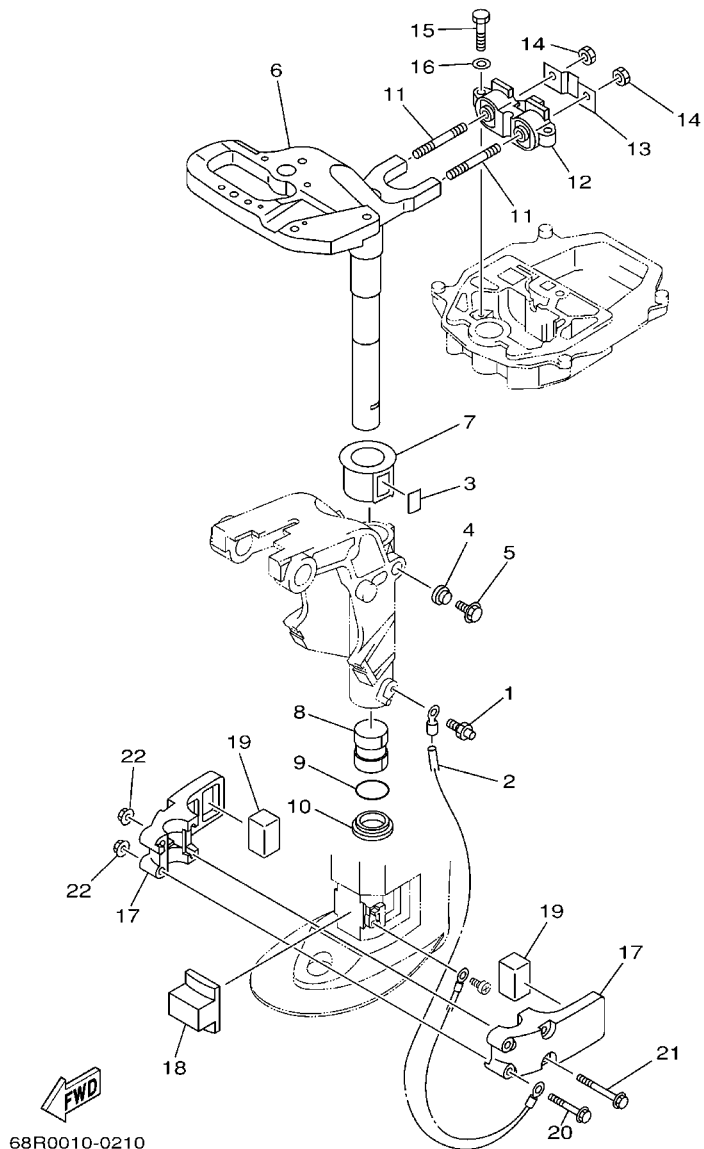

REF. NO.	PART NO. N° PIECES	DESCRIPTION DESCRIPTION	60N3	60R3	REMARKS REMARQUES
1	93700-06M03	NIPPLE, GREASE PION	1	1	
2	68T-82127-00	WIRE, LEAD 2 FIL 2	1	1	
3	63V-42528-00	PLATE, FRICTION PLAQUE, FRICTION	1	1	
4	689-43373-01	SEAL, DAMPER JOINT	1	1	
5	90105-06M07	BOLT, FLANGE BOULON	1	1	
6	60R-G2511-00-4D	BRACKET, STEERING CADRE, DIRECTION	1	1	S(17.1") S(17.1")
	60R-G2511-10-4D	BRACKET, STEERING CADRE, DIRECTION	1	1	L(22.1") L(22.1")
7	63V-42537-00	BUSHING, PIVOT SHAFT COUSSINET	1	1	
8	90386-30048	BUSH DOUILLE	1	1	
9	93210-29M94	O-RING JOINT TORIQUE	1	1	
10	90386-30M60	BUSH DOUILLE	1	1	
11	90116-08M54	BOLT, STUD GOUJON	2	2	
12	68T-44517-00-94	MOUNT RUBBER SILENT-BLOC	1	1	
13	68T-44526-00	PLATE PLAQUE	1	1	
14	95380-08600	NUT ECROU	2	2	
15	97075-06025	BOLT BOULON	2	2	
16	92995-06600	WASHER RONDELLE	2	2	
17	68T-44551-00-4D	HOUSING, LOWER MOUNT RUBBER BOITIER, SILENT-BLOC INFERIEUR	2	2	
18	60R-G4557-00	MOUNT DAMPER, LOWER FRONT SILENT-BLOC, INFERIEUR AVANT	1	1	
19	60R-G4555-00	MOUNT DAMPER, LOWER SIDE SILENT-BLOC, INFERIEUR LATERAL	2	2	
20	90119-06012	BOLT, WITH WASHER BOULON, AVEC RONDELLE	2	2	
21	90119-06013	BOLT, WITH WASHER BOULON, AVEC RONDELLE	2	2	
22	90179-06M28	NUT ECROU	4	4	

FIG. 20 UPPER CASING

FOURREAU

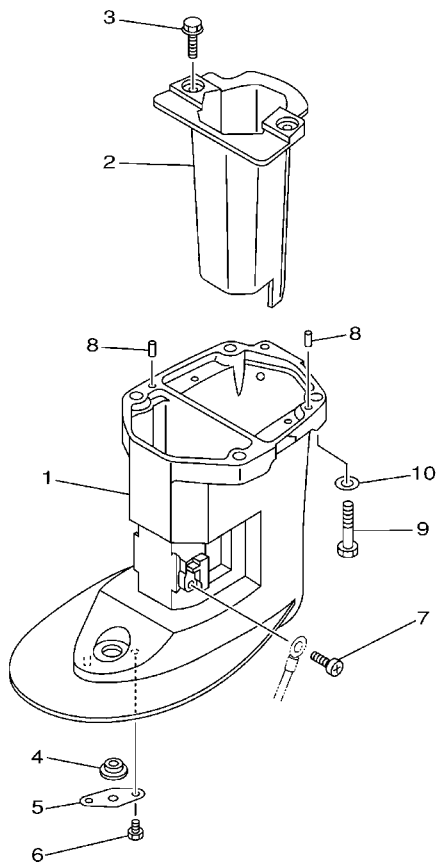

68R0010-0220

REF. NO.	PART NO. N° PIECES	DESCRIPTION DESCRIPTION	60N3	60F3			REMARKS REMARQUES
1	60R-G5111-00-4D	CASING, UPPER FOURREAU	1	1			S(17.1") S(17.1")
	60R-G5111-10-4D	CASING, UPPER FOURREAU	1	1			L(22.1") L(22.1")
2	60R-E4711-00-5B	MUFFLER 1 POT D'ECHAPPEMENT 1	1	1			
3	97575-06514	BOLT, WITH WASHER VIS HEXAGONAL AVC RONDELLE	2	2			
4	90480-14M54	GROMMET PASSE-FIL	1	1			
5	68T-45321-00	PLATE PLAQUETTE	1	1			
6	97095-06008	BOLT BOULON	1	1			
7	97885-05008	SCREW, PAN HEAD VIS, A ENCOCHE	1	1			
8	93604-12M07	PIN, DOWEL CLAVETTE	2	2			
9	97075-08035	BOLT BOULON	4	4			
10	92995-08600	WASHER RONDELLE	4	4			

FIG. 21 OIL PAN

VENTILATEUR D'HUILE

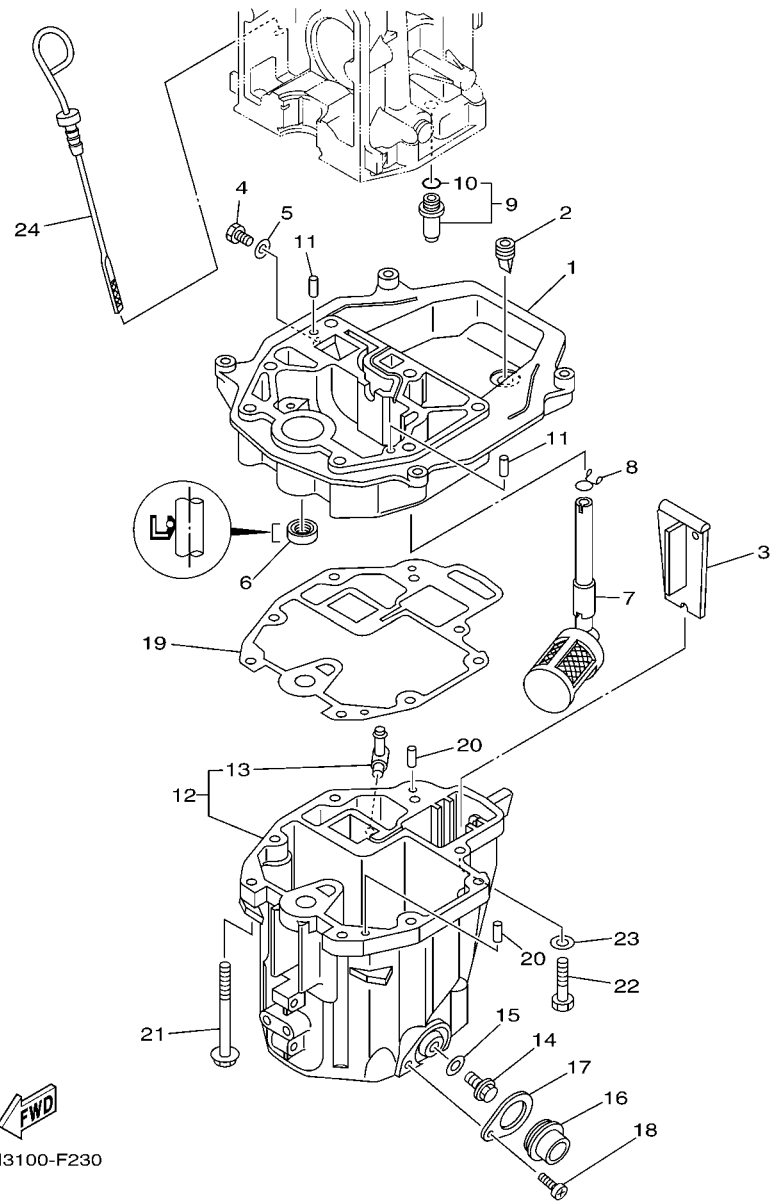

60N3100-F230

REF. NO.	PART NO. N° PIECES	DESCRIPTION DESCRIPTION	60N3	60R3	REMARKS REMARQUES
1	60R-G1137-00-94	GUIDE, EXHAUST COLLECTEUR D'ECHAPPEMENT	1	1	
2	60S-G2717-00	RUBBER, SEAL 2 JOINT EN CAOUTCHOUC 2	1	1	
3	60R-G5181-00	PLATE PLAQUETTE	1	1	
4	97095-08014	BOLT BOULON	1	1	
5	90430-08800	GASKET JOINT	1	1	
6	93101-12M70	OIL SEAL JOINT SPY	1	1	
7	68T-13421-01	STRAINER 2 FILTRE 2	1	1	
8	90467-11M08	CLIP JONC	1	1	
9	6G8-11575-00	RELIEF VALVE ASSY SOUPEA DE RENTREE D'AIR	1	1	
10	93210-12M62	.O-RING .JOINT TORIQUE	1	1	
11	93606-19M23	PIN, DOWEL GOUPILLE	2	2	
12	60R-E5311-00-5B	OIL PAN VENTILATEUR D'HUILE	1	1	
13	6H1-11372-00	.NIPPLE, HOSE .RACCORD, TUYAU	1	1	
14	90340-10M10	PLUG, STRAIGHT SCREW PLOT, FILETE DROIT	1	1	
15	90430-10M11	GASKET JOINT	1	1	
16	60R-E5316-00	DAMPER, ENGINE MOUNT 1 AMORTISSEUR DE SUPPORT	1	1	
17	68T-15317-00	SPACER, ENGINE MOUNT ENTRETOISE DE SUPPORT	1	1	
18	97885-05008	SCREW, PAN HEAD VIS, A ENCOCHE	1	1	
19	68T-13475-00	GASKET JOINT	1	1	
20	93604-12M07	PIN, DOWEL CLAVETTE	2	2	
21	90119-08005	BOLT, WITH WASHER BOULON, AVEC RONDELLE	6	6	
22	97075-08030	BOLT BOULON	2	2	
23	92995-08600	WASHER RONDELLE	2	2	
24	68T-15362-00	PLUG, OIL LEVEL PLOT, NIVEAU D'HUILE	1	1	

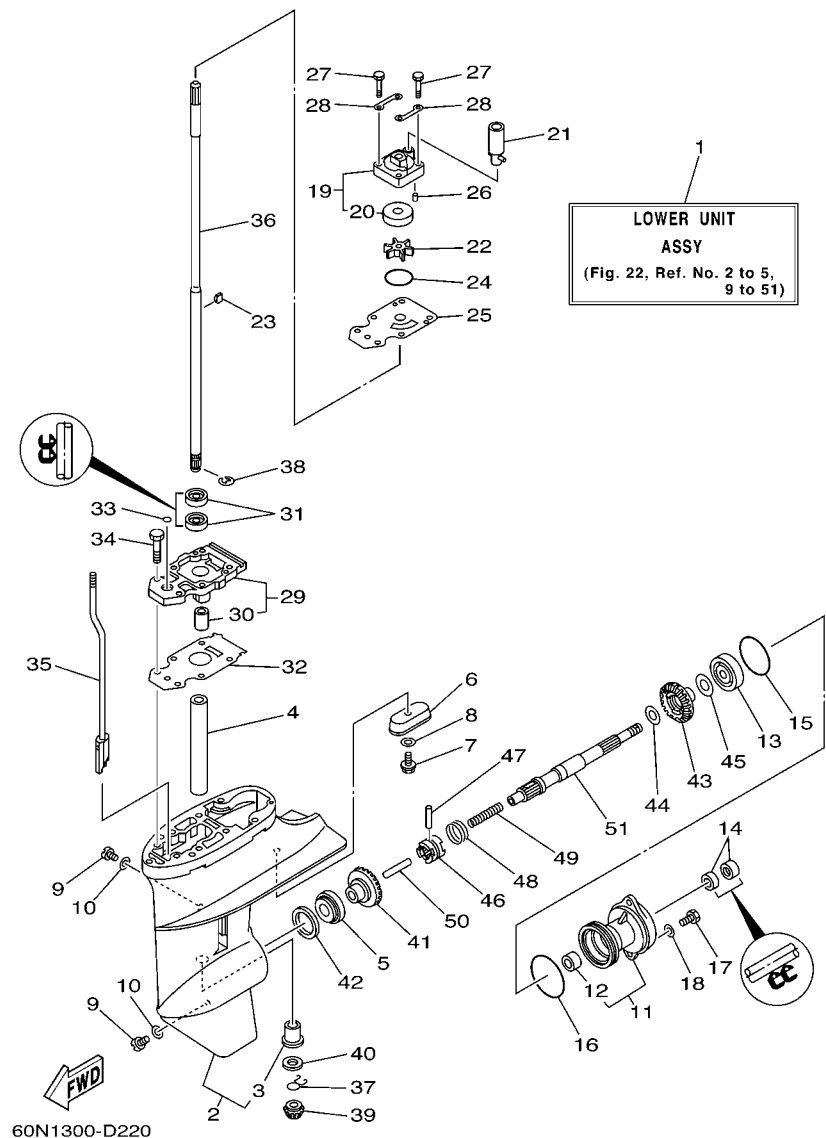

60N1300-D220

FIG. 22 LOWER CASING & DRIVE 1 BOITIER D'HELICE TRANSMISSION1

REF. NO.	PART NO. N° PIECES	DESCRIPTION DESCRIPTION	60N3	60R3		REMARKS REMARQUES
1	60R-G5300-00-4D	LOWER UNIT ASSY UNITE INFÉRIEURE (ENS.)	1	1		S(17.1") S(17.1")
	60R-G5300-10-4D	LOWER UNIT ASSY UNITE INFÉRIEURE (ENS.)	1	1		L(22.1") L(22.1")
2	60R-G5311-00-4D	CASING, LOWER BOITIER D'HELICE	1	1		
3	6G1-45317-09	.BUSHING, DRIVE SHAFT .DOUILLE, ARBRE MOTEUR	1	1		
4	90387-14M49	COLLAR COLLERETTE	1	1		
5	93306-004YH	BEARING ROULEMENT	1	1		
6	68T-45251-00	ANODE ANODE	1	1		
7	95895-06016	BOLT, FLANGE BOULON	1	1		
8	92990-06300	WASHER, INTERNAL TOOTH RONDELLE, DENTURE INTERNE	1	1		
9	90340-08002	PLUG, STRAIGHT SCREW PLOT, FILETE DROIT	2	2		
10	90430-08020	GASKET JOINT	2	2		
11	6N0-G5361-00-4D	CAP, LOWER CASING COUVERCLE, BOITIER D'HELICE	1	1		
12	6G1-45362-09	.BUSHING .COUSSINET	1	1		
13	93306-004YH	BEARING ROULEMENT	1	1		
14	93101-15074	OIL SEAL JOINT SPY	2	2		
15	93210-49046	O-RING JOINT TORIQUE	1	1		
16	93210-53M08	O-RING JOINT TORIQUE	1	1		
17	97095-06016	BOLT BOULON	2	2		
18	92995-06600	WASHER RONDELLE	2	2		
19	63V-44301-00	WATER PUMP HOUSING COMP. CARTER, POMPE A EAU (ENS.)	1	1		
20	63V-44322-00	.INSERT, CARTRIDGE .CUVETTE	1	1		
21	68T-44366-00	DAMPER, WATER SEAL JOINT, TUBE D'EAU	1	1		
22	68T-44352-00	IMPELLER TURBINE	1	1		
23	664-44338-00	KEY, WOODRUFF CLAVETTE, VOLANT	1	1		
24	93210-44398	O-RING JOINT TORIQUE	1	1		
25	68T-44323-00	OUTER PLATE, CARTRIDGE PLAQUE EXTERIEURE	1	1		
26	93604-12M07	PIN, DOWEL CLAVETTE	2	2		

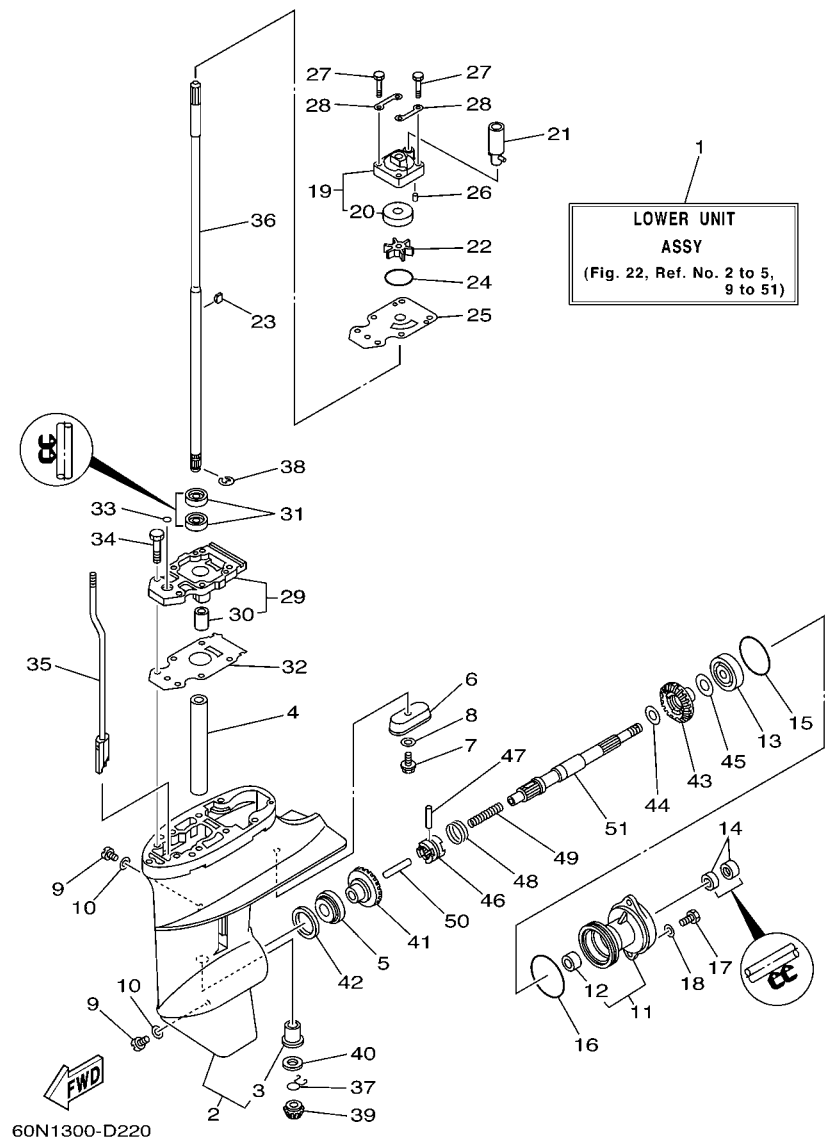
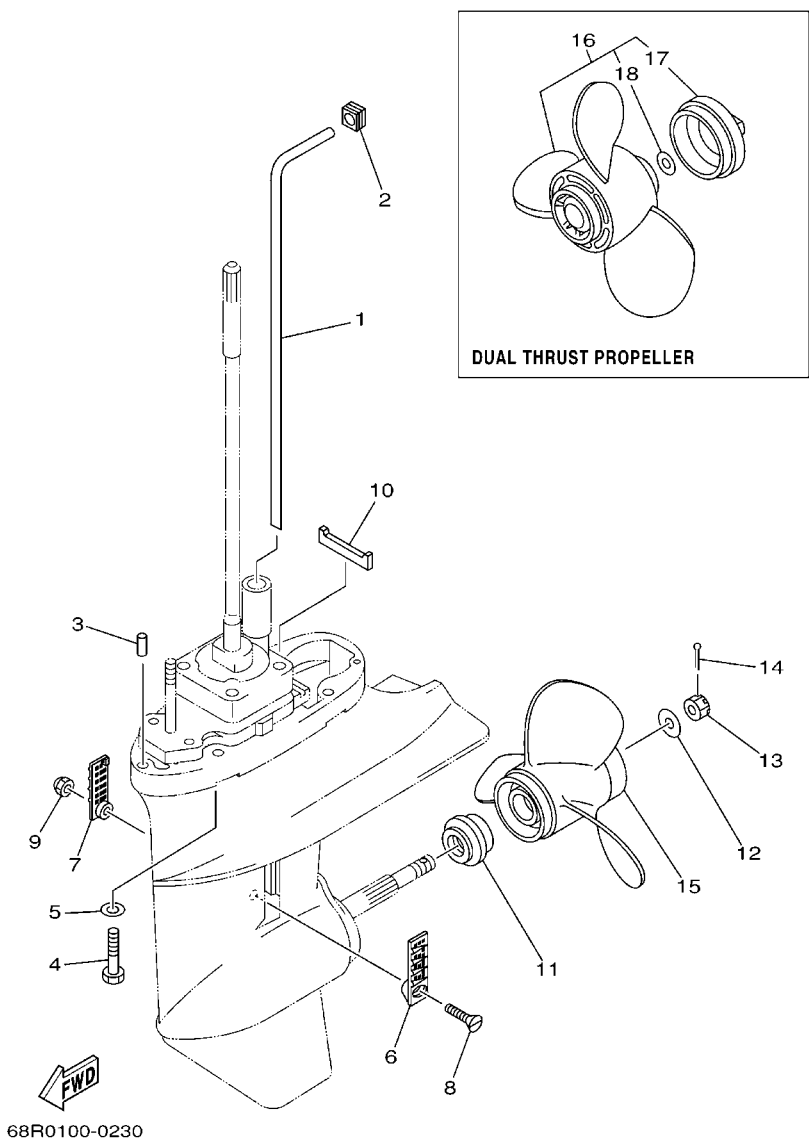

FIG. 22 LOWER CASING & DRIVE 1 BOITIER D'HELICE TRANSMISSION1

REF. NO.	PART NO. N° PIECES	DESCRIPTION DESCRIPTION	60N3	60R3	REMARKS REMARQUES
27	97080-08045	BOLT BOULON	4	4	
28	63V-44328-00	PLATE PLAQUETTE	2	2	
29	60R-G5331-00-5B	HOUSING, BEARING FLASQUE, ROULEMENT	1	1	
30	6G1-45316-09	.BUSHING, DRIVE SHAFT .DOUILLE, ARBRE MOTEUR	1	1	
31	93101-11M23	OIL SEAL JOINT SPY	2	2	
32	68T-45315-A0	PACKING, LOWER CASING JOINT, BOITIER D'HELICE	1	1	
33	93210-06ME6	O-RING JOINT TORIQUE	1	1	
34	97080-08025	BOLT BOULON	2	2	
35	60R-G4150-00	SHIFT CAM ASSY CAME D'INVERSION	1	1	
36	68T-45511-00	SHAFT, DRIVE ARBRE, MOTEUR	1	1	S(17.1") S(17.1")
	68T-45511-10	SHAFT, DRIVE ARBRE, MOTEUR	1	1	L(22.1") L(22.1")
37	90467-09M05	CLIP JONC	1	1	
38	99001-07600	CIRCLIP CIRCLIP	1	1	
39	6N0-G5551-A0	PINION (13T) PIGNON D'ATTAQUE (13D)	1	1	
40	6G1-45533-00	SHIM (T:1.90MM) CALE (T:1.90MM)	1	1	UR UR
	6G1-45533-10	SHIM (T:2.00MM) CALE (T:2.00MM)	1	1	UR UR
	6G1-45533-20	SHIM (T:2.10MM) CALE (T:2.10MM)	1	1	UR UR
	6G1-45533-30	SHIM (T:2.20MM) CALE (T:2.20MM)	1	1	UR UR
41	60R-G5560-00	GEAR 1 (27T) PIGNON 1 (27T)	1	1	
42	664-45587-01	SHIM (T:0.10MM) CALE (T:0.10MM)	1	1	UR UR
	664-45587-10	SHIM (T:0.12MM) CALE (T:0.12MM)	1	1	UR UR
	664-45587-20	SHIM (T:0.15MM) CALE (T:0.15MM)	1	1	UR UR
	664-45587-30	SHIM (T:0.18MM) CALE (T:0.18MM)	1	1	UR UR
	664-45587-40	SHIM (T:0.30MM) CALE (T:0.30MM)	1	1	UR UR
	664-45587-50	SHIM (T:0.40MM) CALE (T:0.40MM)	1	1	UR UR
	664-45587-60	SHIM (T:0.50MM) CALE (T:0.50MM)	1	1	UR UR
43	60R-G5571-00	GEAR 2 (27T) PIGNON 2 (27T)	1	1	

FIG. 23 LOWER CASING & DRIVE 2

BOITIER D'HELICE TRANSMISSION2



REF. NO.	PART NO. N° PIECES	DESCRIPTION DESCRIPTION	60N3	60R3	REMARKS REMARQUES
1	68T-44361-00	TUBE, WATER TUBE D'EAU	1	1	S(17.1") S(17.1")
	68T-44361-10	TUBE, WATER TUBE D'EAU	1	1	L(22.1") L(22.1")
2	63V-44365-10	DAMPER, WATER SEAL JOINT, TUBE D'EAU	1	1	
3	93604-12M07	PIN, DOWEL CLAVETTE	2	2	
4	97075-08035	BOLT BOULON	4	4	
5	92995-08600	WASHER RONDELLE	4	4	
6	6G1-45214-00	COVER, WATER INLET 1 GRILLE, ENTREE D'EAU 1	1	1	
7	6G1-45215-00	COVER, WATER INLET 2 GRILLE, ENTREE D'EAU 2	1	1	
8	90152-05M03	SCREW, COUNTERSUNK VIS, TETE NOYEE	1	1	
9	90185-05002	NUT, SELF-LOCKING ECROU, AUTO-BLOQUANT	1	1	
10	63V-45375-00	DAMPER, SEAL BOURRELET, CAOUTCHOUC	1	1	
11	6N0-G5987-10	SPACER ENTRETOISE	1	1	
12	90201-10M01	WASHER, PLATE RONDELLE, PLATE	1	1	
13	90171-10M01	NUT, CASTLE ECROU, CRENELE	1	1	
14	91490-30020	PIN, COTTER GOUPILLE	1	1	
15	6G1-45941-00-EL	PROPELLER (3X8-1/2"X8-1/2"-N) HELICE (3X8-1/2"X8-1/2"-N)	1	1	UR
	6G1-45943-00-EL	PROPELLER (3X8-1/2"X7-1/2"-N) HELICE (3X8-1/2"X7-1/2"-N)	1	1	UR
	6G1-45947-00-EL	PROPELLER (3X8-1/2"X6-1/2"-N) HELICE (3X8-1/2"X6-1/2"-N)	1	1	UR
	6G1-45952-00-EL	PROPELLER (3X8-1/2"X8"-N) HELICE (3X8-1/2"X8"-N)	1	1	UR
16	6G1-W4591-01-EL	PROPELLER (3X9"X7"-N) HELICE (3X9"X7"-N)	1	1	UR
	6G1-W4592-00-EL	PROPELLER (3X9"X5"-N) HELICE (3X9"X5"-N)	1	1	UR
17	6G1-45616-01	.NUT, PROPELLER .CONE, HELICE	1	1	
18	90201-10M02	.WASHER, PLATE .RONDELLE, PLATE	1	1	

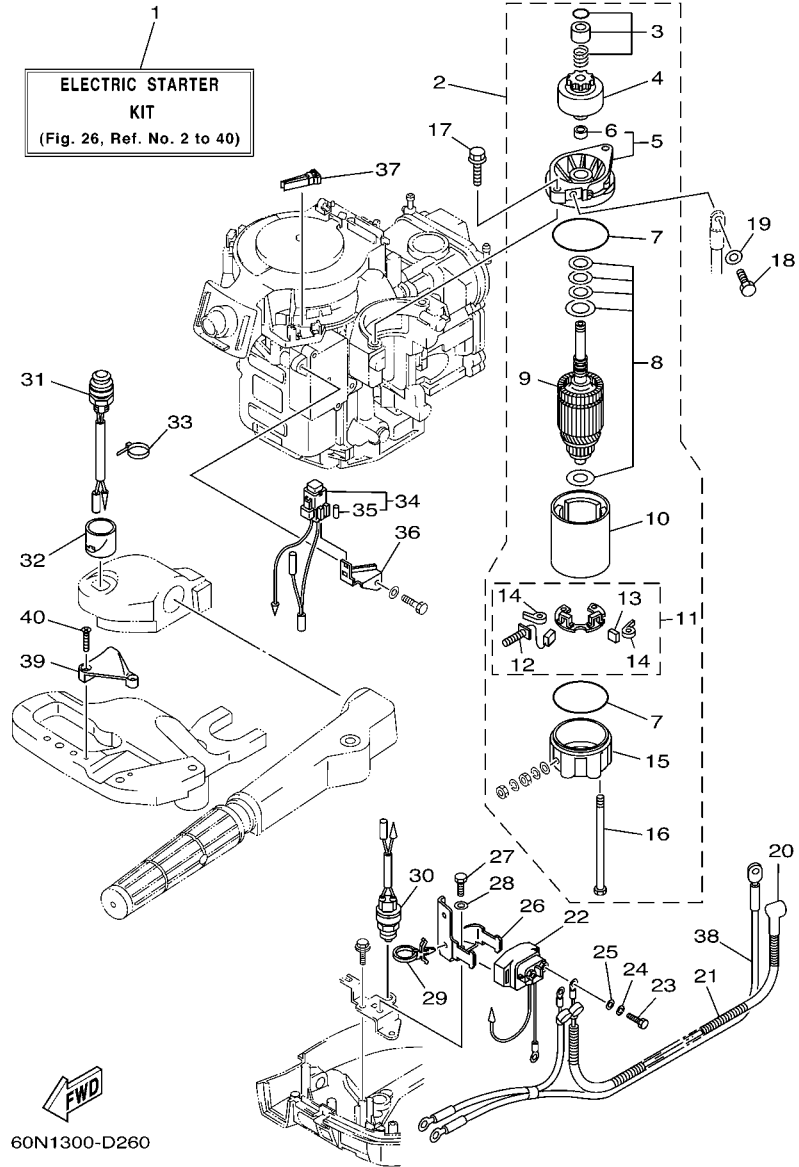
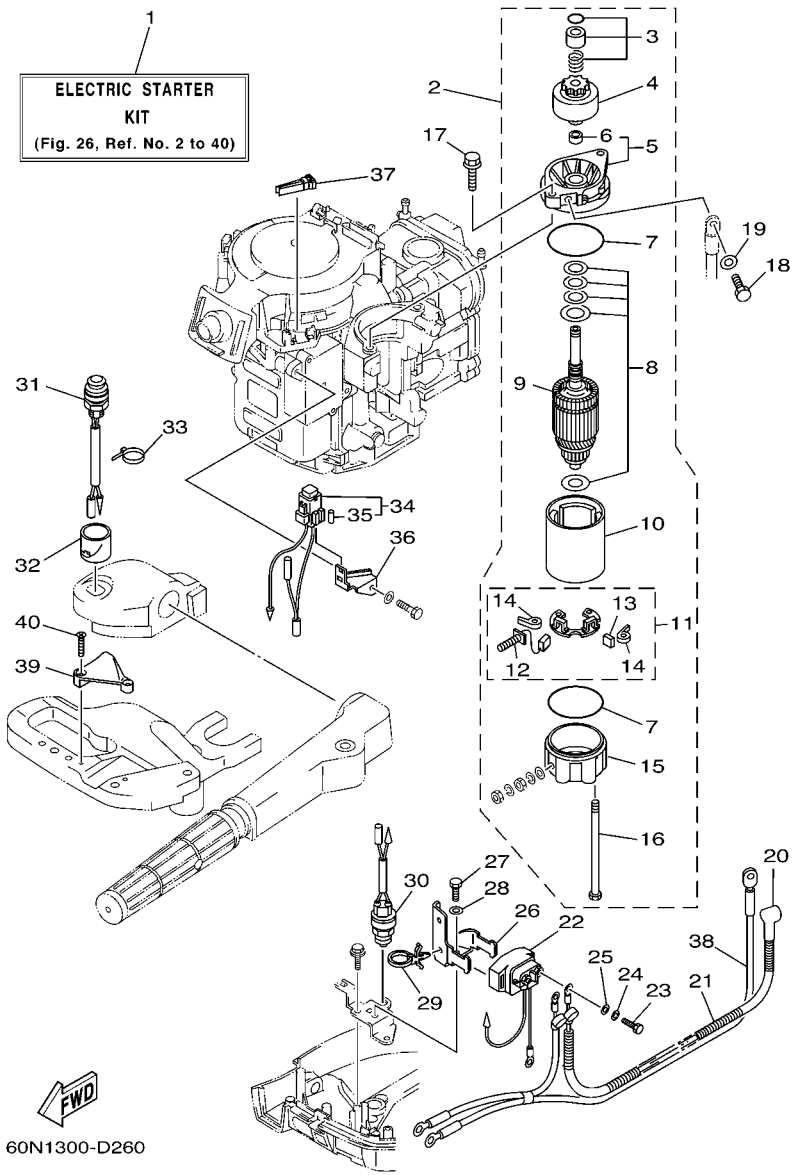

FIG. 26 OPTIONAL PARTS 1

PIECES OPTIONNELLES 1

REF. NO.	PART NO. N° PIECES	DESCRIPTION DESCRIPTION	60N3	60R3		REMARKS REMARQUES
1	68R-W8180-00	ELECTRIC STARTER KIT KIT DEMARREUR ELECTRIQUE	1	1		AP AP
2	68T-81800-00	STARTING MOTOR ASSY DEMARREUR ELECTRIQUE COMPLET	1	1		
3	68T-81857-00	.RETAINER .ARRETOIR	1	1		
4	689-81807-12	.GEAR ASSY, STARTING MOTOR .PIGNON, DEMARREUR ELECTRIQUE	1	1		
5	6F5-81830-10	.FRONT BRACKET ASSY .SUPPORT AVANT	1	1		
6	689-81831-00	..METAL, FRONT ..METAL, AVANT	1	1		
7	689-81847-11	.O-RING .JOINT TORIQUE	2	2		
8	689-81809-11	.WASHER KIT .JEU DE RONDELLES	1	1		
9	689-81850-11	.ARMATURE ASSY .INDUIT	1	1		
10	689-81810-11	.STATOR ASSY .STATOR COMPLET	1	1		
11	689-81840-11	.BRUSH HOLDER ASSY .SUPPORT DE CHARBON	1	1		
12	689-81811-11	..BRUSH 1 ..CHARBON 1	1	1		
13	689-81812-11	..BRUSH 2 ..CHARBON 2	1	1		
14	689-81813-10	..SPRING, BRUSH ..RESSORT, DE CHARBON	2	2		
15	689-81820-11	.REAR BRACKET ASSY .SUPPORT ARRIERE COMPLET	1	1		
16	689-81826-10	.BOLT .BOULON	2	2		
17	90119-08M76	BOLT, WITH WASHER BOULON, AVEC RONDELLE	2	2		
18	97095-08016	BOLT BOULON	1	1		
19	92995-08600	WASHER RONDELLE	1	1		
20	6G8-82117-00	WIRE, LEAD FIL	1	1		
21	90446-10M86	HOSE (L140) DURITE (L140)	1	1		
22	68T-81940-00	STARTER RELAY ASSY LANCEUR RELAIS (ENS.)	1	1		
23	97095-06010	BOLT BOULON	2	2		
24	92995-06100	WASHER, SPRING RONDELLE, GROWER	2	2		
25	92995-06600	WASHER RONDELLE	2	2		
26	68T-81945-00	PLATE, SWITCH FITTING PLAQUE, FIXATION DU RELAIS	1	1		
27	97095-06012	BOLT BOULON	1	1		



60N1300-D260

FIG. 26 OPTIONAL PARTS 1

PIECES OPTIONNELLES 1

REF. NO.	PART NO. N° PIECES	DESCRIPTION DESCRIPTION	60N3	60F3	REMARKS REMARQUES
28	92995-06600	WASHER RONDELLE	1	1	
29	90465-12M56	CLAMP BRIDE	1	1	
30	6F5-82540-00	NEUTRAL SWITCH ASSY CONTACTEUR DE POINT-MORT	1	1	
31	68T-81870-00	STARTING SWITCH ASSY CONTACT A CLEF	1	1	
32	68T-81821-00	COVER, SWITCH COUVERCLE, COMMUTATEUR	1	1	
33	90465-11M10	CLAMP BRIDE	1	1	
34	68T-82150-00	FUSE HOLDER ASSY SUPPORT DE FUSIBLE	1	1	
35	66V-82151-00	.FUSE (10A-BL) .FUSIBLE (10A-BL)	2	2	
36	68T-82171-00	STAY, FUSE BOX SUPPORT, BOITE A FUSIBLES	1	1	
37	67F-2812A-00	PULLER, FUSE TENDEUR, FUSIBLE	1	1	
38	68T-82105-00	WIRE HARNESS (L: 2.1M) FAISCEAU DE FILS (L: 2.1M)	1	1	
39	68T-82594-00	CLAMP BRIDE	1	1	
40	90151-05003	SCREW, COUNTERSUNK VIS, TETE NOYEE	2	2	

FIG. 28 REPAIR KIT 1

KITS DE REPARATION 1

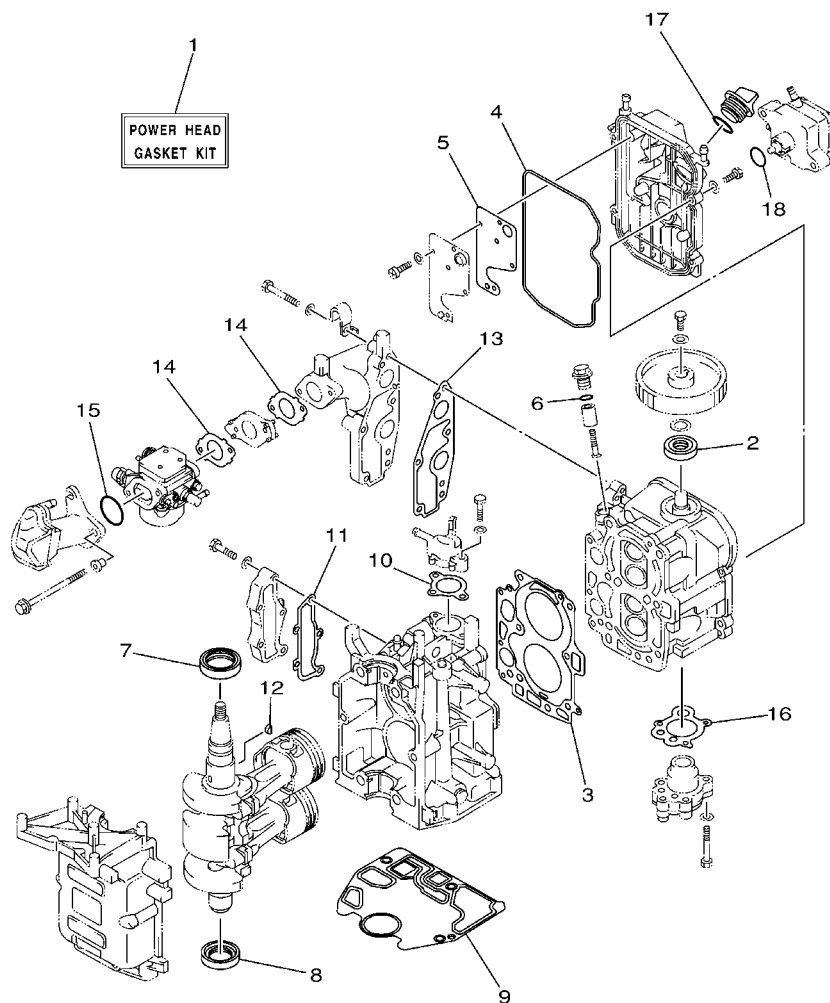

68R0100-0250

REF. NO.	PART NO. N° PIECES	DESCRIPTION DESCRIPTION	60N3	60R3	REMARKS REMARQUES
1	68T-W0001-00	POWER HEAD GASKET KIT POCHETTE DE JINTS TETE MOTRICE	1	1	
2	93102-18M21	.OIL SEAL .JOINT SPY	1	1	
3	68T-11181-00	.GASKET, CYLINDER HEAD 1 .JOINT, DE CULASSE 1	1	1	
4	68T-11356-00	.SEAL, CYLINDER 2 .JOINT, SPY CYLINDRE	1	1	
5	68T-11169-A0	.GASKET, BREATHER COVER .JOINT, COUVERCLE DE RENIFLARD	1	1	
6	93210-13M63	.O-RING .JOINT TORIQUE	1	1	
7	93102-30M22	.OIL SEAL .JOINT SPY	1	1	
8	93101-25M69	.OIL SEAL .JOINT SPY	1	1	
9	68T-11351-00	.GASKET, CYLINDER .JOINT, D'EMBASE	1	1	
10	60R-E2414-A0	.GASKET, COVER .JOINT, COUVERCLE	1	1	
11	68T-41114-A0	.GASKET, EXHAUST OUTER COVER .JOINT, COUVERCLE D'ECHAPPEMEN	1	1	
12	90280-03M01	.KEY, WOODRUFF .CLAVETTE, DEMI-LUNE	1	1	
13	68T-13645-00	.GASKET, MANIFOLD 1 .JOINT, TUBULURE 1	1	1	
14	60R-E3646-A0	.GASKET, MANIFOLD 2 .JOINT, TUBULURE 2	2	2	
15	93210-31MJ5	.O-RING .JOINT TORIQUE	1	1	
16	68T-13329-00	.GASKET, PUMP COVER .JOINT, COUVERCLE DE POMPE	1	1	
17	93210-24M79	.O-RING .JOINT TORIQUE	1	1	
18	93210-20M65	.O-RING .JOINT TORIQUE	1	1	

FIG. 30 REPAIR KIT 3

KITS DE PEPARATION 3

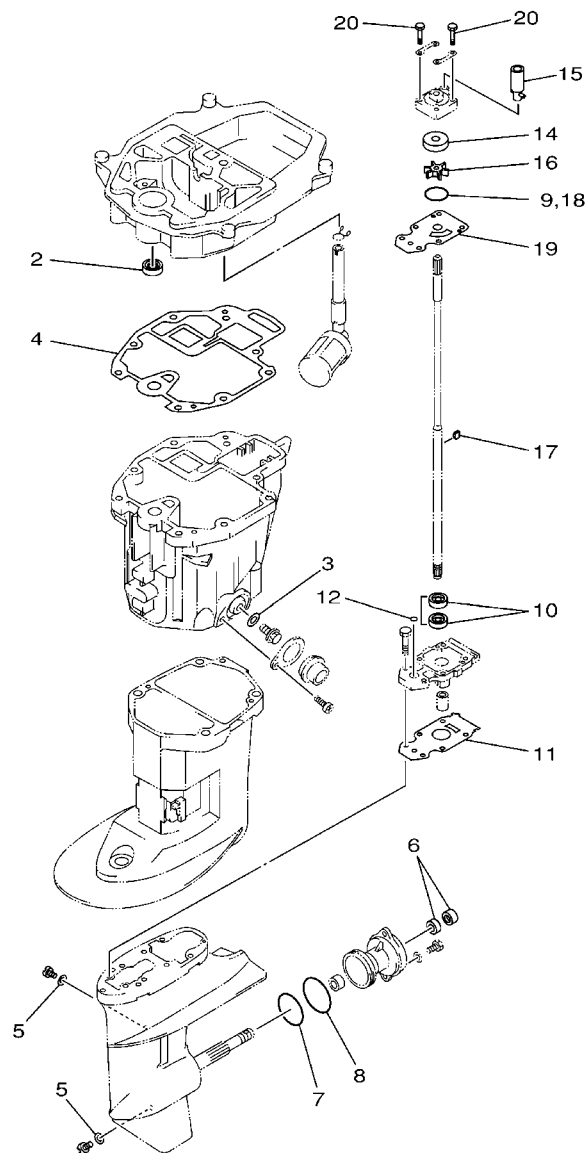

68R0100-0270

REF. NO.	PART NO. N° PIECES	DESCRIPTION DESCRIPTION	60N3	60R3	REMARKS REMARQUES
1	68T-W0001-20	LOWER UNIT GASKET KIT POCHETTE DE JOINTS EMBASE	1	1	
2	93101-12M70	.OIL SEAL .JOINT SPY	1	1	
3	90430-10M11	.GASKET .JOINT	1	1	
4	68T-13475-00	.GASKET .JOINT	1	1	
5	90430-08020	.GASKET .JOINT	2	2	
6	93101-15074	.OIL SEAL .JOINT SPY	2	2	
7	93210-49046	.O-RING .JOINT TORIQUE	1	1	
8	93210-53M08	.O-RING .JOINT TORIQUE	1	1	
9	93210-44398	.O-RING .JOINT TORIQUE	1	1	
10	93101-11M23	.OIL SEAL .JOINT SPY	2	2	
11	68T-45315-A0	.PACKING, LOWER CASING .JOINT, BOITIER D'HELICE	1	1	
12	93210-06ME6	.O-RING .JOINT TORIQUE	1	1	
13	68T-W0078-00	WATER PUMP REPAIR KIT KIT DE REPARATION DE LA POMPE	1	1	
14	63V-44322-00	.INSERT, CARTRIDGE .CUVETTE	1	1	
15	68T-44366-00	.DAMPER, WATER SEAL .JOINT, TUBE D'EAU	1	1	
16	68T-44352-00	.IMPELLER .TURBINE	1	1	
17	664-44338-00	.KEY, WOODRUFF .CLAVETTE, VOLANT	1	1	
18	93210-44398	.O-RING .JOINT TORIQUE	1	1	
19	68T-44323-00	.OUTER PLATE, CARTRIDGE .PLAQUE EXTERIEURE	1	1	
20	97080-08045	.BOLT .BOULON	4	4	

NUMERICAL INDEX
INDEX NUMERIQUE

PART NO. N° PIECES	REF. NO.	PART NO. N° PIECES	REF. NO.	PART NO. N° PIECES	REF. NO.	PART NO. N° PIECES	REF. NO.	PART NO. N° PIECES	REF. NO.	PART NO. N° PIECES	REF. NO.
67D-11133-10	4 - 3	68T-13645-00	28 - 13	63V-15767-01	10 - 10	6G1-42126-00	15 - 5	68T-44323-00	30 - 19	6G1-45952-00-EL	23 - 15
68T-11168-00	4 - 14	68T-14126-00	7 - 19	68T-15770-00	10 - 21	68T-42131-01	15 - 21	63V-44328-00	22 - 28	663-48344-00	17 - 12
68T-11169-A0	4 - 15	68T-14271-00	6 - 9	68T-15774-10	10 - 26	6G1-42138-01	15 - 2	664-44338-00	22 - 23	63V-48511-01	17 - 17
	28 - 5	60N-14301-20	7 - 1	6G1-15779-00	10 - 17	63V-42528-00	19 - 3		30 - 17	68T-48531-00	17 - 2
68T-11181-00	4 - 4	68T-14301-20	7 - 1	68T-15784-00	10 - 11	63V-42537-00	19 - 7	68T-44352-00	22 - 22	682-48538-50	17 - 3
	28 - 3	6E5-14321-00	7 - 2	6A0-15789-00	10 - 18	60R-42615-00	1 - 6		30 - 16	68T-61350-00	25 - 1
6G8-11197-01	4 - 20	68T-14323-20	7 - 16	68T-15793-00	10 - 13	68T-42649-00	1 - 10	68T-44361-00	23 - 1	68T-61351-00	25 - 2
6G8-11325-00	4 - 18	6E7-14325-00	9 - 15	68T-15794-00	10 - 19	6G1-42651-02	1 - 4	68T-44361-10	23 - 1	6E5-61355-00	25 - 7
68T-11351-00	2 - 5	6J8-14334-00	7 - 3	68T-15795-00	10 - 4	60R-42652-00	1 - 7	63V-44365-10	23 - 2	68T-81800-00	26 - 2
	28 - 9	68T-14385-00	7 - 5	6YL-24201-04	24 - 1	68R-42677-00	1 - 13	68T-44366-00	22 - 21	689-81807-12	26 - 4
68T-11356-00	4 - 11		29 - 2	68T-24251-00	9 - 7	68T-42677-00	1 - 13		30 - 15	689-81809-11	26 - 8
	28 - 4	67D-14386-00	7 - 7	6YL-24260-01	24 - 3	68R-42678-20	1 - 11	6H3-44391-01	14 - 9	689-81810-11	26 - 10
6H1-11372-00	21 - 13		29 - 3	6YL-24268-01	24 - 6	68T-42678-20	1 - 11	68T-44517-00-94	19 - 12	689-81811-11	26 - 12
68T-11416-00	3 - 4	647-14395-60	16 - 28	6G1-24304-02	9 - 1	68T-42716-10	14 - 5	68T-44526-00	19 - 13	689-81812-11	26 - 13
68T-11416-10	3 - 4	68T-14497-00	16 - 21	6YL-24306-54	24 - 7	68T-42717-00	14 - 25	68T-44551-00-4D	19 - 17	689-81813-10	26 - 14
68T-11416-20	3 - 4	67D-14527-00	7 - 18	6YL-24329-00	24 - 5	68T-42725-00	14 - 13	6G1-45214-00	23 - 6	689-81820-11	26 - 15
68T-11557-00	8 - 9	67D-14536-00	7 - 17	66M-24374-00	9 - 19	6G1-42725-00	13 - 4	6G1-45215-00	23 - 7	68T-81821-00	26 - 32
6G8-11575-00	21 - 9		29 - 8	650-24378-00	4 - 10	68T-42725-10	17 - 16	68T-45251-00	22 - 6	68T-81822-00-94	12 - 20
6G8-11587-01	8 - 10	68T-14546-00	7 - 8	6E9-24378-00	2 - 14	688-42726-10	14 - 18	68T-45315-A0	22 - 32	689-81826-10	26 - 16
68T-11650-00	3 - 5		29 - 4	68T-24410-01	9 - 12	682-42727-00	14 - 10		30 - 11	6F5-81830-10	26 - 5
67D-11654-00	3 - 6	68T-1492A-00	7 - 11	66M-24411-01	9 - 16	68T-42738-00-4D	14 - 11	6G1-45316-09	22 - 30	689-81831-00	26 - 6
67D-12111-00	5 - 1	68T-1492E-37	7 - 9	66M-24413-01	9 - 13	6H8-42791-10	14 - 38	6G1-45317-09	22 - 3	689-81840-11	26 - 11
68T-12116-00	5 - 3	60N-1492E-3D	7 - 9	6A0-24421-01	9 - 14	68T-42801-00	14 - 6	68T-45321-00	20 - 5	689-81847-11	26 - 7
7NJ-12117-00	5 - 5	68T-1492F-1K	7 - 10	66M-24423-00	9 - 17	66R-43113-00	18 - 9	6G1-45362-09	22 - 12	689-81850-11	26 - 9
7NJ-12118-00	5 - 6	60N-1492F-20	7 - 10	66M-24444-00	9 - 22	648-43114-01	18 - 6	63V-45375-00	23 - 10	68T-81857-00	26 - 3
51Y-12119-00	5 - 7	6J8-14959-00	7 - 14	66M-24454-00	9 - 20	6E7-43116-00	18 - 5	68T-45511-00	22 - 36	68T-81870-00	26 - 31
67D-12121-00	5 - 2		29 - 6	66M-24471-01	9 - 21	63V-43131-10	18 - 7	68T-45511-10	22 - 36	68T-81940-00	26 - 22
68T-12146-00	5 - 8	67D-14966-00	7 - 6	6YL-24610-01	24 - 2	6E5-43145-01	25 - 9	6G1-45533-00	22 - 40	68T-81945-00	26 - 26
68T-12151-00	5 - 12	68T-14981-00	7 - 13	68T-26301-01	15 - 16	6L2-43160-01	18 - 15	6G1-45533-10	22 - 40	68T-81949-00	27 - 1
6G8-12158-00	5 - 14	67D-14984-00	7 - 12	68T-26367-00	14 - 15	689-43165-00	18 - 16	6G1-45533-20	22 - 40	68T-81960-00	12 - 13
6G8-12159-00	5 - 13		29 - 5	68T-26393-00	14 - 14	63V-43191-00	18 - 28	6G1-45533-30	22 - 40	68T-82105-00	26 - 38
66M-12411-01	2 - 6	66T-14991-00	7 - 15	68T-28100-00	9 - 34	68T-43350-00	18 - 26	647-45567-00	22 - 45	6G8-82117-00	26 - 20
688-12412-00	2 - 7	68T-15317-00	21 - 17	67F-2812A-00	26 - 37	689-43373-01	19 - 4	664-45587-01	22 - 42	68T-82127-00	19 - 2
68T-12413-00-1S	2 - 8	68T-15362-00	21 - 24		27 - 4	68T-43611-00	18 - 33	664-45587-10	22 - 42	68T-82127-10	12 - 18
67F-12482-00	6 - 2	63V-15705-01	10 - 9	61H-2819R-31	9 - 33	68T-43614-00	18 - 30	664-45587-20	22 - 42	68T-82150-00	26 - 34
68T-12535-00	14 - 35	68T-15710-11	10 - 1	68T-41114-A0	2 - 15	68T-43615-00	18 - 32	664-45587-30	22 - 42	66V-82151-00	26 - 35
68T-12572-00	14 - 33	68T-15711-02	10 - 2		28 - 11	68T-43617-00	18 - 24	664-45587-40	22 - 42		27 - 2
6R3-12581-00	14 - 32	63V-15713-00	10 - 7	68T-41211-00	16 - 20	68T-43627-00	18 - 37	664-45587-50	22 - 42	68T-82171-00	26 - 36
6R3-12582-00	14 - 30	63V-15714-00	10 - 5	68T-41256-00	6 - 21	68T-43641-00	18 - 23	664-45587-60	22 - 42		27 - 3
6R3-12583-00	14 - 31	68T-15716-00	10 - 8	6J8-41262-00	6 - 22	68T-43646-00	18 - 22	68T-45611-00	22 - 51	6E3-82370-21	12 - 12
66M-13131-00	9 - 18	66T-15731-00	10 - 22	661-41262-02	16 - 27	68T-43659-00	18 - 35	6G1-45616-01	23 - 17	67F-82504-00	12 - 17
68T-13300-00	8 - 15	66T-15734-00	10 - 20	6H4-41271-01	6 - 19	66R-44114-00	16 - 11	68T-45631-00	22 - 46	68T-82522-00	12 - 2
68T-13329-00	8 - 16	63V-15741-00	10 - 6	689-41273-00	6 - 20	65W-44116-00	16 - 10	6G1-45632-00	22 - 47	6F5-82540-00	26 - 30
	28 - 16	63V-15744-00	10 - 12	68R-41283-00	16 - 18	68T-44121-01	16 - 5	654-45633-00	22 - 48	682-82556-00	13 - 2
68T-13421-01	21 - 7	6G1-15755-00	10 - 15	68T-41283-00	16 - 18	63V-44301-00	22 - 19	6G1-45635-00	22 - 50	65W-82575-01	13 - 1
68T-13475-00	21 - 19	68T-15762-00	10 - 25	68T-41638-00	16 - 17	63V-44322-00	22 - 20	6G1-45941-00-EL	23 - 15	689-8257Y-00	13 - 3
	30 - 4	67D-15764-00	10 - 3	6G1-41662-01-94	16 - 6		30 - 14	6G1-45943-00-EL	23 - 15	68T-82594-00	26 - 39
68T-13645-00	6 - 3	68T-15764-00	10 - 14	6G1-42125-01	15 - 6	68T-44323-00	22 - 25	6G1-45947-00-EL	23 - 15	68F-85119-00	14 - 2

NUMERICAL INDEX
INDEX NUMERIQUE

PART NO. N° PIECES	REF. NO.	PART NO. N° PIECES	REF. NO.	PART NO. N° PIECES	REF. NO.	PART NO. N° PIECES	REF. NO.	PART NO. N° PIECES	REF. NO.	PART NO. N° PIECES	REF. NO.
68T-85410-00	12 - 19	60R-F8199-72-G0	9 - 35	60R-G5331-00-5B	22 - 29	90119-08005	21 - 21	90386-34M97	15 - 17	90506-20005	18 - 27
68T-85520-00	11 - 2	60R-F8199-72-H0	9 - 35	6N0-G5361-00-4D	22 - 11	90119-08020	12 - 22	90387-06053	14 - 4	90506-20806	18 - 31
68T-85533-10	11 - 4	60R-F8199-72-S0	9 - 35	6N0-G5551-A0	22 - 39	90119-08046	12 - 21	90387-06M13	18 - 11	90506-23803	18 - 31
68R-85540-00	12 - 1	60R-F8199-82-K0	9 - 36	60R-G5560-00	22 - 41	90119-08M29	2 - 4	90387-06M59	16 - 19	91490-16010	15 - 7
68T-85540-00	12 - 1	60R-F8199-82-L0	9 - 36	60R-G5571-00	22 - 43	90119-08M76	26 - 17	90387-06M70	6 - 12	91490-30020	23 - 14
68T-85550-11	11 - 1	60R-F8199-82-M0	9 - 36	6N0-G5987-10	23 - 11	90149-05M13	15 - 12	90387-10M42	25 - 6	91690-30008	18 - 17
680-85570-01	12 - 8	60R-F8199-82-N0	9 - 36	60R-G6241-00	8 - 7	90151-05003	26 - 40	90387-13M56	5 - 9	91690-30012	17 - 4
68T-85580-01	11 - 3	60R-F8199-82-P0	9 - 36	60R-G6297-00	8 - 13	90152-05M03	23 - 8	90387-14M03	5 - 10	91690-30014	16 - 9
6H2-85582-00	11 - 5	60R-F8199-82-R0	9 - 36	60R-G8501-00	17 - 1	90157-05M16	24 - 4	90387-14M49	22 - 4	91690-50014	6 - 6
60R-E1111-00-1S	4 - 2	60R-G1113-00-1S	2 - 13	68D-H257H-00	14 - 40	90167-06002	14 - 34	90430-08020	22 - 10	91812-12001	2 - 3
60R-E1191-00-1S	4 - 9	60R-G1137-00-94	21 - 1	60R-H3625-40	10 - 28	90170-06015	16 - 15		30 - 5	92907-04600	4 - 17
60R-E1411-00	3 - 3	60R-G2111-00-4D	15 - 1	60R-H3625-50	10 - 29	90170-09M03	25 - 5	90430-08800	21 - 5	92990-06300	22 - 8
60R-E1536-00	8 - 8	68D-G2119-00	15 - 9	60R-H3627-40	15 - 27	90170-12066	11 - 11	90430-10M11	21 - 15	92990-06600	18 - 13
60R-E1537-00-94	8 - 3	60R-G2121-00-4D	15 - 24	60R-H3627-50	15 - 28	90170-24M09	8 - 11		30 - 3	92995-05600	1 - 9
60R-E1603-00	3 - 8	60N-G2137-00	15 - 10	60R-H4342-00	14 - 26	90171-10M01	23 - 13	90445-09812	6 - 7		16 - 4
60R-E1604-00	3 - 8	60R-G2137-00	15 - 10	60R-H5711-60	10 - 31	90179-06M28	19 - 22	90445-10809	9 - 5		17 - 11
60R-E1605-00	3 - 8	68D-G2159-00	15 - 3	68T-W0001-00	28 - 1	90179-10M33	15 - 26	90445-10810	9 - 28	92995-06100	9 - 25
60R-E1631-00-96	3 - 7	68D-G2177-10	15 - 8	68T-W0001-20	30 - 1	90185-05002	23 - 9	90445-10811	9 - 8		14 - 22
60R-E1633-00	3 - 9	60R-G2511-00-4D	19 - 6	68T-W0070-60	1 - 12	90185-08057	15 - 23	90446-10M86	26 - 21		26 - 24
60R-E1635-00	3 - 7	60R-G2511-10-4D	19 - 6	68T-W0078-00	30 - 13		17 - 20	90446-14M66	9 - 10	92995-06600	4 - 10
60R-E1636-00	3 - 7	60N-G2610-00-4D	1 - 1	68T-W0093-00	29 - 1	90185-09M01	25 - 4	90447-13M00	14 - 29		6 - 18
60R-E2113-00	5 - 4	60R-G2610-00-4D	1 - 1	6G1-W4591-01-EL	23 - 16	90185-22043	18 - 10	90464-10M53	9 - 32		8 - 18
60R-E2138-60	8 - 19	60R-G2613-00	1 - 2	6G1-W4592-00-EL	23 - 16	90201-06M62	16 - 22	90464-10M60	16 - 8		9 - 4
60R-E2171-00	8 - 2	60R-G2710-00-4D	14 - 1	68R-W8180-00	26 - 1	90201-06M94	8 - 6	90465-08M83	6 - 16		10 - 24
60R-E2414-A0	2 - 9	60S-G2717-00	14 - 19	60R-WE09A-00-1S	4 - 1	90201-10M01	23 - 12	90465-08M99	6 - 15		12 - 5
	28 - 10		21 - 2	60R-WE09B-00-1S	2 - 1	90201-10M02	15 - 13		12 - 23		14 - 8
60R-E2481-00	2 - 11	60R-G2724-00	14 - 16	90101-06M18	18 - 12		23 - 18	90465-11M10	2 - 12		16 - 24
60S-E2481-00	14 - 27	60R-G2741-00	14 - 20	90105-06M07	19 - 5	90201-10M20	25 - 3		9 - 11		17 - 6
60R-E2482-00	2 - 17	60R-G3111-00-4D	18 - 1	90105-06M14	8 - 4	90201-10M63	25 - 8		11 - 9		19 - 16
60R-E2483-00	6 - 14	60R-G3112-00-4D	18 - 2	90105-08M36	4 - 6	90201-12472	11 - 12		12 - 16		22 - 18
60R-E3434-00	1 - 14	6L8-G3118-01	18 - 3	90105-08M78	4 - 7	90201-13201	8 - 5		14 - 28		26 - 25
60R-E3437-61	10 - 30	60R-G3311-00-4D	18 - 19	90109-06M81	14 - 12	90201-15M89	22 - 44		26 - 33		27 - 6
60R-E3444-50	14 - 39	60R-G3311-10-4D	18 - 19		16 - 7	90202-36M55	15 - 19	90465-12M56	26 - 29	92995-08600	17 - 19
60R-E3641-20-1S	6 - 1	60R-G3616-00	18 - 21	90109-06M84	18 - 38	90206-10M24	18 - 39	90467-09M05	22 - 37		20 - 10
60R-E3646-A0	6 - 8	60R-G3631-00	18 - 20	90109-06M86	10 - 27	90206-36M21	15 - 18	90467-09M09	9 - 6		21 - 23
	28 - 14	60R-G4111-00	16 - 1		16 - 12	90243-04M01	18 - 4	90467-11M08	21 - 8		23 - 5
60R-E4440-00	6 - 10	60R-G4111-10	17 - 8	90116-08015	15 - 22	90266-04M04	1 - 5	90468-18001	16 - 14		26 - 19
60R-E4711-00-5B	20 - 2	60R-G4143-00	16 - 13	90116-08M54	19 - 11	90269-02M09	15 - 11	90468-18008	17 - 13	93101-11M23	22 - 31
60R-E5100-00-1S	2 - 2	60R-G4143-10	16 - 13	90116-10019	15 - 25	90280-03M01	8 - 12	90480-06M19	14 - 17		30 - 10
60R-E5311-00-5B	21 - 12	60R-G4150-00	22 - 35	90119-06012	19 - 20		28 - 12	90480-10627	8 - 14	93101-12M70	21 - 6
60R-E5316-00	21 - 16	60R-G4555-00	19 - 19	90119-06013	19 - 21	90280-04M06	11 - 10	90480-14M54	20 - 4		30 - 2
69M-E5363-00	4 - 22	60R-G4557-00	19 - 18	90119-06014	11 - 6	90340-08002	22 - 9	90480-21M82	14 - 3	93101-15074	22 - 14
60R-E571Y-60	15 - 29	60R-G5111-00-4D	20 - 1	90119-06049	4 - 8	90340-10M10	21 - 14	90480-25161	12 - 9		30 - 6
60R-F4329-00	9 - 2	60R-G5111-10-4D	20 - 1	90119-06MA1	11 - 8	90386-08032	15 - 15	90501-12M05	22 - 49	93101-25M69	3 - 2
6N0-F8176-00	14 - 41	60R-G5181-00	21 - 3	90119-06MA2	2 - 10	90386-22MA4	18 - 8	90501-12M40	5 - 11		28 - 8
60R-F8199-72-D0	9 - 35	60R-G5300-00-4D	22 - 1	90119-06MA3	2 - 16	90386-30048	19 - 8	90501-23800	15 - 14	93102-18M21	8 - 1
60R-F8199-72-E0	9 - 35	60R-G5300-10-4D	22 - 1		6 - 5	90386-30M60	19 - 10	90502-10M07	18 - 18		28 - 2
60R-F8199-72-F0	9 - 35	60R-G5311-00-4D	22 - 2	90119-06MA5	6 - 4	90386-33M96	15 - 20	90506-18M41	18 - 27	93102-30M22	3 - 1

NUMERICAL INDEX
INDEX NUMERIQUE

PART NO. N° PIECES	REF. NO.	PART NO. N° PIECES	REF. NO.	PART NO. N° PIECES	REF. NO.	PART NO. N° PIECES	REF. NO.	PART NO. N° PIECES	REF. NO.	PART NO. N° PIECES	REF. NO.
93102-30M22	28 - 7	97095-05014	1 - 8								
93210-06ME6	22 - 33	97095-05016	16 - 3								
	30 - 12		17 - 10								
93210-12327	16 - 2	97095-06008	20 - 6								
	17 - 9	97095-06010	6 - 17								
93210-12M62	21 - 10		14 - 36								
93210-13M63	4 - 21		26 - 23								
	28 - 6	97095-06012	12 - 6								
93210-16275	25 - 10		14 - 7								
93210-20M65	9 - 27		16 - 25								
	28 - 18		17 - 5								
93210-24M79	4 - 23		26 - 27								
	28 - 17		27 - 5								
93210-29M94	19 - 9	97095-06016	22 - 17								
93210-31MJ5	6 - 11	97095-06020	4 - 12								
	28 - 15		10 - 23								
93210-44398	22 - 24		12 - 4								
	30 - 9	97095-06025	9 - 3								
93210-49046	22 - 15		12 - 10								
	30 - 7	97095-06030	8 - 17								
93210-53M08	22 - 16		9 - 24								
	30 - 8	97095-06045	16 - 23								
93306-004YH	22 - 5	97095-08014	21 - 4								
93430-04M03	18 - 34	97095-08016	26 - 18								
93450-15023	3 - 10	97575-06514	20 - 3								
93604-12M07	20 - 8	97595-06585	6 - 13								
	21 - 20	97780-40512	12 - 3								
	22 - 26	97780-60516	1 - 3								
	23 - 3	97880-05025	4 - 19								
93606-19M23	21 - 11	97885-05008	20 - 7								
93700-06M03	19 - 1		21 - 18								
94702-00274	4 - 24	97885-05012	15 - 4								
95380-04600	9 - 23	97885-06030	14 - 21								
95380-06600	14 - 24	97980-04112	7 - 4								
	17 - 7		29 - 7								
95380-06700	16 - 16	98507-04010	4 - 16								
	18 - 14	99001-07600	22 - 38								
95380-08600	19 - 14	99080-05600	18 - 25								
95895-06016	22 - 7	99510-10114	4 - 5								
97075-06025	19 - 15										
97075-08030	21 - 22										
97075-08035	17 - 18										
	20 - 9										
	23 - 4										
97080-08025	22 - 34										
97080-08045	22 - 27										
	30 - 20										
97095-05010	11 - 7										