



Back Home™

# MOSQUITO DELETO™ 2200 SYSTEM

## *Instructions for use*

Patent Nos. 5,205,064; 5,799,436;  
6,055,766; D466578; D468389

U.S. and other Patents Pending

© 2002 The Coleman Company, Inc.  
[www.coleman.com](http://www.coleman.com)

### **IMPORTANT**

Read this manual carefully before assembling, using or servicing this unit. Keep this manual for future reference. If you have questions about assembly, operation, servicing or repair, please call Coleman at 1-800-835-3278 or TDD: 316-832-8707.

For Outdoor use only

**GAS-FIRED**



**LISTED**

**8FA3**

**GAS-FIRED  
INSECT CONTROL  
EQUIPMENT**

Propane Tank & Battery  
Not Included

EPA Est. No.: 69269-KS-1

EPA Reg. No.: 70909-3-69269 (Octenol)

EPA Reg. No.: 70909-2-69269 (Linalool)



## Contents

Introduction .....	2
General Safety Information .....	2 & 3
System Description .....	3
Assembly .....	4 - 7
Leak Check .....	6
Operation .....	7
Moving Unit .....	8
Placement .....	8 & 9
Helpful Hints .....	9
Storage .....	9
Maintenance .....	9
Troubleshooting .....	10
Service .....	10
Mosquito Deleto™ Refills .....	10
Replacement Parts .....	11
Guarantees .....	12
Warranty .....	12

## Introduction

### • Mosquito Deleto™ System

- No zapping
- No lotions
- No sprays
- No electrical cords
- Mosquitoes have highly developed senses for detecting humans and animals.  
Mosquitoes are attracted to three things:
  - carbon dioxide from breath
  - body heat
  - faint odors emitted by animals and humans.
- The Mosquito Deleto™ Trap lures mosquitoes to it by emitting heat, carbon dioxide and a special mosquito attractant called Octenol. The Mosquito Deleto™ Inhibitor emits and circulates a patented scent that inhibits mosquitoes' ability to detect humans.
- The irresistible combination attracts mosquitoes to the trap where they are captured. . .never to bother you again!
- This instruction manual will assist you in setting up your new Mosquito Deleto™ System. Please refer to the instructions included with the Inhibitor for details on use, storage, specifications.

## General Safety Information

This manual contains important information about the assembly, operation and maintenance of this product and system. General safety information is presented in these first few pages and is also located throughout the manual. Particular attention should be paid to information accompanied by the safety alert symbols: "⚠ DANGER", "⚠ WARNING", "⚠ CAUTION".

Keep this manual for future reference and to educate new users of this product. This manual should be read in conjunction with the labeling on the product.

Safety precautions are essential when any mechanical or propane fueled equipment is involved. These precautions are necessary when using, storing, and servicing. Using this equipment with the respect and caution demanded will reduce the possibilities of personal injury or property damage.

The following symbols shown below are used extensively throughout this manual. Always heed these precautions, as they are essential when using any mechanical or fueled equipment.

### ⚠ DANGER

DANGER indicates an imminently hazardous situation which, if not avoided, will result in death or serious injury.

## General Safety Information *cont.*

### ⚠ WARNING

WARNING indicates a potentially hazardous situation which, if not avoided, could result in death or serious injury.

### ⚠ CAUTION

CAUTION indicates a potentially hazardous situation which, if not avoided, may result in minor or moderate personal injury, or property damage.

### ⚠ WARNING: For Outdoor Use Only

### ⚠ WARNING

**Improper installation, adjustment, alteration, service or maintenance can cause injury or property damage. Read the instructions thoroughly before installing or servicing this equipment.**

### ⚠ DANGER

Failure to comply with the precautions and instructions provided with this mosquito trap can result in death, serious bodily injury and property loss or damage from hazards of fire, explosion, burn, asphyxiation, and/or carbon monoxide poisoning.

Only persons who can understand and follow the instructions should use or service this mosquito trap.

If you need assistance or information such as an instruction manual or labels, contact The Coleman Co., Inc.

### ⚠ WARNING

- This product is fueled by propane gas. Propane gas is invisible, odorless, and flammable. An odorant is normally added to help detect leaks and can be described as a "rotten egg" smell. The odorant can fade over time so leaking gas is not always detectable by smell alone.
- Propane gas is heavier than air and leaking propane will sink to the lowest level possible. It can be ignited by ignition sources including matches, lighters, sparks or open flames of any kind many feet away from the original leak. Use only propane gas set up for vapor withdrawal.
- Propane gas should be stored or used in compliance with local ordinances and codes or with ANSI/NFPA 58. Turn off propane when not in use.
- The propane tank must always be stored outdoors in a well-ventilated space. Never store propane tank in an enclosed area (house, garage, etc.). If unit is to be stored indoors, disconnect the propane tank for outdoor storage.

### ⚠ WARNING

Combustion by-products produced when using this product contain chemicals known to the State of California to cause cancer, birth defects, or other reproductive harm.

## ⚠ DANGER



### • CARBON MONOXIDE HAZARD

- This unit is a combustion appliance. All combustion appliances produce carbon monoxide (CO) during the combustion process. This product is designed to produce extremely minute, non-hazardous amounts of CO if used and maintained in accordance with all warnings and instructions.
- Carbon Monoxide (CO) poisoning produces flu-like symptoms, watery eyes, headaches, dizziness, fatigue and possibly death. You can't see it and you can't smell it. It's an invisible killer. If these symptoms are present during operation of this product **get fresh air immediately!**
- **For outdoor use only.**
- **Never use inside house, or other unventilated or enclosed areas. This unit consumes air (oxygen). Do not use in unventilated or enclosed areas to avoid endangering your life.**

## ⚠ WARNING



### • BURN HAZARD

- Unit is hot when being used. Use care when servicing.
- Keep out of reach of children.

## ⚠ CAUTION

### • SERVICE SAFETY

- Keep all connections and fittings clean. Make sure propane tank valve outlet is clean.
  - Inspect hose before use. Replace if there is evidence of abrasion or wear.
  - During setup, check all connections and fittings for leaks using soapy water. Never use a flame.
  - Use for mosquito control only. Never alter in any way or use with any device or part not expressly approved by Coleman.
- 
- You must provide propane gas and propane tank. Use a standard 20 lb. propane tank.
  - Use this mosquito trap only with a propane vapor withdrawal supply system. See Chapter 5 of the *Standard for Storage and Handling of Liquefied Petroleum Gas, ANSI/NFPA 58*. Your local library or fire department will have this book.
  - The hose assembly installed with the mosquito trap must be used.
  - The installation must conform with local codes, or in the absence of local codes, with National Fuel Gas Code, ANSI Z223.1.
  - A dented, rusted or damaged propane tank may be hazardous and should be checked by your tank supplier. Never use a propane tank with a damaged valve connection.
  - The propane tank must be constructed and marked in accordance with the specifications for LP gas cylinders of the U.S. Department of Transportation (DOT).



Standard 20 lb. tank

## System Description

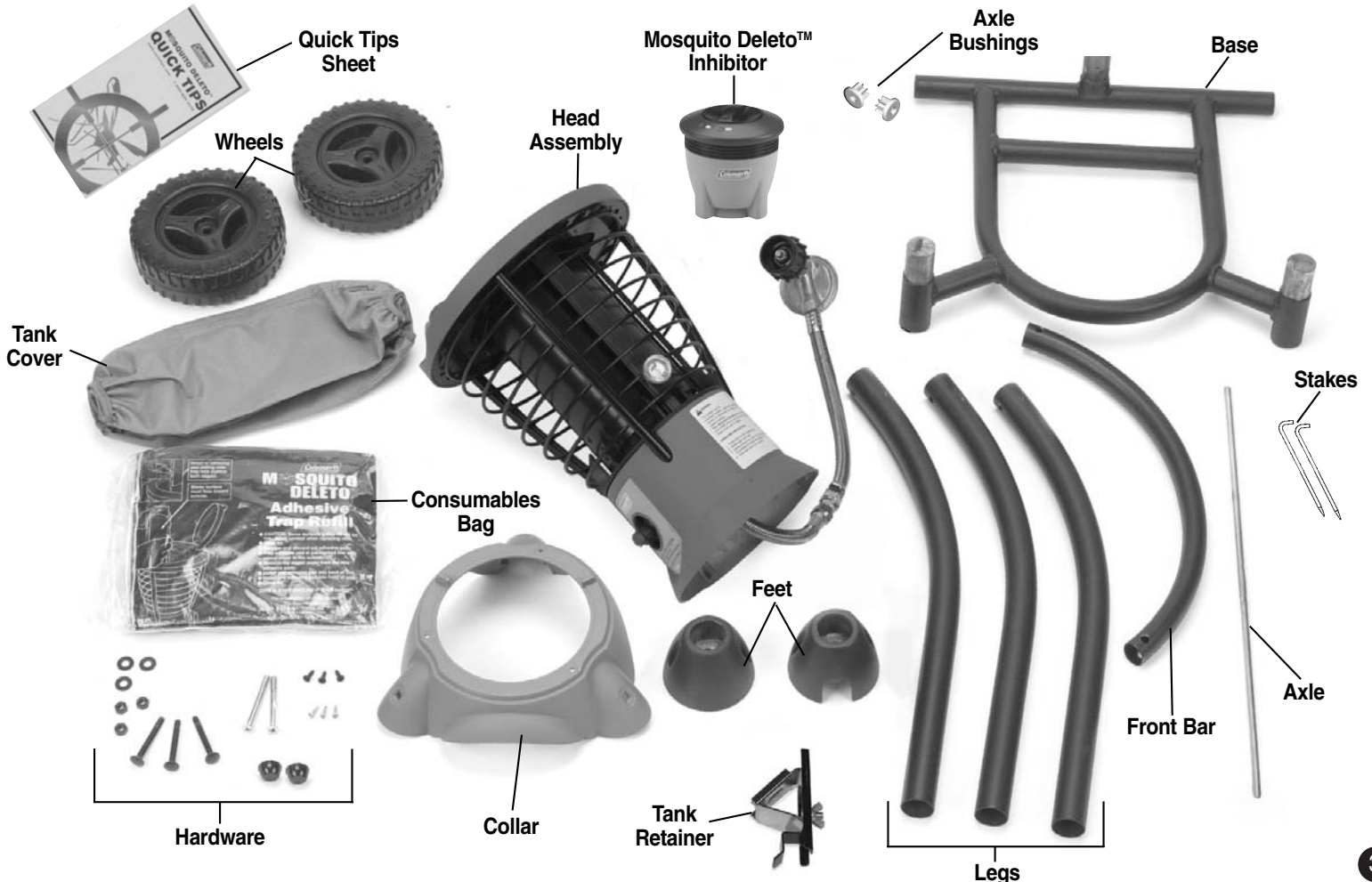

# Assembly

## Step 1

### TOOLS REQUIRED & OTHER ITEMS: (not provided)

- Standard Phillips head screwdriver
- 20# propane cylinder
- 7/16" end wrench
- One (1) AAA battery
- Lightweight hammer

- Remove all components from the package.
- See package label for listing of contents for the model you purchased.



## Step 2

- With a lightweight hammer, tap Axle Bushings into Base. Make sure Bushings are fully seated.

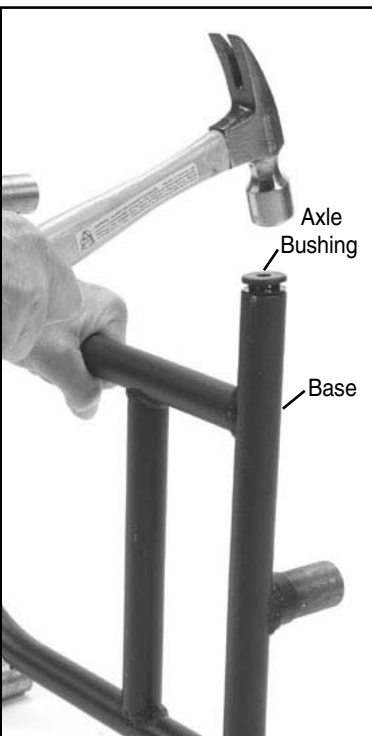

- Axle Bushings will receive the Axle for the Wheels.

## Step 3

- Insert Axle through one Wheel and then insert Axle through Axle Bushings. (Make sure side of tire with recessed area on hub is to the outside.)
- Insert Axle through second wheel & cap both ends with Retainer Nuts.
- To properly seat Retainer Nuts, gently tap with a hammer & support the bottom of Axle.

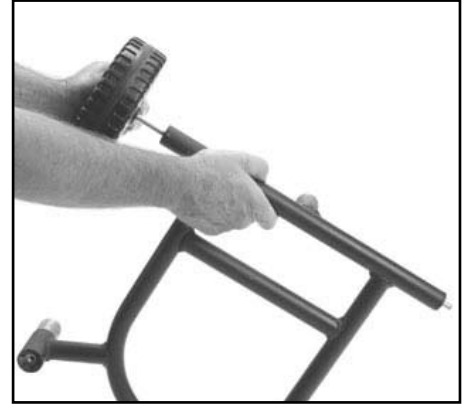

## Step 4

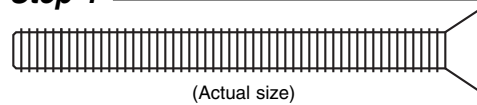

- Set both feet on base.



- Install front bar in feet.



- Assemble feet to base using hardware illustrated.



## Assembly *cont.*

### Step 5

- Turn the Base over.
- Install legs to base. All Legs are identical.
- Do not install screws until Step 7.

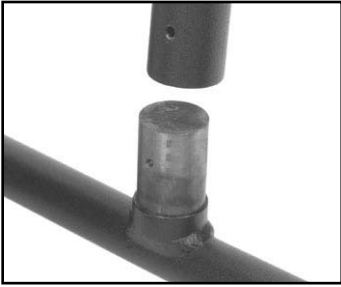

### Step 6

- Turn Head Assembly over while holding Lid closed.
- Attach Collar to Head Assembly.
- Align ribs on Collar with Ignitor.

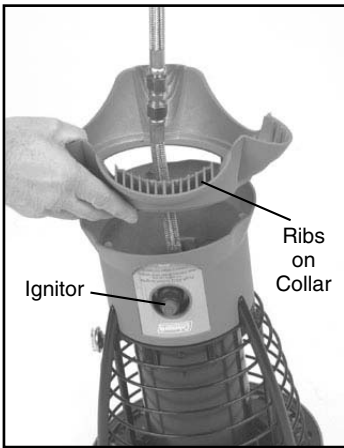

- Install screws and tighten.

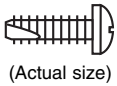

### Step 7

- Turn Head Assembly over while holding lid closed.
- Set Head Assembly on legs with Handle positioned as shown.



### Step 7 *cont.*



- Install Tank Retainer at Leg position opposite the Handle Grip.

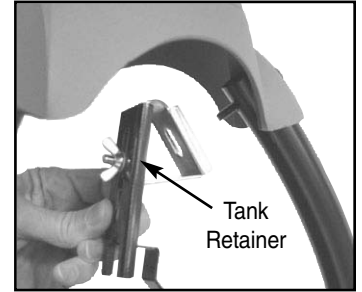

- Install Carriage Bolts, Washers, Nuts.

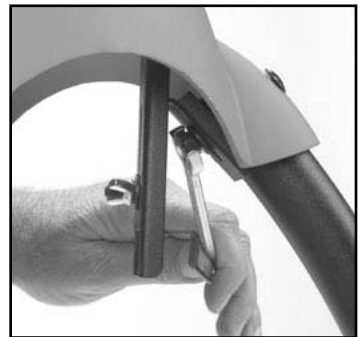

- Install Retaining Screws at bottom of Legs.

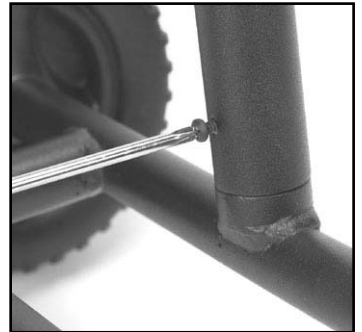
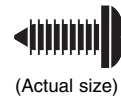

- Tighten Retaining Screws and Nut on the Tank Retainer.

- Unit is now prepared for tank installation.



**Step 9**

- Install Tank Cover.



- Set tank in unit with open side of Tank Ring facing front of Mosquito Deleto.

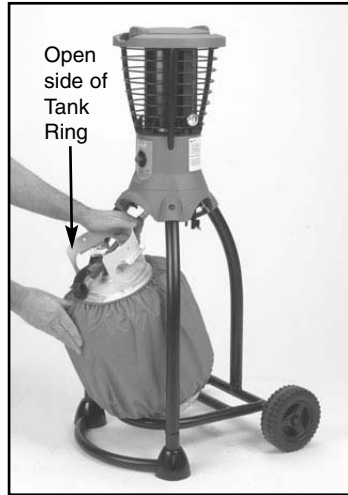

**Step 10**

- Set Tank Retainer on ring of Propane Tank.
- Tighten thumb screw securely.

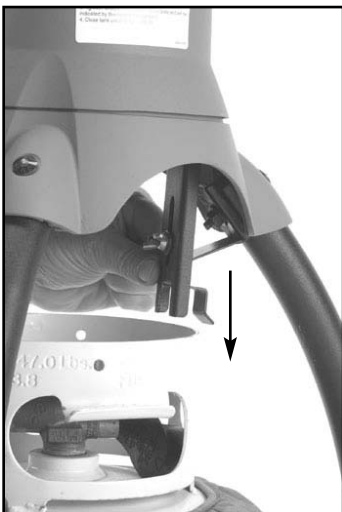

**IMPORTANT:** Be sure Tank Retainer is secure before moving the unit.

**Step 11**

- Attach hose to tank.



**Leak Check**

**⚠ WARNING**

- Perform leak test outdoors.
- Extinguish all open flames.
- NEVER leak test when smoking.
- Do not use the mosquito trap until connection has been leak tested and does not leak.

- Make 2-3 oz. of leak check solution (one part liquid dish-washing detergent and three parts water).
- Apply several drops of solution at Hose/Cylinder Connection.
- Turn Cylinder Valve ON.

**If bubbles appear at connection, there is a leak.**

- Turn Cylinder Valve OFF.
- Disconnect, reconnect, and perform another leak check. If you continue to see bubbles after several attempts, cylinder valve or hose is defective and should be replaced. Defective cylinders should be returned to cylinder's place of purchase.

**If NO bubbles appear at connection, the connection is secure.**

- Turn Cylinder Valve OFF.

**Hose/Cylinder Connection**

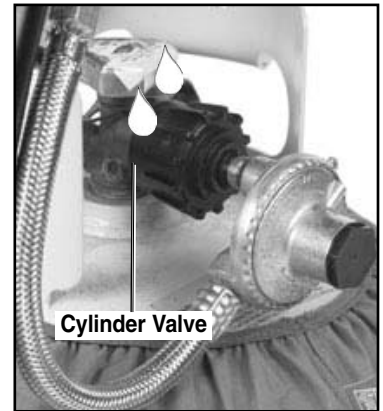

**NOTE:** Whenever gas connection is loosened or removed, you must perform a leak test.

**⚠ CAUTION**

Do not tamper with the regulator or use any substitute regulator.

**Step 12**

- Unscrew Ignitor Button.
  - Insert one (1) AAA battery then replace Ignitor Button and tighten.
- IMPORTANT:** Make sure positive (+) end of battery is facing towards the front of the unit as shown.

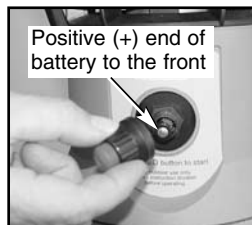

## Assembly *cont.*

### Step 13

#### ⚠ CAUTION

Contents of octenol cartridge are harmful if swallowed. Wash hands before eating, drinking, chewing gum, using tobacco or using bathroom facilities. Avoid contact with inside surface of foil package.

- Remove Mosquito Deleto™ octenol lure refill from foil package.



- Install lure into unit with holes facing center of trap.



### Step 14

- Remove the waxed paper from the adhesive trap.



- Install one adhesive trap into back of unit and one adhesive trap into front of unit.

*Note: Adhesive surface must face toward outside.*



#### Helpful Tip:

On hot days, the waxed paper will remove easily if the adhesive trays are cool. Store traps indoors.

- Photos below show detail of adhesive trap sliding over tray rails (typical both edges).



### Step 15

- Unit may be secured by driving stakes through holes in feet.



### Operation

#### ⚠ DANGER



##### • CARBON MONOXIDE HAZARD

- For outdoor use only. Never use inside house, or other unventilated or enclosed areas. This unit consumes air (oxygen). Do not use in unventilated or enclosed areas to avoid endangering your life.

#### ⚠ DANGER



##### • EXPLOSION - FIRE HAZARD

- Never store propane near high heat, open flames, pilot lights, direct sunlight, other ignition sources or where temperatures exceed 120 degrees F (49°C).
- Propane is heavier than air and can accumulate in low places. If you smell gas, leave the area immediately.
- Never install or remove propane tank while unit is operating, near flame, pilot lights, other ignition sources or while unit is hot to touch.
- This unit is hot during use and can ignite flammables. Keep gasoline and other flammable liquids and vapors well away from unit.
- The propane tank must always be stored outdoors in a well-ventilated space. Never store propane tank in an enclosed area (house, garage, etc.). If unit is to be stored indoors, disconnect the propane tank for outdoor storage.
- Do not attempt to operate until you have read & understand all General Safety Information in this manual, all assembly is complete and leak checks have been performed.
- After lighting the unit for the first time it is normal to see some smoke coming from the burner area. This smoke is the result of the burning of residual oils from the manufacturing process. The smoke will disappear within 10-15 minutes.

### To Turn On

#### ⚠ CAUTION

Unit cannot be match lit. Do not attempt.

- Slowly open Tank Valve.
- Allow system to fill for approximately 60 seconds.
- Press and hold Red Ignitor Button.
- Ignition should occur within 30 seconds and will be indicated by thermometer movement.



## To Turn On *cont.*

- Verify ignition by observing gauge:



## ⚠ CAUTION

If the needle enters the red zone (HOT) on the gauge, immediately turn off the unit & call Coleman at 1-800-835-3278.



- Repeat this process each time you restart of the unit.

## To Turn Off

- Turn cylinder valve OFF.

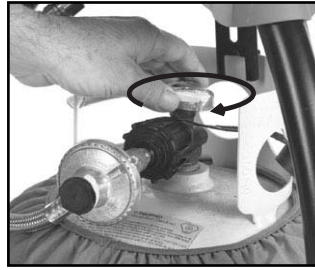

- Allow to cool for approximately 45 minutes before replacing lure or adhesive trap.

## Approximate Consumable Usage

- Propane: 40 days.
- Octenol Lure Refill: 1 month.
- Adhesive Trap: Approximately 2 weeks or when full.

## To Move Unit

- Unit can be moved from location to location by using the handle on the unit as shown.



## Proper Inhibitor and Trap Placement

1. Placement of the trap – find an area of your yard that is shaded, cool, or well protected by brush. Refer to the *Quick Tips Sheet*.
2. Mosquitoes breed in standing water or areas that become flooded with water during rain storms. Mosquitoes will also take cover under low lying brush to stay cool on warm days.
3. The trap should be placed in an area away from where people gather. We recommend a distance of at least 50 feet away from people.
4. Positioning of the device is very important. If you are not

catching mosquitoes, move the unit to another area of the yard that is protected from wind and direct sun and is near water. Try each location for a minimum of 2 days.

5. The Trap is designed to operate around the clock in your yard. The Trap continuously attracts, traps, and kills mosquitoes all day and all night.
6. Together, the Mosquito Deleto™ Inhibitor and Trap are a strong defense against mosquitoes!
7. Place the inhibitor unit per instructions in the inhibitor package.





## How To Use Mosquito Deleto™ Products:

1. Use the Mosquito Deleto™ Inhibitor to push mosquitoes away from you. . .use the Mosquito Deleto™ Trap to attract and kill mosquitoes!
2. The Mosquito Deleto™ Inhibitor is designed for occasional use. Turn it on when going outdoors to gently disperse the scent that blocks the mosquitoes' sensors. Turning the unit off will close the vents and preserve the unit for future use.
3. The Mosquito Deleto™ Inhibitor unit should be placed near where people gather. If there is a gentle breeze, be sure to place the inhibitor upwind from where people gather to be sure the scent covers the area desired.
4. During days of gusty winds (over 20 miles an hour), you should recheck the Mosquito Deleto™ Trap to be sure that the trap burner has not blown out.

## Helpful Hints

1. Did you know that only female mosquitoes bite? Female mosquitoes need protein to breed and lay eggs.
2. Mosquito eggs need water to hatch. Stopping adult female mosquitoes from breeding will help to reduce your problem with mosquitoes.
3. Mosquitoes can also be good fliers. While most mosquitoes do not migrate far from where they breed, some mosquitoes can fly up to 75 miles.
4. Mosquitoes also bite primarily in the evening and morning hours, when it is cooler. Some types of mosquitoes bite during the day. All mosquitoes like the temperature to be warm and generally humid, but not hot. During very hot days, mosquitoes will hide in the brush to stay cool.
5. Mosquitoes will also take cover from winds greater than 10 miles an hour.
6. Clearing your yard of standing water will help to reduce the number of mosquitoes breeding in your area. Remove all standing water in buckets, tires, and plant trays. Make sure that areas in your yard do not become flooded with standing water. All ponds and bird baths should have water cleaned frequently or water should be circulated to prevent mosquitoes from breeding.

## Storage

### **Disconnect mosquito trap from propane tank before long-term storage of either the cylinder or the mosquito trap.**

1. Turn cylinder valve off.
2. Disconnect hose from cylinder.
3. Separate tank from unit.
4. Remove AAA battery from Ignitor.
5. Store propane tank in safe manner. Refer to Chapter 5 of *Standard for Storage and Handling of Liquefied Gases, ANSI/NFPA 58*. Follow all local codes. Always store propane tanks outdoors.
6. Place mosquito trap in plastic bag or sealed box.
7. Store mosquito trap and base in a dry, clean, and safe place.

## **⚠ WARNING**



### **• BURN HAZARD**

- Do not touch or attempt any maintenance on unit for at least one hour after use.
- Make sure propane tank has been removed before doing maintenance.

## Maintenance

To enjoy years of outstanding performance from your mosquito trap perform the following maintenance activities on a regular basis:

- Keep exterior surfaces clean.
- Use warm soapy water for cleaning. Never use flammable or corrosive cleaning agents.
- While cleaning your unit, be sure to keep the area around the burner dry at all times.
- Air flow must be unobstructed. Keep controls, burner, and circulating air passages clean. Signs of possible blockage include:
  - Gas odor.
  - Mosquito trap makes popping noises.
  - Smoky exhaust.
- It is a good practice to remove leaves or trash that may collect in or near the cage.
- Spiders and insects can nest in unit. This condition can cause malfunctions. When trap is not in use, store in plastic bag or sealed box. (See Storage Instructions.) Compressed air may help clear away small particles.
- If unit has been left uncovered and is wet from rain, yard sprinklers, etc., allow to dry (at least 30 minutes prior to use).
- In a salt-air environment (such as near an ocean), corrosion occurs more quickly than normal. Frequently check for corroded areas and clean or repair them promptly.

## Troubleshooting

<b>Burner won't light</b>	Cylinder valve is closed	Open valve
	Gas pressure is low	Turn Cylinder valve OFF and replace cylinder
	Air in gas line	Burner may take 20 seconds to light after a propane bottle has been connected
	Low gas pressure with Cylinder Valve fully open	Cylinder is empty. Replace cylinder
	Igniter fails	Replace AAA Battery
	Improper purging of new 20 lb. cylinder	Attach cylinder to other appliance (Grill) to purge air from line.
<b>Burner won't stay lit</b>	Gas pressure is low	Turn Cylinder valve OFF and replace cylinder
	Outdoor temperature is less than 40° F and tank is less than 1/4 full	Use a full cylinder
	Supply hose is bent or kinked	Straighten hose
<b>Adhesive Panels dripping</b>	Panels exposed to direct sunlight	Move out of direct sunlight. If desired, replace.

## Service

- Repair to gas passages and associated components should be done only by a qualified service person.
- Owner repair & service should be limited and performed only to the following:
  - Octenol Lure replacement
  - Adhesive Trap replacement
  - Cylinder replacement
  - Listed parts replacement (See Replacement Parts List)
  - Routine Cleaning

## Mosquito Deleto™ Refills

Mosquito Deleto™  
Octenol Lure Refill  
Model # 2960-601

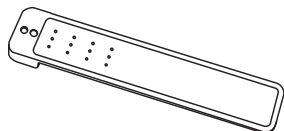

Mosquito Deleto™ Inhibitor  
Model # 2950-603

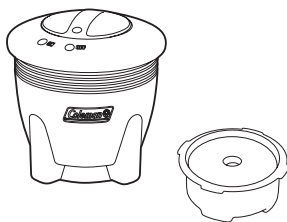

Mosquito Deleto™  
Trap Cartridge Refill  
Model # 2960-602

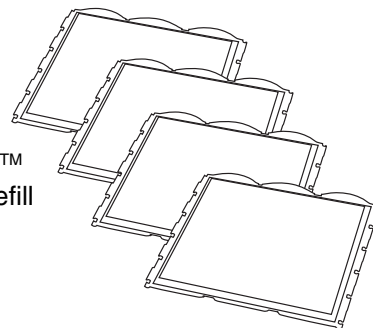

Mosquito Deleto™  
System Refill  
Model # 2950-700

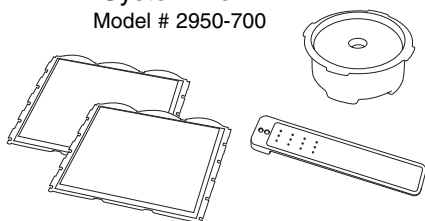

Mosquito Deleto™  
Inhibitor Refill  
Model # 2960-603

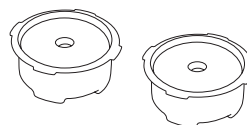

All Mosquito Deleto™ refills are available at [www.coleman.com](http://www.coleman.com) or 1-800-835-3278.

# Replacement Parts

## Parts List

No.	Part No.	Description
1	2950-1421	Cap Lift Grip
2	2910-5651	Cap Assembly
3	2950-2211	Rib (single component)
4	2910-0341	Igniter Assembly (no wires)
5	2910A0981	Thermometer
6	2910-3581	Transition Piece w/3 bolts
7	2910-0801	1 Individual Leg
8	2910-3601	Axle & 2 Wheels
9	2910-3591	Base Assembly (D-ring, 2 Feet, Support Bar, Hardware)
10	2910-0931	Tank Holder Assembly
11	2950-3701	Tank Cover
12	2910-8001	Head Assembly
13	2910-0311	Ignitor Button
14	2910-0371	Gas Tip

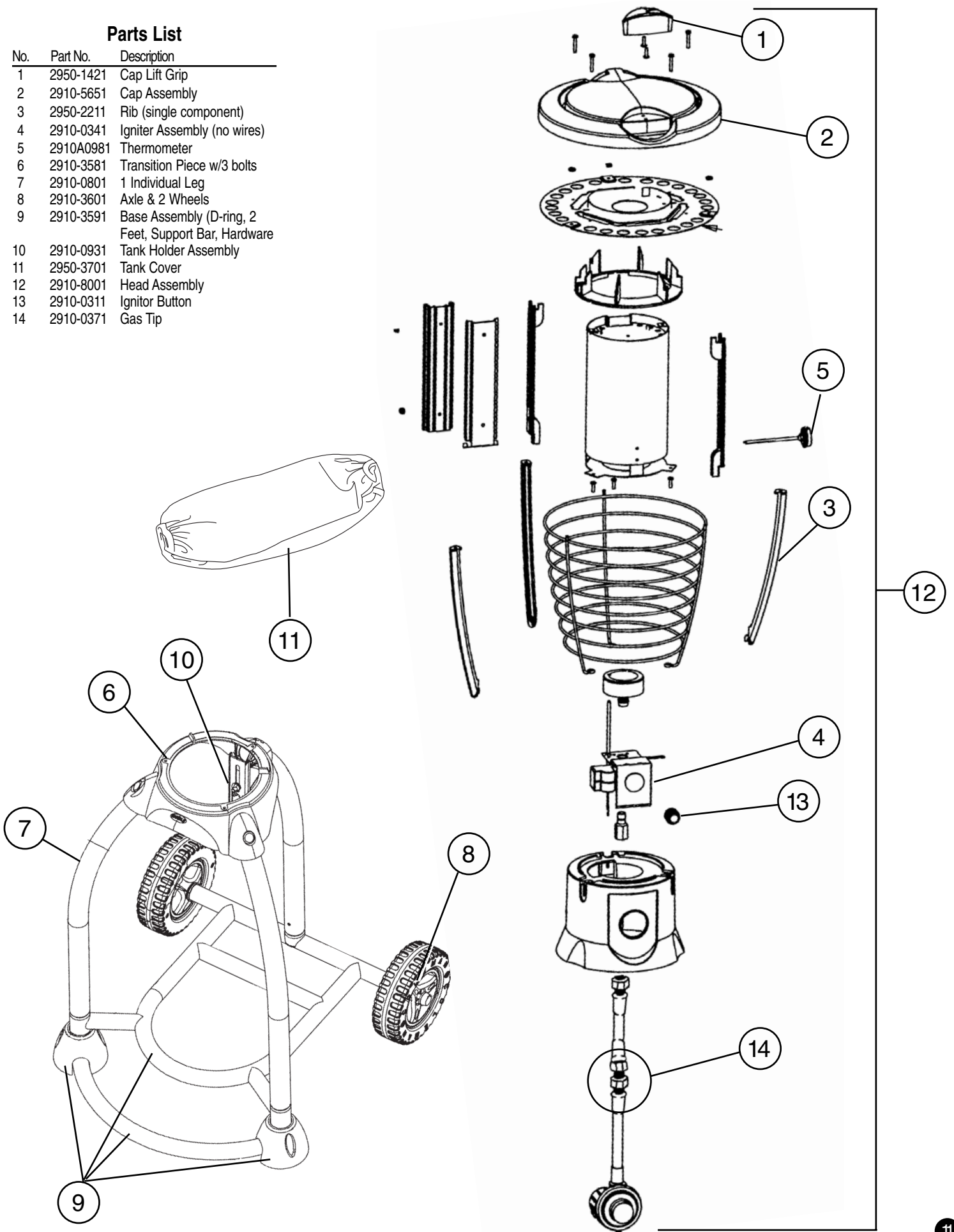

# Guarantee

## Inhibitor

- Guaranteed to repel mosquitoes.

### Limited 60 Day Guarantee

Thank you for purchasing a Coleman® Mosquito Deleto™. The Coleman Company, Inc. ("Coleman") guarantees that this product will repel mosquitoes when used as directed, during mosquito season. If for any reason you are not completely satisfied with this product during the first 60 days after you purchase the Mosquito Deleto™, contact Coleman for a full refund. Proof of purchase shall be required to establish the purchase date. This warranty is valid only for the original retail purchaser and is not transferable. Coleman does not guarantee to eliminate mosquitoes, to trap mosquitoes during winter months or periods of cold weather, or to prevent mosquito bites. Follow all instructions and recommendations. If you have questions, contact Coleman at 1-800-835-3278 or www.coleman.com.

## Trap

- Guaranteed to trap & kill mosquitoes.

### Limited 60 Day Guarantee

Thank you for purchasing a Coleman® Mosquito Deleto™. The Coleman Company, Inc. ("Coleman") guarantees that this product will trap and kill mosquitoes when used as directed, during mosquito season. If for any reason you are not completely satisfied with this product during the first 60 days after you purchase the Mosquito Deleto™, contact Coleman for a full refund. Proof of purchase shall be required to establish the purchase date. This warranty is valid only for the original retail purchaser and is not transferable. Coleman does not guarantee to eliminate mosquitoes, to trap mosquitoes during winter months or periods of cold weather, or to prevent mosquito bites. Follow all instructions and recommendations. If you have questions, contact Coleman at 1-800-835-3278 or www.coleman.com.

# Warranty

## 1 Year Limited Warranty

The Coleman Company, Inc. ("Coleman") warrants that for a period of one year from the date of purchase, this product will be free from defects in material and workmanship. Coleman, at its option, will repair or replace this product or any component of the product found to be defective during the warranty period. Replacement will be made with a new or remanufactured product or component. If the product is no longer available, replacement may be made with a similar product of equal or greater value. This is your exclusive warranty.

This warranty is valid for the original retail purchaser from the date of initial retail purchase and is not transferable. Keep the original sales receipt. Proof of purchase is required to obtain warranty performance. Coleman dealers, service centers, or retail stores selling Coleman products do not have the right to alter, modify or in any way change the terms and conditions of this warranty.

This warranty does not cover normal wear of parts, including chips, scratches, abrasions, discoloration or fading from use or exposure to sunlight or damage resulting from any of the following: negligent use or misuse of the product, use on improper voltage or current, use of non-Coleman accessories or parts, use contrary to the operating instructions or failure to follow maintenance instructions, commercial, in profit or non-profit instructional or rental applications, disassembly, repair or alteration by anyone other than Coleman or an authorized service center. Further, the warranty does not cover Acts of God, such as fire, flood, hurricanes and tornadoes.

Coleman shall not be liable for any incidental or consequential damages caused by the breach of any express or implied warranty. Except to the extent prohibited by applicable law, any implied warranty of merchantability or fitness for a particular purpose is limited in duration to the duration of the above warranty. Some states, provinces or jurisdictions do not allow the exclusion or limitation of incidental or consequential damages or limitations on how long an implied warranty lasts, so the above limitations or exclusion may not apply to you. This warranty gives you specific legal rights, and you may also have other rights that vary from state to state or province to province.

### How to Obtain Warranty Service

Take the product to an authorized Coleman service center. You can find the nearest authorized Coleman service center by calling 1-800-835-3278 or TDD 316-832-8707. If a service center is not conveniently located, attach a tag to the product that includes your name, address, daytime telephone number and description of the problem. Include a copy of the original sales receipt. Carefully package the product and send either by UPS or Parcel Post INSURED with shipping and insurance prepaid to:

For products purchased in the United States:

The Coleman Company, Inc.  
3600 North Hydraulic  
Wichita, KS 67219

Do not mail products with fuel in tanks, or with disposable propane cylinders.

DO NOT RETURN THIS PRODUCT TO THE PLACE OF PURCHASE.

If you have any questions regarding this warranty please call 1-800-835-3278 or TDD 316-832-8707.



## Mosquito Deleto™ Octenol Lure Refill

**Active Ingredient:**  
1-Octen-3-ol\* 24.5%  
**Other Ingredients:** 75.5%  
**Total** 100.00%

\*Contains 3.72 grams Octenol per lure.

EPA Reg. No. 70909-3-69269  
EPA Est. No. 69269-KS-1

### Keep Out of Reach of Children

#### CAUTION

#### FIRST AID

If on skin or clothing	<ul style="list-style-type: none"> <li>• Take off contaminated clothing.</li> <li>• Rinse skin immediately with plenty of water for 15 - 20 minutes.</li> <li>• Call a poison control center or doctor for treatment advice.</li> </ul>
If in eyes	<ul style="list-style-type: none"> <li>• Hold eye open and rinse slowly and gently with water for 15 - 20 minutes.</li> <li>• Remove contact lenses, if present, after the first 5 minutes, then continue rinsing eye.</li> <li>• Call a poison control center or doctor for treatment advice.</li> </ul>
If inhaled	<ul style="list-style-type: none"> <li>• Move person to fresh air.</li> <li>• If person is not breathing, call 911 or an ambulance, then give artificial respiration, preferably by mouth-to-mouth, if possible.</li> <li>• Call a poison control center or doctor for further treatment advice.</li> </ul>
If swallowed	<ul style="list-style-type: none"> <li>• Call poison control center or doctor immediately for treatment advice.</li> <li>• Have person sip a glass of water if able to swallow.</li> <li>• Do not induce vomiting unless told to do so by the poison control center or doctor.</li> <li>• Do not give anything by mouth to an unconscious person.</li> </ul>
Have the product container or label with you when calling a poison control center or doctor, or going for treatment.	

#### Storage and Disposal:

Store this product in a cool, dry place and out of the reach of children until ready to use. Dispose of the used attractant lure by wrapping it in several layers of newspaper and dispose in the trash.

**Directions for use:** It is a violation of Federal law to use this product in a manner inconsistent with its labeling.

### PRECAUTIONARY STATEMENTS

#### Hazards to Humans and Domestic Animals

**Caution:** Harmful if swallowed. Wash hands before eating, drinking, chewing gum, using tobacco or using bathroom facilities. Avoid contact of areas under foil wrapper with skin and eyes.

Manufactured for:  
The Coleman Co., Inc. • 3600 N. Hydraulic • Wichita, KS 67219  
www.coleman.com  
1-800-835-3278 TDD: 1-316-832-8707



The Coleman Co., Inc.  
3600 N. Hydraulic  
Wichita, KS 67219 U.S.A.  
1-800-835-3278  
TDD: 316-832-8707  
www.coleman.com