



400 TS

ARCMASTER® INVERTER ARC WELDER



Art # A-07263

Operating Manual

Version: AB

Issue Date: February 20, 2013 Manual No: 0-4902

Operating Features:





WE APPRECIATE YOUR BUSINESS!

Congratulations on your new Thermal Arc product. We are proud to have you as our customer and will strive to provide you with the best service and reliability in the industry. This product is backed by our extensive warranty and world-wide service network. To locate your nearest distributor or service agency call 1-800-752-7621, or visit us on the web at www.thermalarc.com.

This Operating Manual has been designed to instruct you on the correct use and operation of your Thermal Arc product. Your satisfaction with this product and its safe operation is our ultimate concern. Therefore please take the time to read the entire manual, especially the Safety Precautions. They will help you to avoid potential hazards that may exist when working with this product.

YOU ARE IN GOOD COMPANY!

The Brand of Choice for Contractors and Fabricators Worldwide.

Thermal Arc is a Global Brand of Arc Welding Products for Thermadyne Industries Inc. We manufacture and supply to major welding industry sectors worldwide including; Manufacturing, Construction, Mining, Automotive, Aerospace, Engineering, Rural and DIY/Hobbyist.

We distinguish ourselves from our competition through market-leading, dependable products that have stood the test of time. We pride ourselves on technical innovation, competitive prices, excellent delivery, superior customer service and technical support, together with excellence in sales and marketing expertise.

Above all, we are committed to develop technologically advanced products to achieve a safer working environment within the welding industry.

WARNINGS

Read and understand this entire Manual and your employer's safety practices before installing, operating, or servicing the equipment.

While the information contained in this Manual represents the Manufacturer's best judgement, the Manufacturer assumes no liability for its use.

ArcMaster 400 TS Inverter Arc Welder
Instruction Manual Number 0-4902 for:
Part Number 10-3091

Published by:
Victor Technologies
82 Benning Street
West Lebanon, New Hampshire, USA 03784
(603) 298-5711

www.thermalarc.com

Copyright 2006, 2013 by
Victor Technologies

All rights reserved.

Reproduction of this work, in whole or in part, without written permission of the publisher is prohibited.

The publisher does not assume and hereby disclaims any liability to any party for any loss or damage caused by any error or omission in this Manual, whether such error results from negligence, accident, or any other cause.

Publication Date: April 26, 2006
Revision Date: February 20, 2013

Record the following information for Warranty purposes:

Where Purchased: _____

Purchase Date: _____

Equipment Serial #: _____

TABLE OF CONTENTS

SECTION 1. SAFETY INSTRUCTIONS AND WARNINGS	1
1.01 Arc Welding Hazards	1
1.02 Principal Safety Standards.....	4
1.03 Precautions de Securite en Soudage à l'Arc.....	5
1.04 Dangers Relatifs au Soudage à l'Arc	5
1.05 Principales Normes de Securite.....	8
1.06 Declaration of Conformity.....	9
 SYMBOL LEGEND	 11
 SECTION 2. INTRODUCTION AND DESCRIPTION	 12
2.01 How to Use This Manual.....	12
2.02 Equipment Identification.....	12
2.03 Receipt of Equipment	12
2.04 Description.....	13
2.05 Functional Block Diagram.....	14
2.06 Transporting Methods.....	14
 SECTION 3. INSTALLATION RECOMMENDATIONS	 15
3.01 Environment.....	15
3.02 Location	15
3.03 Electrical Input Connections	15
3.03.01 Electrical Input Requirements.....	16
3.03.02 Input Power.....	17
3.03.03 High Frequency Introduction	18
3.03.04 High Frequency Interference.....	18
3.04 Specifications.....	19
3.05 Duty Cycle	20
 SECTION 4. OPERATOR CONTROLS	 21
4.01 ArcMaster 400 TS Controls	19
4.02 Weld Process Selection for ArcMaster 400 TS	23
4.03 Weld Parameter Description.....	24
4.04 Weld Parameters for ArcMaster 400 TS	26
4.05 Power Source Features.....	27
 SECTION 5. SET-UP FOR SMAW (STICK) AND GTAW (TIG)	 29
 SECTION 6. SEQUENCE OF OPERATION.....	 30
6.01 Stick Welding	31
6.02 HF TIG & Lift TIG Welding.....	31
6.02.01 Slope Mode Sequence.....	32
6.02.02 Slope Mode with Repeat Sequence	32
6.02.03 Pulse Controls.....	33
6.03 Save-Load Operation.....	34

TABLE OF CONTENTS

SECTION 7. BASIC TIG WELDING GUIDE	35
7.01 Electrode Polarity	35
7.02 Tungsten Electrode Current Ranges	35
7.03 Tungsten Electrode Types	35
7.04 Guide for Selecting Filler Wire Diameter	36
7.05 Shielding Gas Selection	36
7.06 TIG Welding Parameters for Low Carbon & Low Alloy Steel Pipe	36
7.07 Welding Parameters for Steel	37
SECTION 8. BASIC ARC WELDING GUIDE	38
8.01 Electrode Polarity	38
8.02 Effects of Stick Welding Various Materials	38
SECTION 9. ROUTINE MAINTENANCE	40
SECTION 10. BASIC TROUBLESHOOTING	41
10.01 TIG Welding Problems	41
10.02 Stick Welding Problems	43
10.03 Power Source Problems	45
SECTION 11. VOLTAGE REDUCTION DEVICE (VRD)	47
11.01 VRD Specification.....	47
11.02 VRD Maintenance.....	47
11.03 Switching VRD ON/OFF	48
SECTION 12. POWER SOURCE ERROR CODES	50
APPENDIX A - INTERCONNECT DIAGRAM	53
APPENDIX B - ARCMaster 400 TS ACCESSORIES	55
LIMITED WARRANTY AND SCHEDULE	
GLOBAL CUSTOMER SERVICE CONTACT INFORMATION	Inside Rear Cover

SECTION 1: SAFETY INSTRUCTIONS AND WARNINGS



WARNING

PROTECT YOURSELF AND OTHERS FROM POSSIBLE SERIOUS INJURY OR DEATH. KEEP CHILDREN AWAY. PACEMAKER WEARERS KEEP AWAY UNTIL CONSULTING YOUR DOCTOR. DO NOT LOSE THESE INSTRUCTIONS. READ OPERATING/INSTRUCTION MANUAL BEFORE INSTALLING, OPERATING OR SERVICING THIS EQUIPMENT.

Welding products and welding processes can cause serious injury or death, or damage to other equipment or property, if the operator does not strictly observe all safety rules and take precautionary actions.

Safe practices have developed from past experience in the use of welding and cutting. These practices must be learned through study and training before using this equipment. Some of these practices apply to equipment connected to power lines; other practices apply to engine driven equipment. Anyone not having extensive training in welding and cutting practices should not attempt to weld.

Safe practices are outlined in the American National Standard Z49.1 entitled: SAFETY IN WELDING AND CUTTING. This publication and other guides to what you should learn before operating this equipment are listed at the end of these safety precautions. **HAVE ALL INSTALLATION, OPERATION, MAINTENANCE, AND REPAIR WORK PERFORMED ONLY BY QUALIFIED PEOPLE.**

1.01 Arc Welding Hazards



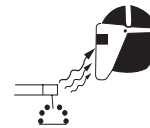
WARNING

ELECTRIC SHOCK can kill.

Touching live electrical parts can cause fatal shocks or severe burns. The electrode and work circuit is electrically live whenever the output is on. The input power circuit and machine internal circuits are also live when power is on. In semiautomatic or automatic wire welding, the wire, wire reel, drive roll housing, and all metal parts touching the welding wire are electrically live. Incorrectly installed or improperly grounded equipment is a hazard.

1. Do not touch live electrical parts.
2. Wear dry, hole-free insulating gloves and body protection.
3. Insulate yourself from work and ground using dry insulating mats or covers.
4. Disconnect input power or stop engine before installing or servicing this equipment. Lock input power disconnect switch open, or remove line fuses so power cannot be turned on accidentally.
5. Properly install and ground this equipment according to its Owner's Manual and national, state, and local codes.
6. Turn off all equipment when not in use. Disconnect power to equipment if it will be left unattended or out of service.

7. Use fully insulated electrode holders. Never dip holder in water to cool it or lay it down on the ground or the work surface. Do not touch holders connected to two welding machines at the same time or touch other people with the holder or electrode.
8. Do not use worn, damaged, undersized, or poorly spliced cables.
9. Do not wrap cables around your body.
10. Ground the workpiece to a good electrical (earth) ground.
11. Do not touch electrode while in contact with the work (ground) circuit.
12. Use only well-maintained equipment. Repair or replace damaged parts at once.
13. In confined spaces or damp locations, do not use a welder with AC output unless it is equipped with a voltage reducer. Use equipment with DC output.
14. Wear a safety harness to prevent falling if working above floor level.
15. Keep all panels and covers securely in place.



WARNING

ARC RAYS can burn eyes and skin; NOISE can damage hearing. Arc rays from the welding process produce intense heat and strong ultraviolet rays that can burn eyes and skin. Noise from some processes can damage hearing.

1. Wear a welding helmet fitted with a proper shade of filter (see ANSI Z49.1 listed in Safety Standards) to protect your face and eyes when welding or watching.
2. Wear approved safety glasses. Side shields recommended.

ARCMaster 400 TS

3. Use protective screens or barriers to protect others from flash and glare; warn others not to watch the arc.
4. Wear protective clothing made from durable, flame-resistant material (wool and leather) and foot protection.
5. Use approved ear plugs or ear muffs if noise level is high.



WARNING

FUMES AND GASES can be hazardous to your health.

Welding produces fumes and gases. Breathing these fumes and gases can be hazardous to your health.

1. Keep your head out of the fumes. Do not breathe the fumes.
2. If inside, ventilate the area and/or use exhaust at the arc to remove welding fumes and gases.
3. If ventilation is poor, use an approved air-supplied respirator.
4. Read the Material Safety Data Sheets (MSDSs) and the manufacturer's instruction for metals, consumables, coatings, and cleaners.
5. Work in a confined space only if it is well ventilated, or while wearing an air-supplied respirator. Shielding gases used for welding can displace air causing injury or death. Be sure the breathing air is safe.
6. Do not weld in locations near degreasing, cleaning, or spraying operations. The heat and rays of the arc can react with vapors to form highly toxic and irritating gases.
7. Do not weld on coated metals, such as galvanized, lead, or cadmium plated steel, unless the coating is removed from the weld area, the area is well ventilated, and if necessary, while wearing an air-supplied respirator. The coatings and any metals containing these elements can give off toxic fumes if welded.



WARNING

WELDING can cause fire or explosion.

Sparks and spatter fly off from the welding arc. The flying sparks and hot metal, weld spatter, hot workpiece, and hot equipment can cause fires and burns. Accidental contact of electrode or welding wire to metal objects can cause sparks, overheating, or fire.

1. Protect yourself and others from flying sparks and hot metal.
2. Do not weld where flying sparks can strike flammable material.
3. Remove all flammables within 35 ft (10.7 m) of the welding arc. If this is not possible, tightly cover them with approved covers.
4. Be alert that welding sparks and hot materials from welding can easily go through small cracks and openings to adjacent areas.
5. Watch for fire, and keep a fire extinguisher nearby.
6. Be aware that welding on a ceiling, floor, bulkhead, or partition can cause fire on the hidden side.
7. Do not weld on closed containers such as tanks or drums.
8. Connect work cable to the work as close to the welding area as practical to prevent welding current from traveling long, possibly unknown paths and causing electric shock and fire hazards.
9. Do not use welder to thaw frozen pipes.
10. Remove stick electrode from holder or cut off welding wire at contact tip when not in use.

Eye protection filter shade selector for welding or cutting (goggles or helmet), from AWS A6.2-73.					
Welding or cutting	Electrode Size	Filter	Welding or cutting	Electrode Size	Filter
Torch soldering		2	Gas metal-arc		
Torch brazing		3 or 4	Non-ferrous base metal	All	11
Oxygen Cutting			Ferrous base metal	All	12
Light	Under 1 in., 25 mm	3 or 4	Gas tungsten arc welding	All	12
Medium	1 to 6 in., 25-150 mm	4 or 5	(TIG)	All	12
Heavy	Over 6 in., 150 mm	5 or 6	Atomic hydrogen welding	All	12
Gas welding			Carbon arc welding	All	12
Light	Under 1/8 in., 3 mm	4 or 5	Plasma arc welding		
Medium	1/8 to 1/2 in., 3-12 mm	5 or 6	Carbon arc air gouging		
Heavy	Over 1/2 in., 12 mm	6 or 8	Light		12
Shielded metal-arc	Under 5/32 in., 4 mm	10	Heavy		14
	5/32 to 1/4 in.,	12	Plasma arc cutting		
	Over 1/4 in., 6.4 mm	14	Light	Under 300 Amp	9
			Medium	300 to 400 Amp	12
			Heavy	Over 400 Amp	14



WARNING

FLYING SPARKS AND HOT METAL can cause injury.

Chipping and grinding cause flying metal. As welds cool, they can throw off slag.

1. Wear approved face shield or safety goggles. Side shields recommended.
2. Wear proper body protection to protect skin.



WARNING

CYLINDERS can explode if damaged.

Shielding gas cylinders contain gas under high pressure. If damaged, a cylinder can explode. Since gas cylinders are normally part of the welding process, be sure to treat them carefully.

1. Protect compressed gas cylinders from excessive heat, mechanical shocks, and arcs.
2. Install and secure cylinders in an upright position by chaining them to a stationary support or equipment cylinder rack to prevent falling or tipping.
3. Keep cylinders away from any welding or other electrical circuits.
4. Never allow a welding electrode to touch any cylinder.
5. Use only correct shielding gas cylinders, regulators, hoses, and fittings designed for the specific application; maintain them and associated parts in good condition.
6. Turn face away from valve outlet when opening cylinder valve.
7. Keep protective cap in place over valve except when cylinder is in use or connected for use.
8. Read and follow instructions on compressed gas cylinders, associated equipment, and CGA publication P-1 listed in Safety Standards.



WARNING

Engines can be dangerous.



WARNING

ENGINE EXHAUST GASES can kill.

Engines produce harmful exhaust gases.

1. Use equipment outside in open, well-ventilated areas.

2. If used in a closed area, vent engine exhaust outside and away from any building air intakes.



WARNING

ENGINE FUEL can cause fire or explosion.

Engine fuel is highly flammable.

1. Stop engine before checking or adding fuel.
2. Do not add fuel while smoking or if unit is near any sparks or open flames.
3. Allow engine to cool before fueling. If possible, check and add fuel to cold engine before beginning job.
4. Do not overfill tank — allow room for fuel to expand.
5. Do not spill fuel. If fuel is spilled, clean up before starting engine.



WARNING

MOVING PARTS can cause injury.

Moving parts, such as fans, rotors, and belts can cut fingers and hands and catch loose clothing.

1. Keep all doors, panels, covers, and guards closed and securely in place.
2. Stop engine before installing or connecting unit.
3. Have only qualified people remove guards or covers for maintenance and troubleshooting as necessary.
4. To prevent accidental starting during servicing, disconnect negative (-) battery cable from battery.
5. Keep hands, hair, loose clothing, and tools away from moving parts.
6. Reinstall panels or guards and close doors when servicing is finished and before starting engine.



WARNING

SPARKS can cause BATTERY GASES TO EXPLODE; BATTERY ACID can burn eyes and skin.

Batteries contain acid and generate explosive gases.

1. Always wear a face shield when working on a battery.
2. Stop engine before disconnecting or connecting battery cables.
3. Do not allow tools to cause sparks when working on a battery.
4. Do not use welder to charge batteries or jump start vehicles.
5. Observe correct polarity (+ and -) on batteries.



WARNING

STEAM AND PRESSURIZED HOT COOLANT can burn face, eyes, and skin.

The coolant in the radiator can be very hot and under pressure.

1. Do not remove radiator cap when engine is hot. Allow engine to cool.
2. Wear gloves and put a rag over cap area when removing cap.
3. Allow pressure to escape before completely removing cap.



WARNING

This product, when used for welding or cutting, produces fumes or gases which contain chemicals known to the State of California to cause birth defects and, in some cases, cancer. (California Health & Safety code Sec. 25249.5 et seq.)

NOTE

Considerations About Welding And The Effects of Low Frequency Electric and Magnetic Fields

The following is a quotation from the General Conclusions Section of the U.S. Congress, Office of Technology Assessment, Biological Effects of Power Frequency Electric & Magnetic Fields - Background Paper, OTA-BP-E-63 (Washington, DC: U.S. Government Printing Office, May 1989): "...there is now a very large volume of scientific findings based on experiments at the cellular level and from studies with animals and people which clearly establish that low frequency magnetic fields interact with, and produce changes in, biological systems. While most of this work is of very high quality, the results are complex. Current scientific understanding does not yet allow us to interpret the evidence in a single coherent framework. Even more frustrating, it does not yet allow us to draw definite conclusions about questions of possible risk or to offer clear science-based advice on strategies to minimize or avoid potential risks."

To reduce magnetic fields in the workplace, use the following procedures:

1. Keep cables close together by twisting or taping them.
2. Arrange cables to one side and away from the operator.
3. Do not coil or drape cable around the body.
4. Keep welding power source and cables as far away from body as practical.

ABOUT PACEMAKERS:

The above procedures are among those also normally recommended for pacemaker wearers. Consult your doctor for complete information.

1.02 Principal Safety Standards

Safety in Welding and Cutting, ANSI Standard Z49.1, from American Welding Society, 550 N.W. LeJeune Rd., Miami, FL 33126.

Safety and Health Standards, OSHA 29 CFR 1910, from Superintendent of Documents, U.S. Government Printing Office, Washington, D.C. 20402.

Recommended Safe Practices for the Preparation for Welding and Cutting of Containers That Have Held Hazardous Substances, American Welding Society Standard AWS F4.1, from American Welding Society, 550 N.W. LeJeune Rd., Miami, FL 33126.

National Electrical Code, NFPA Standard 70, from National Fire Protection Association, Batterymarch Park, Quincy, MA 02269.

Safe Handling of Compressed Gases in Cylinders, CGA Pamphlet P-1, from Compressed Gas Association, 1235 Jefferson Davis Highway, Suite 501, Arlington, VA 22202.

Code for Safety in Welding and Cutting, CSA Standard W117.2, from Canadian Standards Association, Standards Sales, 178 Rexdale Boulevard, Rexdale, Ontario, Canada M9W 1R3.

Safe Practices for Occupation and Educational Eye and Face Protection, ANSI Standard Z87.1, from American National Standards Institute, 1430 Broadway, New York, NY 10018.

Cutting and Welding Processes, NFPA Standard 51B, from National Fire Protection Association, Batterymarch Park, Quincy, MA 02269.

1.03 Precautions de Sécurité en Soudage à l'Arc



MISE EN GARDE

LE SOUDAGE A L'ARC EST DANGEREUX

PROTEGEZ-VOUS, AINSI QUE LES AUTRES, CONTRE LES BLESSURES GRAVES POSSIBLES OU LA MORT. NE LAISSEZ PAS LES ENFANTS S'APPROCHER, NI LES PORTEURS DE STIMULATEUR CARDIAQUE (A MOINS QU'ILS N'AIENT CONSULTÉ UN MÉDECIN). CONSERVEZ CES INSTRUCTIONS. LISEZ LE MANUEL D'OPERATION OU LES INSTRUCTIONS AVANT D'INSTALLER, UTILISER OU ENTREtenir CET EQUIPEMENT.

Les produits et procédés de soudage peuvent sauser des blessures graves ou la mort, de même que des dommages au reste du matériel et à la propriété, si l'utilisateur n'adhère pas strictement à toutes les règles de sécurité et ne prend pas les précautions nécessaires.

En soudage et coupage, des pratiques sécuritaires se sont développées suite à l'expérience passée. Ces pratiques doivent être apprises par étude ou entraînement avant d'utiliser l'équipement. Toute personne n'ayant pas suivi un entraînement intensif en soudage et coupage ne devrait pas tenter de souder. Certaines pratiques concernent les équipements raccordés aux lignes d'alimentation alors que d'autres s'adressent aux groupes électrogènes.

La norme Z49.1 de l'American National Standard, intitulée "SAFETY IN WELDING AND CUTTING" présente les pratiques sécuritaires à suivre. Ce document ainsi que d'autres guides que vous devriez connaître avant d'utiliser cet équipement sont présentés à la fin de ces instructions de sécurité.

SEULES DES PERSONNES QUALIFIEES DOIVENT FAIRE DES TRAVAUX D'INSTALLATION, DE REPARATION, D'ENTRETIEN ET D'ESSAI.

1.04 Dangers Relatifs au Soudage à l'Arc



AVERTISSEMENT

L'ELECTROCUTION PEUT ETRE MORTELLE.

Une décharge électrique peut tuer ou brûler gravement. L'électrode et le circuit de soudage sont sous tension dès la mise en circuit. Le circuit d'alimentation et les circuits internes de l'équipement sont aussi sous tension dès la mise en marche. En soudage automatique ou semi-automatique avec fil, ce dernier, le rouleau ou la bobine de fil, le logement des galets d'entraînement et toutes les pièces métalliques en contact avec le fil de soudage sont sous tension. Un équipement inadéquatement installé ou inadéquatement mis à la terre est dangereux.

1. Ne touchez pas à des pièces sous tension.
2. Portez des gants et des vêtements isolants, secs et non troués.
3. Isolez-vous de la pièce à souder et de la mise à la terre au moyen de tapis isolants ou autres.
4. Déconnectez la prise d'alimentation de l'équipement ou arrêtez le moteur avant de l'installer ou d'en faire l'entretien. Bloquez le commutateur en circuit ouvert ou enlevez les fusibles de l'alimentation afin d'éviter une mise en marche accidentelle.
5. Veuillez à installer cet équipement et à le mettre à la terre selon le manuel d'utilisation et les codes nationaux, provinciaux et locaux applicables.
6. Arrêtez tout équipement après usage. Coupez l'alimentation de l'équipement s'il est hors d'usage ou inutilisé.
7. N'utilisez que des porte-électrodes bien isolés. Ne jamais plonger les porte-électrodes dans l'eau pour les refroidir. Ne jamais les laisser traîner par terre ou sur les pièces à souder. Ne touchez pas aux porte-électrodes raccordés à deux sources de courant en même temps. Ne jamais toucher quelqu'un d'autre avec l'électrode ou le porte-électrode.
8. N'utilisez pas de câbles électriques usés, endommagés, mal épissés ou de section trop petite.
9. N'enroulez pas de câbles électriques autour de votre corps.
10. N'utilisez qu'une bonne prise de masse pour la mise à la terre de la pièce à souder.
11. Ne touchez pas à l'électrode lorsqu'en contact avec le circuit de soudage (terre).
12. N'utilisez que des équipements en bon état. Réparez ou remplacez aussitôt les pièces endommagées.
13. Dans des espaces confinés ou mouillés, n'utilisez pas de source de courant alternatif, à moins qu'il soit muni d'un réducteur de tension. Utilisez plutôt une source de courant continu.
14. Portez un harnais de sécurité si vous travaillez en hauteur.
15. Fermez solidement tous les panneaux et les capots.



AVERTISSEMENT

LE RAYONNEMENT DE L'ARC PEUT BRÛLER LES YEUX ET LA PEAU; LE BRUIT PEUT ENDOMMAGER L'OUÏE.

L'arc de soudage produit une chaleur et des rayons ultraviolets intenses, susceptibles de brûler les yeux et la peau. Le bruit causé par certains procédés peut endommager l'ouïe.

1. Portez une casque de soudeur avec filtre oculaire de nuance appropriée (consultez la norme ANSI Z49 indiquée ci-après) pour vous protéger le visage et les yeux lorsque vous soudez ou que vous observez l'exécution d'une soudure.
2. Portez des lunettes de sécurité approuvées. Des écrans latéraux sont recommandés.
3. Entourez l'aire de soudage de rideaux ou de cloisons pour protéger les autres des coups d'arc ou de l'éblouissement; avertissez les observateurs de ne pas regarder l'arc.
4. Portez des vêtements en matériaux ignifuges et durables (laine et cuir) et des chaussures de sécurité.
5. Portez un casque antibruit ou des bouchons d'oreille approuvés lorsque le niveau de bruit est élevé.



AVERTISSEMENT

LES VAPEURS ET LES FUMÉES SONT DANGEREUSES POUR LA SANTÉ.

Le soudage dégage des vapeurs et des fumées dangereuses à respirer.

1. Eloignez la tête des fumées pour éviter de les respirer.
2. A l'intérieur, assurez-vous que l'aire de soudage est bien ventilée ou que les fumées et les vapeurs sont aspirées à l'arc.
3. Si la ventilation est inadéquate, portez un respirateur à adduction d'air approuvé.
4. Lisez les fiches signalétiques et les consignes du fabricant relatives aux métaux, aux produits consommables, aux revêtements et aux produits nettoyants.
5. Ne travaillez dans un espace confiné que s'il est bien ventilé; sinon, portez un respirateur à adduction d'air. Les gaz protecteurs de soudage peuvent déplacer l'oxygène de l'air et ainsi causer des malaises ou la mort. Assurez-vous que l'air est propre à la respiration.
6. Ne soudez pas à proximité d'opérations de dégraissage, de nettoyage ou de pulvérisation. La chaleur et les rayons de l'arc peuvent réagir avec des vapeurs et former des gaz hautement toxiques et irritants.

SELECTION DES NUANCES DE FILTRES OCULAIRES POUR LA PROTECTION DES YEUX EN COUPAGE ET SOUDAGE (selon AWS à 8.2-73)

Opération de coupage ou soudage	Dimension d'électrode ou Epiasseur de métal ou Intensité de courant	Nuance de filtre oculaire	Opération de coupage ou soudage	Dimension d'électrode ou Epiasseur de métal ou Intensité de courant	Nuance de filtre oculaire
Brassage tendre au chalumeau	toutes conditions	2	Soudage à l'arc sous gaz avec fil plein (GMAW)		
Brassage fort au chalumeau	toutes conditions	3 ou 4	métaux non-ferreux	toutes conditions	11
Oxycoupage			métaux ferreux	toutes conditions	12
mince	moins de 1 po. (25 mm)	2 ou 3	Soudage à l'arc sous gaz avec électrode de tungstène (GTAW)	toutes conditions	12
moyen	de 1 à 6 po. (25 à 150 mm)	4 ou 5	Soudage à l'hydrogène atomique (AHW)	toutes conditions	12
épais	plus de 6 po. (150 mm)	5 ou 6	Soudage à l'arc avec électrode de carbone (CAW)	toutes conditions	12
Soudage aux gaz			Soudage à l'arc Plasma (PAW)	toutes dimensions	12
mince	moins de 1/8 po. (3 mm)	4 ou 5	Gougeage Air-Arc avec électrode de carbone		
moyen	de 1/8 à 1/2 po. (3 à 12 mm)	5 ou 6	mince		12
épais	plus de 1/2 po. (12 mm)	6 ou 8	épais		14
Soudage à l'arc avec électrode enrobées (SMAW)	moins de 5/32 po. (4 mm)	10	Coupage à l'arc Plasma (PAC)		
	5/32 à 1/4 po. (4 à 6.4 mm)	12	mince	moins de 300 ampères	9
	plus de 1/4 po. (6.4 mm)	14	moyen	de 300 à 400 ampères	12
			épais	plus de 400 ampères	14

- Ne soudez des tôles galvanisées ou plaquées au plomb ou au cadmium que si les zones à souder ont été grattées à fond, que si l'espace est bien ventilé; si nécessaire portez un respirateur à induction d'air. Car ces revêtements et tout métal qui contient ces éléments peuvent dégager des fumées toxiques au moment du soudage.



AVERTISSEMENT

LE SOUDAGE PEUT CAUSER UN INCENDIE OU UNE EXPLOSION

L'arc produit des étincelles et des projections. Les particules volantes, le métal chaud, les projections de soudure et l'équipement surchauffé peuvent causer un incendie et des brûlures. Le contact accidentel de l'électrode ou du fil-électrode avec un objet métallique peut provoquer des étincelles, un échauffement ou un incendie.

- Protégez-vous, ainsi que les autres, contre les étincelles et du métal chaud.
- Ne soudez pas dans un endroit où des particules volantes ou des projections peuvent atteindre des matériaux inflammables.
- Enlevez toutes matières inflammables dans un rayon de 10, 7 mètres autour de l'arc, ou couvrez-les soigneusement avec des bâches approuvées.
- Méfiez-vous des projections brûlantes de soudage susceptibles de pénétrer dans des aires adjacentes par de petites ouvertures ou fissures.
- Méfiez-vous des incendies et gardez un extincteur à portée de la main.
- N'oubliez pas qu'une soudure réalisée sur un plafond, un plancher, une cloison ou une paroi peut enflammer l'autre côté.
- Ne soudez pas un récipient fermé, tel un réservoir ou un baril.
- Connectez le câble de soudage le plus près possible de la zone de soudage pour empêcher le courant de suivre un long parcours inconnu, et prévenir ainsi les risques d'électrocution et d'incendie.
- Ne dégelez pas les tuyaux avec un source de courant.
- Otez l'électrode du porte-électrode ou coupez le fil au tube-contact lorsqu'inutilisé après le soudage.
- Portez des vêtements protecteurs non huileux, tels des gants en cuir, une chemise épaisse, un pantalon revers, des bottines de sécurité et un casque.



AVERTISSEMENT

LES ETINCELLES ET LES PROJECTIONS BRULANTES PEUVENT CAUSER DES BLESSURES.

Le piquage et le meulage produisent des particules métalliques volantes. En refroidissant, la soudure peut projeter du éclats de laitier.

- Portez un écran facial ou des lunettes protectrices approuvées. Des écrans latéraux sont recommandés.
- Portez des vêtements appropriés pour protéger la peau.



AVERTISSEMENT

LES BOUTEILLES ENDOMMAGEES PEUVENT EXPLOSER

Les bouteilles contiennent des gaz protecteurs sous haute pression. Des bouteilles endommagées peuvent exploser. Comme les bouteilles font normalement partie du procédé de soudage, traitez-les avec soin.

- Protégez les bouteilles de gaz comprimé contre les sources de chaleur intense, les chocs et les arcs de soudage.
- Enchainez verticalement les bouteilles à un support ou à un cadre fixe pour les empêcher de tomber ou d'être renversées.
- Eloignez les bouteilles de tout circuit électrique ou de tout soudage.
- Empêchez tout contact entre une bouteille et une électrode de soudage.
- N'utilisez que des bouteilles de gaz protecteur, des détendeurs, des boyaux et des raccords conçus pour chaque application spécifique; ces équipements et les pièces connexes doivent être maintenus en bon état.
- Ne placez pas le visage face à l'ouverture du robinet de la bouteille lors de son ouverture.
- Laissez en place le chapeau de bouteille sauf si en utilisation ou lorsque raccordé pour utilisation.
- Lisez et respectez les consignes relatives aux bouteilles de gaz comprimé et aux équipements connexes, ainsi que la publication P-1 de la CGA, identifiée dans la liste de documents ci-dessous.



AVERTISSEMENT

LES MOTEURS PEUVENT ETRE DANGEREUX

LES GAZ D'ECHAPPEMENT DES MOTEURS PEUVENT ETRE MORTELS.

Les moteurs produisent des gaz d'échappement nocifs.

ARCMaster 400 TS

1. Utilisez l'équipement à l'extérieur dans des aires ouvertes et bien ventilées.
2. Si vous utilisez ces équipements dans un endroit confiné, les fumées d'échappement doivent être envoyées à l'extérieur, loin des prises d'air du bâtiment.



AVERTISSEMENT

LE CARBURANT PEUT CAUSER UN INCENDIE OU UNE EXPLOSION.

Le carburant est hautement inflammable.

1. Arrêtez le moteur avant de vérifier le niveau de carburant ou de faire le plein.
2. Ne faites pas le plein en fumant ou proche d'une source d'étincelles ou d'une flamme nue.
3. Si c'est possible, laissez le moteur refroidir avant de faire le plein de carburant ou d'en vérifier le niveau au début du soudage.
4. Ne faites pas le plein de carburant à ras bord: prévoyez de l'espace pour son expansion.
5. Faites attention de ne pas renverser de carburant. Nettoyez tout carburant renversé avant de faire démarrer le moteur.



AVERTISSEMENT

DES PIÈCES EN MOUVEMENT PEUVENT CAUSER DES BLESSURES.

Des pièces en mouvement, tels des ventilateurs, des rotors et des courroies peuvent couper doigts et mains, ou accrocher des vêtements amples.

1. Assurez-vous que les portes, les panneaux, les capots et les protecteurs soient bien fermés.
2. Avant d'installer ou de connecter un système, arrêtez le moteur.
3. Seules des personnes qualifiées doivent démonter des protecteurs ou des capots pour faire l'entretien ou le dépannage nécessaire.
4. Pour empêcher un démarrage accidentel pendant l'entretien, débranchez le câble d'accumulateur à la borne négative.
5. N'approchez pas les mains ou les cheveux de pièces en mouvement; elles peuvent aussi accrocher des vêtements amples et des outils.
6. Réinstallez les capots ou les protecteurs et fermez les portes après des travaux d'entretien et avant de faire démarrer le moteur.



AVERTISSEMENT

DES ÉTINCELLES PEUVENT FAIRE EXPLOSER UN ACCUMULATEUR; L'ÉLECTROLYTE D'UN ACCUMULATEUR PEUT BRÛLER LA PEAU ET LES YEUX.

Les accumulateurs contiennent de l'électrolyte acide et dégagent des vapeurs explosives.

1. Portez toujours un écran facial en travaillant sur un accumulateur.
2. Arrêtez le moteur avant de connecter ou de déconnecter des câbles d'accumulateur.
3. N'utilisez que des outils anti-étincelles pour travailler sur un accumulateur.
4. N'utilisez pas une source de courant de soudage pour charger un accumulateur ou survolter momentanément un véhicule.
5. Utilisez la polarité correcte (+ et -) de l'accumulateur.



AVERTISSEMENT

LA VAPEUR ET LE LIQUIDE DE REFROIDISSEMENT BRÛLANT SOUS PRESSION PEUVENT BRÛLER LA PEAU ET LES YEUX.

Le liquide de refroidissement d'un radiateur peut être brûlant et sous pression.

1. N'ôtez pas le bouchon de radiateur tant que le moteur n'est pas refroidi.
2. Mettez des gants et posez un torchon sur le bouchon pour l'ôter.
3. Laissez la pression s'échapper avant d'ôter complètement le bouchon.

1.05 Principales Normes de Sécurité

Safety in Welding and Cutting, norme ANSI Z49.1, American Welding Society, 550 N.W. LeJeune Rd., Miami, FL 33128.

Safety and Health Standards, OSHA 29 CFR 1910, Superintendent of Documents, U.S. Government Printing Office, Washington, D.C. 20402.

Recommended Safe Practices for the Preparation for Welding and Cutting of Containers That Have Held Hazardous Substances, norme AWS F4.1, American Welding Society, 550 N.W. LeJeune Rd., Miami, FL 33128.

National Electrical Code, norme 70 NFPA, National Fire Protection Association, Batterymarch Park, Quincy, MA 02269.

Safe Handling of Compressed Gases in Cylinders, document P-1, Compressed Gas Association, 1235 Jefferson Davis Highway, Suite 501, Arlington, VA 22202.

Code for Safety in Welding and Cutting, norme CSA W117.2 Association canadienne de normalisation, Standards Sales, 276 Rexdale Boulevard, Rexdale, Ontario, Canada M9W 1R3.

Safe Practices for Occupation and Educational Eye and Face Protection, norme ANSI Z87.1, American National Standards Institute, 1430 Broadway, New York, NY 10018.

Cutting and Welding Processes, norme 51B NFPA, National Fire Protection Association, Batterymarch Park, Quincy, MA 02269.

1.06 Declaration Of Conformity



Manufacturer: Victor Technologies
Address: 82 Benning Street
West Lebanon, New Hampshire 03784
USA

The equipment described in this manual conforms to all applicable aspects and regulations of the 'Low Voltage Directive' (2006/95 EC) and to the National legislation for the enforcement of this Directive.

The equipment described in this manual conforms to all applicable aspects and regulations of the "EMC Directive" (European Council Directive 2004/108/EC) and to the National legislation for the enforcement of this Directive.

Serial numbers are unique with each individual piece of equipment and details description, parts used to manufacture a unit and date of manufacture.

National Standard and Technical Specifications

The product is designed and manufactured to a number of standards and technical requirements. Among them are:









- CSA (Canadian Standards Association) standard C22.2 number 60 for Arc welding equipment.
- UL (Underwriters Laboratory) rating 94VO flammability testing for all printed-circuit boards used.
- CENELEC EN50199 EMC Product Standard for Arc Welding Equipment.
- ISO/IEC 60974-1 (BS 638-PT10) (EN 60 974-1) (EN50192) (EN50078) applicable to plasma cutting equipment and associated accessories.
- For environments with increased hazard of electrical shock, Power Supplies bearing the S mark conform to EN50192 when used in conjunction with hand torches with exposed cutting tips, if equipped with properly installed standoff guides.
- Extensive product design verification is conducted at the manufacturing facility as part of the routine design and manufacturing process. This is to ensure the product is safe, when used according to instructions in this manual and related industry standards, and performs as specified. Rigorous testing is incorporated into the manufacturing process to ensure the manufactured product meets or exceeds all design specifications.













Victor Technologies has been manufacturing products for more than 30 years, and will continue to achieve excellence in our area of manufacture.

Manufacturers responsible representative:

Steve Ward
Operations Director
Victor Technologies Europe
Europa Building
Chorley N Industrial Park
Chorley, Lancashire,
England PR6 7BX

SYMBOL LEGEND

A	Amperage
V	Voltage
Hz	Hertz (frequency)
SEC	Seconds
%	Percent
	DC (Direct Current)
	AC (Alternating Current)
	Standard Function
	Slope Function
	Slope W/Repeat Function
	Spot Function
	Impulse Starting (High Frequency GTAW)
	Touch Start (Lift Start TIG circuit GTAW)

	STICK (Shielded Metal Arc SMAW)
	Pulse Current Function
	Spot Time (GTAW)
	Remote Control (Panel/Remote)
	Remote Function
	Arc Control (SMAW)
	Gas Post-Flow
	Gas Pre-Flow
VRD	Voltage Reduction Device Circuit
	Negative
	Positive
	Gas Input
	Gas Output

SECTION 2: INTRODUCTION AND DESCRIPTION

2.01 How To Use This Manual

This Owner's Manual applies to part number 10-3091.

To ensure safe operation, read the entire manual, including the chapter on safety instructions and warnings.

Throughout this manual, the words **WARNING**, **CAUTION**, and **NOTE** may appear. Pay particular attention to the information provided under these headings. These special annotations are easily recognized as follows:



WARNING

A WARNING gives information regarding possible personal injury.

CAUTION

A CAUTION refers to possible equipment damage.

NOTE

A NOTE offers helpful information concerning certain operating procedures.

Additional copies of this manual may be purchased by contacting Thermal Arc at the address and phone number given in the next section. Include the Owner's Manual number and equipment identification numbers.

Electronic copies of this manual can also be downloaded at no charge in Acrobat PDF format by going to the Thermal Arc web site listed below and clicking on the Literature Library link:

<http://www.thermalarc.com>

2.02 Equipment Identification

The unit's identification number (specification or part number), model, and serial number usually appear on a nameplate attached to the control panel. In some cases, the nameplate may be attached to the rear panel. Equipment which does not have a control panel such as gun and cable assemblies is identified only by the part number printed on the shipping container. Record this number for future reference.

2.03 Receipt of Equipment

When you receive the equipment, check it against the invoice to make sure it is complete and inspect the equipment for possible damage due to shipping. If there is any damage, notify the carrier immediately to file a claim. Furnish complete information concerning damage claims or shipping errors to the location in your area listed in the inside back cover of this manual.

Include all equipment identification numbers as described above along with a full description of the parts in error.

Move the equipment to the installation site before uncrating the unit. Use care to avoid damaging the equipment when using bars, hammers, etc., to uncrate the unit.

2.04 Description

The Thermal Arc™ ArcMaster 400 TS is a single/three-phase DC arc welding power source with Constant Current (CC) output characteristics. This unit is equipped with a Digital Volt/Amperage Meter, gas control valve, built in Sloper and Pulser, lift arc starter, and high-frequency arc starter for use with Gas Tungsten Arc Welding (GTAW), Gas Tungsten Arc Welding-Pulse (GTAW-P), Gas Tungsten Arc Welding-Sloped (GTSW-S), and Shielded Metal Arc Welding (SMAW) processes. The power source is totally enclosed in an impact resistant, flame resistant and non-conductive plastic case.

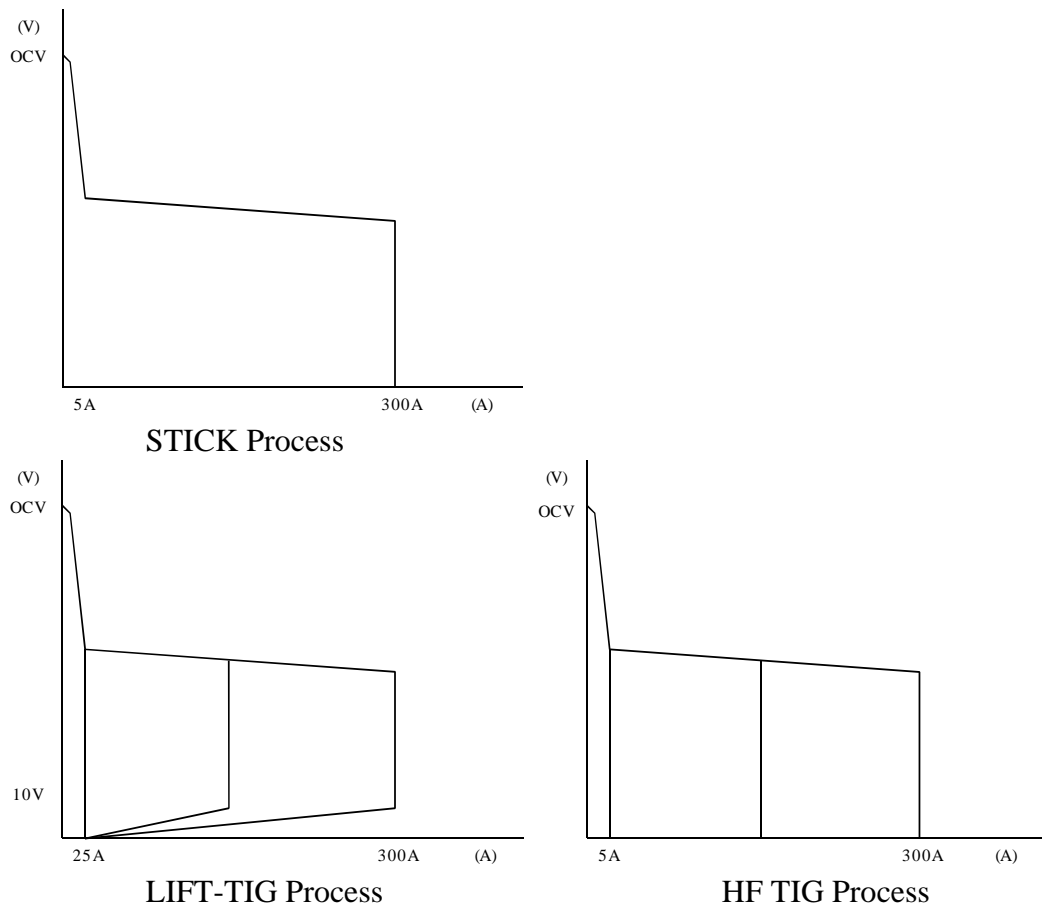


Figure 1. Model 400 TS Volt-Ampere Curve

Note 1

Volt-Ampere curves show the maximum Voltage and Amperage output capabilities of the welding power source. Curves of other settings will fall between the curves shown.

2.05 Functional Block Diagram

Figure 2 illustrates the functional block diagram of the 400 TS power supply.

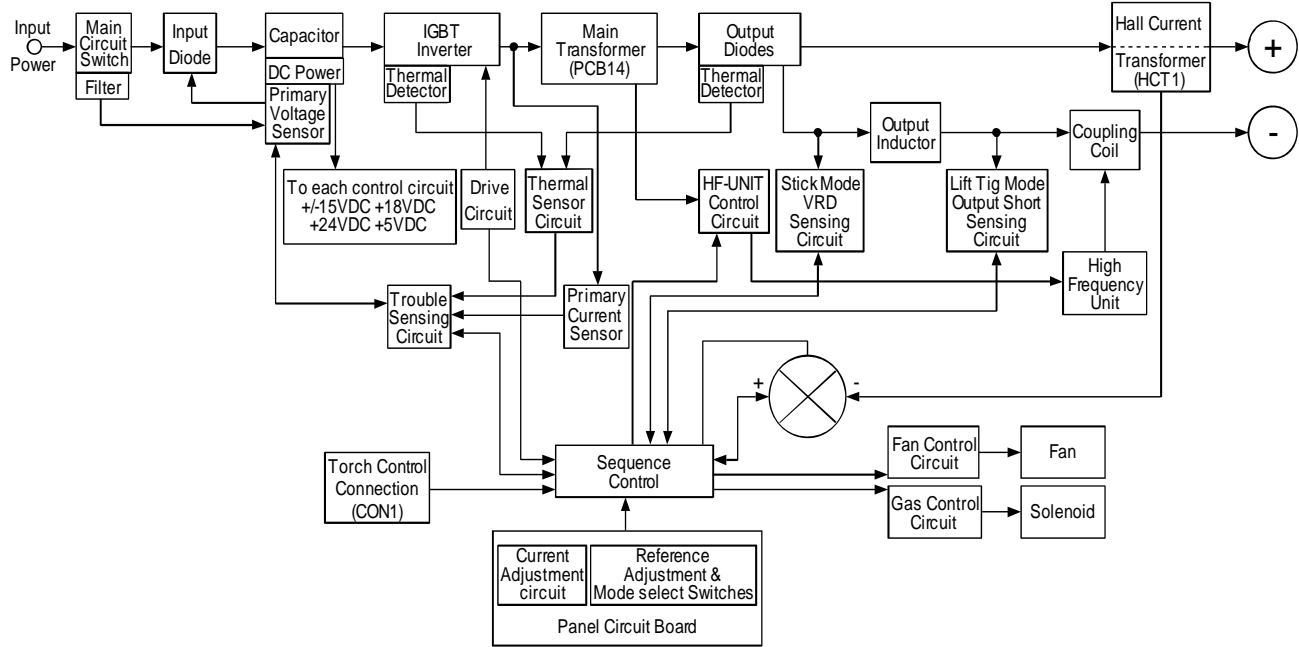


Figure 2. 400 TS Model Functional Block Diagram

2.06 Transporting Methods

This unit is equipped with a handle for carrying purposes.



WARNING 1

ELECTRIC SHOCK can kill. DO NOT TOUCH live electrical parts. Disconnect input power conductors from de-energized supply line before moving the welding power source.



WARNING 2

FALLING EQUIPMENT can cause serious personal injury and equipment damage.

Lift unit with handle on top of case.

Use handcart or similar device of adequate capacity.

If using a fork lift vehicle, place and secure unit on a proper skid before transporting.

SECTION 3: INSTALLATION RECOMMENDATIONS

3.01 Environment

The ArcMaster 400 TS is designed for use in hazardous environments.

Examples of environments with increased hazardous environments are:

- a. In locations in which freedom of movement is restricted, so that the operator is forced to perform the work in a cramped (kneeling, sitting or lying) position with physical contact with conductive parts.
- b. In locations which are fully or partially limited by conductive elements, and in which there is a high risk of unavoidable or accidental contact by the operator.
- c. In wet or damp hot locations where humidity or perspiration considerably reduces the skin resistance of the human body and the insulation properties of accessories.

Environments with hazardous environments do not include places where electrically conductive parts in the near vicinity of the operator, which can cause increased hazard, have been insulated.

3.02 Location

Be sure to locate the welder according to the following guidelines:

- *In areas, free from moisture and dust.*
- *Ambient temperature between 0 degrees C to 40 degrees C.*
- *In areas, free from oil, steam and corrosive gases.*
- *In areas, not subjected to abnormal vibration or shock.*
- *In areas, not exposed to direct sunlight or rain.*
- *Place at a distance of 12" (304.79mm) or more from walls or similar boundaries that could restrict natural airflow for cooling.*



WARNING 3

Thermal Arc advises that this equipment be electrically connected by a qualified electrician.

3.03 Electrical Input Connections



WARNING 4

ELECTRIC SHOCK can kill; SIGNIFICANT DC VOLTAGE is present after removal of input power.

SHUT DOWN welding power source, disconnect input power employing lockout/tagging procedures. Lockout/tagging procedures consist of padlocking line disconnect switch in open position, removing fuses from fuse box, or shutting OFF and red-tagging circuit breaker or other disconnecting device.

1. Connect end of ground (YELLOW/GREEN) conductor to a suitable ground. Use a grounding method that complies with all applicable electrical codes.
2. Connect ends of line 1 (BROWN) and line 2 (BLUE) and line 3 (RED) input conductors to a de-energized line disconnect switch.
3. Use Table 1 and Table 2 as a guide to select line fuses for the disconnect switch.

Input Voltage	Fuse Size
400 VAC	60 Amps

Table 1 - Electrical Input Connections

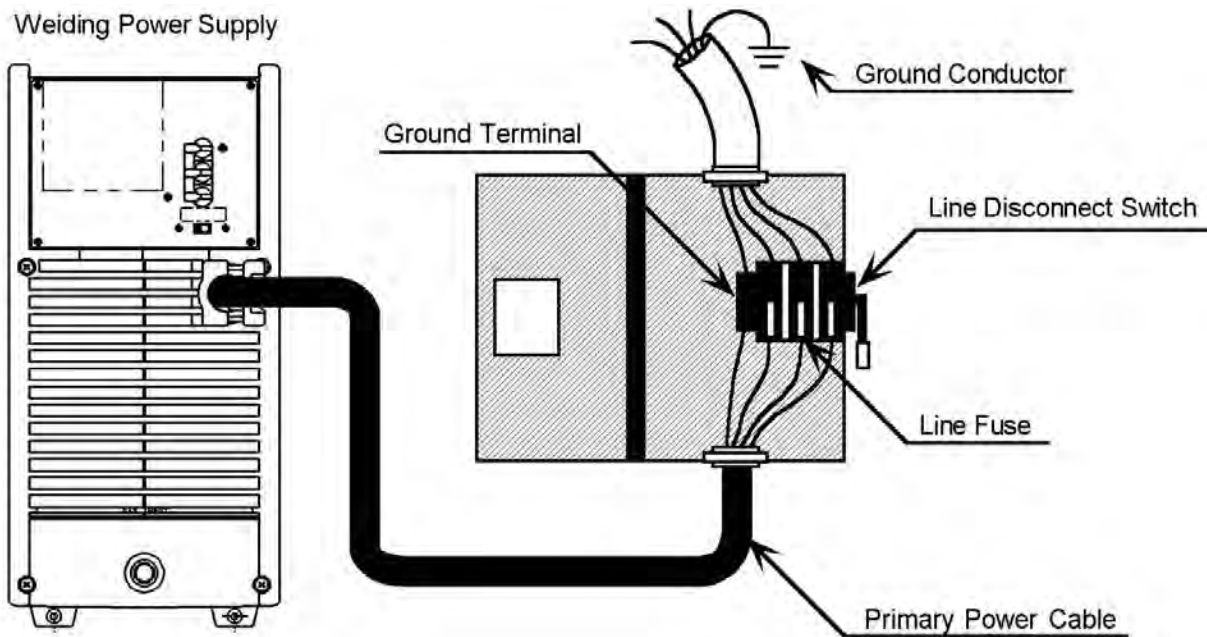


Figure 3 - Electrical Input Connections

3.03.02 Input Power

Each unit incorporates an INRUSH circuit and input voltage sensing circuit. When the MAIN INPUT SWITCH is turned ON, the inrush circuit provides a pre-charging of the input capacitors. SCR's in the Power Control Assembly (PCA) will turn ON after the input capacitors have charged to full operating voltage (after approximately 5 seconds).

Note 3

Note the available input power. Damage to the PCA could occur if 460VAC or higher is applied.

The following Primary Current recommendations are required to obtain the maximum welding current and duty cycle from this welding equipment:

Model	Primary Supply Lead Size (Factory Fitted)	Minimum Primary Current Circuit Size (Vin/Amps)	Current & Duty Cycle	
			TIG	STICK
ArcMaster 400 TS	4mm sq / 4 minimum	400/25	400 @ 25%	-
		400/35	-	400 @ 25%

Table 2. 400V Primary Current Circuit sizes to achieve maximum current

3.03.03 High Frequency Introduction

The importance of correct installation of high frequency welding equipment cannot be over-emphasized. Interference due to high frequency initiated or stabilized arc is almost invariably traced to improper installation. The following information is intended as a guide for personnel installing high frequency welding machines.

Warning

Explosives

The high frequency section of this machine has an output similar to a radio transmitter. The machine should NOT be used in the vicinity of blasting operations due to the danger of premature firing.

Computers

It is also possible that operation close to computer installations may cause computer malfunction.

3.03.04 High Frequency Interference

Interference may be transmitted by a high frequency initiated or stabilized arc welding machine in the following ways:

Direct Radiation

Radiation from the machine can occur if the case is metal and is not properly grounded. It can occur through apertures such as open access panels. The shielding of the high frequency unit in the Power Source will prevent direct radiation if the equipment is properly grounded.

Transmission via the Supply Lead

Without adequate shielding and filtering, high frequency energy may be fed to the wiring within the installation (mains) by direct coupling. The energy is then transmitted by both radiation and conduction. Adequate shielding and filtering is provided in the Power Source.

Radiation from Welding Leads

Radiated interference from welding leads, although pronounced in the vicinity of the leads, diminishes rapidly with distance. Keeping leads as short as possible will minimize this type of interference. Looping and suspending of leads should be avoided where possible.

Re-radiation from Unearthed Metallic Objects

A major factor contributing to interference is re-radiation from unearthed metallic objects close to the welding leads. Effective grounding of such objects will prevent re-radiation in most cases.

3.04 Specifications

Parameter	400 TS	
Rated Output	400VAC	
Amperes	300	
Volts	36	
Duty Cycle	25%	
Duty Cycle	400A / 36V @ 25% (3ph) 300A / 32V @ 60% (3ph) 200A / 28V @ 100% (1ph)	
Output Current Range	5 – 400 Amps	
Open Circuit Voltage	57V	
Dimensions		
Width	8.3" (210mm)	
Height	16.5" (420mm)	
Length	17.7" (450mm)	
Weight	52.9 lb. 24 kg	
Output @ Rated Load	Three-phase	
Output Amperes	400A	
Output Volts	36V	
Duty Cycle	25%	
KVA	24.0	
KW	18.0	
Output @ No Load		
KVA	0.5	
KW	0.13	
Input Volts Three Phase	Amperage Draw @ Rated Load	No Load
400V	31	0.7

Thermal Arc continuously strives to produce the best product possible and therefore reserves the right to change, improve or revise the specifications or design of this or any product without prior notice. Such updates or changes do not entitle the buyer of equipment previously sold or shipped to the corresponding changes, updates, improvements or replacement of such items.

3.05 Duty Cycle

The duty cycle of a welding power source is the percentage of a ten (10) minute period that it can be operated at a given output without causing overheating and damage to the unit. If the welding amperes decrease, the duty cycle increases. If the welding amperes are increased beyond the rated output, the duty cycle will decrease.



WARNING 5

Exceeding the duty cycle ratings will cause the thermal overload protection circuit to become energized and shut down the output until the unit has cooled to normal operating temperature.

CAUTION 1

Continually exceeding the duty cycle ratings can cause damage to the welding power source and will void the manufactures warranty.

NOTE 4

Due to variations that can occur in manufactured products, claimed performance, voltages, ratings, all capacities, measurements, dimensions and weights quoted are approximate only. Achievable capacities and ratings in use and operation will depend upon correct installation, use, applications, maintenance and service.

SECTION 4: OPERATOR CONTROLS

4.01 ARC MASTER 400 TS Controls

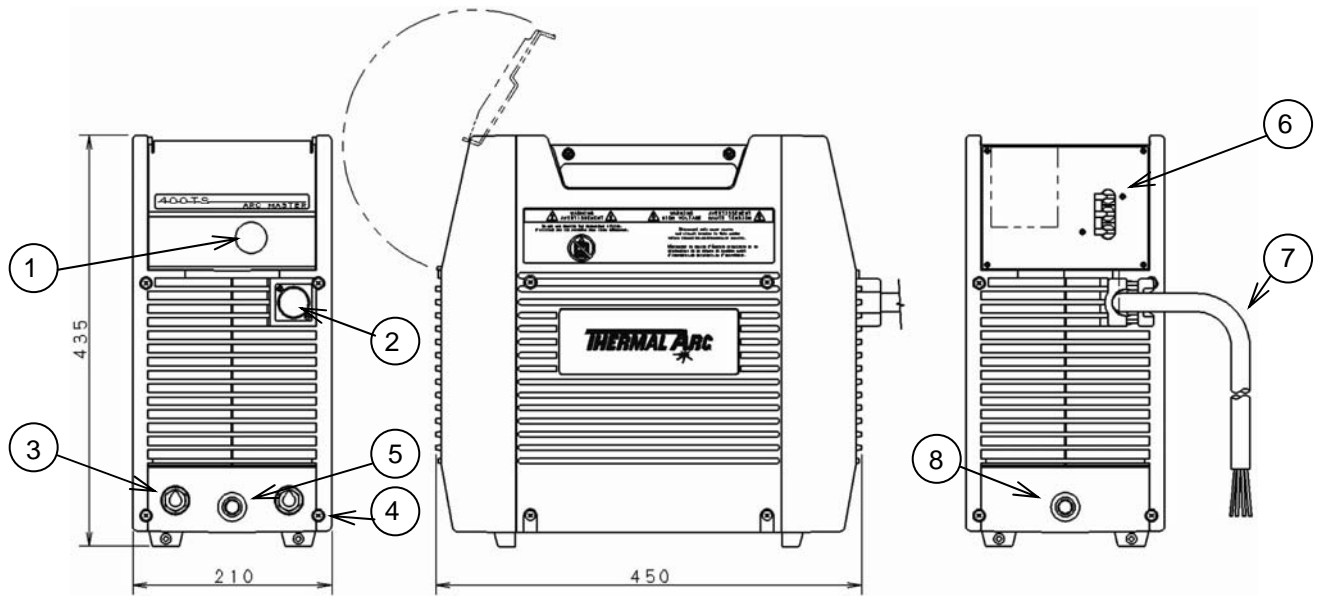


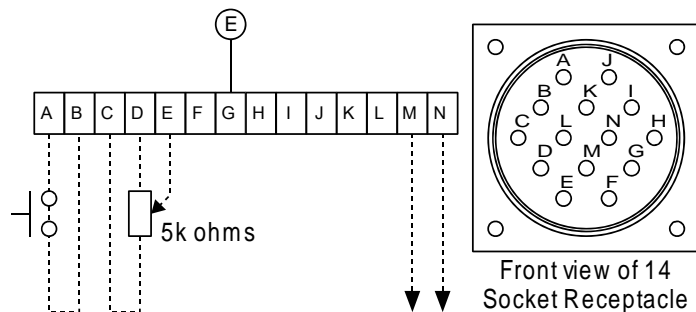
Figure 4. ARC MASTER 400 TS Power Source

1 Control Knob

This control sets the selected weld parameter, rotating it clockwise increases the parameter that is indicated on the digital meter. Pushing the knob inward displays the actual welding voltage.

2 Remote Control Socket

The 14 pin Remote Control Socket is used to connect remote current control devices to the welding Power Source. To make connections, align keyway, insert plug, and rotate threaded collar fully clockwise.



Socket Pin	Function
A	Torch Switch Input (24V) to energize weld current. (connect pins A & B to turn ON welding current)
B	Torch Switch Input (0V) to energize weld current (connect pins A & B to turn ON welding current)
C	5k ohm (maximum) connection to 5k ohm remote control potentiometer
D	Zero ohm (minimum) connection to 5k ohm remote control potentiometer
E	Wiper arm connection to 5k ohm remote control potentiometer
G	Mains Earth
F,H,I,J,K,L	Not Used
M	OK to move current detect signal for robotics applications
N	OK to move current detect signal for robotics applications

3 Positive Terminal

Welding current flows from the Power Source via heavy duty Dinse type terminal. It is essential, however, that the male plug is inserted and turned securely to achieve a sound electrical connection.

4 Negative Terminal

Welding current flows from the Power Source via heavy duty Dinse type terminal. It is essential, however, that the male plug is inserted and turned securely to achieve a sound electrical connection.

CAUTION 2

Loose welding terminal connections can cause overheating and result in the male plug being fused in the bayonet terminal.

5 Gas

The Gas Outlet is a BSP - 3/8 inch female gas fitting.

6 ON/OFF Switch

This switch connects the Primary supply voltage to the inverter when in the ON position. This enables the Power Supply.



WARNING 6

When the welder is connected to the Primary supply voltage, the internal electrical components maybe at primary potential with respect to earth.

7 Input Cable

The input cable connects the Primary supply voltage to the equipment.

8 Gas Inlet

The Gas Inlet is a BSP - 3/8 inch female gas fitting.

4.02 Weld Process Selection for ArcMaster 400 TS


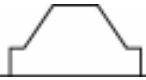



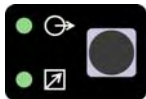
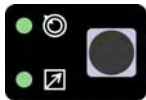
Weld Process Selection	Weld Mode			Description
	STICK	HF TIG	LIFT TIG	
 <i>STD</i>	Yes	Yes	Yes	2T operation in TIG Modes using remote devices to control contactor & current.
 <i>SLOPE</i>	No	Yes	Yes	4T operation in TIG Modes with crater fill using a remote contactor device to control sequence.
 <i>REPEAT</i>	No	Yes	Yes	4T operation in TIG Modes with repeat operation and crater fill using a remote contactor device.
 <i>SPOT</i>	No	Yes	No	2T operation spot welding in HF TIG using a remote contactor device.
 <i>PULSE ON/OFF</i>	No	Yes	Yes	Pulse operation in TIG Modes.
 <i>Contactor ON/OFF</i>	Yes	No	Yes	Contactor operation in Stick and Lift TIG Mode.
 <i>Operation PANEL/REMOTE</i>	Yes	Yes	Yes	Selects in Operation Panel Board or Remote.

Table 3 – Weld Process Selection verses Weld Mode for ArcMaster 400 TS

4.03 Weld Parameter Description

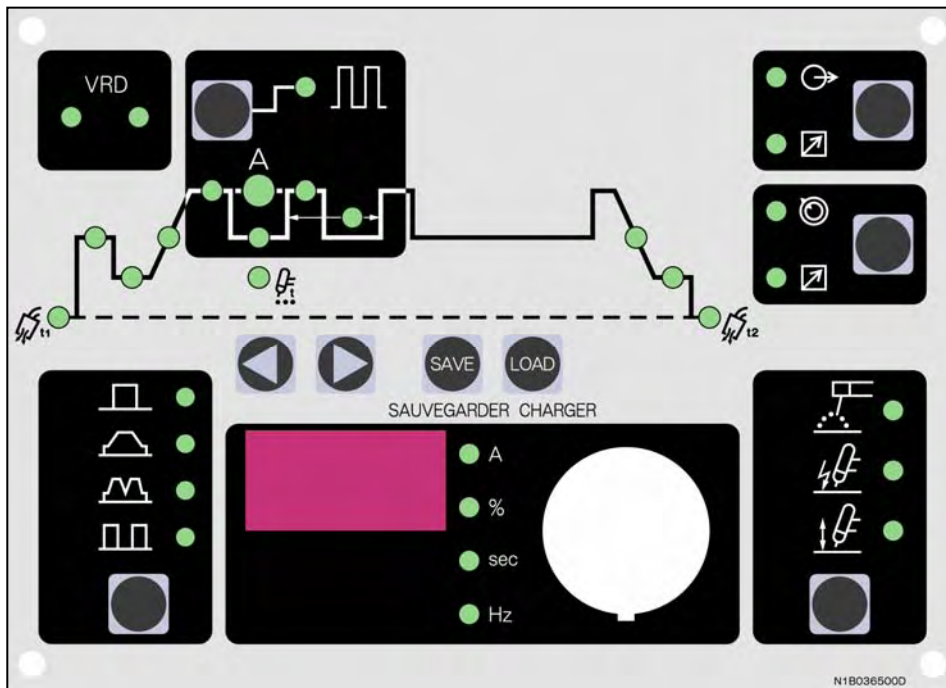



Figure 5. ArcMaster 400 TS Front Panel with Parameter Description

Parameter	Description
 PRE-FLOW	<p>This parameter operates in TIG modes only and is used to get gas to the weld zone prior to striking the arc, once the torch trigger switch has been pressed. This control is used to dramatically reduce weld porosity at the start of a weld.</p>
HOT START	<p>This parameter operates in all weld modes except Lift TIG mode and is used to heat up the weld zone in TIG modes or improve the start characteristics for stick electrodes. e.g. low hydrogen electrodes. It sets the peak start current on top of the <i>PEAK (WELD)</i> current.</p> <p>e.g. <i>HOT START</i> current = 130 amps when <i>PEAK (WELD)</i> = 100 amps & <i>HOT START</i> = 30 amps</p>
INITIAL CUR.	<p>This parameter operates in <i>SLOPE</i> or <i>REPEAT(4T)</i> TIG modes only and is used to set the start current for TIG. The Start Current remains ON until the torch trigger switch is released after it has been depressed.</p>
UP SLOPE	<p>This parameter operates in TIG modes only and is used to set the time for the weld current to ramp up, after the torch trigger switch has been pressed then released, from <i>INITIAL CUR</i> to <i>PEAK</i> or <i>BASE</i> current.</p>
PEAK CUR.	<p>This parameter sets the <i>PEAK</i> weld current when in <i>PULSE</i> mode.</p>



Parameter	Description
<i>WELD</i>	This parameter sets the TIG WELD current in <i>STD</i> , <i>SLOPE</i> , <i>REPEAT</i> and <i>SPOT</i> modes when <i>PULSE</i> is OFF. This parameter also sets the STICK weld current.
<i>BASE</i> (Background Current)	This parameter sets the Background current when in Pulse TIG mode.
<i>SPOT TIME</i>	This parameter sets the duration of the <i>SPOT TIME</i> in <i>HF TIG</i> mode only.
<i>PULSE WIDTH</i>	This parameter sets the percentage on time of the <i>PULSE FREQUENCY</i> for PEAK weld current when the <i>PULSE</i> is ON.
<i>PULSE FREQ.</i>	This parameter sets the <i>PULSE FREQUENCY</i> when the <i>PULSE</i> is ON.
<i>DOWN SLOPE</i>	This parameter operates in TIG modes only and is used to set the time for the weld current to ramp down, after the torch trigger switch has been pressed, to <i>CRATER CUR.</i> This control is used to eliminate the crater that can form at the completion of a weld.
<i>CRATER CUR.</i>	This parameter operates in <i>SLOPE</i> or <i>REPEAT</i> (4T) TIG modes only and is used to set the finish current for TIG. The CRATER Current remains ON until the torch trigger switch is released after it has been depressed.
<i>POST-FLOW</i> 	This parameter operates in TIG modes only and is used to adjust the post gas flow time once the arc has extinguished. This control is used to dramatically reduce oxidation of the tungsten electrode.
 SAUVEGARDER CHARGER	The SAVE/LOAD buttons are used to save and retrieve a total number of 5 programs into the 400 TS memory.

Table 4 – Weld Parameter Descriptions for ArcMaster 400 TS

4.04 Weld Parameters for ArcMaster 400 TS

Weld Parameter	Parameter Range	Factory Setting	Incremental Unit	Weld Mode		
				STICK	HF TIG	LIFT TIG
<i>PRE-FLOW</i>	0.0 to 1.0 sec	0.1 sec	0.1 sec	No	Yes	Yes
<i>HOT START</i>	0 to 70A	20A	1A	Yes	Yes	No
<i>INITIAL CUR.</i>	5 to 400A	30A	1A	No	Yes	Yes
<i>UP SLOPE</i>	0 to 15 sec	1 sec	0.1 sec	No	Yes	Yes
<i>PEAK CUR.</i>	5 to 400A	120A	1A	No	Yes	Yes
<i>WELD CUR (TIG)</i>	5 to 400A	80A	1A	No	Yes	Yes
<i>WELD CUR (STICK)</i>	5 to 400A	80A	1A	Yes	No	No
<i>SPOT TIME</i>	0.5 to 5.0 sec	2 sec	0.1 sec	No	Yes	Yes
<i>PULSE WIDTH</i>	15 to 80%	50%	1%	No	Yes	Yes
<i>PULSE FREQ.</i>	0.5 to 500Hz	100.0Hz	See Table 6	No	Yes	Yes
<i>DOWN SLOPE</i>	0 to 25 sec	3 sec	0.1 sec	No	Yes	Yes
<i>CRATER CUR.</i>	5 to 40A	30A	1A	No	Yes	Yes
<i>POST-FLOW</i>	0.0 to 60 sec	10 sec	0.1 sec	No	Yes	Yes

Table 5 – Weld Parameters for ArcMaster 400 TS

<i>PULSE FREQ. Range</i>	Incremental Unit
0.5 to 20Hz	0.1Hz
20 to 100Hz	1Hz
100 to 500Hz	5Hz

Table 6 – *PULSE FREQ.* Range and Incremental Units

4.05 Power Source Features

Feature	Description
<i>New Digital Control</i>	<ul style="list-style-type: none"> • Almost all welding parameters are adjustable.
<i>Touch Panel Switches</i>	<ul style="list-style-type: none"> • Touch switches eliminate mechanical damage.
<i>Front Control Cover</i>	<ul style="list-style-type: none"> • Protects front panel controls.
<i>Digital Meter</i>	<ul style="list-style-type: none"> • Displays selected weld parameter value. • Displays weld current when welding. • Displays weld current for 20 seconds after weld has been completed. • A selected weld parameter value can be adjusted at any time even while welding.
<i>Intelligent Fan Control</i>	<ul style="list-style-type: none"> • The intelligent cooling system is designed to reduce dust and foreign material build-up, whilst providing optimum cooling. • Fan speed reduces approximately 30 seconds after machine is turned ON. • Fan speed increases when internal components reaches operating temperature.
<i>ON/OFF Switch</i>	<ul style="list-style-type: none"> • Primary voltage Supply ON/OFF switch located on rear panel.
<i>Save/Load Function</i>	<ul style="list-style-type: none"> • A total number of 5 programs can be saved into the 400 TS memory. <p>SAVE the Current Weld Parameters into Memory</p> <ul style="list-style-type: none"> • Press and HOLD the <i>SAVE</i> button. Beep will sound and Digital Meter will show a number 1. • Select a memory location by rotating the control knob, 1 to 5 is displayed on the meter. • After selecting the desired memory location (i.e. 1 to 5), press the right scroll button and the machine will give a beep to confirm the weld parameters from the control panel are saved. <p>LOAD (retrieve) a Program to Control Panel</p> <ul style="list-style-type: none"> • Press and HOLD the <i>LOAD</i> button. Beep will sound and Digital Meter will show a number 1. • Select a memory location by rotating the control knob, 1 to 5 is displayed on the meter. <p>After selecting the desired memory location (i.e. 1 to 5), press the right scroll button and the machine will give a beep to confirm the weld parameters are loaded onto the control panel.</p>

Feature	Description
<p><i>Voltage Reduction Device (VRD)</i></p> <p><i>See Section 11 for de-activation instructions</i></p>	<p>Reduces the OCV when the power supply is not in use. Eliminates the need for add on voltage reducers and has no effect on arc starting.</p> <ul style="list-style-type: none"> • VRD fully complies to IEC 60974-1. • When Stick mode is selected the green VRD light is ON when not welding and red when welding. • When in TIG modes VRD is OFF.
<p><i>Control Knob</i></p>	<ul style="list-style-type: none"> • For the selected weld parameter, rotating the knob clockwise increases the parameter. • Rotating the knob counter-clockwise decreases the parameter. • A selected weld parameter value can be adjusted at any time even while welding. • Pushing the knob in displays actual arc voltage.
<p><i>Self Diagnosis using Error Codes</i></p>	<ul style="list-style-type: none"> • An error code is displayed on the <i>Digital Meter</i> when a problem occurs with Primary supply voltage or internal component problems. Refer to Troubleshooting Guide.

SECTION 5: SET-UP FOR SMAW (STICK) AND GTAW (TIG)

Conventional operating procedures apply when using the Welding Power Source, i.e. connect work lead directly to work piece and electrode lead is used to hold electrode. Wide safety margins provided by the coil design ensure that the Welding Power Source will withstand short-term overload without adverse effects. The welding current range values should be used as a guide only. Current delivered to the arc is dependent on the welding arc voltage, and as welding arc voltage varies between different classes of electrodes, welding current at any one setting would vary according to the type of electrode in use. The operator should use the welding current range values as a guide, then finally adjust the current setting to suit the application.



WARNING 7

Before connecting the work clamp to the work and inserting the electrode in the electrode holder make sure the Primary power supply is switched OFF.

CAUTION 3

Remove any packaging material prior to use. Do not block the air vents at the front or rear or sides of the Welding Power Source.

CAUTION 4

DO NOT change the Weld Mode or Weld Process Mode Until after POST-FLOW time has finished.

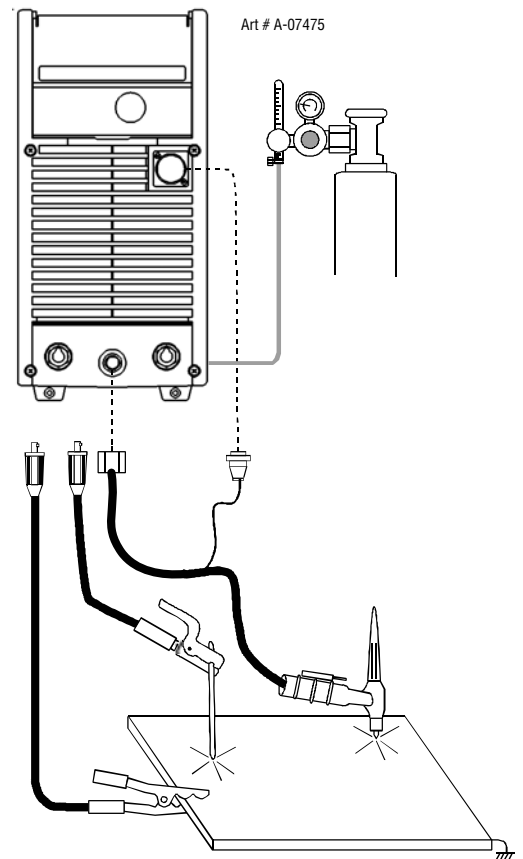


Figure 6. 400 TS Set-up

SECTION 6: SEQUENCE OF OPERATION



NOTE: Scroll Buttons are used to select the parameters to be set. The LED's show which function is being adjusted on the weld sequence graph. Refer to Symbols Table located in the front of the manual for Symbol descriptions.

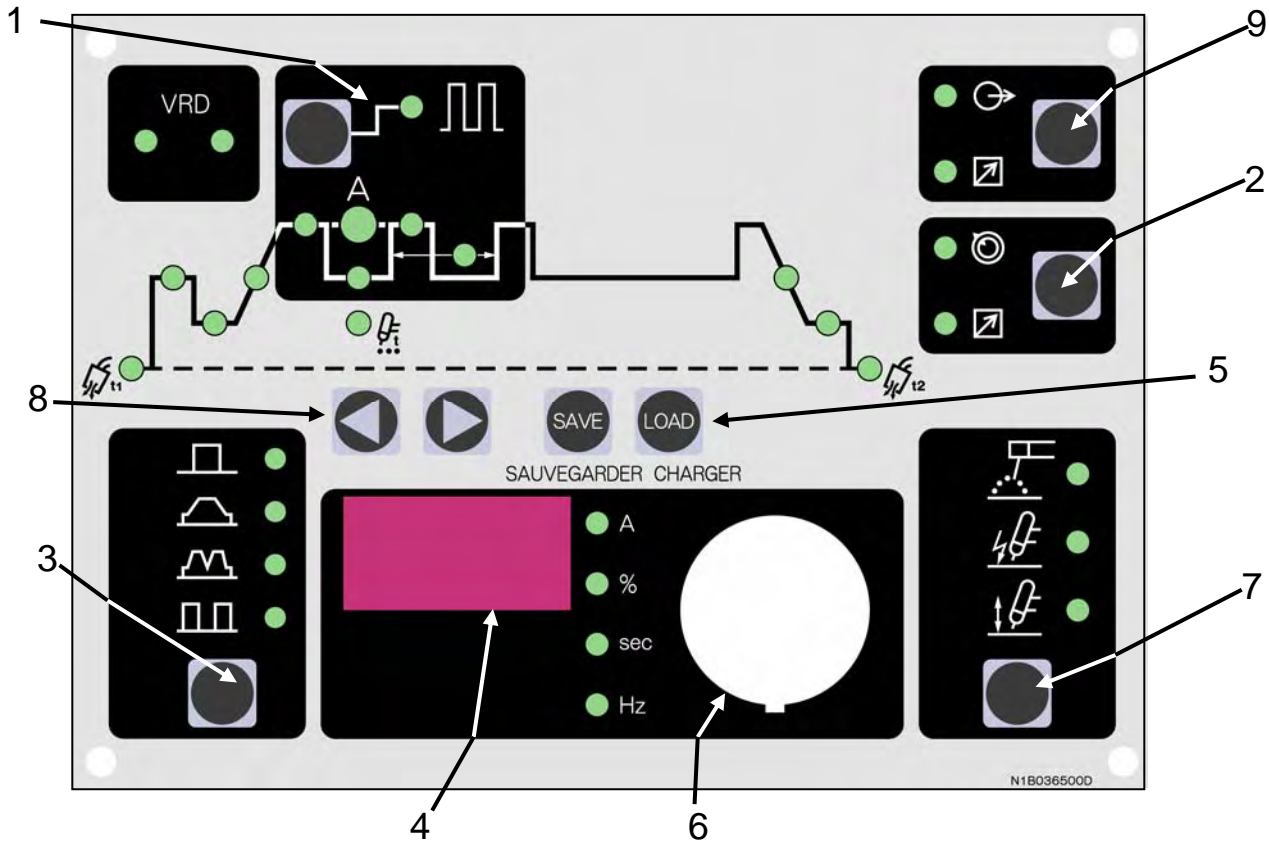


Figure 7. 400 TS Front Panel

1. **Pulse Function:** Pressing this button enables the TIG current pulse functions.
2. **Remote Current Function:** Pressing this button enables remote current functions.
3. **TIG Mode Functions:** Pressing this button scrolls through the output TIG function modes (Standard, Slope, Slope w/repeat, Spot).
4. **Digital LED Display:** Welding amperage and parameter values are displayed in this window. Internal warnings such as over temperature, low or high input voltage applied are signaled to the operator by a warning sound and error message on the screen.
5. **Save/Load Buttons:** By using the Save & Load buttons the operator can easily save up to 5 welding parameter programs.
6. **Control Knob:** Allows the operator to adjust the output amperage within the entire range of the power source and sets each parameter value.
7. **Process Button:** This button selects between STICK, HF TIG and Lift TIG mode.
8. **Scroll Buttons:** Used to select the parameters to be set. The LED's show which function is being adjusted on the Sequence Graph.
9. **Contactor Function:** Pressing this button enables Contactor functions.

6.01 Stick Welding

- Connect work lead to negative terminal
- Connect electrode lead to positive terminal
- Switch machine ON
- Set Contactor
- Connect remote control device if required

Use the Scroll Buttons to move to the parameter to be set. The LED will show which function is being adjusted on the weld sequence graph. Use the control knob to adjust each parameter.

- Set *HOT START*
- Set *WELD* current

Commence welding

6.02 HF TIG & Lift TIG Welding

- Connect work lead to positive terminal
- Connect TIG torch to gas terminal
- Switch machine ON
- Set weld current
- Connect remote control device. A remote control device is required for use during LIFT TIG and HF TIG operation. See section 4.01, section 2 "*Remote Control Socket*", for complete details of the remote device.

Use the Scroll Buttons to move to the parameter to be set. The LED will show which function is being adjusted on the weld sequence graph. Use the control knob to adjust each parameter.

- Set *PRE-FLOW*time
- Set *HOT START*current
- Set *POST-FLOW*time
- Set *WELD*current
- Set *POST-FLOW*time

Slope Mode Parameters if required

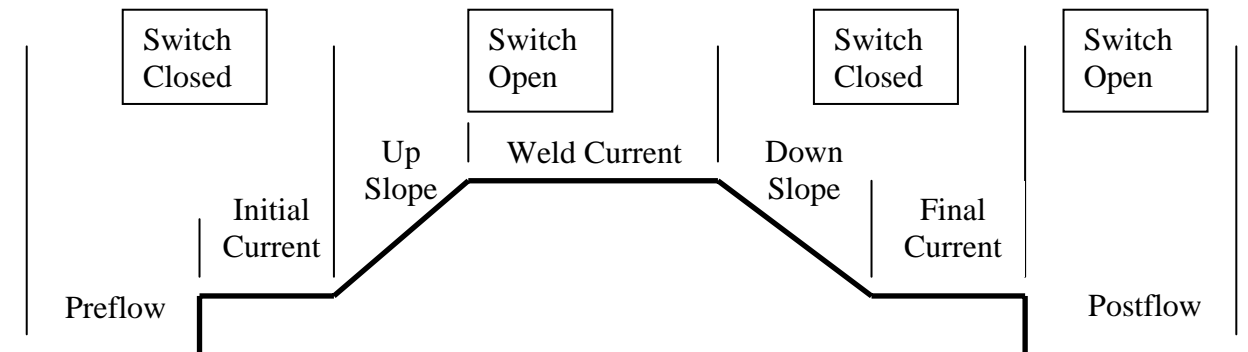
- Set *INITIAL CUR*current
- Set *UP SLOPE*time
- Set (WELD) *PEAK CUR*current
- Set *BASE*current
- Set *DOWN SLOPE*time
- Set *CRATER CUR*current

Pulse Mode Parameters if required

- Set *PULSE WIDTH*% for *PEAK CURRENT*
- Set *PEAK CURRENT*
- Set *PULSE FREQ*

Commence welding

6.02.01 Slope Mode Sequence



Note 5

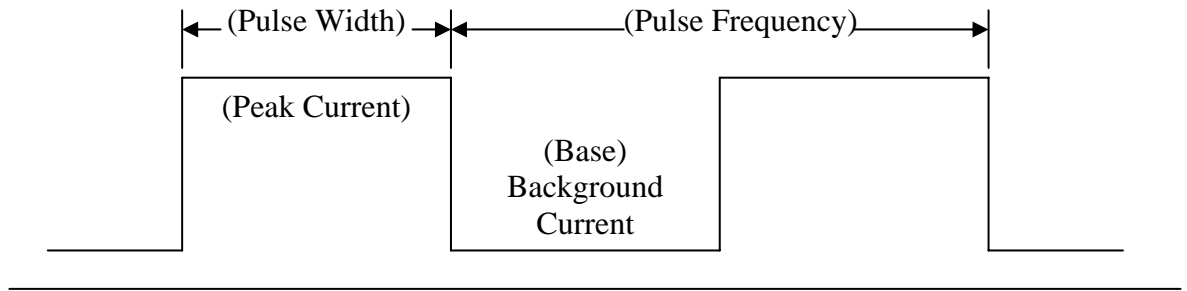
Slope function operates with a Remote ON/OFF device only.

- 1) To start Slope sequence Close remote switch contacts. Once the welding arc is established the Power Source will maintain initial current setting as long as the remote switch contacts are closed.
 - a) In the HF TIG mode, after Prewflow time High Frequency is present at the torch. When the torch is positioned close to the work the welding current will transfer to the work and establish the arc at the initial current setting.
 - b) In the Lift TIG mode, after preflow time Lift Start current is present at the torch. When the electrode is touched to the work and lifted off, the welding arc is established at the initial current setting.
- 2) Open Remote Switch – Current increases to weld current. Once welding arc has reached weld current the power source will maintain weld current as long as the remote switch contacts are open.
- 3) Close Remote Switch – Welding current decreases to final current setting. Once final welding current is reached the power source will maintain final current setting as long as the remote switch contacts are closed.
- 4) Open Remote Switch – Welding arc stops and post flow begins.

6.02.02 Slope Mode with Repeat Sequence

The repeat function is operated during the down slope cycle of the Slope Sequence and is active through the down slope period only. During the down slope period by opening the Remote Switch contacts the current will increase back to weld current. Within the Down Slope period the repeat function can be operated as many times as desired. To continue slope cycle and end slope sequence close remote switch contacts and allow weld current to reach final current setting. Once final current setting is reached opening the Remote Switch again will turn OFF the welding arc and post flow begins.

6.02.03 Pulse Controls



The Pulse controls are used primarily to control heat input. Pulse offers a number of advantages as follows:

- 1) Control puddle – size and fluidity (especially out of position)
- 2) Increase penetration
- 3) Travel speed control
- 4) Better consistent quality
- 5) Distortion on lighter or thinner materials

Pulse-current provides a system in which the welding current continuously changes between two levels. During the periods of Peak current, heating and fusion takes place, and during the background (base) current periods, cooling and solidification take place. Pulse Width is the time in one cycle the current stays at the peak current setting. Pulse Frequency measured in Hertz is the number of cycles per second the current travels between peak and background current settings. It is as if the foot rheostat were moved up and down to increase and decrease the welding current on a regular basis. The faster you moved the foot rheostat up and down the faster the frequency.

6.03 Save-Load Operation

A total number of 5 programs can be saved into the 400 TS memory.

***SAVE* the Current Weld Parameters into Memory**

- Press and HOLD the *SAVE* button. Beep will sound and Digital Meter display will show a number 1.
- Select a memory location by rotating the control knob, 1 to 5 is displayed on the meter.
- After selecting the desired memory location (i.e. 1 to 5), press the right scroll button and the machine will give a beep to confirm the weld parameters from the control panel are saved.

***LOAD* (retrieve) a Program to Control Panel**

- Press and HOLD the *LOAD* button. Beep will sound and Digital Meter display will show a number 1.
- Select a memory location by rotating the control knob, 1 to 5 is displayed on the meter.
- After selecting the desired memory location (i.e. 1 to 5), press the right scroll button and the machine will give a beep to confirm the weld parameters are loaded onto the control panel.

SECTION 7: BASIC TIG WELDING GUIDE

7.01 Electrode Polarity

Connect the TIG torch to the - / TORCH terminal and the work lead to the + / WORK terminal for direct current straight polarity. Direct current straight polarity is the most widely used polarity for DC TIG welding. It allows limited wear of the electrode since 70% of the heat is concentrated at the work piece.

7.02 Tungsten Electrode Current Ranges

Electrode Diameter	DC Current (Amps)
0.040" (1.0mm)	30 – 60
1/16" (1.6mm)	60 – 115
3/32" (2.4mm)	100 – 165
1/8" (3.2mm)	135 – 200
5/32" (4.0mm)	190 – 280
3/16" (4.8mm)	250 – 340

Table 7 – Current Ranges for Various Tungsten Electrode Sizes

7.03 Tungsten Electrode Types

Electrode Type (Ground Finish)	Welding Application	Features	Color Code
Thoriated 2%	DC welding of mild steel, stainless steel and copper.	Excellent arc starting, long life, high current carrying capacity.	Red
Zirconated 1%	High quality AC welding of aluminium, magnesium and their alloys.	Self cleaning, long life, maintains balled end, high current carrying capacity.	White
Ceriated 2%	AC & DC welding of mild steel, stainless steel, copper, aluminium, magnesium and their alloys.	Longer life, more stable arc, Easier starting, wider current range, narrower more concentrated arc.	Grey

Table 8 – Tungsten Electrode Types

7.04 Guide for Selecting Filler Wire Diameter

Filler Wire Diameter	AC Current Range (Amps)	DC Current Range (Amps)
1/16" (1.6 mm)	30 - 95	20 - 90
3/32" (2.4 mm)	125 - 160	65 - 115
1/8" (3.2 mm)	180 - 240	100 - 165
3/16" (4.8 mm)	220 - 320	200 - 350

Table 9 – Filler Wire Selection Guide

NOTE 6

The filler wire diameter specified in Table 9 is a guide only. Other diameter wires may be used according to the welding application.

7.05 Shielding Gas Selection

Alloy	Shielding Gas
Aluminium & alloys	Welding Argon, Argoshield 80T, 81T
Carbon Steel	Welding Argon
Stainless Steel	Welding Argon, Argoshield 71T, 80T, 81T
Nickel Alloy	Welding Argon, Argoshield 71T
Copper	Welding Argon, Argoshield 81T
Titanium	Welding Argon, Argoshield 80T, 81T

Table 10 – Shielding Gas Selection

7.06 TIG Welding Parameters for Low Carbon & Low Alloy Steel Pipe

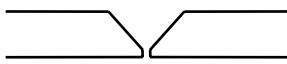
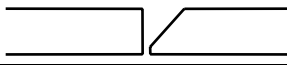

Electrode Type & Diameter	Current Range DC Amperes	Filler Rod for Root Pass	Joint Preparation
Thoriated 2% 3/32" (2.4 mm)	120 - 170	Yes	
Thoriated 2% 3/32" (2.4 mm)	100 - 160	Yes	
Thoriated 2% 3/32" (2.4 mm)	90 - 130	No	

Table 11 – TIG Welding Parameters for Low Carbon & Low Alloy Steel Pipe

7.07 Welding Parameters for Steel

Base Metal Thickness	DC Current for Mild Steel	DC Current for Stainless Steel	Tungsten Electrode Diameter	Filler Rod Diameter (if required)	Argon Gas Flow Rate Liters/min	Joint Type
0.040" 1.0mm	35-45 40-50	20-30 25-35	0.040" 1.0mm	1/16" 1.6mm	5-7	Butt/Corner Lap/ Fillet
0.045" 1.2mm	45-55 50-60	30-45 35-50	0.040" 1.0mm	1/16" 1.6mm	5-7	Butt/Corner Lap/ Fillet
1/16" 1.6mm	60-70 70-90	40-60 50-70	1/16" 1.6mm	1/16" 1.6mm	7	Butt/Corner Lap/ Fillet
1/8" 3.2mm	80-100 90-115	65-85 90-110	1/16" 1.6mm	3/32" 2.4mm	7	Butt/Corner Lap/ Fillet
3/16" 4.8mm	115-135 140-165	100-125 125-150	3/32" 2.4mm	1/8" 3.2mm	10	Butt/Corner Lap/ Fillet
1/4" 6.4mm	160-175 170-200	135-160 160-180	1/8" 3.2mm	5/32" 4.0mm	10	Butt/Corner Lap/ Fillet

Table 12 – DC TIG Welding Parameters

SECTION 8: BASIC ARC WELDING GUIDE

8.01 Electrode Polarity

Stick electrodes are generally connected to the '+' terminal and the work lead to the '-' terminal but if in doubt consult the electrode manufacturers literature.

8.02 Effects of Stick Welding Various Materials

High tensile and alloy steels

The two most prominent effects of welding these steels are the formation of a hardened zone in the weld area, and, if suitable precautions are not taken, the occurrence in this zone of under-bead cracks. Hardened zone and under-bead cracks in the weld area may be reduced by using the correct electrodes, preheating, using higher current settings, using larger electrode sizes, short runs for larger electrode deposits or tempering in a furnace.

Manganese steels

The effect on manganese steel of slow cooling from high temperatures is to embrittle it. For this reason it is absolutely essential to keep manganese steel cool during welding by quenching after each weld or skip welding to distribute the heat.

Cast Iron

Most types of cast iron, except white iron, are weldable. White iron, because of its extreme brittleness, generally cracks when attempts are made to weld it. Trouble may also be experienced when welding white-heart malleable, due to the porosity caused by gas held in this type of iron.

Copper and alloys

The most important factor is the high rate of heat conductivity of copper, making preheating of heavy sections necessary to give proper fusion of weld and base metal.

Types of Electrodes

Arc Welding electrodes are classified into a number of groups depending on their applications. There are a great number of electrodes used for specialized industrial purposes which are not of particular interest for everyday general work. These include some low hydrogen types for high tensile steel, cellulose types for welding large diameter pipes, etc. The range of electrodes dealt with in this publication will cover the vast majority of applications likely to be encountered; are all easy to use and all will work on even the most basic of welding machines.

Metals being joined	Electrode	Comments
Mild steel	6013	Ideal electrodes for all general purpose work. Features include outstanding operator appeal, easy arc starting and low spatter.
Mild steel	7014	All positional electrode for use on mild and galvanized steel furniture, plates, fences, gates, pipes and tanks etc. Especially suitable for vertical-down welding.
Cast iron	99% Nickel	Suitable for joining all cast irons except white cast iron.
Stainless steel	318L-16	High corrosion resistance. Ideal for dairy work, etc. on stainless steels.
Copper, Bronze, Brass, etc.	Bronze 5.7 ERCUSI-A	Easy to use electrode for marine fittings, water taps and valves, water trough float arms, etc. Also for joining copper to steel and for bronze overlays on steel shafts.
High alloy steels, dissimilar metals, crack resistant, all hard-to-weld jobs.	312-16	It will weld most problematical jobs such as springs, shafts, broken joints mild steel to stainless and alloy steels. Not suitable for Aluminium.

Table 13 – Types of Electrodes

SECTION 9: ROUTINE MAINTENANCE

The only routine maintenance required for the power supply is a thorough cleaning and inspection, with the frequency depending on the usage and the operating environment.

The unit should be wiped clean as necessary with solvents that are recommended for cleaning electrical apparatus. Turn Power Switch to OFF before proceeding. Internal cleaning of the unit should be done every 6 months by an authorized Thermal Arc Service Center to remove any accumulated dirt and dust. This may need to be done more frequently under exceptionally dirty conditions.

CAUTION 5

Do not blow air into the power supply during cleaning. Blowing air into the unit can cause metal particles to interfere with sensitive electrical components and cause damage to the unit.

SECTION 10: BASIC TROUBLESHOOTING



WARNING 8

There are extremely dangerous voltages and power levels present inside this product. Do not attempt to open or repair unless you are an accredited Thermal Arc Service Agent and you have had training in power measurements and troubleshooting techniques.

If major complex subassemblies are faulty, then the Welding Power Source must be returned to an accredited Thermal Arc Service Agent for repair.

The basic level of troubleshooting is that which can be performed without special equipment or knowledge.

10.01 TIG Welding Problems

Weld quality is dependent on the selection of the correct consumables, maintenance of equipment and proper welding technique.

Description	Possible Cause	Remedy
1 Excessive bead build-up or poor penetration or poor fusion at edges of weld.	Welding current is too low.	Increase weld current and/or faulty joint preparation.
2 Weld bead too wide and flat or undercut at edges of weld or excessive burn through.	Welding current is too high.	Decrease weld current.
3 Weld bead too small or insufficient penetration or ripples in bead are widely spaced apart.	Travel speed too fast.	Reduce travel speed.
4 Weld bead too wide or excessive bead build up or excessive penetration in butt joint.	Travel speed too slow.	Increase travel speed.
5 Uneven leg length in fillet joint.	Wrong placement of filler rod.	Re-position filler rod.

Description	Possible Cause	Remedy
6 Electrode melts when arc is struck.	Electrode is connected to the '+' terminal.	Connect the electrode to the '-' terminal.
7 Dirty weld pool.	<p>A Electrode contaminated through contact with work piece or filler rod material.</p> <p>B Gas contaminated with air.</p>	<p>A Clean the electrode by grinding off the contaminates.</p> <p>B Check gas lines for cuts and loose fitting or change gas cylinder.</p>
8 Electrode melts or oxidizes when an arc is struck.	<p>A No gas flowing to welding region.</p> <p>B Torch is clogged with dust.</p> <p>C Gas hose is cut.</p> <p>D Gas passage contains impurities.</p> <p>E Gas regulator turned OFF.</p> <p>F Torch valve is turned OFF.</p> <p>G The electrode is too small for the welding current.</p>	<p>A Check the gas lines for kinks or breaks and gas cylinder contents.</p> <p>B Clean torch.</p> <p>C Replace gas hose.</p> <p>D Disconnect gas hose from torch then raise gas pressure and blow out impurities.</p> <p>E Turn ON.</p> <p>F Turn ON.</p> <p>G Increase electrode diameter or reduce the welding current.</p>
9 Poor weld finish.	Inadequate shielding gas.	Increase gas flow or check gas line for gas flow problems.
10 Arc flutters during TIG welding.	<p>A Tungsten electrode is too large for the welding current.</p> <p>B Absence of oxides in the weld pool.</p>	<p>A Select the right size electrode. Refer to Basic TIG Welding guide.</p> <p>B Refer Basic TIG Welding Guide for ways to reduce arc flutter.</p>
11 Welding arc cannot be established.	<p>A Work clamp is not connected to the work piece or the work/torch leads are not connected to the right welding terminals.</p> <p>B Torch lead is disconnected.</p> <p>C Gas flow incorrectly set, cylinder empty or the torch valve is OFF.</p>	<p>A Connect the work clamp to the work piece or connect the work/torch leads to the right welding terminals.</p> <p>B Connect it to the '-' terminal.</p> <p>C Select the right flow rate, change cylinders or turn torch valve ON.</p>

Description	Possible Cause	Remedy
12 Arc start is not smooth.	<p>A Tungsten electrode is too large for the welding current.</p> <p>B The wrong electrode is being used for the welding job.</p> <p>C Gas flow rate is too high.</p> <p>D Incorrect shielding gas is being used.</p> <p>E Poor work clamp connection to work piece.</p>	<p>A Select the right size electrode. Refer to Basic TIG Welding Guide.</p> <p>B Select the right electrode type. Refer to Basic TIG Welding Guide.</p> <p>C Select the correct rate for the welding job. Refer to Basic TIG Welding Guide.</p> <p>D Select the right shielding gas. Refer to Basic TIG Welding Guide.</p> <p>E Improve connection to work piece.</p>

10.02 Stick Welding Problems

Description	Possible Cause	Remedy
1 Gas pockets or voids in weld metal (Porosity).	<p>A Electrodes are damp.</p> <p>B Welding current is too high.</p> <p>C Surface impurities such as oil, grease, paint, etc.</p>	<p>A Dry electrodes before use.</p> <p>B Reduce welding current.</p> <p>C Clean joint before welding.</p>
2 Crack occurring in weld metal soon after solidification commences.	<p>A Rigidity of joint.</p> <p>B Insufficient throat thickness.</p> <p>C Cooling rate is too high.</p>	<p>A Redesign to relieve weld joint of severe stresses or use crack resistance electrodes.</p> <p>B Travel slightly slower to allow greater build up in throat.</p> <p>C Preheat plate and cool slowly.</p>
3 A gap is left by failure of the weld metal to fill the root of the weld.	<p>A Welding current is too low.</p> <p>B Electrode too large for joint.</p> <p>C Insufficient gap.</p> <p>D Incorrect sequence.</p>	<p>A Increase welding current.</p> <p>B Use smaller diameter electrode.</p> <p>C Allow wider gap.</p> <p>D Use correct build-up sequence.</p>

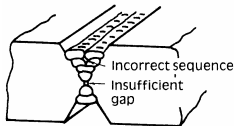


Figure 8. Example of Insufficient Gap or Incorrect Sequence

<p>4 Portions of the weld run do not fuse to the surface of the metal or edge of the joint.</p>	<p>A Small electrodes used on heavy cold plate. B Welding current is too low. C Wrong electrode angle. D Travel speed of electrode is too high. E Scale or dirt on joint surface.</p>	<p>A Use larger electrodes and pre-heat the plate. B Increase welding current. C Adjust angle so the welding arc is directed more into the base metal. D Reduce travel speed of electrode. E Clean surface before welding.</p>
---	---	--

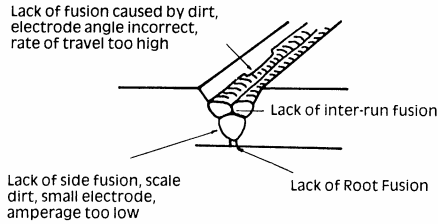


Figure 9. Example of Lack of Fusion

<p>5 Non-metallic particles are trapped in the weld metal (slag inclusion).</p>	<p>A Non-metallic particles may be trapped in undercut from previous run. B Joint preparation too restricted. C Irregular deposits allow slag to be trapped. D Lack of penetration with slag trapped beneath weld bead. E Rust or mill scale is preventing full fusion. F Wrong electrode for position in which welding is done.</p>	<p>A If bad undercut is present, clean slag out and cover with a run from a smaller diameter electrode. B Allow for adequate penetration and room for cleaning out the slag. C If very bad, chip or grind out irregularities. D Use smaller electrode with sufficient current to give adequate penetration. Use suitable tools to remove all slag from corners. E Clean joint before welding. F Use electrodes designed for position in which welding is done, otherwise proper control of slag is difficult.</p>
---	---	--

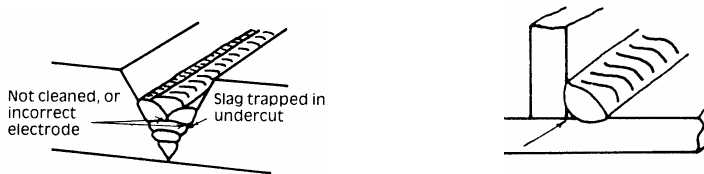


Figure 10. Examples of Slag Inclusion

10.03 Power Source Problems

Description	Possible Cause	Remedy
1 The welding arc cannot be established.	A The Primary supply voltage has not been switched ON. B The Welding Power Source switch is switched OFF. C Loose connections internally.	A Switch ON the Primary supply voltage. B Switch ON the Welding Power Source. C Have an accredited Thermal Arc Service Agent repair the connection.
2 Maximum output welding current cannot be achieved with nominal Mains supply voltage.	Defective control circuit.	Have an accredited Thermal Arc Service Agent repair the connection.
3 Welding current reduces when welding.	A Loose welding cable connections. B Incorrect welding cable size. C Improper input connections. D Poor electrode condition. E Wrong welding polarity.	A Tighten all welding cable connections. B Use proper size and type of cable. C Refer to Section 3.03.01 - Electrical Input Requirements. D Replace electrode. E Verify output torch connections.
4 No gas flow when the torch trigger switch is depressed.	A Gas hose is cut. B Gas passage contains impurities. C Gas regulator turned OFF. D Torch trigger switch lead is disconnected or switch/cable is faulty.	A Replace gas hose. B Disconnect gas hose from the rear of Power Source then raise gas pressure and blow out impurities. C Turn gas regulator ON. D Reconnect lead or repair faulty switch/cable.

Description	Possible Cause	Remedy
<p>5 Gas flow won't shut OFF.</p>	<p>A Weld Mode (<i>STD, SLOPE, REPEAT</i> or <i>SPOT</i>) was changed before <i>POST-FLOW</i> gas time had finished.</p> <p>B Gas valve is faulty.</p> <p>C Gas valve jammed open.</p> <p>D <i>POST-FLOW</i> control is set to 60 sec.</p>	<p>A Strike an arc to complete the weld cycle. OR Switch machine OFF then ON to reset solenoid valve sequence.</p> <p>B Have an accredited Thermal Arc Service Agent repair or replace the gas valve.</p> <p>C Have an accredited Thermal Arc Service Agent repair or replace the gas valve.</p> <p>D Reduce <i>POST-FLOW</i> time.</p>
<p>6 The TIG electrode has been contaminated due to the gas flow shutting OFF before the programmed <i>POST-FLOW</i> time has elapsed.</p>	<p>The Weld Process Mode (<i>STICK, HF TIG</i> or <i>LIFT TIG</i>) was changed before <i>POST-FLOW</i> gas time had finished.</p>	<p>Do not change Weld Process Mode before the <i>POST-FLOW</i> gas time had finished.</p>

SECTION 11: VOLTAGE REDUCTION DEVICE (VRD)

11.01 VRD Specification

Description	ArcMaster 400 TS	Notes
VRD Open Circuit Voltage	15.3 to 19.8V	Open circuit voltage between welding terminals.
VRD Resistance	148 to 193 ohms	The required resistance between welding terminals to turn ON the welding power.
VRD Turn OFF Time	0.2 to 0.3 seconds	The time taken to turn OFF the welding power once the welding current has stopped.

11.02 VRD Maintenance

Routine inspection and testing (power source)

An inspection of the power source, an insulation resistance test and an earth resistance test shall be carried out in accordance with clause 4.1 of **AS 1647.2**

- a) For transportable equipment, at least once every 3 months.
- b) For fixed equipment, at least once every 12 months.

The owners of the equipment shall keep a suitable record of the periodic tests.

Note 7

A transportable power source is any equipment that is not permanently connected and fixed in the position in which it is operated.

In addition to the above tests and specifically in relation to the VRD fitted to this machine, the following periodic tests should also be conducted by an accredited Thermal Arc service agent.

Description	AS3195 & IEC 60974-1 Requirements
VRD Open Circuit Voltage	Less than 20V; at Vin=230V or 460V
VRD Turn ON Resistance	Less than 200 ohms
VRD Turn OFF Time	Less than 0.3 seconds

If this equipment is used in a hazardous location or environments with a high risk of electrocution then the above tests should be carried out prior to entering this location.

11.03 Switching VRD ON/OFF

Switch the machine OFF.

- a) Remove the clear plastic cover from the control panel. (see Figure 11)

Lift up the cover so it rests on the top of the unit.

Place a small flat bladed screw driver between the cover hinge on the front panel.

Gently lift the cover hinge out of the front cover mounting hole.

Remove the control's clear plastic cover.

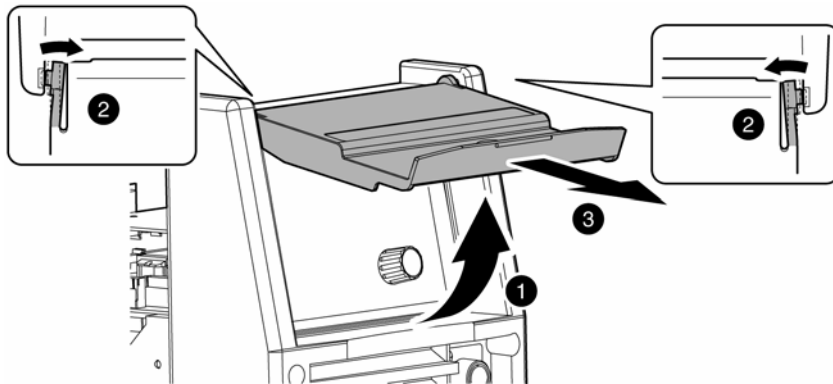


Figure 11. VRD ON/OFF Step A

- b) Remove four mounting screws from the control panel. (see Figure 12)

- c) Access the VRD control by gently prying back the front panel controls to reveal the VRD ON/OFF potentiometer. (see Figure 4)

CAUTION 6

Do not pull back the front panel with excessive force as this will unplug control PCB. Plugging the control PCB back into the front panel controls can only be achieved by removing the side covers.

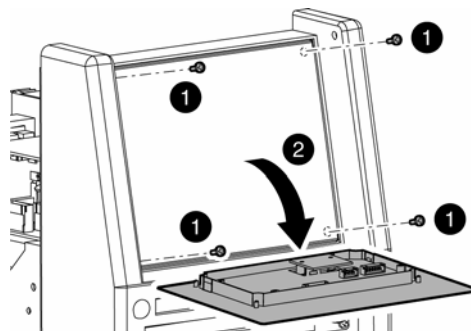


Figure 12. VRD ON/OFF Step B,C

d) Turning the VRD ON/OFF. (see Figure 13)

To turn VRD ON: rotate the trim potentiometer (VR1) on the display PCB fully clockwise. When VRD is turned ON check that it operates as per VRD Specifications on page 47.

To turn VRD OFF: rotate the trim potentiometer (VR1) on the display PCB fully counter-clockwise.



WARNING 9

The VRD ON/OFF trim potentiometer MUST ONLY be positioned fully clockwise OR fully counter-clockwise as the VRD function will be unknown for every other position.

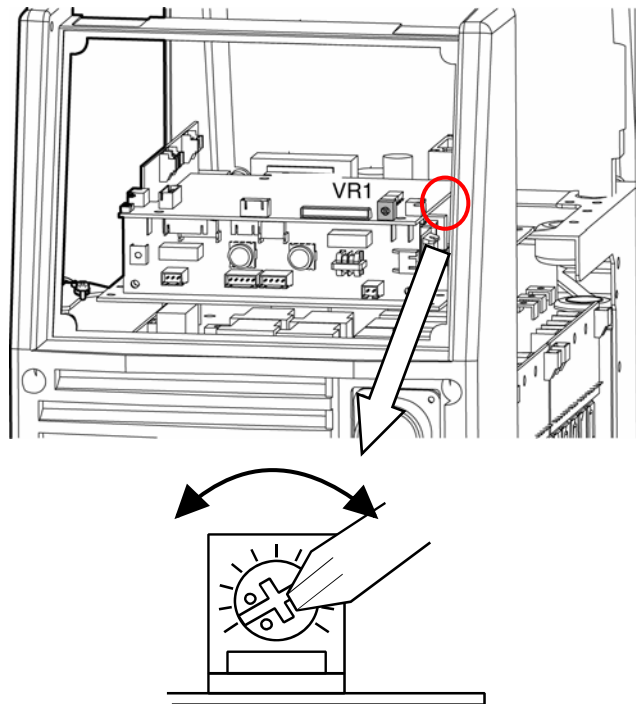


Figure 13. VRD ON/OFF Step D

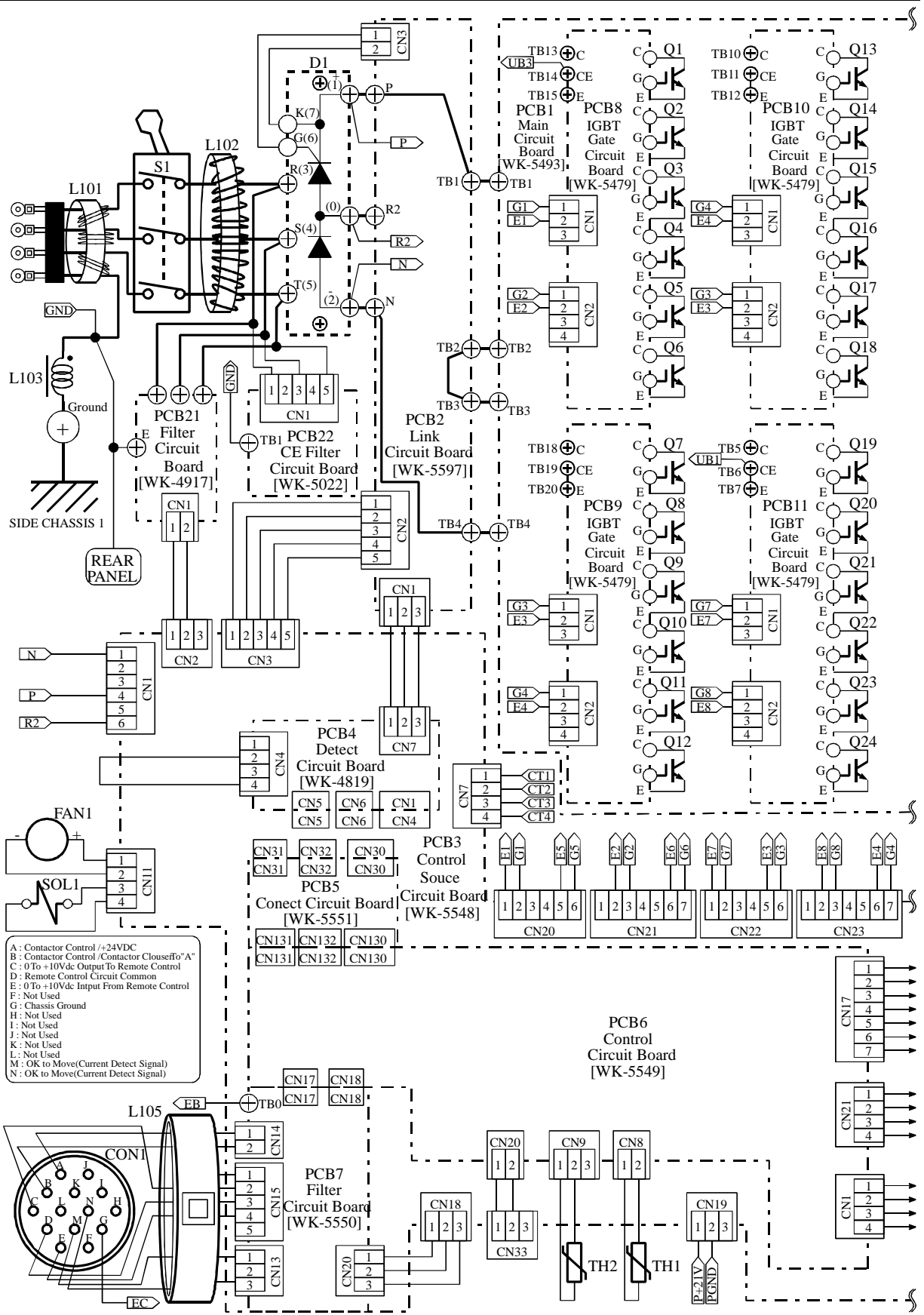
SECTION 12: POWER SOURCE ERROR CODES

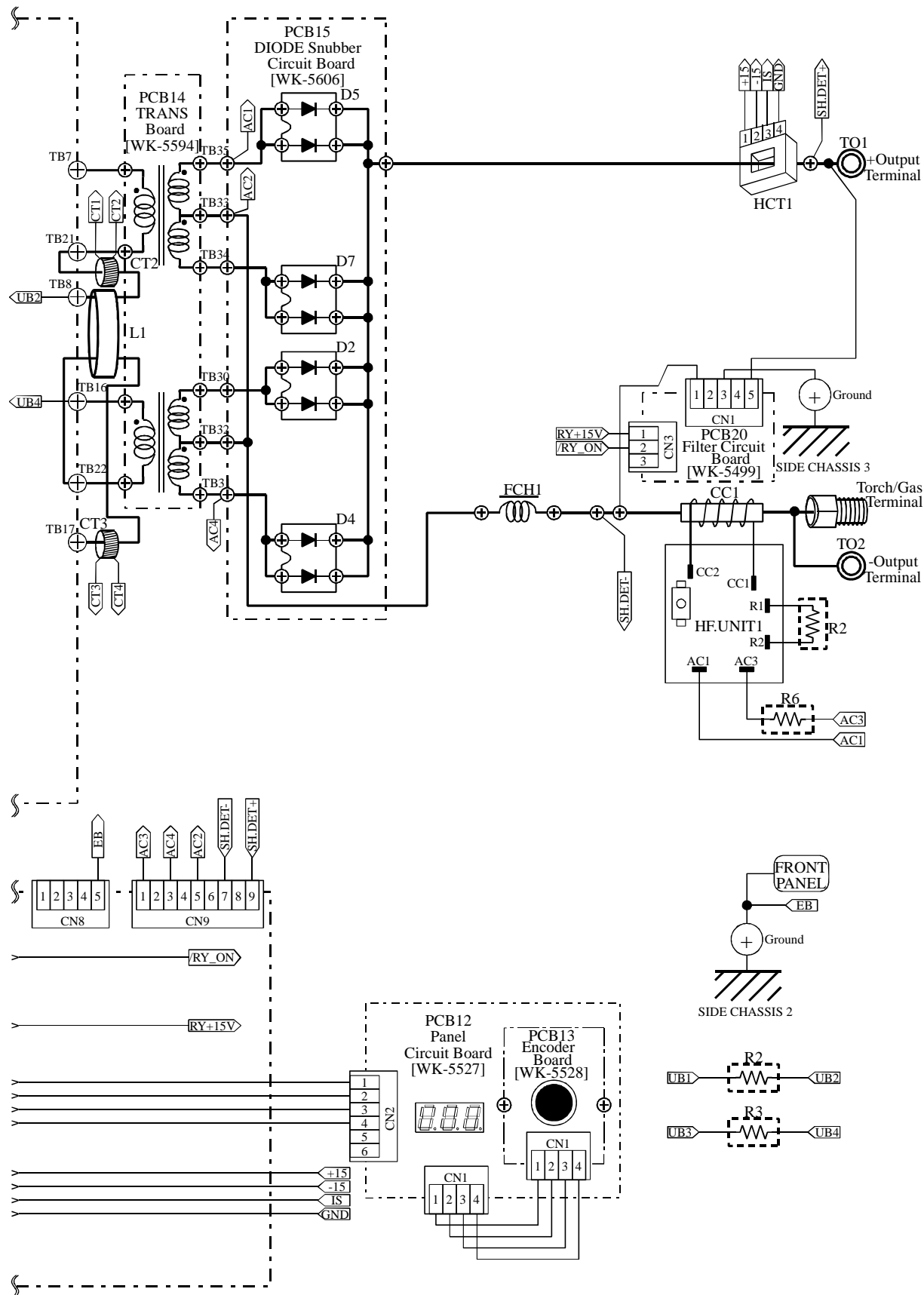
Description	Possible Cause	Remedy	Remarks
1 <u>E01 error code displayed</u> Temperature sensor TH1 (protects IGBTs) is greater than 80°C for about 1 second.	A The Welding Power Source's duty cycle has been exceeded. B Fan ceases to operate. C Air flow is restricted by vents being blocked.	A Let Power Source cool down then keep within its duty cycle. B Have an accredited Thermal Arc Service Agent investigate. C Unblock vents then let Power Source cool down.	Weld current ceases. Buzzer sounds constantly. Fan operates at max speed. E01 resets when TH1 decreases to 70°C for about 30 seconds.
2 <u>E02 error code displayed</u> Temperature sensor TH2 (protects secondary diodes) is greater than 80°C for about 1 second.	A The Welding Power Source's duty cycle has been exceeded. B Fan ceases to operate. C Air flow is restricted by vents being blocked.	A Let Power Source cool down then keep within its duty cycle. B Have an accredited Thermal Arc Service Agent investigate. C Unblock vents then let Power Source cool down.	Weld current ceases. Buzzer sounds constantly. Fan operates at max speed. E02 resets when TH1 decreases to 70°C for about 30 seconds.
3 <u>E03 error code displayed</u> Primary (input) current too high.	A Primary current is too high because welding arc is too long. B Mains supply voltage is more than 10% below nominal voltage.	A Reduce length of welding arc. B Have an accredited Thermal Arc Service Agent or a qualified electrician check for low Mains voltage.	Weld current ceases. Buzzer sounds constantly. Switch machine OFF then ON to reset E03 error.
4 <u>E04 error code displayed</u> Output voltage exceeds the secondary voltage specification.	TIG torch cable and/or work lead are too long or leads are coiled.	Reduce the length of the TIG torch cable and/or work lead or un-coiled leads.	Weld current ceases. Buzzer sounds constantly. Switch machine OFF then ON to reset E04 error.
5 <u>E11 error code displayed</u> Over Primary supply (input) voltage at primary capacitors is exceeded for one second.	Primary supply voltage is greater than the nominal voltage plus 10%.	Have an accredited Thermal Arc Service Agent or a qualified electrician check the Primary voltage.	Weld current ceases. Buzzer sounds constantly. Error code E11 automatically will reset when the voltage reduces.

Description	Possible Cause	Remedy	Remarks
6 <u>E14 error code displayed</u> Under mains supply (input) voltage warning primary capacitors is reduced for one second.	Mains supply voltage is less than the nominal operating voltage less 10%.	Have an accredited Thermal Arc Service Agent or a qualified electrician check the Mains voltage.	Weld current available. Buzzer sounds intermittently. Error code E14 automatically will reset when the voltage increases.
7 <u>E12 error code displayed</u> Under mains supply (input) voltage primary capacitors is reduced for one second.	Mains supply voltage is down to a dangerously low level.	Have an accredited Thermal Arc Service Agent or a qualified electrician check the Mains voltage.	Weld current ceases. Buzzer sounds constantly. Error code E12 automatically will reset when the voltage reduces.
8 <u>E81 error code displayed</u> Wrong Primary supply (input) voltage connected.	When 3 phase machine is first turned ON with the wrong Primary supply (input) voltage connected.	Have an accredited Thermal Arc Service Agent or a qualified electrician check the Mains voltage.	No weld current is available. Buzzer sounds constantly. Switch machine OFF.
9 <u>E82 error code displayed</u> Link switch plug not connected.	Link switch plug not connected.	Have an accredited Thermal Arc Service Agent check connector plug on input PCB.	No weld current is available. Buzzer sounds constantly. Switch machine OFF.
10 <u>E83 error code displayed</u> CPU checks mains supply (input) voltage when the ON /OFF switch on rear panel of machine is turned ON.	The Primary supply (input) voltage fluctuates and is not stable.	Have an accredited Thermal Arc Service Agent check connector plug on input PCB and the Mains voltage.	No weld current is available. Buzzer sounds constantly. Switch machine OFF then ON to reset E83 error.

Description	Possible Cause	Remedy	Remarks
11 <u>E93 error code displayed</u> Memory chip (EEPROM) on control PCB can not read/write weld parameters.	Memory chip (EEPROM) error.	Have an accredited Thermal Arc Service Agent check the control PCB.	Weld current ceases. Buzzer sounds constantly. Switch machine OFF.
12 <u>E94 error code displayed</u> Temperature sensor TH1 for IGBTs or sensor TH2 for secondary diodes are open circuit.	The Welding Power Source's temperature sensors have malfunctioned.	Have an accredited Thermal Arc Service Agent check or replace the temperature sensors.	Weld current ceases. Buzzer sounds constantly. Switch machine OFF.
13 <u>E99 error code displayed</u> Mains supply (input) voltage has been turned OFF but control circuit has power from the primary capacitors.	A Main ON/OFF switch on machine has been turned OFF. B Mains supply (input) voltage has been turned OFF.	A Turn ON/OFF switch ON. B Have an accredited Thermal Arc Service Agent or a qualified electrician check the Mains voltage and fuses.	Weld current ceases. Buzzer sounds constantly. Must switch machine OFF then ON to reset E99 error.

APPENDIX A - INTERCONNECT DIAGRAM





APPENDIX B - ARCMaster 400 TS ACCESSORIES

PART NO.	DESCRIPTION
W4000300	Thermal Arc Inverter Cart
W4001301	Water Recirculator 400v
10-2007	Remote Foot control 7.6m lead and plug
10-2005	Remote Hand Pendant 7.6m lead and plug
10-2096	14 Pin Plug for Remote or TIG Torch Button
10-2097	Cable Clamp for 14 Pin Plug

LIMITED WARRANTY AND SCHEDULE

This information applies to Thermadyne products that were purchased in the United Kingdom

April 2006

Thermadyne guarantees the proposed product to be free from defects in material or workmanship when operated in accordance with the written instructions as defined in the owner's manual supplied with the machine. Thermadyne welding products are manufactured for use by commercial and industrial users and trained personnel with experience in the use and maintenance of electrical welding and cutting equipment.

Thermadyne warranty will not apply to:

1. Equipment that has been modified by any other party other than Thermadyne's own service personnel or with prior written consent obtained from Thermadyne service department (UK).
2. Equipment that has been used beyond the specifications established in the owners manual.
3. Installation not in accordance with the installation/service manual.
4. Failure to clean and maintain the machine as set forth in the owner, installation or service manual.

If warranty is being sought, please contact Thermadyne's UK warranty department for a warranty authorization returns form.

Welding Equipment - Limited Warranty Period	
Product	Period
200S, 300S, 400S, 200TS, 300TS, 400TS, 400 MST, 200AC/DC, 300AC/DC, PowerMaster 320SP, 400SP, 500SP, Fabricator 200, Ultrafeed VA4000, Portafeed VS212	3 Years
150SE, 155SE, 250SE, 400SE, 250TE, 400TE, 180AC/DC, 250AC/DC, 400AC/DC Fabricator 250, Fabricator 330, Fabricator 400, Fabricator 450, 220GMS	2 Years
Options and Accessories	6 Months
Repair and Replacement Parts	3 Months
Torch Consumables	None
Cutting Equipment - Limited Warranty Period	
Product	Period
CutMaster 38, 51, 81, 101, 151	3 Years
PakMaster 150XL, Drag-Gun Plus	2 Years
CutSkill C-35A, C-70A, C-100A, Drag-Gun	1 Year
1TorchTM, SureLokTM Torches and PCH 120	1 Year
Other Torches	6 Months
Repair Parts	3 Months
Arc Accessories - Limited Warranty Period	
Product	Period
All Products	1 Month
Consumables	None
Torch Consumables	None



GLOBAL CUSTOMER SERVICE CONTACT INFORMATION

Thermadyne USA

2800 Airport Road
Denton, Tx 76207 USA
Telephone: (940) 566-2000
800-426-1888
Fax: 800-535-0557
Email: sales@thermalarc.com

Thermadyne Canada

2070 Wyecroft Road
Oakville, Ontario
Canada, L6L5V6
Telephone: (905)-827-1111
Fax: 905-827-3648

Thermadyne Europe

Europe Building
Chorley North Industrial Park
Chorley, Lancashire
England, PR6 7Bx
Telephone: 44-1257-261755
Fax: 44-1257-224800

Thermadyne, China

RM 102A
685 Ding Xi Rd
Chang Ning District
Shanghai, PR, 200052
Telephone: 86-21-69171135
Fax: 86-21-69171139

Thermadyne Asia Sdn Bhd

Lot 151, Jalan Industri 3/5A
Rawang Integrated Industrial Park - Jln Batu Arang
48000 Rawang Selangor Darul Ehsan
West Malaysia
Telephone: 603+ 6092 2988
Fax : 603+ 6092 1085

Cigweld, Australia

71 Gower Street
Preston, Victoria
Australia, 3072
Telephone: 61-3-9474-7400
Fax: 61-3-9474-7510

Thermadyne Italy

OCIM, S.r.L.
Via Benaco, 3
20098 S. Giuliano
Milan, Italy
Tel: (39) 02-98 80320
Fax: (39) 02-98 281773

Thermadyne International

2070 Wyecroft Road
Oakville, Ontario
Canada, L6L5V6
Telephone: (905)-827-9777
Fax: 905-827-9797

World Headquarters

Thermadyne Holdings Corporation
Suite 300, 16052 Swingley Ridge Road
St. Louis, MO 63017
Telephone: (636) 728-3000
Facsimile: (636) 728-3010
Email: sales@thermalarc.com

www.thermalarc.com

