



Operators Manual

Installation, Operation & Service

Gas 25 Gallon Kettle

MODELS:

KGL-25

KGL-25-T



Enodis

1333 East 179th St., Cleveland, Ohio, U.S.A. 44110

Phone: (216) 481-4900 Fax: (216) 481-3782
Visit our web site at www.clevelandrange.com

SE95052

FOR THE USER

IMPORTANT!

ENSURE KETTLE IS AT ROOM TEMPERATURE AND PRESSURE GAUGE IS SHOWING ZERO OR LESS PRESSURE PRIOR TO REMOVING ANY FITTINGS.

FOR YOUR SAFETY

DO NOT STORE OR USE GASOLINE OR ANY OTHER FLAMMABLE LIQUIDS AND VAPOURS IN THE VICINITY OF THIS OR ANY OTHER APPLIANCE.

WARNING: Improper installation, adjustment, alteration, service or maintenance can cause property damage, injury or death. Read the installation operating and maintenance instructions thoroughly before installing or servicing this equipment.

IMPORTANT

POST IN A PROMINENT LOCATION, INSTRUCTIONS TO BE FOLLOWED IN THE EVENT THE USER SMELLS GAS. THIS INFORMATION SHALL BE OBTAINED BY CONSULTING YOUR LOCAL GAS SUPPLIER.

KEEP APPLIANCE AREA FREE AND CLEAR FROM COMBUSTIBLES.

DO NOT OBSTRUCT THE FLOW OF COMBUSTION AND VENTILATION AIR.

ALL SERVICE MUST BE PERFORMED BY A QUALIFIED CLEVELAND RANGE TECHNICIAN.

RETAIN THIS MANUAL FOR YOUR REFERENCE.

TABLE OF CONTENTS

Installation	<i>Inspection</i>	1
	<i>Shipping Damage Instructions</i>	1
	<i>General</i>	1
	<i>Clearance Requirements</i>	1
	<i>Installation</i>	1
	<i>Gas</i>	1
	<i>Electrical</i>	2
	<i>Ventilation</i>	2
	<i>Water</i>	2
	<i>Installation Checks</i>	2
	<i>Cleaning</i>	2
	<i>Specification Drawing</i>	3-4
Operating Instructions	<i>General Parts Drawing</i>	5
	<i>Operating the Kettle</i>	6
	<i>Approximate Boiling Times</i>	6
Cleaning Instructions	<i>Care & Cleaning</i>	7
	<i>Recommended Cleaners</i>	7
Service Parts	<i>Warranty</i>	8
	<i>Faucet Assembly</i>	8
	<i>Component Mounting Plate</i>	9
	<i>Burner Assembly</i>	10
	<i>2" Tangent Draw-Off Valve</i>	11
	<i>General Assembly - Tilting Models</i>	12-14
	- <i>Stationary Models</i>	15-16
	<i>Console Controls</i>	17
	<i>Hinge Assembly</i>	18
Maintenance	<i>Inspection & Maintenance Check List</i>	19
	<i>Safety Inspection Checklist</i>	20-21
	- <i>Safety Valve</i>	20
	- <i>Safety Thermostat</i>	21
	- <i>Low Water Probe</i>	21
	- <i>Operating Thermostat</i>	21
	<i>Lubrication Procedure</i>	22
	<i>Hinge Adjustment Instructions</i>	22
	<i>Calibrating Procedure</i>	23
	<i>Pressure Relief Valve Periodic Testing Procedure</i>	23
	<i>Reservoir Fill Procedures</i>	24
	<i>Kettle Jacket Filling & Draining Procedures</i>	25
	<i>Kettle Venting Instructions</i>	26
	<i>Vacuum Leak Test</i>	26
	<i>Repairing Leaks in Steam Jacketed Kettle Fittings</i>	27
	<i>Wiring Diagram</i>	27
	<i>Sequences of Operation</i>	28-31
	<i>Symbol Legend</i>	32-33

INSTALLATION

INSPECTION

Before unpacking visually inspect the unit for evidence of damage during shipping.

If damage is noticed, do not unpack the unit, follow shipping damage instructions.

SHIPPING DAMAGE INSTRUCTIONS

If shipping damage to the unit is discovered or suspected, observe the following guidelines in preparing a shipping damage claim.

1. Write down a description of the damage or the reason for suspecting damage as soon as it is discovered. This will help in filling out the claim forms later.
2. As soon as damage is discovered or suspected, notify the carrier that delivered the shipment.
3. Arrange for the carrier's representative to examine the damage.
4. Fill out all carrier claims forms and have the examining carrier sign and date each form.

GENERAL

Installation of the kettle must be accomplished by qualified installation personnel working to all applicable local and national codes. Improper installation of product could cause injury or damage.

This equipment is built to comply with applicable standards for manufacturers. Included among those approval agencies are: UL, A.G.A., NSF, ASME/N.Bd., CSA, CGA, ETL, and others. Many local codes exist, and it is the responsibility of the owner/installer to comply with these codes.

Observe all clearance requirements to provide proper make-up air flow. Do not obstruct the flow of combustion and ventilation air. Check rating plate to ensure that kettle has been equipped to operate with the type of gas available at the installation.

Dimensions and clearance specifications are shown on the SPECIFICATION DRAWING (see page #3-4).

CLEARANCE REQUIREMENTS

FOR CLEARANCE REQUIREMENTS (TO COMBUSTIBLE AND NONCOMBUSTIBLE WALLS) AND ASSEMBLY DETAILS REFER TO SPECIFICATION DRAWING ON PAGE #3.

INSTALLATION

Note: For clearance requirements, suggested drain location and assembly details refer to "SPECIFICATION DRAWING" on page #3.

1. Position the unit in its permanent location, and level the unit by turning the adjustable feet.

2. Once positioned and leveled, permanently secure the unit's flanged feet to the floor using 5/16" lag bolts and floor anchors

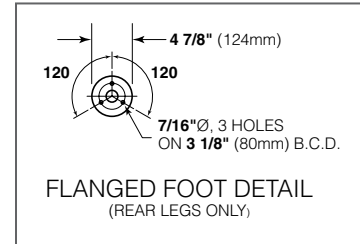

(supplied by the installer). Three bolts are required to secure each of the flanged feet.

3. Seal joints of flanged feet with a silicone sealant.

GAS

ENSURE THE GAS SUPPLY MATCHES THE KETTLE'S REQUIREMENTS AS STATED ON THE RATING PLATE.

It is recommended that a sediment trap (drip leg) be installed in the gas supply line. If the gas pressure exceeds 14" water column, a pressure regulator must be installed, to provide a maximum of 14" water column gas pressure to the gas control valve.

Connect the gas line to the manual valve located at the rear of the control box.

Installation must be in accordance with local codes and/or the National Fuel Gas Code ANSI Z223.1 Latest Edition (USA) or the latest Installation Codes for Gas Burning Appliances and Equipment CAN/ CGA B149.1 and CAN/ CGA B149.2 (Canada). Use a gas pipe joint compound which is resistant to L.P. gas. Test all pipe joints for leaks with soap and water solution. Ensure that the gas pressure regulator is set for the manifold pressure indicated on the gas rating plate.

The appliance and its individual shut-off valve must be disconnected from the gas supply piping system during any pressure testing of that system at test pressures in excess of 1/2 psi (3.45 kPa). The appliance must be isolated from the gas supply piping system by closing its individual manual shut-off valve during any pressure testing of the gas supply piping system at test pressures equal to or less than 1/2 psi (3.45 kPa).

ELECTRICAL

ENSURE THE ELECTRICAL SUPPLY MATCHES THE KETTLE'S REQUIREMENTS AS STATED ON THE RATING LABEL.

A cord and plug are supplied with the unit. Simply plug the unit into any grounded outlet rated for a minimum of 10 amps. See GENERAL ASSEMBLY (pages #12-16) drawings for location of wiring diagram.

WARNING: Electrical Grounding Instructions.

This unit is equipped with a three-prong (grounding) plug for your protection against shock hazard and should be plugged directly into a properly grounded three-prong receptacle. Do not cut or remove the grounding prong from this plug. Standard supply voltage is 115 volts A.C., however, optional A.C. voltages can be supplied on special order. A separate fused disconnect switch must be supplied and installed in the high voltage electrical supply line. The kettle when installed, must be electrically installed and grounded in accordance with local codes, or in the absence of local codes, with National Electrical Code, ANSI/NFPA 70-1990 (USA) or the Canadian Electrical Code, CSA C22.2, Part 1 (Canada).

VENTILATION

Gas fired kettles are only to be installed under a ventilation hood in a room which has provisions for adequate make up air. Further information can be obtained by referring to the U.S.A. National Fire Protection Associations NFPA96 regulations. These standards have also been adopted by the National Building Code in Canada.

WATER

The sealed jacket of the gas-fired kettle is precharged with the correct amount of a water-based formula, and therefore, no water connection is required to the kettle jacket. The kettle can be equipped with optional hot and cold water taps, the taps require 1/2" copper tubing as supply lines.

INSTALLATION CHECKS

Although the kettle has been thoroughly tested before leaving the factory, the installer is responsible for ensuring the proper operation of kettle once installed.

DO NOT ATTEMPT TO OPERATE THIS APPLIANCE DURING A POWER FAILURE.

KEEP APPLIANCE AND AREA FREE AND CLEAR OF COMBUSTIBLES.

1. Before turning the kettle on, read the vacuum/pressure gauge. The gauge's needle should be in the green zone. If the needle is in the "VENT AIR" zone, follow air venting procedure.
2. Supply power to the kettle by placing the fused disconnect switch to the "ON" position.
3. Turn on main gas supply to unit. Open the kettle's shut-off valve (located at back of console).
4. Turn the temperature control knob to "1" (Min.). The green LED light should remain lit, indicating the burner is lit, until the set temperature is reached. Then the green light will cycle on and off, indicating the burner is cycling on and off to maintain temperature.
5. Tilt the kettle forward. The red "LOW WATER" light should be lit when the kettle is in a tilted position. This light indicates that the burner has automatically been shut off by the kettle's safety circuit. This is a normal condition when the kettle is in a tilted position.
6. Raise the kettle to the upright position. The red "LOW WATER" light should go out when the kettle is upright. If the red light remains lit in the upright position, it indicates a low water condition, and water must be added to the reservoir before the kettle can be operated. Refer to the "RESERVOIR FILL PROCEDURES", on page #19.
7. Turn the temperature control knob to "10" (Max.) and allow the kettle to preheat. The green light should remain on until the set temperature is reached. Then the green light will cycle ON and OFF, indicating the burner is cycling ON and OFF to maintain temperature.

CLEANING

After installation the kettle must be thoroughly cleaned and sanitized prior to cooking. See CLEANING INSTRUCTIONS (page #7) for detailed information and suggested cleaners.

SPECIFICATION DRAWING - TILTING MODELS

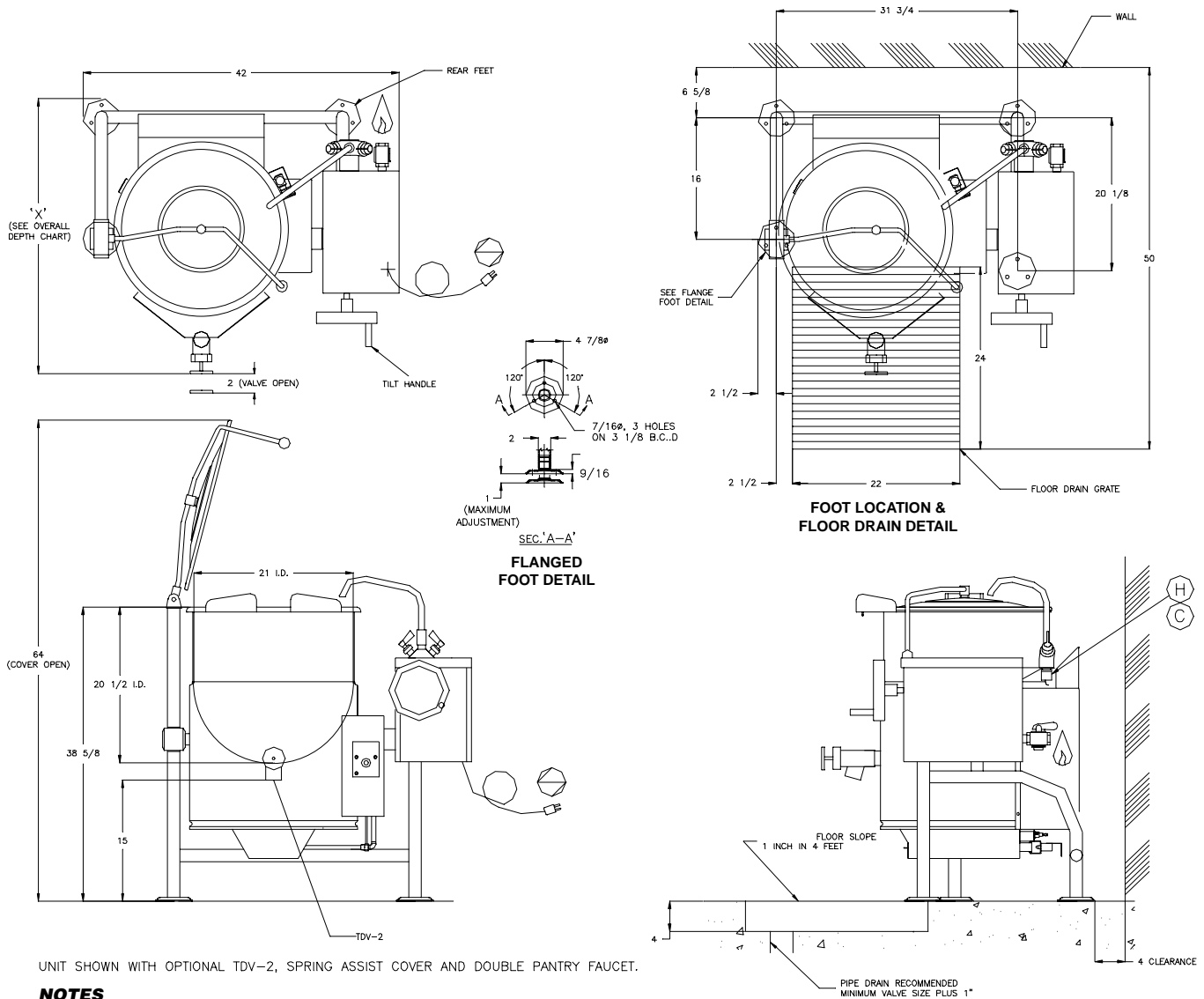

NOTES

1. MANUFACTURER MUST BE NOTIFIED IF UNIT WILL BE OPERATING ABOVE 2,000 FOOT ALTITUDE.
2. CONSULT FACTORY FOR MANUFACTURED GAS.
3. ALL VERTICAL DIMENSIONS SHOWN ARE MINIMUM. FEET ARE ADJUSTABLE TO 1 INCH MAXIMUM.
4. UNIT COMES WITH 6' POWER CORD.

SPECIFICATIONS

MODEL	ELECTRICAL SUPPLY:				GAS SUPPLY: (PIPING 3/4 NPT)				APPROVALS				CLEARANCE:	SHIPPING WEIGHT
	VOLTS	PHASE	AMPS	FREQ	TYPE	BTU RATING	WATER COLUMN	BTU PER CU. FT.	SUPPLY PRESSURE	AGA	CGA	CE MARK		
KGL-25-T	120	1	5	60	NAT	90,000	4.2	1000	4" TO 14" W.C.	✓	✓	✓	✓	320 LBS.
	120	1	5	60	LP	90,000	10	2500	4" TO 14" W.C.	✓	✓	✓	✓	
	220	1	3	60	NAT	90,000	4.2	1000	4" TO 14" W.C.				✓	
	220	1	3	60	LP	90,000	10	2500	4" TO 14" W.C.				✓	

RIGHT: 0 inches
LEFT: 0 inches
REAR: 4 inches
ALLOW 12" SPACE MINIMUM ON RIGHT SIDE FOR SERVICE

OVERALL DEPTH

DESCRIPTION	DIM 'X'
KETTLE WITH TDV-2	37
KETTLE WITHOUT TDV-2 TILT HANDLE ON	32 1/2
FOR PASSING THROUGH NARROW DOORS	
* KETTLE WITH TDV-2 STEM & REAR FEET REMOVED	32 1/2
* KETTLE WITHOUT TDV-2	31 1/2
* KETTLE WITHOUT TDV-2 & REAR FEET REMOVED	30

* TILT HANDLE REMOVED

OPERATING INSTRUCTIONS



General Parts Drawing

ITEM #	DESCRIPTION	FUNCTION
1.	Tilt Wheel (tilting models only)	Used for tilting the kettle.
2.	Vacuum/Pressure Gauge	Indicate steam pressure in PSI inside steam jacket as well as vacuum in inches of mercury.
3.	Pressure Relief Valve	This valve is used to vent the kettle and in the unlikely event there is an excess steam build-up in the jacket, this valve opens automatically to relieve this pressure.
4.	Low Water Indicator Light (Red)	When lit, indicates that the kettle is low on water and will not operate in this condition (see RESERVOIR FILL PROCEDURES on page #24).
5.	On-Off Switch/ Solid State Temperature Control	Turns kettle ON/OFF and allows the operator to adjust the kettle temperature in increments from 1 (Min.) to 10 (Max.). (see TEMPERATURE RANGE CHART on page #6).
6.	Heat Indicator Light (Green)	When lit, indicates that the kettle's burner is on. Cycles ON-OFF with burner.
7.	Water Level Sight Glass	Displays water level in steam jacket.
8.	Ignition Failure Indicator Light (Amber)	Indicates failure of heating system to ignite.
9.	Tangent Draw-Off Valve	Used for draining product or wash water from kettle. It is supplied as standard equipment on stationary kettles and is optional on tilting kettles.

OPERATING THE KETTLE

DO NOT ATTEMPT TO OPERATE THIS APPLIANCE DURING A POWER FAILURE.

KEEP APPLIANCE AND AREA FREE AND CLEAR OF COMBUSTIBLES.

DO NOT LEAN ON OR PLACE OBJECTS ON KETTLE LIP. SERIOUS INJURY COULD RESULT IF KETTLE TIPPED OVER, SPILLING HOT CONTENTS.

1. Before turning kettle on, read the Vacuum/Pressure Gauge (2). The gauges needle should be in the green zone. If the needle is in the "VENT AIR" zone, refer to the Kettle Venting Instructions (page #21). Any air that may be present will increase cooking times. Once heated, the kettle's normal maximum operating pressure is approximately 10-12 psi while cooking a water base product.
2. Ensure that the electrical service to the kettle is turned on at the fused disconnect switch.

Temperature Control Setting	Approximate Product Temperature	
	°F	°C
MIN.	120	49
1.	130	54
2.	145	63
3.	160	71
4.	170	77
5.	185	85
6.	195	91
7.	210	99
8.	230	110
9.	245	118
MAX.	265	130

NOTE: Certain combinations of ingredients will result in temperature variations

Temperature Range Chart

3. Preheat the kettle by turning the ON/OFF Switch/Solid State Temperature Control (5) to the desired temperature setting (see above, TEMPERATURE RANGE CHART). The Heat Indicator Light (Green) (6) will remain lit, indicating the burner is on, until the temperature setting is reached. When the green light goes off, the burners are off, and preheating is complete.

NOTE: When cooking egg and milk products, the kettle should not be preheated, as products of this nature adhere to hot cooking surfaces. These types of food should be placed in the kettle before heating is begun.

4. Place food product into the kettle. The Heat Indicator Light (Green) (6) will cycle on and off indicating the burners are cycling on and off to maintain the set temperature.

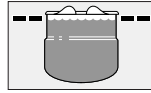

NOTE: Do not fill kettle above recommended level marked on outside of kettle.

NOTE: The Low Water Indicator Light (Red) (4) should not be lit during kettle operation. This light indicates that the burners have been automatically shut off by the kettle's safety circuit. It is normal for the red light to come on when the kettle is in a tilted position. However, the kettle cannot be operated when the red light remains lit while the kettle is in the upright position. This indicates a low water condition, and water must be added to the reservoir. Refer to Reservoir Fill Procedures on page #19 of this manual for details.

5. When cooking is completed turn ON/OFF Switch/Solid State Temperature Control (5) to the "OFF" position.

NOTE: A five minute complete shut-of period is required before relighting.

6. Pour the contents of the kettle into an appropriate container by tilting the kettle forward. Care should be taken to pour slowly enough to avoid splashing off the product.

NOTE: As with cleaning food soil from any cookware, an important part of kettle cleaning is to prevent food from drying on. For this reason, cleaning should be completed immediately after cooked foods are removed. Refer to the Cleaning Instructions (page #6) for detailed kettle washing procedures.

APPROXIMATE BOILING TIMES

The accompanying chart shows approximate times required for electric kettles of various capacities to boil water. The ON/OFF Switch/Solid State Temperature Control (5) must be set at "10" (Max.) throughout the heat-up period. Water will boil about 1/3 faster if the kettle is filled only to the outer steam jacket's welded seam resulting in a kettle filled to 2/3 capacity.

Kettle Capacity	Minutes
25 gallon	37

Approximate Boiling Times

CLEANING INSTRUCTIONS

CARE AND CLEANING

Your kettle must be cleaned regularly to maintain its fast, efficient cooking performance, and to ensure its continued safe, reliable operation.



Chloride Cleaners

WARNING: Do not use chloride base detergents. There is a growing number of non-chloride cleaners available. If unsure of the cleaners chlorine content consult the supplier. Also avoid cleaners containing quaternary salt as they can cause the stainless steel to pit and rust.

WARNING: If any gaskets or seals are found defective, replace or repair immediately. (See Service Parts Drawings for part identification.)

1. Place the kettle's On-Off Switch/Solid State Temperature Control (5) to the "OFF" position.
2. Prepare a warm water and mild detergent solution in the kettle.
3. Remove food soil inside the kettle using a nylon brush.



Wire Brush & Scrapers

WARNING: Do not use a metal bristle brush or scraper, as this may permanently damage the kettle's stainless steel surface.

4. Loosen food which is stuck to the kettle by allowing it to soak at a low temperature setting.
5. If the kettle is equipped with a draw-off valve, it should be cleaned as follows:
 - a) Remove drain screen from bottom of kettle. Thoroughly wash and rinse the screen either in a sink or a dishwasher, then replace it into the kettle.
 - b) Disassemble the draw-off valve first by turning the valve knob counter-clockwise, then turning the large hex nut counter-clockwise until the valve stem is free of the valve body.

- c) In a sink, wash and rinse the inside of the valve body using a nylon brush.
- d) Reassemble the draw-off valve by reversing the procedure for disassembly. The valve's hex nut should be hand tight only.

6. Rinse kettle interior thoroughly, then drain the rinse water. Do not leave water sitting in unit when not in use.

7. Using mild soapy water and a damp sponge, wash the exterior of the kettle, rinse, and dry.

NOTE: For more difficult cleaning applications one of the following can be used: alcohol, baking soda, vinegar, or a solution of ammonia in water.

Avoid the use of chloride cleansers, which may damage the kettle's stainless steel surface.



Steel Pads

WARNING: Steel wool should never be used for cleaning the cooking chamber of the kettle. Particles of steel wool become embedded in the cooking surface and rust, which may corrode the stainless steel.

NOTE: Unit should not be cleaned with a water jet.

8. Leave the cover off when the kettle is not in use.

RECOMMENDED CLEANERS FOR SPECIFIC SITUATIONS

Job	Cleaning Agent	Comments
Routine Cleaning	Soap, Ammonia Detergent, Medallion	Apply with cloth or sponge
Fingerprints & Smears	Arcal 20, Lac-O-Nu Ecoshine	Provides barrier film
Stubborn Stains & Discolouration	Cameo, Talc, Zud First Impression	Rub in direction of polish lines
Grease & Fatty Acids, Blood, Burnt-On Foods	Easy-Off, De-Grease It Oven Aid	Excellent removal on all finishes
Grease & Oil	Any good commercial detergent	Apply with sponge or cloth
Restoration/Passivation	Benefit, Super Sheen	

SERVICE PARTS

WARRANTY

Our Company supports a worldwide network of Maintenance and Repair Centers. Contact your nearest Maintenance and Repair Centre for replacement parts, service, or information regarding the proper maintenance and repair of your cooking equipment

In order to preserve the various agency safety certification (UL, NSF, ASME/Ntl. Bd., etc.), only factory-supplied replacement parts should be used. The use of other than factory supplied replacement parts will void warranty.

FAUCET ASSEMBLY (optional)

ITEM NO.	PART NO.	DESCRIPTION	QTY.
1.		<u>3/4" SPOUT</u>	
	KE50825-7	FOR STATIONARY KETTLES	1
	KE50825-2	FOR TILTING KETTLES	1
2.	FA95022	RETAINING RING	1
3.	FA05002-19	"O" RING	1
4.	KE51736	LONG FAUCET NUT	1
5.	SE50020	HOT WATER STEM ASSEMBLY	1
		(DOUBLE PANTRY ONLY)	
6.	SE50021	COLD WATER STEM ASSEMBLY	1
7.	KE51401	SINGLE PANTRY BODY	1
		(C/W ITEM NO. 6)	
8.	KE50335	ADAPTER WASHER	1
		(SINGLE PANTRY ONLY)	
9.	KE51403	DOUBLE PANTRY BODY	1
		(C/W ITEM NO. 5&6)	
10.	SK00395-1	FAUCET MOUNTING BRACKET	1
11.	FA11258	HEX CAP SCREW	2
12.	FA30505-1	WASHER	2
13.	FA21008	HEX NUT	2
14.	SE50447	WASHER HORSESHOE	1

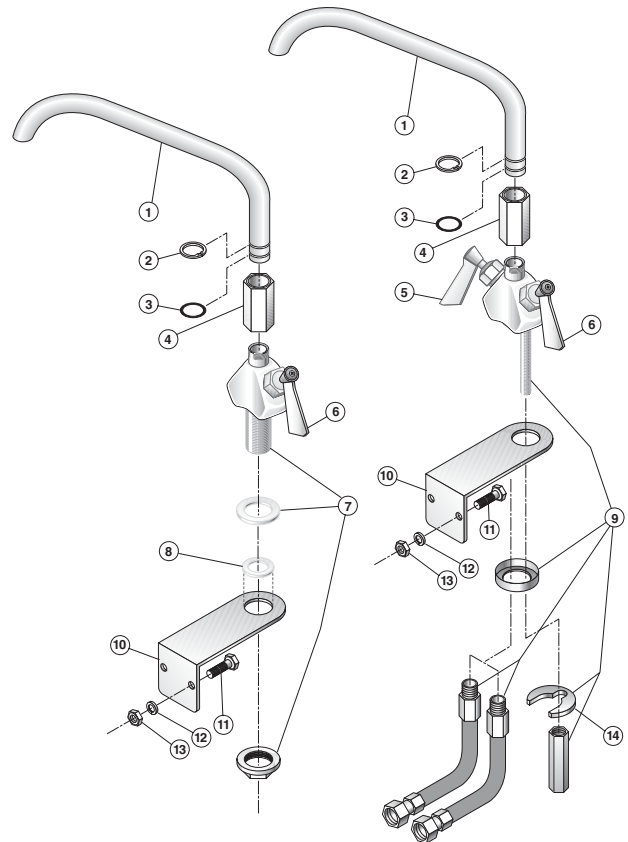

COMPONENT MOUNTING PLATES

STATIONARY MODELS

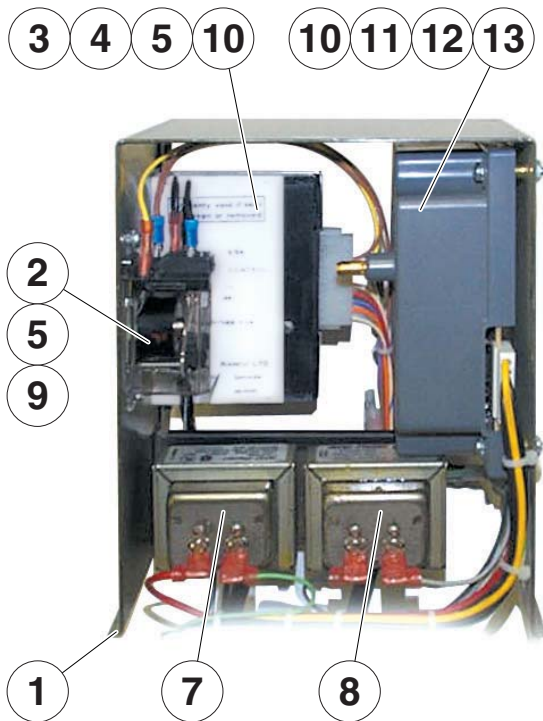

TILTING MODELS

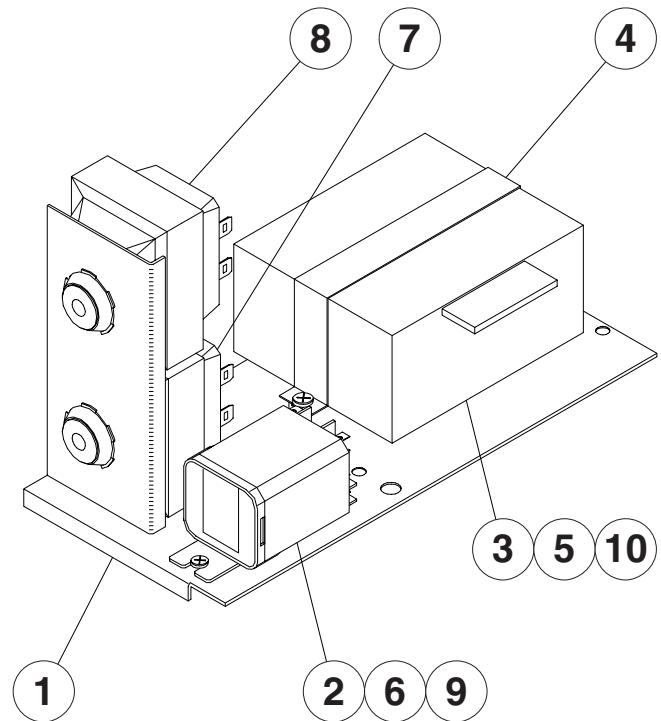

ITEM NO.	PART NO.	DESCRIPTION	QTY.
1.	KE01927-1	COMPONENT MOUNTING PLATE (STATIONARY MODELS)	1
	KE01927	COMPONENT MOUNTING PLATE (TILTING MODELS)	1
2.	KE50753-7	RELAY	1
3.	KE00458	SSK CONTROL BOX	1
4.	KE50303	ELECTRONIC BOX HOLDER (STATIONARY MODELS)	1
	KE52548	ELECTRONIC BOX HOLDER (TILTING MODELS)	1
5.	FA11089	SCREWS	2
6.	FA11052	SCREWS	2
9.	FA32004	TOOTH LOCKWASHER	2
10.	FA32005	TOOTH LOCKWASHER	6
11.*	KE53469-2	IGNITION CONTROL	1
12.*	FA10245	SCREW (8-32)	4
13.*	FA20004	HEX NUT	4
FOR 120V OPTION			
7.	KE53838-20	TRANSFORMER	1
8.	KE53838-27	TRANSFORMER	1
FOR 240V OPTION			
7.	KE53838-18	TRANSFORMER	1
8.	KE53838-21	TRANSFORMER	1

* LOCATED IN GEARBOX ON GAS MODELS

BURNER ASSEMBLY

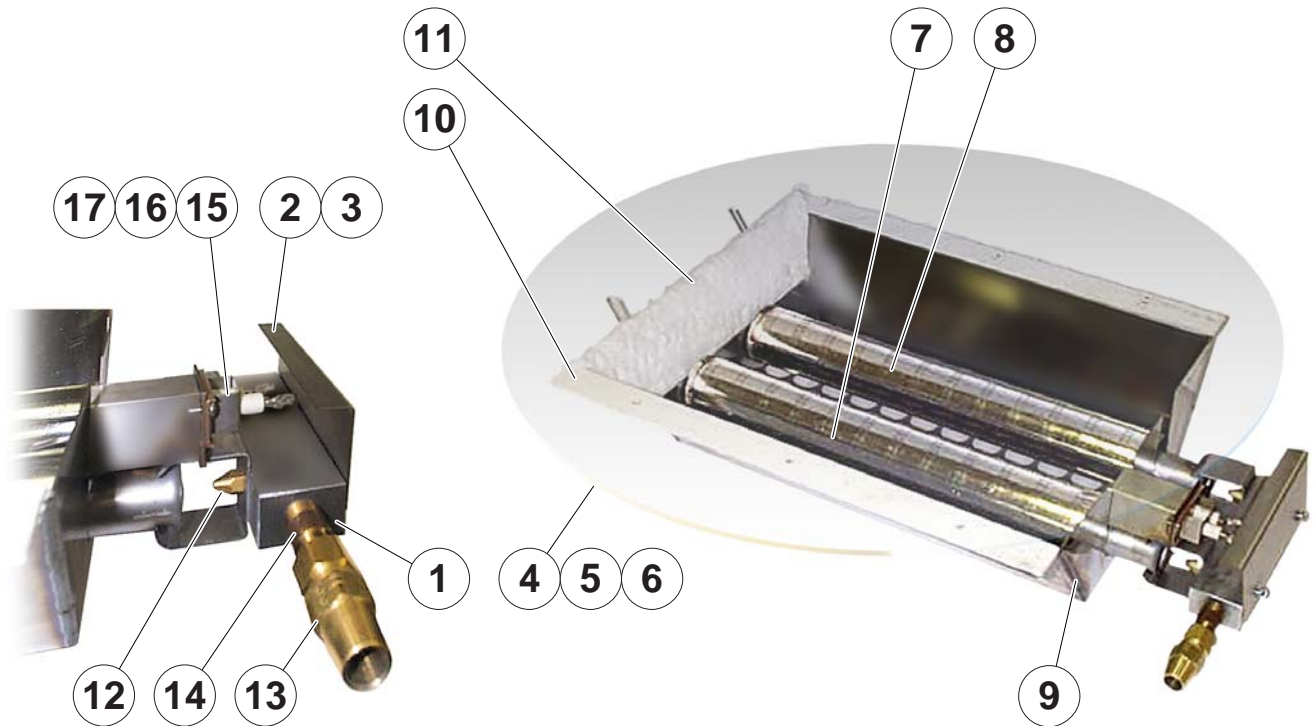

ITEM NO.	PART NO.	DESCRIPTION	QTY.
1.	KE54897-1	MANIFOLD	1
2.	KE54890-1	IGNITION GUARD	1
3.	FA11144	SCREW	2
4.	KE54881-1	BOTTOM COVER	1
5.	KE54894-1	HOLDER, BOTTOM COVER	1
6.	KE54895-3	INSULATION ON TOP OF COVER	1
7.	KE01500-2	BURNER ASSEMBLY	1
8.	KE01500-4	BURNER WITHOUT IGNITOR	1
9.	KE02195-1	BURNER PAN ASSEMBLY	1
10.	KE54895-2	INSULATION BETWEEN BOTTOM COVER & BURNER ASSEMBLY	2
11.	KE54895-4	INSULATION	1
12.	KE53406-21	GAS ORIFICE, NATURAL GAS	2
	KE53406-18	GAS ORIFICE, LP.	2
13.	FI05134-1	COMPRESSION FITTING	2
14.	FI00565-6	NIPPLE 3/8 NPT	1
15.	KE53437-1	IGNITOR	1
16.	FA11145	SCREW	2
17.	KE54775	IGNITOR POSITION HOLDING BRACKET	1

2" TANGENT DRAW-OFF VALVE

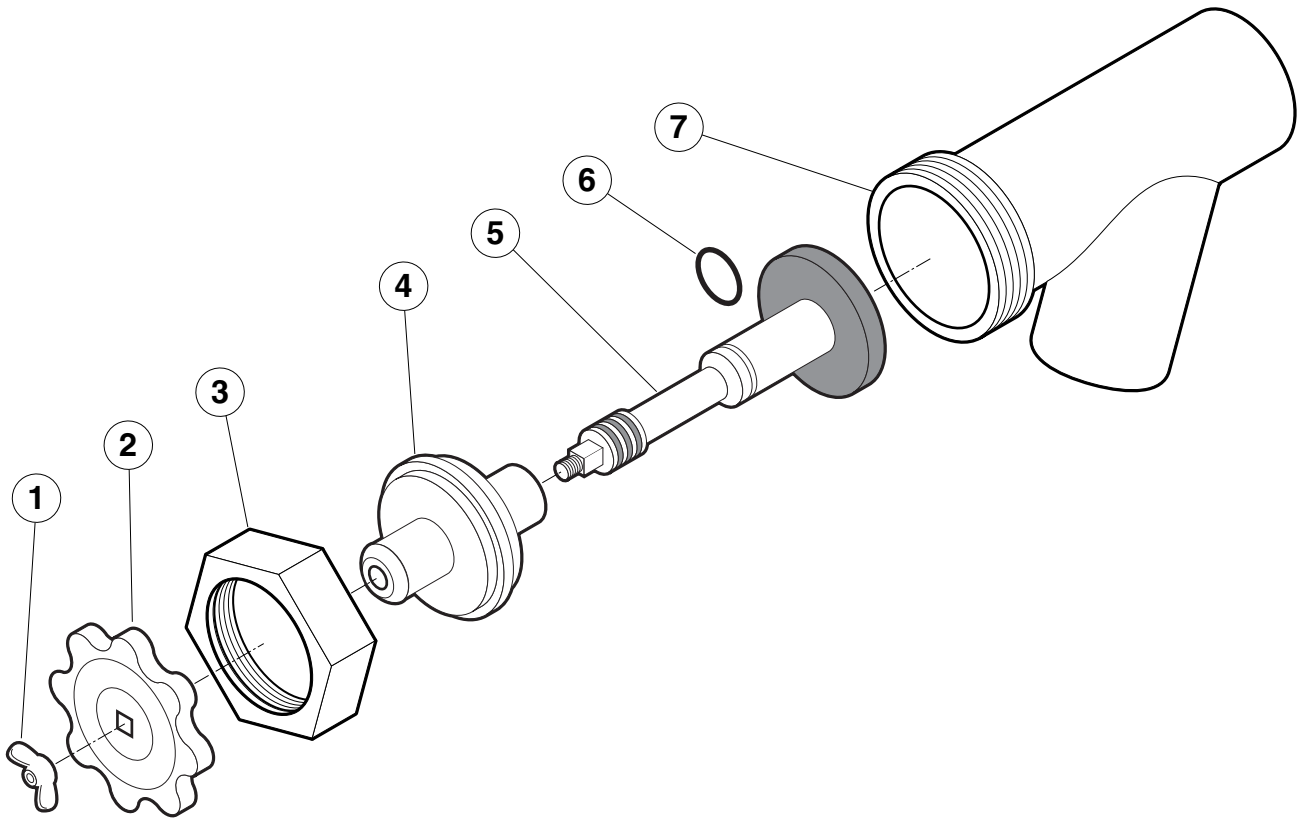

ITEM NO.	PART NO.	DESCRIPTION	QTY.
1. - 7.	KE50972-B	DRAW-OFF ASSEMBLY	1
1.	FA95049	WING NUT	1
2.	KE527551	KNOB	1
3.	KE52754	HEX NUT	1
4.	KE52753	RETAINER	1
5.	KE52752	PISTON	1
6.	FA00111	"O" RING	1
7.	KE52751	VALVE BODY	2

GENERAL ASSEMBLY - TILTING MODELS (pg. 1 of 3)

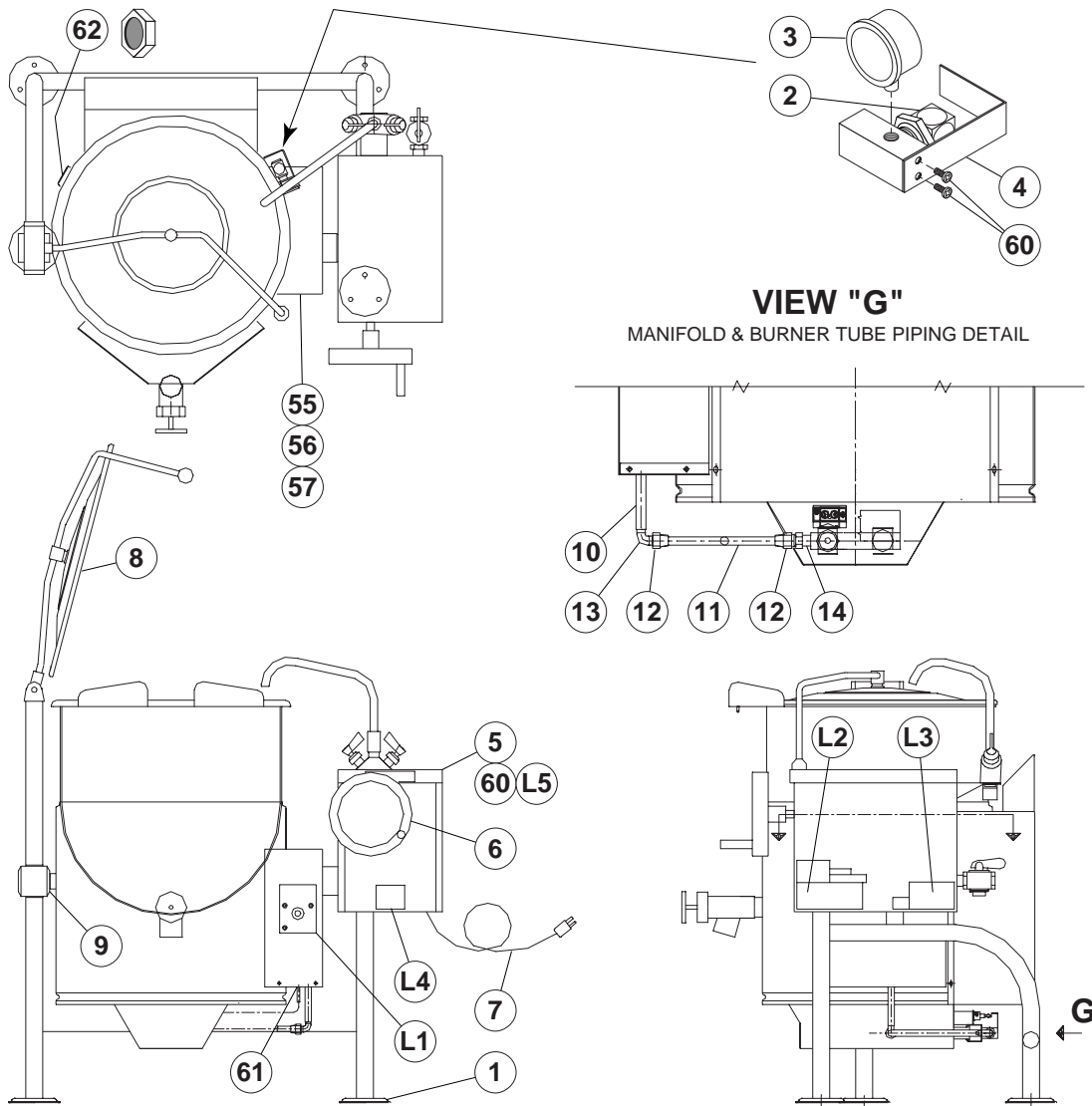

ITEM NO.	PART NO.	DESCRIPTION	QTY.
1.	KE00099	ADJUSTABLE FOOT	1
2.	KE51723-1	SAFETY VALVE (50 PSI)	1
3.	KE50429-3	PRESSURE GAUGE	1
4.	KE54852-1	BRACKET FOR SAFETY VALVE	1
5.	KE529773	LID FOR GEAR BOX	1
6.	KE00508	HANDWHEEL	1
7.	KE54821-8	SUPPLY CORD	1
8.	CHS-KGL-25-T	SPRING HINGE COVER	1
9.	KE00351	TRUNNION BEARING	1
10.	FI05321-1	NIPPLE	1
11.	KE54667-3	BURNER TUBE	1
12.	FI05134-1	COMPRESSION FITTING	2

GENERAL ASSEMBLY - TILTING MODELS (pg. 2 of 3)

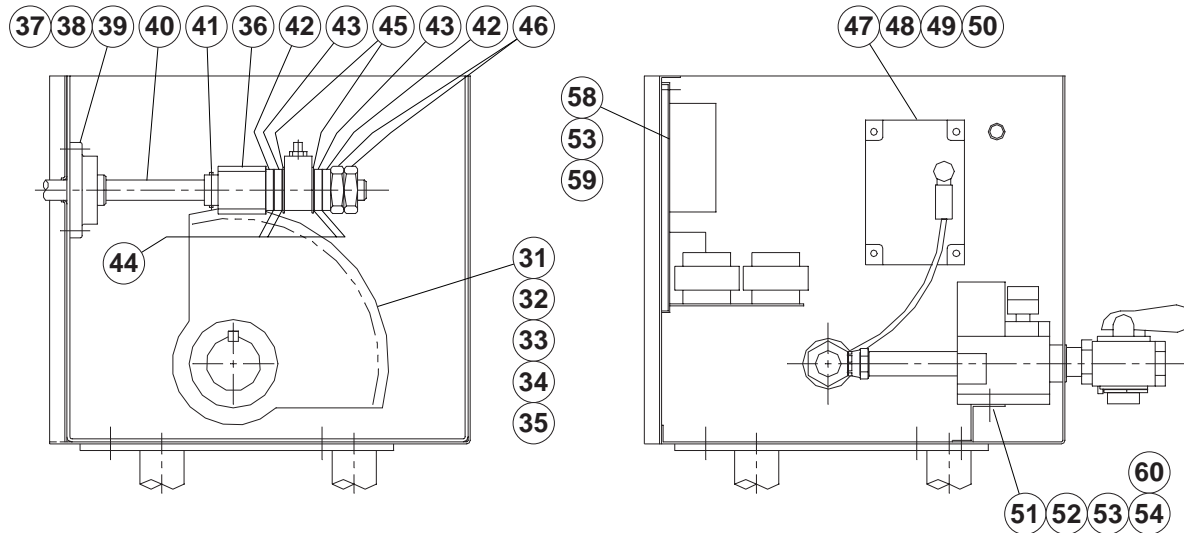
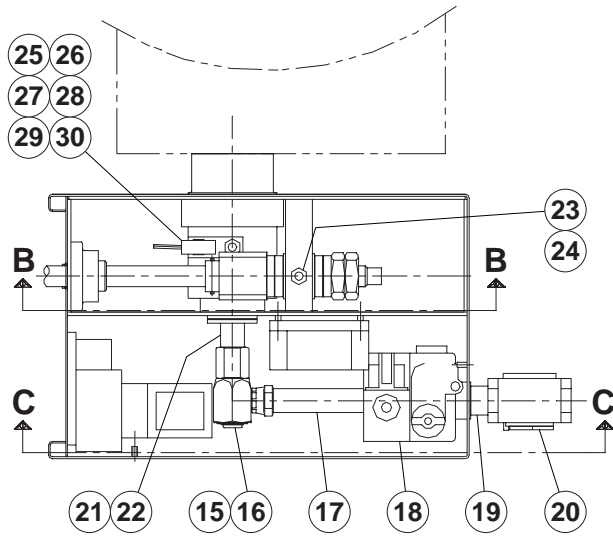

13.	FI05198-5	COMPRESSION ELBOW1
14.	FI00565-6	NIPPLE 3/8 NPT1
15.	FI05222	SWIVEL ELBOW1
16.	FI05231	FLUSH BUSHING1
17.	FI05223	SPECIAL NIPPLE1
18.	KE02053	GAS VALVE ASSEMBLY1
19.	FI00607	CLOSE NIPPLE1
20.	F01518-1	GAS SHUT OFF VALVE1
	<i>GAS OPTIONS:</i>		
	KE54618-1	PRESSURE REGULATOR (PROPANE)1
	KE54618-2	PRESSURE REGULATOR (NATURAL GAS)1
21.	F105226-12	NIPPLE1
22.	FI00040	ELBOW1

GENERAL ASSEMBLY - TILTING MODELS (pg. 3 of 3)

23.	FA19177	HEX SOCKET SET SCREW	1
24.	FA20047	JAM NUT	1
25.	KE50294-1	MERCURY SWITCH	1
26.	KE54456-1	MERCURY SWITCH BRACKET	1
27.	KE50295-1	CLIP FOR MERCURY SWITCH	
28.	FA11396	HEX HEAD BOLT (3/8-24)	1
29.	FA31031	SPLIT LOCK WASHER	1
30.	FA15018-7	SCREW 6-32	1
31.	KE52833	WORM GEAR	1
32.	FA10772	SOCKET HEAD CAP SCREW	2
33.	FA20030	JAM NUT	2
34.	FA95007-4	RETAINING RING	1
35.	FA95055-1	SQUARE KEY	1
36.	KE50315	WORM	1
37.	KE51730	TILT SHAFT BEARING	1
38.	FA31010	SPLIT LOCK WASHER	2
39.	FA20030	HEX NUT	2
40.	KE503752	TILT SHAFT	1
41.	FA95005	TENSION PIN	1
42.	KE52193	THRUST BEARING SPACER	2
43.	KE52191	ROLLER BEARING	2
44.	KE52192	THRUST WASHER	4
45.	FA30088	WASHER	2
46.	FA95008	JAM NUT	2
47.	KE53469-2	IGNITION CONTROL	1
48.	FA10245	SCREW (8-32)	4
49.	FA20004	HEX NUT	4
50.	FA32005	TOOTH LOCKWASHER	4
51.	KE53390	GAS VALVE MOUNTING BRACKET	1
52.	FA10367	BINDING HEAD SCREW (10-32)	2
53.	FA32006	TOOTH LOCKWASHER (J10)	2
54.	FA20007	MACHINE SCREW NUT (10-32)	2
55.	KE53316	SAFETY THERMOSTAT	1
56.	KE00515	THERMISTOR ASSEMBLY	1
57.	KE50556-1	LOW WATER PROBE	1
58.	KE01928-1	COMPONENT MOUNTING PLATE ASSEMBLY (see COMPONENT MOUNTING PLATES on page #9)	1
59.	FA20006	MACHINE SCREW NUT (10-24)	2
60.	FA11145	SCREWS	6
61.	KE54833-2	SNAP-IN BUSHING	1
62.	KE54468	WATER LEVEL SIGHT GLASS	1
<i>LABELS</i>			
L1.	KE95555-5	OPERATING INSTRUCTION LABEL	1
L2.	KE95552	RATING PLATE	1
L3.	KE95551	GAS KETTLE LABEL GENERAL	1
L4.	KE95040	DIRECTION OF TILT LABEL	1
L5.	KE90424	WIRING DIAGRAM	1

GENERAL ASSEMBLY - STATIONARY MODELS (pg. 1 of 2)

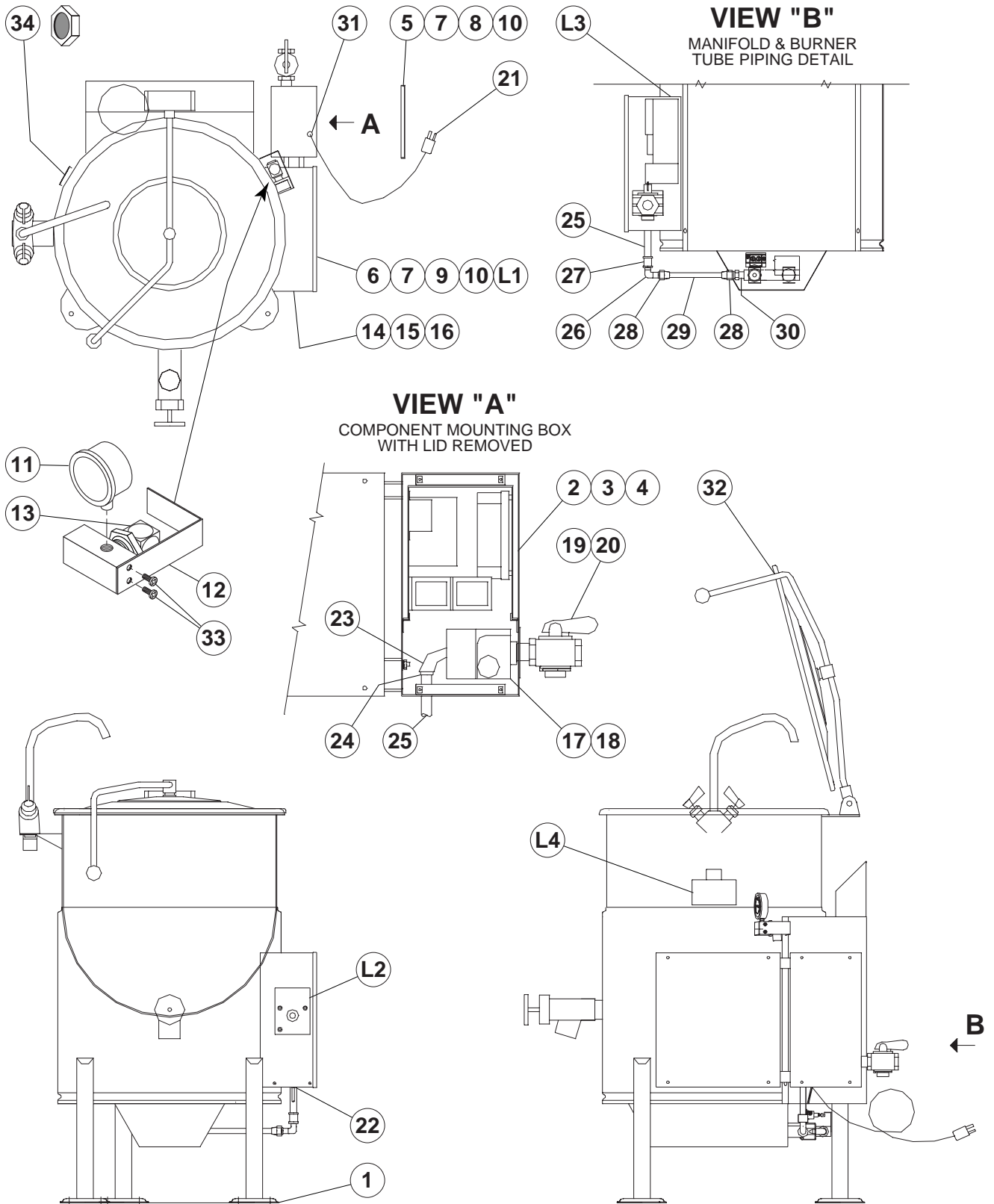

GENERAL ASSEMBLY - TILTING MODELS (pg. 2 of 2)

ITEM NO.	PART NO.	DESCRIPTION	QTY.
1.	KE00099	ADJUSTABLE FOOT	3
2.	KE01928-2	COMPONENT MOUNTING PLATE ASSEMBLY (see COMPONENT MOUNTING PLATES on page #9)	1
3.	FA20006	MACHINE SCREW NUT (10-24)	1
4.	FA32006	TOOTH LOCK WASHER	1
5.	KE54991-1	LID (COMPONENT BOX)	1
6.	KE54991-2	LID (SIDE BOX)	1
7.	FA95074	ANCHOR NUT	8
8.	KE54846-4	GASKET (COMPONENT BOX LID)	1
9.	KE54846-5	GASKET (SIDEBOX LID)	1
10.	FA95031	PAN HEAD PHILLIPS DRIVE SCREW	8
11.	KE50429-3	PRESSURE GAUGE	1
12.	KE54852-1	BRACKET FOR SAFETY VALVE	1
13.	KE54941-6	SAFETY VALVE (50 PSI)	1
14.	KE53316	SAFETY THERMOSTAT	1
15.	KE00515	THERMISTOR ASSEMBLY	1
16.	KE50556-1	LOW WATER PROBE	1
17.	KE02053	GAS VALVE ASSEMBLY	1
18.	FA10360	SCREW PAN HEAD PHILLIPS (10-32)	2
19.	F01518-1	GAS SHUT OFF VALVE (OPTION)	1
		<i>GAS OPTIONS:</i>	
	KE54618-1	PRESSURE REGULATOR (PROPANE)	1
	KE54618-2	PRESSURE REGULATOR (NATURAL GAS)	1
20.	FI00607	CLOSE NIPPLE	1
21.	KE54821-8	SUPPLY CORD (OPTION)	1
22.	KE54833-2	SNAP IN BUSHING	1
23.	FA00152	STREET ELBOW (3/4)	1
24.	FI00355	BUSHING (3/4 X 3/8)	1
25.	FI00565-3	NIPPLE (3/8)	1
26.	FI05198-5	COMPRESSION ELBOW	1
27.	FI00265	COUPLING (3/8)	1
28.	FI05134-1	COMPRESSION FITTING	2
29.	KE54667-4	BURNER TUBE	1
30.	FI00565-6	NIPPLE (3/8 NPT)	1
31.	KE51238	CORD CONNECTOR	1
32.	CHS-25	SPRING HINGE COVER	1
33.	FA11145	SCREWS	2
34.	KE54468	WATER LEVEL SIGHT GLASS	1
		<i>LABELS</i>	
L1.	KE90424	WIRING DIAGRAM	1
L2.	KE95555-5	OPERATING INSTRUCTION LABEL	1
L3.	KE95552	RATING PLATE	1
L4.	KE95551	LABEL SHEET	1

CONSOLE CONTROLS

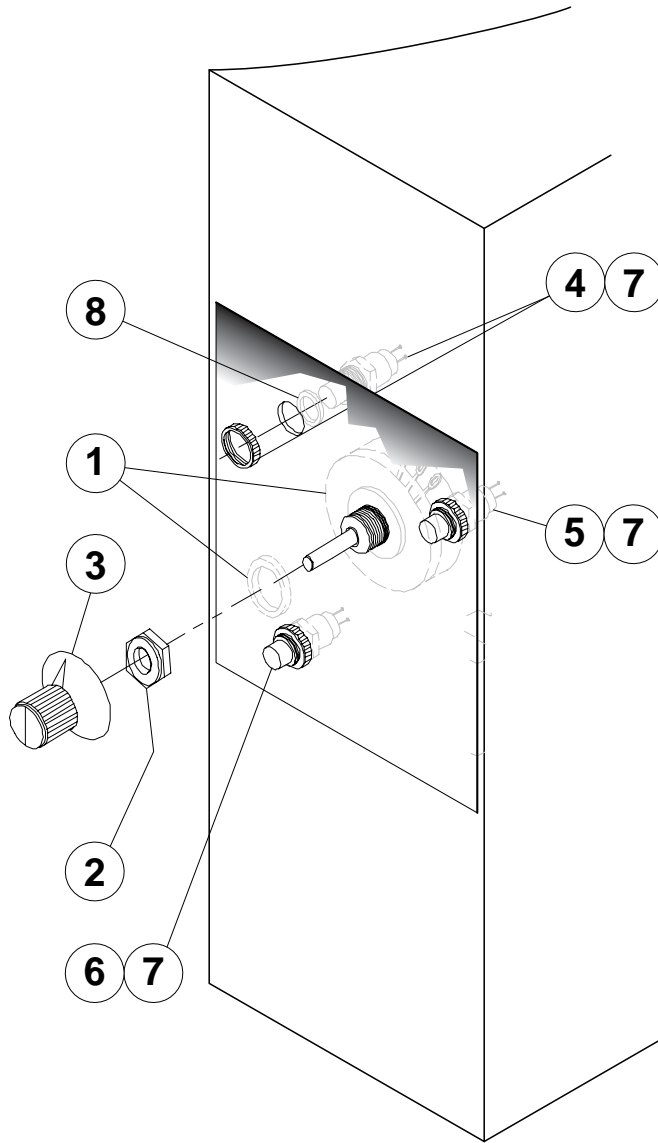

ITEM NO.	PART NO.	DESCRIPTION	QTY.
1.	SE00114	POTENTIOMETER WITH ON/OFF SWITCH, C/W ITEM #2	1
2.	KE51005	RUBBER BOOT	1
3.	KE50569-1	KNOB, POTENTIOMETER	1
4.	KE50567-1	L.E.D., RED	1
5.	KE50568-1	L.E.D., GREEN	1
6.	KE50567-2	L.E.D., AMBER	1
7.	FA05002-18	"O" RING	3

HINGE ASSEMBLY

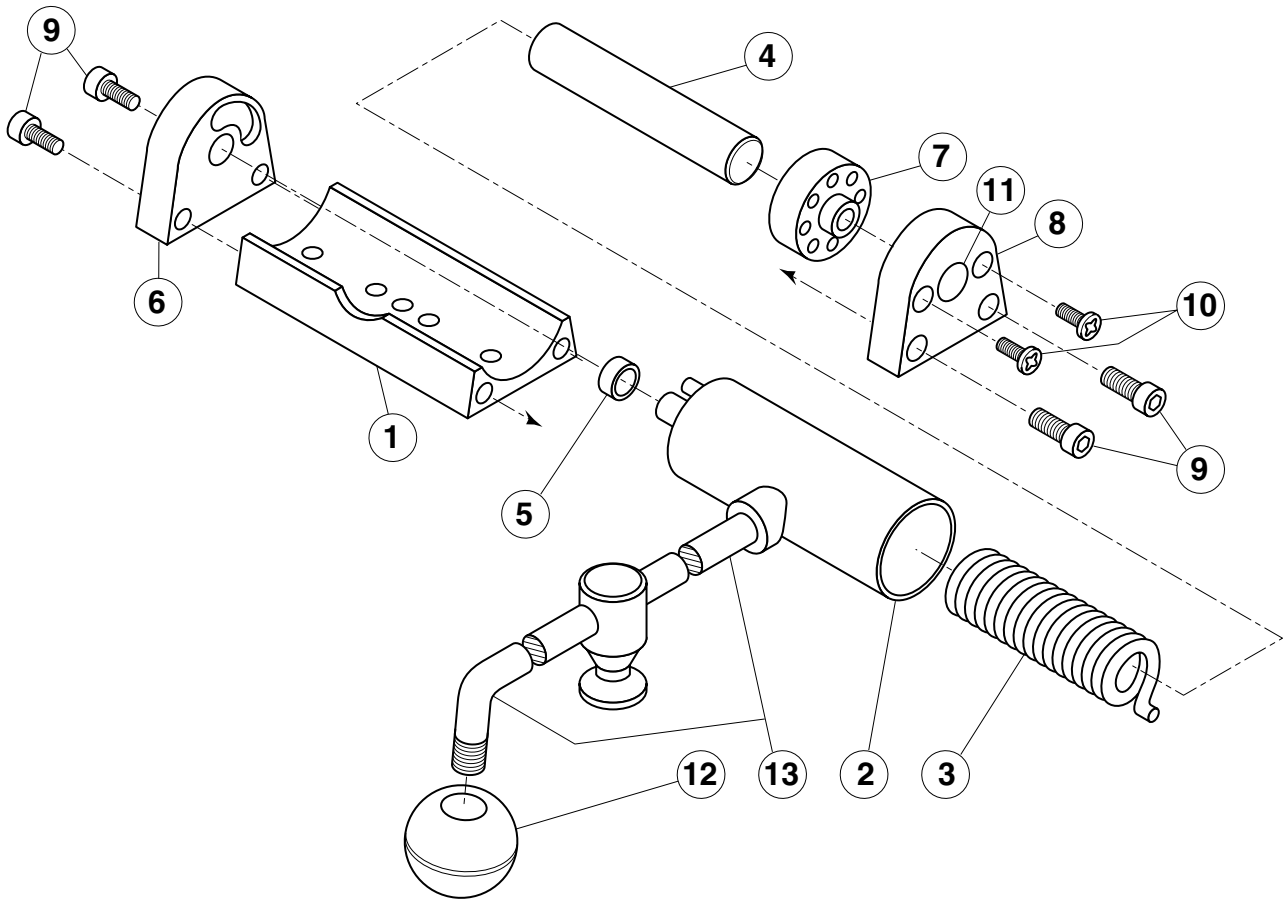

ITEM NO.	PART NO.	DESCRIPTION	QTY.
1. - 11	SE00120-1	Hinge Assembly	1
1.	KE50882	Hinge Base	1
2.	KE51217	Hinge Cylinder	1
3.	KE50121-2	Hinge Spring	1
4.	KE50823-1	Hinge Pin	1
5.	KE50824	Hinge Bearing	1
6.	KE50819-1	Hinge End Piece, LHS	1
7.	KE50820	Hinge Insert	1
8.	KE50819	Hinge End Piece, RHS	1
9.	FA11284	Screw, Socket Head, 1/4-20 x 1/2	4
10.	FA11507	Cutting Screw,	2
11.	KE54907-10	Plug Button	1
12.	KE50151-12	Knob	1
13.		Cover Handle (specify model)	1

MAINTENANCE

ALL SERVICE MUST BE PERFORMED BY A QUALIFIED SERVICE TECHNICIAN.

IMPORTANT!
**ENSURE KETTLE IS AT ROOM TEMPERATURE AND
PRESSURE GAUGE IS SHOWING ZERO OR LESS PRESSURE
PRIOR TO REMOVING ANY FITTINGS.**

Cleveland Range equipment requires little preventative maintenance. We do however provide the following chart as a guideline for inspection and maintenance to keep your unit functioning at 100%.

INSPECTION AND MAINTENANCE CHECKLIST

The following check should be completed every six months or more frequently if unit is in a high volume facility.

WARNING: It is imperative that damaged seals be repaired immediately to prevent equipment failure and/or damage.

ITEM	CHECK
HAND WHEEL (tilting models only)	Check hand wheel for tightness. If loose tighten allen screw.
LUBRICATION (tilting models only)	Check that kettle tilts smoothly. Grease trunnion housings and gear/worm assembly every three months as recommended in LUBRICATION PROCEDURE on page #22.
GEAR/WORM	Inspect for play. Tighten Allen screws if required.
PRESSURE GAUGE	Check that the gauge does not have moisture on its inside face. Replace if moisture is present. Check that the gauge shows a vacuum (needle is well into the Green zone) when cold and shows between 25-40 psi when unit is hot. If not follow VACUUM LEAK TEST on page #26.
PRESSURE RELIEF VALVE	Check pressure relief valve as described in PRESSURE RELIEF VALVE TESTING PROCEDURE on page #22.
TEMPERATURE CHECK	Following the CALIBRATING PROCEDURE on page #23, check the inner kettle surface temperature with a digital surface thermometer and adjust if required.
ON/OFF SWITCH/ TEMPERATURE CONTROL	Check for damage. Replace if necessary.
SPRING ASSIST COVER	Check cover is tightly secured to handle and insure spring is holding cover up - adjust if required. Refer to HINGE ADJUSTMENT INSTRUCTIONS on page #22.

SAFETY INSPECTION CHECKLIST-

TILTING MODELS (pg. 1 of 2)

Regular inspection and maintenance of units is essential to obtain trouble free and safe operation of equipment. Inspections must include testing of the pressure relief valve and checks of the operating system to insure that it has not been altered.

No safety features designed into the equipment should ever be tampered with.

Tampering with or bypassing controls is a very dangerous practice and unfortunately we have seen several cases of this. Following is a short list of the most common and the most dangerous alterations performed on kettles.

SAFETY VALVE:

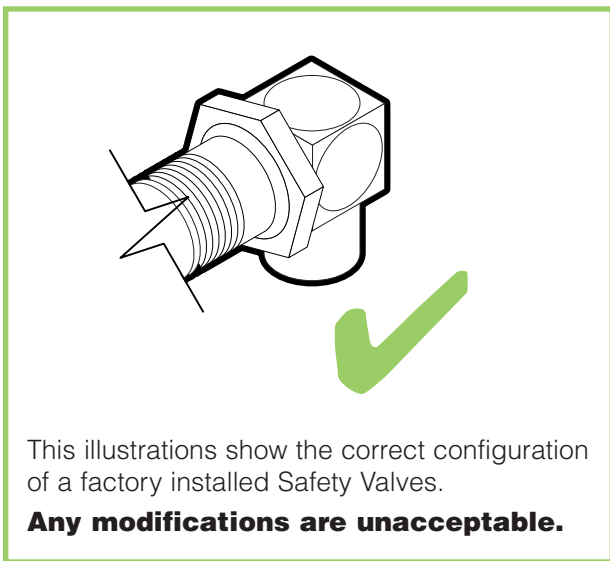

Incorrect Installations

- 1** Safety valve has plug threaded into the discharge opening preventing any steam from escaping.
- 2** Safety valve's tube diameter has been reduced.
- 3** Safety valve is sticking, frozen shut or plugged. To test, refer to page 23, PRESSURE RELIEF VALVE PERIODIC TESTING PROCEDURE.
- 4** Safety valve is plumbed to a drain or water line creating back pressure and reducing flow.

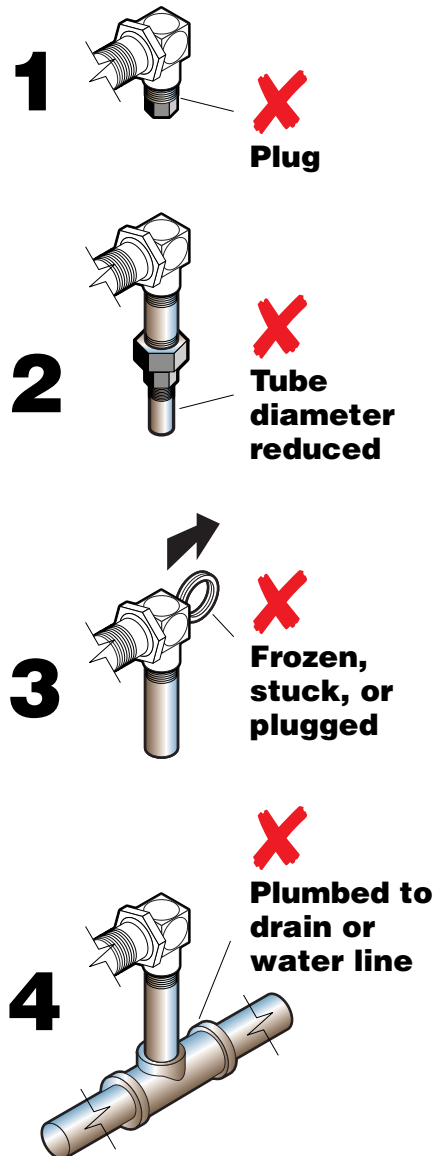

This illustrations show the correct configuration of a factory installed Safety Valves.

Any modifications are unacceptable.

SAFETY INSPECTION CHECKLIST-

TILTING MODELS (pg. 2 of 2)

SAFETY THERMOSTAT:

Incorrect Installations

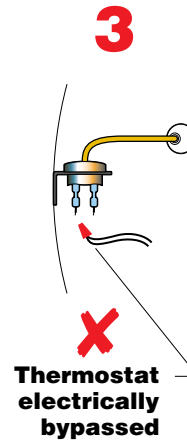
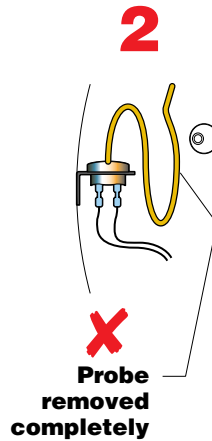
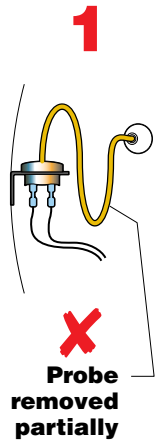
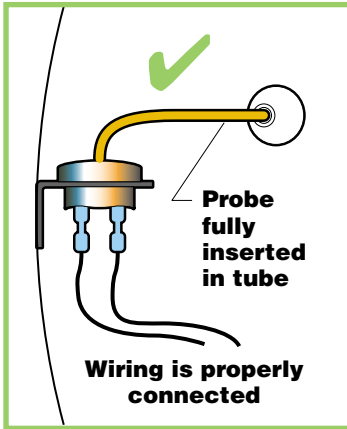

1 Safety thermostat probe is not completely inserted into tubing.

2 Safety thermostat probe is removed from tubing.

3 Safety thermostat electrical connection is bypassed.

Low Water Level Probe:

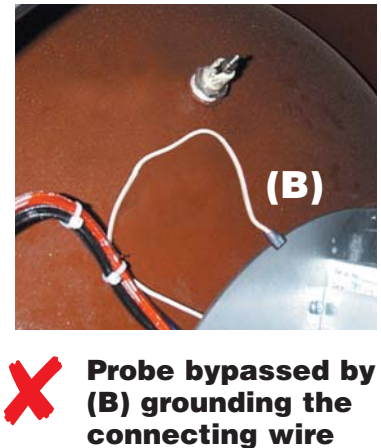
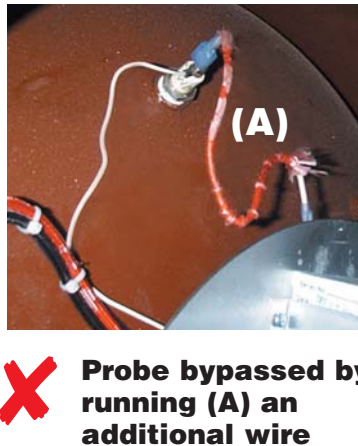

Operating Thermostat:

265°

260° - 270°
MAXIMUM KETTLE TEMPERATURE

If maximum temperature is not in this range (on empty kettle), refer to the CALIBRATING PROCEDURE on page #23.

LUBRICATION PROCEDURE

Lubricate the following parts every three months to insure smooth operation and reduce wear.

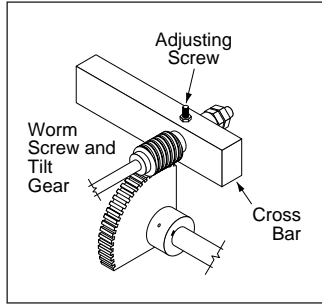

TRUNNION HOUSING, WORM SCREW AND TILT GEAR

These parts are accessed through the top cover of the console.

Apply grease to gear teeth. Check for

excessive play and adjust with adjusting screw located on top of cross bar.

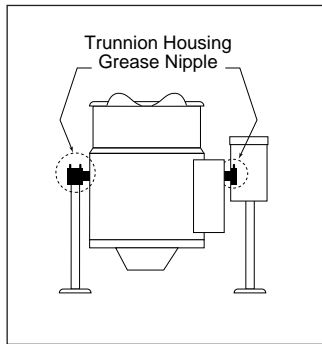

KETTLE TRUNNIONS

On the left hand side of the kettle there are two grease nipples on the top back portion of the trunnion housing. On the right hand side of the kettle you must remove the console cover to access the grease nipple.

HINGE ADJUSTMENT INSTRUCTIONS

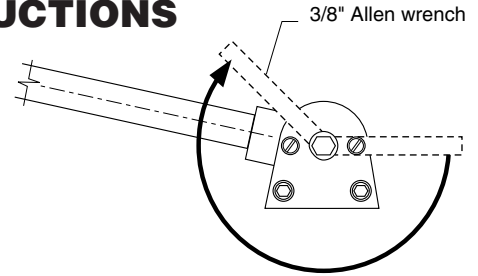

1. Insert 3/8" Allen wrench.
2. Turn clockwise to relieve tension on spring.
3. While tension is released remove one of the two slotted screws.
4. To prevent Allen wrench from springing back abruptly while the second slotted screw is removed, insert a pin (approximately 1/8") in the hole where the first slotted screw was removed from.
5. Remove second slotted screw.
6. While holding Allen wrench remove pin.
7. Turn Allen wrench clockwise to tighten or counter-clockwise to loosen tension to produce desired effect.
8. Re-insert pin in one of the two holes.
9. Tighten one slotted screw in the other hole (it may be necessary to turn Allen wrench slightly to align holes).
10. Remove pin and repeat step number 9. for other slotted screw.

CALIBRATING PROCEDURE

1. Insure the unit has a vacuum before you begin calibrating procedures. If unit requires venting refer to Kettle VENTING INSTRUCTIONS on page #26.
2. Set On-Off Switch/Temperature Control to "10" (Max.).
3. Allow the unit to cycle twice.
4. Check temperature of the inner kettle surface with a digital surface thermometer.
5. Temperature should be between 260° F and 265° F.
6. Using a screw driver adjust temperature by turning the potentiometer on the black box. Turn very little. Turn clockwise to INCREASES and counter-clockwise to DECREASE temperature.
7. Allow the unit to cycle twice.
8. Check temperature of the inner kettle surface with a digital surface thermometer.
9. Repeat steps 4. through 8. until unit is calibrated.

Pressure Relief Valve/Gauge Assembly Drawing

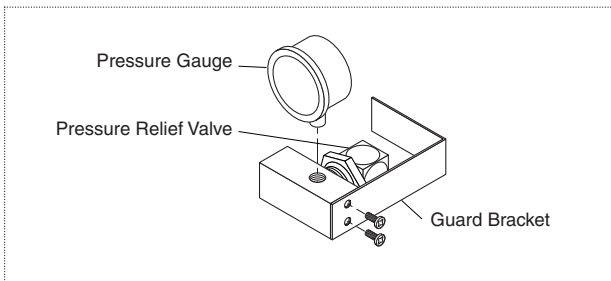

PRESSURE RELIEF VALVE PERIODIC TESTING PROCEDURE

WARNING: IMPROPER REFILLING OF KETTLE JACKET WILL RESULT IN IRREVERSIBLE DAMAGE TO UNIT.

Most insurance agencies require periodic testing of pressure relief valves used on pressure vessels. This procedure will allow you to safely and quickly test your kettle's pressure relief valve. We recommend this test be performed twice a year.

NOTE: The following instruction is intended for use by qualified service personnel.

WARNING: Kettle surface will be hot and steam will be released during testing. Take necessary precautions including the use of gloves and eye protection to prevent personal injury.

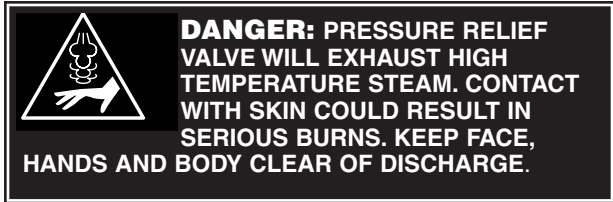

1. Remove guard bracket from pressure relief valve/gauge assembly.
2. With the kettle empty, set On-Off Switch/Temperature Control to "10" (Max.). Allow the kettle to heat until the unit cycles off.
3. Switch On-Off Switch/Temperature Control to "0" (Off) and disconnect main power at fused disconnect switch.

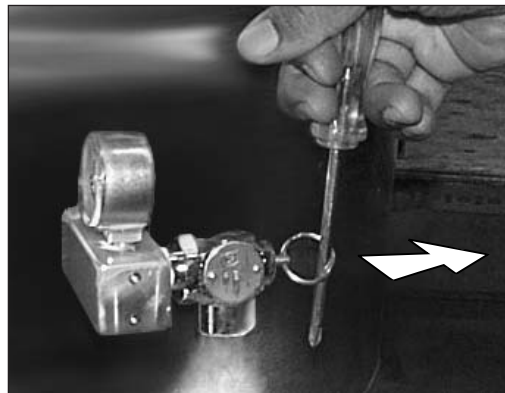

4. Stand to the side of the pressure relief valve discharge tube and pull valve open for a maximum of one second. Repeat test three to four times. Each time the mechanism should move freely and be accompanied by a rapid escape of steam.
5. Replace guard bracket from pressure relief valve/gauge assembly.

If valve appears to be sticking replace pressure relief valve.

If foreign material is discharged then drain kettle (see KETTLE JACKET FILLING & DRAINING PROCEDURES on page #25) and replace pressure relief valve.

See RESERVOIR FILL PROCEDURE (page #24) for full instructions on the correct method for refilling kettle jacket.

WARNING: Improper refilling of kettle jacket will result in irreversible damage to unit.

NOTE: Rust inhibitor is purchased locally. Read directions and do not exceed manufacturer's recommendation (excessive rust inhibitor can also cause solidification).

RESERVOIR FILL PROCEDURES

WARNING: IMPROPER REFILLING OF KETTLE JACKET WILL RESULT IN IRREVERSIBLE DAMAGE TO UNIT.

The kettle's water level must be maintained at the proper level. Under normal operating conditions, the sealed water reservoir should never require the addition of water.

If the red "low water" light comes on during use (while the kettle is in an upright position), the water level has reached a critically low level. The low water protection control has automatically shut off the gas burner. The following procedure must be completed before further use:

 **DANGER: PRESSURE RELIEF VALVE WILL EXHAUST HIGH TEMPERATURE STEAM. CONTACT WITH SKIN COULD RESULT IN SERIOUS BURNS. KEEP FACE, HANDS AND BODY CLEAR OF DISCHARGE.**

 **DANGER: WORKING ON MACHINES WITH POWER COULD RESULT IN SEVERE ELECTRICAL SHOCK.**

NOTE: Have a qualified service technician repair the leakage problem and add water to the unit. Ensure that the red "low water" light is on when the kettle is upright. On tilting kettles, it is normal for the red light to come on when the kettle is in a tilted position.

CAUTION: Only distilled water should be used when adding water to a partially filled water reservoir (If unit is completely empty see KETTLE JACKET FILLING & DRAINING PROCEDURES on page #25). Local tap water conditions may cause kettle damage which is not covered under warranty. Rust inhibitor is purchased locally. Read directions and do not exceed manufacturer's recommendation (excessive rust inhibitor can also cause solidification).

DISTILLED WATER REQUIREMENTS

Kettle Capacity	When red "Low Water Light" comes on, add distilled water	When the reservoir is completely empty, add distilled water
25 gallon	Approximately 1 gal.	4.4 gallon

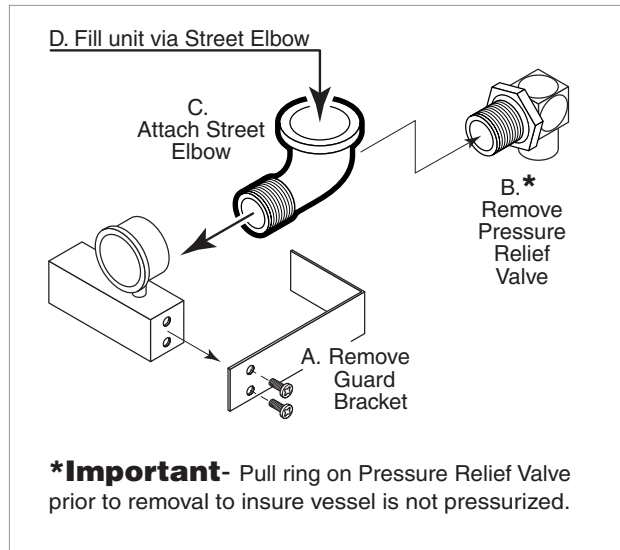

Pressure Relief Valve/Gauge Assembly Drawing

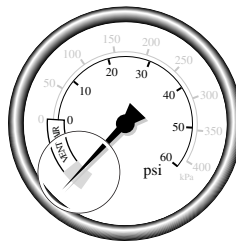

1. Ensure kettle is at room temperature and pressure gauge showing zero or less pressure.
2. Shut off power to the kettle at the fused disconnect switch.

3. Remove Guard Bracket (A).
4. Pull Pressure Relief Valve (B) open to insure vessel is not pressurized.
5. Remove Pressure Relief Valve (B).
6. Replace Pressure Relief Valve (B) with Street Elbow (C).

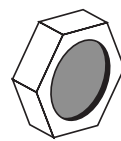

Sight Glass

7. Add distilled water (D) through the Street Elbow (C), using a funnel if necessary. Fill the unit to the high level mark on the Sight Glass.

8. Apply a thread sealant (i.e. Teflon tape) to the Pressure Relief Valve's (B) thread and replace.
9. Replace Guard Bracket (A).
10. Restore power to unit at the fused disconnect switch.
11. The kettle must now be vented. (Refer to the KETTLE VENTING INSTRUCTIONS on page #26).

KETTLE JACKET FILLING & DRAINING PROCEDURES

Under normal circumstances the kettle does not require the draining of all fluid. If the red "low water" light is on, follow the Reservoir Fill Procedures (page #9) in this manual.

If unit must be drained follow the procedures described on the following pages.

WARNING: IMPROPER REFILLING OF KETTLE JACKET WILL RESULT IN IRREVERSIBLE DAMAGE TO UNIT.

Use only a mixture of water and rust inhibitor to refill kettle jacket (see instructions below).

Contact your local water treatment company and purchase rust inhibitor with the specifications described below.

Recommended Corrosion Inhibitors for Closed Systems.

DESCRIPTION

Recommended for our units is a blend of SODIUM NITRITE and BORAX for corrosion inhibition of ferrous metals and axoles for copper and copper alloy corrosion protection. Product should be formulated for hot or cold closed recirculating water systems.

Source the chemicals stated above from your local water treatment company. Mix only with water and follow manufactures recommended mixing rate.

DISPOSAL OF INHIBITOR

Do not dispose of chemicals in any system which may discharge into water supplies used for drinking or washing or that could accidentally discharge into such systems, or into stream accessible to animals.

Follow all Federal, State and local codes when disposing of product.

Refill Quantities (water and corrosion inhibitor mixture)		
Kettle Size	U.S. Gallons	Liters
25 gallon	4.4	16.6

Draining Procedure



DANGER: WORKING ON MACHINES WITH POWER COULD RESULT IN SEVERE ELECTRICAL SHOCK.



DANGER: PRESSURE RELIEF VALVE WILL EXHAUST HIGH TEMPERATURE STEAM. CONTACT WITH SKIN COULD RESULT IN SERIOUS BURNS. KEEP FACE, HANDS AND BODY CLEAR OF DISCHARGE.



DANGER: EXTREMELY HOT SURFACES. WORK ONLY ON COLD KETTLE.

1. Shut off gas supply.
2. Disconnect gas line and electrical connection.
3. Remove bolts holding kettle to table.
4. Pull ring on pressure relief valve to insure there is no pressure within the kettle jacket.

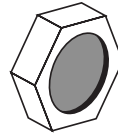

Sight Glass

5. Remove sight glass.
6. Tilt kettle on its side (sight glass down) and allow to drain (pull ring on pressure relief valve to speed up draining).
7. Tilt kettle upright and refill with water. Tilt kettle again on its side and allow to drain. Repeat until water drains clear.
8. Apply a thread sealant (i.e. Teflon tape) to the sight glass threads and replace.

Refilling Unit (see RESERVOIR FILL PROCEDURES on page #24 for details).

KETTLE VENTING INSTRUCTIONS

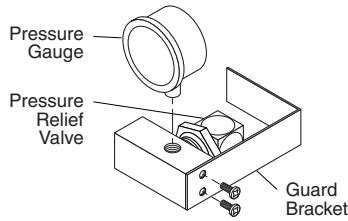
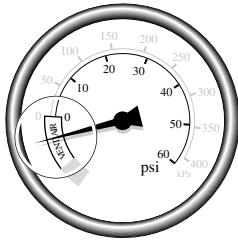

The following venting procedure should be followed when the Vacuum/Pressure Gauge needle is in the "VENT AIR" zone:

NOTE: Check for and eliminate leaks prior to venting (See REPAIRING LEAKS IN STEAM JACKETED KETTLE FITTINGS on page #27).



DANGER: PRESSURE RELIEF VALVE WILL EXHAUST HIGH TEMPERATURE STEAM. CONTACT WITH SKIN COULD RESULT IN SERIOUS BURNS. KEEP FACE, HANDS AND BODY CLEAR OF DISCHARGE.



DANGER: WORKING ON MACHINES WITH POWER COULD RESULT IN SEVERE ELECTRICAL SHOCK.

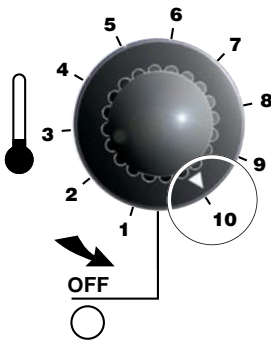

1. Remove guard bracket from pressure relief valve/gauge assembly.
2. Set On-Off Switch/Temperature Control to to "10" (Max.), heat the empty kettle until unit cycles off.
3. Vent kettle by pulling safety valve ring 8-10 times in short 2-3 second blasts with a 5 second interval between pulls.

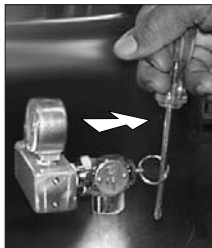

NOTE: If unit cycles ON, stop venting and wait for kettle to cycle OFF before continuing.

4. Set On-Off Switch/Temperature Control to to "0" (Max.). Add cold water to kettle until its surface temperature is below 100°F. The pressure gauge needle should be in the green zone, indicating a vacuum in the kettle's jacket.
5. Replace guard bracket from pressure relief valve/gauge assembly.

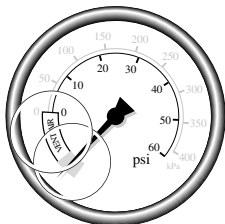

VACUUM LEAK TEST PROCEDURE

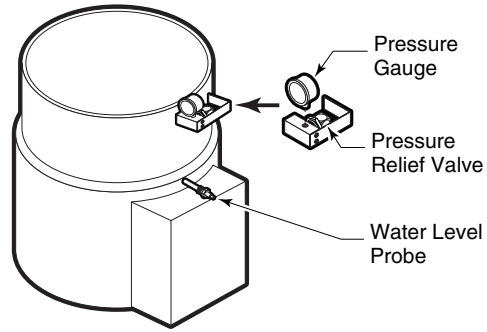

If the kettle will not hold vacuum, test for leaks at:

- A. Water Level Probe.
- B. Pressure Relief Valve.
- C. Pressure Gauge.

LEAK TEST PROCEDURE:

1. Heat kettle until unit cycles off.
2. Shut off power to the kettle at the fused disconnect switch.
3. Spread Bubble Type Leak Detector over suspected areas and watch closely for bubbles.
4. Repair areas as required.

REPAIRING LEAKS IN STEAM JACKETED KETTLE FITTINGS

If unit will not hold a vacuum the most likely cause is a leak at one of the fittings.

Often, the easiest way to eliminate a leak is reseal the suspect areas.

1. Water Level Probe
 - Remove, clean threads, apply teflon thread sealant and reinstall.
2. Pressure Relief Valve
 - A/ Inspect for signs of leaks. Replace if required.
 - B/ Remove, clean threads, apply teflon thread sealant and reinstall.
3. Pressure Gauge
 - A/ Inspect face of gauge. If it contains moisture on the inside of face replace.

SEQUENCE OF OPERATIONS

- 1.** To turn the unit on, turn the switch to the on position.
 - Power is sent to primary side of the 120vac/16vac transformer.
 - Power is sent to the normally closed high limit.
 - From the high limit power is sent to the normally open contacts of the 12VDC relay.
- 2.** From the secondary of the transformer 16VAC is sent to the controller.
 - Power is sent to the red LED (low water indicator light) from terminal 4 of the controller.
 - If the water probe is grounded through water the LED will go off.
 - If the water probe is not grounded the LED will remain on and the unit will not heat.
 - If the resistance of the thermistor is higher than the setting of the potentiometer(the unit is calling for heat) then 16VDC is sent to the coil of the relay and the green LED (heat indicator light)
 - The 12VDC relay will close until the unit reaches temperature
- 3.** With the contacts of the relay closed, power is sent to the 24 VAC transformer.
 - The transformer sends 24 VAC to the ignition module.
 - Ignition module sends 24 VAC to the Amber LED
 - The ignition module will send spark to the igniter and 24 VAC to the gas valve.
 - With 24VAC to the gas valve the valve opens and gas is sent to the burner.
 - Spark and gas together cause ignition.
 - When this happens and the module reads at least 0.7 micro amps DC within 4 seconds, the Amber light will go out and the 24 VAC will remain on the gas valve.
 - The unit will heat causing the water to boil and steam to be generated.
 - If the module does not see the 0.7 micro-amps in 4 seconds, the module will try again in 15 seconds. It will try 3 times then lock out.
- 4.** The kettle will heat (build pressure) until the controller is satisfied by the thermistor at the setting of the potentiometer.
 - The controller will then turn off the heat circuit until the temperature of the kettle is below the setting.
 - When the temperature drops below the setting the controller will send 12 VDC to the relay and the heat circuit will be energized again.
- 5.** To turn the unit off, place the switch in the off position.
 - Power will be removed from the controller and the heat circuit will de-energize.

**PROBLEM:
KGL-25
Kettle Won't
Heat**



**PROBLEM:
KGL-25
Kettle Not
Hot Enough**

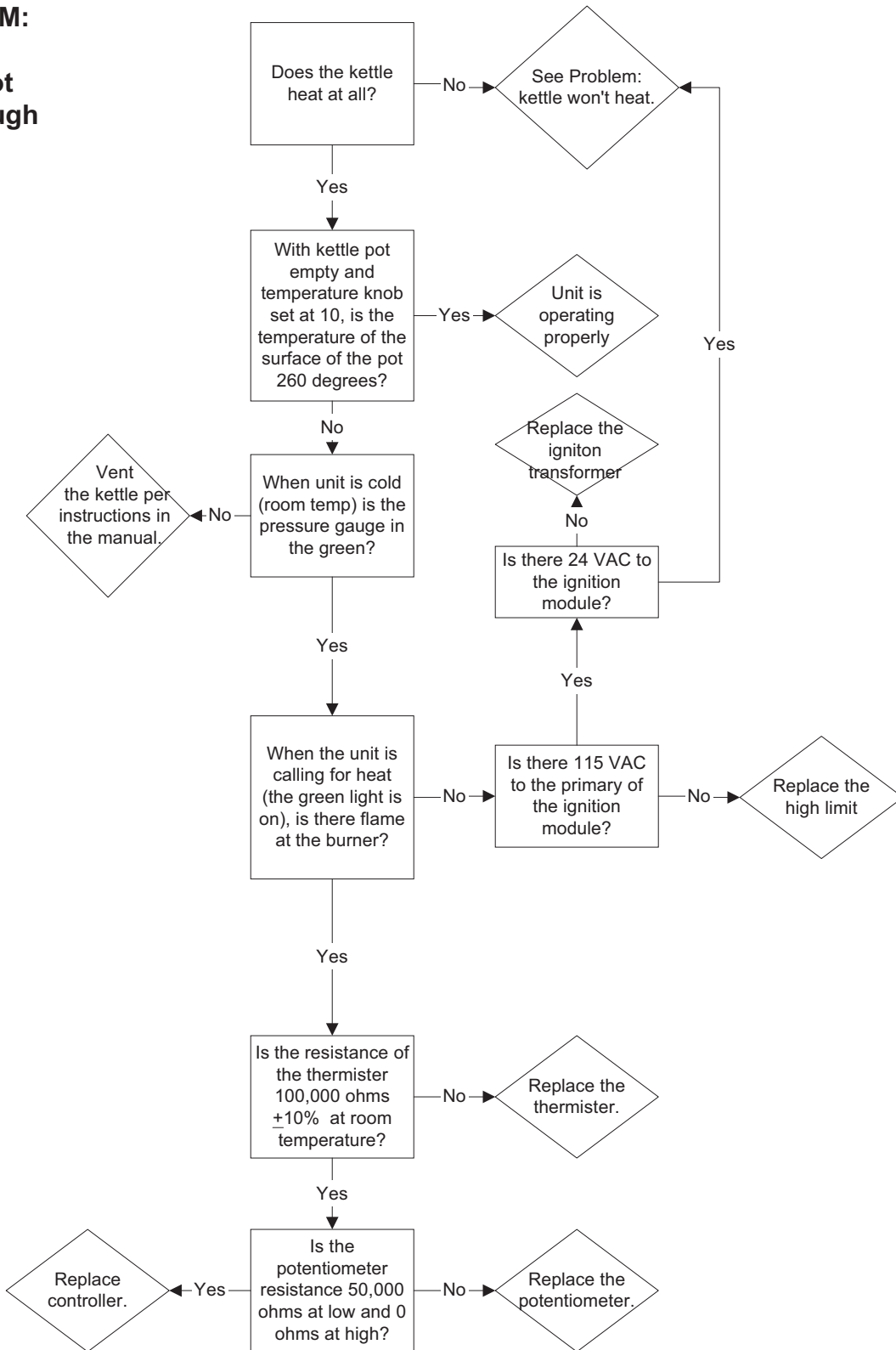

**PROBLEM:
KGL-25
Kettle Gets
Too Hot**

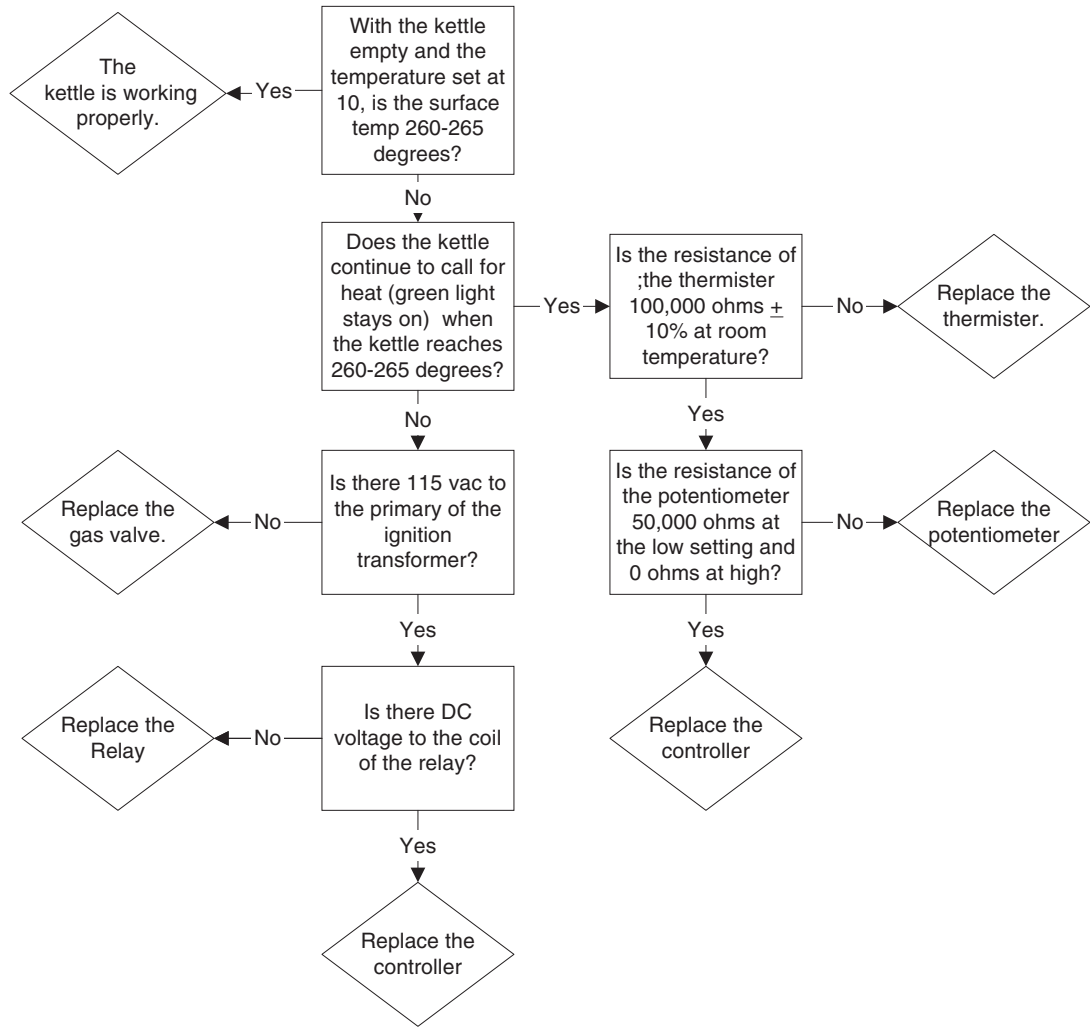

PROBLEM: Red Add Water LED Stays On

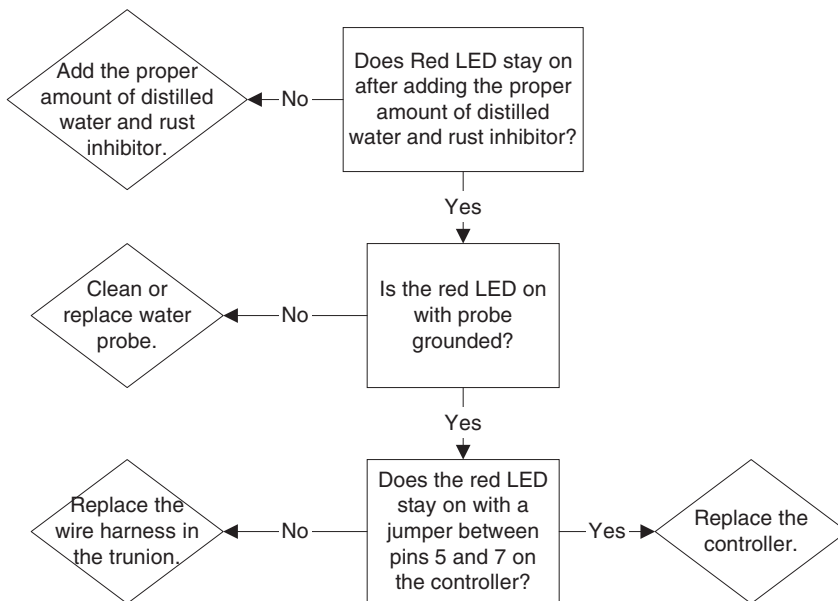

Symbol Legend (page 1 of 2)

□ English □ French □ Spanish □ Italian □ German □ Chinese-Simplified □ Chinese-Traditional

	<p>RISK OF ELECTRICAL SHOCK DANGER DE SECOUSSE ÉLECTRIQUE PELIGRO DE ELECTROCHOQUE PERICOLO DI SCOSSA STROMSCHLAG-GEFAHR</p>	<p>有触电危險 有觸電危險</p>
	<p>SPLASHPROOF ANTIÉCLABOUSSURES A PRUEBA DE SALPICADURAS PROTETTO CONTRO GLI SPRUZZI SPRITZWASSERDICHT</p>	<p>防濺水的 防濺水的</p>
	<p>DISCONNECT ELECTRICAL SUPPLY BEFORE WORKING ON KETTLE COUPER LE COURANT AVANT D'INTERVENIR SUR L'ÉQUIPEMENT DESCONECTAR LA ALIMENTACION ELECTRICA ANTES DE REALIZAR TRABAJOS EN EL EQUIPO DISINSERIRE LA CORRENTE PRIMA DI LAVORARE SULLA MACCHINA STROMVERSORGUNG AUSSCHALTEN, BEVOR AM GERÄT GEARBEITET WIRD</p>	<p>操作设备前切断电源 操作設備前切斷電源</p>
	<p>MAIN POWER ALIMENTATION ÉLECTRIQUE ALIMENTACION PRINCIPAL ALIMENTAZIONE HAUPTSTROM</p>	<p>主电源 主電源</p>
	<p>ON MARCHE ENCENDIDO ACCESO AN</p>	<p>开 開</p>
	<p>OFF ARRÊT APAGADO SPENTO AUS</p>	<p>关 關</p>
	<p>PAUSE, INTERRUPTION PAUSE, INTERRUPTION PAUSA, INTERRUPCION PAUSA, INTERRUZIONE PAUSE, UNTERBRECHUNG</p>	<p>暫停，间断 暫停，間斷</p>
	<p>CONTINUE CONTINUER CONTINUAR CONTINUA WEITER</p>	<p>继续 繼續</p>
	<p>RESET RÉENCLANCHER RECONECTAR RESET NULLSTELLEN</p>	<p>重新设定 重新設定</p>
	<p>START OF ACTION DÉBUT DE L'ACTION INICIAR FUNCIONAMIENTO INIZIO OPERAZIONE FUNKTION STARTEN</p>	<p>开始操作 開始操作</p>
	<p>STOP OF ACTION ARRÊT DE L'ACTION PARAR FUNCIONAMIENTO ARRESTO OPERAZIONE FUNKTION STOPPEN</p>	<p>停止操作 停止操作</p>
	<p>FAST START DÉMARRAGE RAPIDE INICIO RAPIDO AVVIAMENTO RAPIDO SCHNELLER START</p>	<p>快启动 快啓動</p>
	<p>FAST STOP, EMERGENCY ARRÊT RAPIDE D'URGENCE PARADA RAPIDA, EMERGENCIA ARRESTO RAPIDO, EMERGENZA SCHNELLER STOPP, NOTFALL</p>	<p>快止动，紧急 快止動，緊急</p>

Symbol Legend (page 2 of 2)

□ English □ French □ Spanish □ Italian □ German □ Chinese-Simplified □ Chinese-Traditional



AUTOMATIC TEMPERATURE CONTROL
 COMMANDE AUTOMATIQUE DE LA TEMPÉRATURE
 AJUSTE AUTOMÁTICO DE TEMPERATURA
 CONTROLLO AUTOMATICO TEMPERATURA
 AUTOMATISCHE TEMPERATURREGELUNG

自动温度控制
 自動溫度控制



LOW WATER
 NIVEAU BAS DE L'EAU
 NIVEL DE AGUA BAJO
 LIVELLO BASSO
 WASSERSTAND NIEDRIG

低水量
 低水量



BURNER AND/OR ELEMENT ENERGIZED
 BRÛLEUR ET/OU ÉLÉMENT ALLUMÉ
 QUEMADOR O ELEMENTO ENCENDIDO
 FIAMMA E/O ELEMENTO ATTIVATI
 BRENNER ODER ELEMENT EINGESCHALTET

燃烧器和/或元件带电
 燃燒器和/或元件帶電



IGNITION FAILURE
 PANNE D'ALLUMAGE
 FALLO DE ENCENDIDO
 MANCATA ACCENSIONE
 ZÜNDUNGSFEHLER

点火失效
 點火失效



HEATING
 ÉBULLITION
 CALEFACCION
 RISCALDAMENTO
 HEIZUNG

加热
 加熱



COOLING
 REFROIDISSEMENT
 REFRIGERACION
 RAFFREDDAMENTO
 KÜHLUNG

冷却
 冷卻



HEAT ADJUSTMENT
 RÉGLAGE DE LA CHALEUR
 REGULACION DE CALOR
 REGOLAZIONE RISCALDAMENTO
 WÄRMEREGULIERUNG

热调节
 熱調節

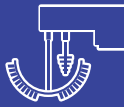

MIXER BRIDGE
 PONT DU MÉLANGEUR
 PUENTE DE MEZCLADORA
 MENSOLA MESCOLATORE
 MISCHER-BRÜCKE

搅拌桥
 攪拌橋



LEFT KETTLE
 BOUILLLOIRE GAUCHE
 HERVIDOR IZQUIERDO
 BOLLITORE SINISTRO
 LINKER KOCHKESSEL

左壺
 左壺



RIGHT KETTLE
 BOUILLLOIRE DROITE
 HERVIDOR DERECHO
 BOLLITORE DESTRO
 RECHTER KOCHKESSEL

右壺
 右壺



MIX
 MÉLANGER
 MEZCLAR
 MESCOLATURA
 MISCHEN

混合
 混合



LIFT
 LEVER
 LEVANTAR
 SOLLEVARE
 HEBEN

提升
 提升



UP
 HAUT
 ARRIBA
 SU
 RAUF

向上
 向上



DOWN
 BAS
 ABAJO
 GIÙ
 RUNTER

向下
 向下



HOT WATER
 EAU CHAUDE
 AGUA CALIENTE
 ACQUA CALDA
 HEISSES WASSER

热水
 熱水



COLD WATER
 EAU FROIDE
 AGUA FRIA
 ACQUA FREDDA
 KALTES WASSER

冷水
 冷水