

## BATCH BUCKET WITH DOLLY

### BATCH BUCKETS

#### Cleveland Standard Features

- Large, bucket for loading product load via hoist system into kettles
- Stainless steel construction
- Cone shape bottom with 14" diameter sliding dump gate
- Accepted for use in U.S.D.A. Inspected Facilities

#### Options & Accessories

- Special sizes upon request
- Bucket with 3" ball valve for loading liquids

### BATCH BUCKET DOLLIES

#### Cleveland Standard Features

- Type 304 stainless steel construction
- Heavy duty design
- Large 5" diameter casters, two with brakes
- Accepted for use in U.S.D.A. Inspected Facilities

MODELS:  BB-60  BB-100



MODELS:  BBD-60  BBD-100



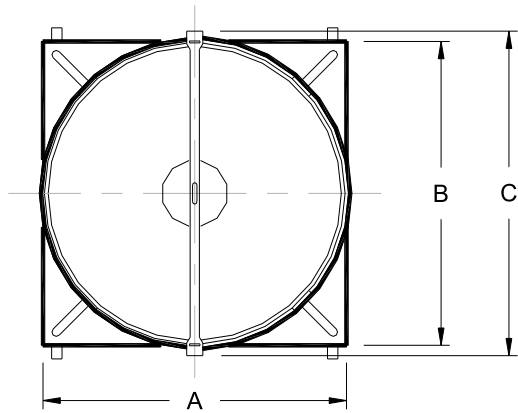

PLAN VIEW

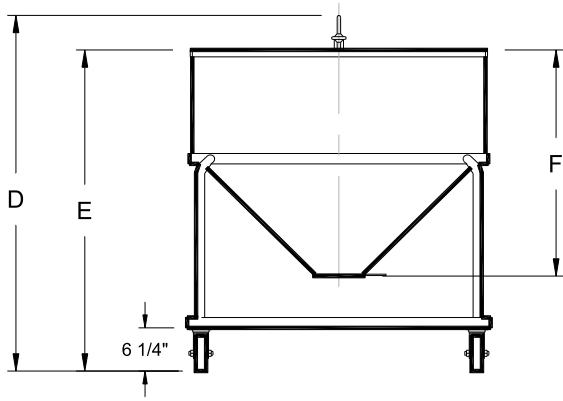

FRONT VIEW

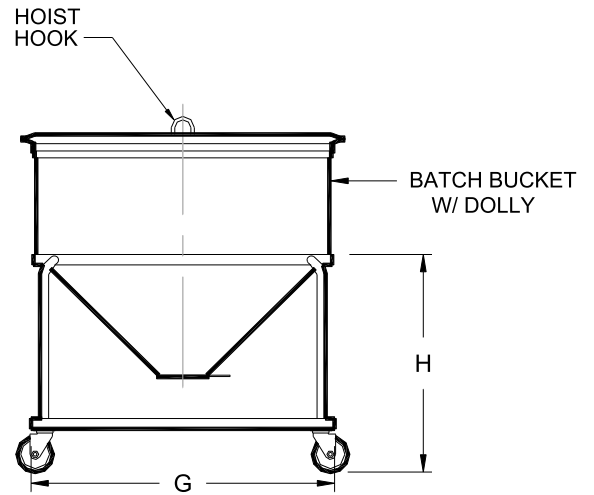

SIDE VIEW

**DIMENSIONS**

MODEL	A	B	C	D	E	F	G	H
BB-60	28 1/2"	28 1/2"	31 1/2"	40"	35"	21 1/4"	28 1/2"	23 3/4"
BB-100	34 1/2"	34 1/2"	37 1/2"	44"	39"	25 1/4"	34 1/2"	26 3/4"