



Miller®

March 1993

Form: OM-351H

Effective With Serial No. KD368924

OWNER'S MANUAL

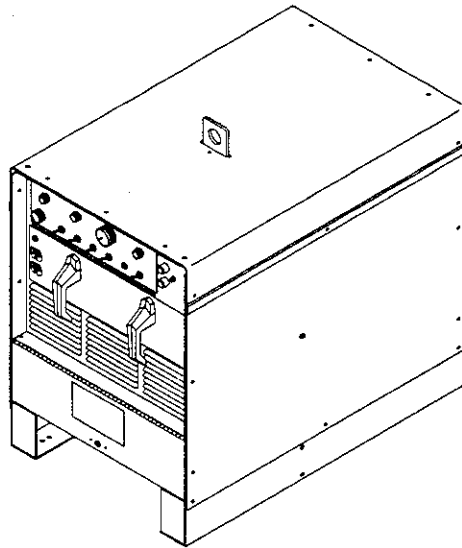

330ST Aircrafter®

- CC, AC/DC Welding Power Source
- For SMAW And GTAW Welding
- 300 Amperes, 32 Volts AC/DC At 60% Duty Cycle
- Single-Phase Input Power
- Protection For Control Circuitry, 24 And 115 VAC, And Overheating
- 14-Pin Remote Receptacle
- High Frequency Switch

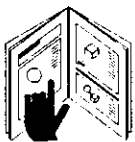

- Read and follow these instructions and all safety blocks carefully.
- Have only trained and qualified persons install, operate, or service this unit.*
- Call your distributor if you do not understand the directions.



- Give this manual to the operator.



- For help, call your distributor
- or: MILLER ELECTRIC Mfg. Co., P.O. Box 1079, Appleton, WI 54912 414-734-9821

MILLER'S TRUE BLUE™ LIMITED WARRANTY

Effective January 1, 1992
(Equipment with a serial number preface of "KC" or newer)

This limited warranty supersedes all previous MILLER warranties and is exclusive with no other guarantees or warranties expressed or implied.

LIMITED WARRANTY - Subject to the terms and conditions below, MILLER Electric Mfg. Co., Appleton, Wisconsin, warrants to its original retail purchaser that new MILLER equipment sold after the effective date of this limited warranty is free of defects in material and workmanship at the time it is shipped by MILLER. THIS WARRANTY IS EXPRESSLY IN LIEU OF ALL OTHER WARRANTIES, EXPRESS OR IMPLIED, INCLUDING THE WARRANTIES OF MERCHANTABILITY AND FITNESS.

Within the warranty periods listed below, MILLER will repair or replace any warranted parts or components that fail due to such defects in material or workmanship. MILLER must be notified in writing within thirty (30) days of such defect or failure, at which time MILLER will provide instructions on the warranty claim procedures to be followed.

MILLER shall honor warranty claims on warranted equipment listed below in the event of such a failure within the warranty time periods. All warranty time periods start on the date that the equipment was delivered to the original retail purchaser, and are as follows:

1. 5 Years Parts - 3 Years Labor
 - * Original main power rectifiers
2. 3 Years - Parts and Labor
 - * Transformer/Rectifier Power Sources
 - * Plasma Arc Cutting Power Sources
 - * Semi-Automatic and Automatic Wire Feeders
 - * Robots
3. 2 Years - Parts and Labor
 - * Engine Driven Welding Generators
(NOTE: Engines are warranted separately by the engine manufacturer.)
4. 1 Year - Parts and Labor
 - * Motor Driven Guns
 - * Process Controllers
 - * Water Coolant Systems
 - * HF Units
 - * Grids
 - * Spot Welders
 - * Load Banks
 - * SDX Transformers
 - * Running Gear/Trailers
 - * Field Options

(NOTE: Field options are covered under True Blue™ for the remaining warranty period of the product they are installed in, or for a minimum of one year - whichever is greater.)
5. 6 Months - Batteries
6. 90 Days - Parts and Labor
 - * MIG Guns/TIG Torches
 - * Plasma Cutting Torches
 - * Remote Controls

- * Accessory Kits
- * Replacement Parts

MILLER'S True Blue™ Limited Warranty shall not apply to:

1. Items furnished by MILLER, but manufactured by others, such as engines or trade accessories. These items are covered by the manufacturer's warranty, if any.
2. Consumable components; such as contact tips, cutting nozzles, contactors and relays.
3. Equipment that has been modified by any party other than MILLER, or equipment that has been improperly installed, improperly operated or misused based upon industry standards, or equipment which has not had reasonable and necessary maintenance, or equipment which has been used for operation outside of the specifications for the equipment.

MILLER PRODUCTS ARE INTENDED FOR PURCHASE AND USE BY COMMERCIAL/INDUSTRIAL USERS AND PERSONS TRAINED AND EXPERIENCED IN THE USE AND MAINTENANCE OF WELDING EQUIPMENT.

In the event of a warranty claim covered by this warranty, the exclusive remedies shall be, at MILLER'S option: (1) repair; or (2) replacement; or, where authorized in writing by MILLER in appropriate cases, (3) the reasonable cost of repair or replacement at an authorized MILLER service station; or (4) payment of or credit for the purchase price (less reasonable depreciation based upon actual use) upon return of the goods at customer's risk and expense. MILLER'S option of repair or replacement will be F.O.B., Factory at Appleton, Wisconsin, or F.O.B. at a MILLER authorized service facility as determined by MILLER. Therefore no compensation or reimbursement for transportation costs of any kind will be allowed.

TO THE EXTENT PERMITTED BY LAW, THE REMEDIES PROVIDED HEREIN ARE THE SOLE AND EXCLUSIVE REMEDIES. IN NO EVENT SHALL MILLER BE LIABLE FOR DIRECT, INDIRECT, SPECIAL, INCIDENTAL OR CONSEQUENTIAL DAMAGES (INCLUDING LOSS OF PROFIT), WHETHER BASED ON CONTRACT, TORT OR ANY OTHER LEGAL THEORY.

ANY EXPRESS WARRANTY NOT PROVIDED HEREIN AND ANY IMPLIED WARRANTY, GUARANTY OR REPRESENTATION AS TO PERFORMANCE, AND ANY REMEDY FOR BREACH OF CONTRACT TORT OR ANY OTHER LEGAL THEORY WHICH, BUT FOR THIS PROVISION, MIGHT ARISE BY IMPLICATION, OPERATION OF LAW, CUSTOM OF TRADE OR COURSE OF DEALING, INCLUDING ANY IMPLIED WARRANTY OF MERCHANTABILITY OR FITNESS FOR PARTICULAR PURPOSE, WITH RESPECT TO ANY AND ALL EQUIPMENT FURNISHED BY MILLER IS EXCLUDED AND DISCLAIMED BY MILLER.

Some states in the U.S.A. do not allow limitations of how long an implied warranty lasts, or the exclusion of incidental, indirect, special or consequential damages, so the above limitation or exclusion may not apply to you. This warranty provides specific legal rights, and other rights may be available, but may vary from state to state.

In Canada, legislation in some provinces provides for certain additional warranties or remedies other than as stated herein, and to the extent that they may not be waived, the limitations and exclusions set out above may not apply. This Limited Warranty provides specific legal rights, and other rights may be available, but may vary from province to province.

RECEIVING-HANDLING

Before unpacking equipment, check carton for any damage that may have occurred during shipment. File any claims for loss or damage with the delivering carrier. Assistance for filing or settling claims may be obtained from distributor and/or equipment manufacturer's Transportation Department.

When requesting information about this equipment, always provide Model Designation and Serial or Style Number.

Use the following spaces to record Model Designation and Serial or Style Number of your unit. The information is located on the rating label or nameplate.

Model _____

Serial or Style No. _____

Date of Purchase _____

ARC WELDING SAFETY PRECAUTIONS

WARNING

ARC WELDING can be hazardous.

PROTECT YOURSELF AND OTHERS FROM POSSIBLE SERIOUS INJURY OR DEATH. KEEP CHILDREN AWAY. PACEMAKER WEARERS KEEP AWAY UNTIL CONSULTING YOUR DOCTOR.

In welding, as in most jobs, exposure to certain hazards occurs. Welding is safe when precautions are taken. The safety information given below is only a summary of the more complete safety information that will be found in the Safety Standards listed on the next page. Read and follow all Safety Standards.

HAVE ALL INSTALLATION, OPERATION, MAINTENANCE, AND REPAIR WORK PERFORMED ONLY BY QUALIFIED PEOPLE.



ELECTRIC SHOCK can kill.

Touching live electrical parts can cause fatal shocks or severe burns. The electrode and work circuit is electrically live whenever the output is on. The input power circuit and machine internal circuits are also live when power is on. In semiautomatic or automatic wire welding, the wire, wire reel, drive roll housing, and all metal parts touching the welding wire are electrically live. Incorrectly installed or improperly grounded equipment is a hazard.

1. Do not touch live electrical parts.
2. Wear dry, hole-free insulating gloves and body protection.
3. Insulate yourself from work and ground using dry insulating mats or covers.
4. Disconnect input power or stop engine before installing or servicing this equipment.

5. Properly install and ground this equipment according to its Owner's Manual and national, state, and local codes.
6. When making input connections, attach proper grounding conductor first.
7. Turn off all equipment when not in use.
8. Do not use worn, damaged, undersized, or poorly spliced cables.
9. Do not wrap cables around your body.
10. Ground the workpiece to a good electrical (earth) ground.
11. Do not touch electrode if in contact with the work or ground.
12. Use only well-maintained equipment. Repair or replace damaged parts at once.
13. Wear a safety harness if working above floor level.
14. Keep all panels and covers securely in place.

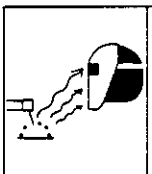

ARC RAYS can burn eyes and skin; NOISE can damage hearing.

Arc rays from the welding process produce intense heat and strong ultraviolet rays that can burn eyes and skin. Noise from some processes can damage hearing.

NOISE

1. Use approved ear plugs or ear muffs if noise level is high.

ARC RAYS

2. Wear a welding helmet fitted with a proper shade of filter (see ANSI Z49.1 listed in Safety Standards) to protect your face and eyes when welding or watching.
3. Wear approved safety glasses. Side shields recommended.
4. Use protective screens or barriers to protect others from flash and glare; warn others not to watch the arc.
5. Wear protective clothing made from durable, flame-resistant material (wool and leather) and foot protection.

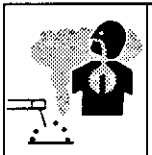

FUMES AND GASES can be hazardous to your health.

Welding produces fumes and gases. Breathing these fumes and gases can be hazardous to your health.

1. Keep your head out of the fumes. Do not breathe the fumes.
2. If inside, ventilate the area and/or use exhaust at the arc to remove welding fumes and gases.
3. If ventilation is poor, use an approved air-supplied respirator.
4. Read the Material Safety Data Sheets (MSDSs) and the manufacturer's instruction for metals, consumables, coatings, and cleaners.

5. Work in a confined space only if it is well ventilated, or while wearing an air-supplied respirator. Shielding gases used for welding can displace air causing injury or death. Be sure the breathing air is safe.
6. Do not weld in locations near degreasing, cleaning, or spraying operations. The heat and rays of the arc can react with vapors to form highly toxic and irritating gases.
7. Do not weld on coated metals, such as galvanized, lead, or cadmium plated steel, unless the coating is removed from the weld area, the area is well ventilated, and if necessary, while wearing an air-supplied respirator. The coatings and any metals containing these elements can give off toxic fumes if welded.



WELDING can cause fire or explosion.

Sparks and spatter fly off from the welding arc. The flying sparks and hot metal, weld spatter, hot workpiece, and hot equipment can cause fires and burns. Accidental contact of electrode or welding wire to metal objects can cause sparks, overheating, or fire.

1. Protect yourself and others from flying sparks and hot metal.
2. Do not weld where flying sparks can strike flammable material.
3. Remove all flammables within 35 ft (10.7 m) of the welding arc. If this is not possible, tightly cover them with approved covers.
4. Be alert that welding sparks and hot materials from welding can easily go through small cracks and openings to adjacent areas.

5. Watch for fire, and keep a fire extinguisher nearby.
6. Be aware that welding on a ceiling, floor, bulkhead, or partition can cause fire on the hidden side.
7. Do not weld on closed containers such as tanks or drums.
8. Connect work cable to the work as close to the welding area as practical to prevent welding current from traveling long, possibly unknown paths and causing electric shock and fire hazards.
9. Do not use welder to thaw frozen pipes.
10. Remove stick electrode from holder or cut off welding wire at contact tip when not in use.
11. Wear oil-free protective garments such as leather gloves, heavy shirt, cuffless trousers, high shoes, and a cap.

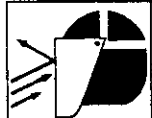

FLYING SPARKS AND HOT METAL can cause injury.

Chipping and grinding cause flying metal. As welds cool, they can throw off slag.

1. Wear approved face shield or safety goggles. Side shields recommended.
2. Wear proper body protection to protect skin.



CYLINDERS can explode if damaged.

Shielding gas cylinders contain gas under high pressure. If damaged, a cylinder can explode. Since gas cylinders are normally part of the welding process, be sure to treat them carefully.

1. Protect compressed gas cylinders from excessive heat, mechanical shocks, and arcs.
2. Install and secure cylinders in an upright position by chaining them to a stationary support or equipment cylinder rack to prevent falling or tipping.

3. Keep cylinders away from any welding or other electrical circuits.
4. Never allow a welding electrode to touch any cylinder.
5. Use only correct shielding gas cylinders, regulators, hoses, and fittings designed for the specific application; maintain them and associated parts in good condition.
6. Turn face away from valve outlet when opening cylinder valve.
7. Keep protective cap in place over valve except when cylinder is in use or connected for use.
8. Read and follow instructions on compressed gas cylinders, associated equipment, and CGA publication P-1 listed in Safety Standards.



WARNING

ENGINES can be hazardous.

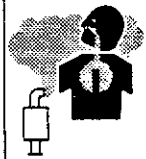

ENGINE EXHAUST GASES can kill.

Engines produce harmful exhaust gases.

1. Use equipment outside in open, well-ventilated areas.
2. If used in a closed area, vent engine exhaust outside and away from any building air intakes.



ENGINE FUEL can cause fire or explosion.

Engine fuel is highly flammable.

1. Stop engine before checking or adding fuel.
2. Do not add fuel while smoking or if unit is near any sparks or open flames.
3. Allow engine to cool before fueling. If possible, check and add fuel to cold engine before beginning job.
4. Do not overfill tank – allow room for fuel to expand.
5. Do not spill fuel. If fuel is spilled, clean up before starting engine.



MOVING PARTS can cause injury.

Moving parts, such as fans, rotors, and belts can cut fingers and hands and catch loose clothing.

1. Keep all doors, panels, covers, and guards closed and securely in place.
2. Stop engine before installing or connecting unit.

3. Have only qualified people remove guards or covers for maintenance and troubleshooting as necessary.
4. To prevent accidental starting during servicing, disconnect negative (-) battery cable from battery.
5. Keep hands, hair, loose clothing, and tools away from moving parts.
6. Reinstall panels or guards and close doors when servicing is finished and before starting engine.

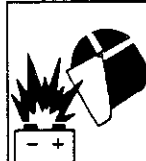

SPARKS can cause BATTERY GASES TO EXPLODE; BATTERY ACID can burn eyes and skin.

Batteries contain acid and generate explosive gases.

1. Always wear a face shield when working on a battery.
2. Stop engine before disconnecting or connecting battery cables.
3. Do not allow tools to cause sparks when working on a battery.
4. Do not use welder to charge batteries or jump start vehicles.
5. Observe correct polarity (+ and -) on batteries.

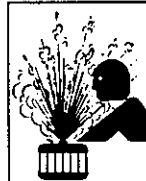

STEAM AND PRESSURIZED HOT COOLANT can burn face, eyes, and skin.

The coolant in the radiator can be very hot and under pressure.

1. Do not remove radiator cap when engine is hot. Allow engine to cool.
2. Wear gloves and put a rag over cap area when removing cap.
3. Allow pressure to escape before completely removing cap.

PRINCIPAL SAFETY STANDARDS

Safety in Welding and Cutting, ANSI Standard Z49.1, from American Welding Society, 550 N.W. LeJeune Rd, Miami FL 33126

Safety and Health Standards, OSHA 29 CFR 1910, from Superintendent of Documents, U.S. Government Printing Office, Washington, D.C. 20402.

Recommended Safe Practices for the Preparation for Welding and Cutting of Containers That Have Held Hazardous Substances, American Welding Society Standard AWS F4.1, from American Welding Society, 550 N.W. LeJeune Rd, Miami, FL 33126

National Electrical Code, NFPA Standard 70, from National Fire Protection Association, Batterymarch Park, Quincy, MA 02269.

Safe Handling of Compressed Gases in Cylinders, CGA Pamphlet P-1, from Compressed Gas Association, 1235 Jefferson Davis Highway, Suite 501, Arlington, VA 22202.

Code for Safety in Welding and Cutting, CSA Standard W117.2, from Canadian Standards Association, Standards Sales, 178 Rexdale Boulevard, Rexdale, Ontario, Canada M9W 1R3.

Safe Practices For Occupation And Educational Eye And Face Protection, ANSI Standard Z87.1, from American National Standards Institute, 1430 Broadway, New York, NY 10018.

Cutting And Welding Processes, NFPA Standard 51B, from National Fire Protection Association, Batterymarch Park, Quincy, MA 02269.

PRÉCAUTIONS DE SÉCURITÉ EN SOUDAGE À L'ARC

MISE EN GARDE

LE SOUDAGE À L'ARC est dangereux.

PROTÉGEZ-VOUS, AINSI QUE LES AUTRES, CONTRE LES BLESSURES GRAVES POSSIBLES OU LA MORT. NE LAISSEZ PAS LES ENFANTS S'APPROCHER, NI LES PORTEURS DE STIMULATEUR CARDIAQUE (A MOINS QU'ILS N'AIENT CONSULTÉ UN MÉDECIN).

Le soudage, comme la plupart des activités industrielles, expose à certains risques. Le soudage n'est pas dangereux lorsqu'on prend des précautions. Les consignes de sécurité suivantes ne font que résumer l'information contenue dans les normes énumérées ci-après. Lisez et respectez toutes ces normes.

SEULES DES PERSONNES QUALIFIÉES DOIVENT FAIRE DES TRAVAUX D'INSTALLATION, DE RÉPARATION, D'ENTRETIEN ET D'ESSAI.



L'ÉLECTROCUTION peut être mortelle.

Une décharge électrique peut vous tuer ou vous brûler gravement. L'électrode et le circuit de soudage sont sous tension au démarrage. Le circuit d'entrée et les circuits internes des matériels sont aussi sous tension dès la mise en marche. En soudage automatique ou semi-automatique avec fil, ce dernier, le support de roquette, le logement des galets d'entraînement et toutes les pièces métalliques en contact avec le fil de soudage sont sous tension. Des matériels mal installés ou mal mis à la terre sont dangereux.

1. Ne touchez pas à des pièces sous tension.
2. Portez des gants et des vêtements isolants, secs et non troués.
3. Isolez-vous de la tôle à souder et de la mise à la terre au moyen de petits tapis isolants ou autres.
4. Déconnectez la prise d'entrée des matériels ou arrêtez leur moteur avant de les installer ou d'en faire l'entretien.

5. Veillez à installer ces matériels et à les mettre à la terre selon le manuel d'utilisation et les codes nationaux, provinciaux et locaux applicables.
6. Arrêtez tous les matériels après utilisation.
7. N'utilisez pas de câbles usés, endommagés, mal épissés ou de calibre trop petits.
8. N'enroulez pas de câbles autour de votre corps.
9. Mettez à la terre la tôle à souder au moyen d'une bonne prise de terre.
10. Ne touchez pas à l'électrode si vous êtes en contact avec le circuit de soudage (terre).
11. N'utilisez que des matériels en bon état. Réparez ou remplacez sur-le-champ les pièces endommagées.
12. Portez un harnais de sécurité si vous travaillez en hauteur.
13. Fermez solidement tous les panneaux et les capots.



Le RAYONNEMENT DE L'ARC peut brûler les yeux et la peau; le BRUIT peut endommager l'ouïe.

L'arc de soudage produit une chaleur et des rayons ultraviolets intenses, susceptibles de brûler les yeux et la peau. Le bruit causé par certains procédés peut endommager l'ouïe.

1. Portez un casque de soudeur avec écran filtrant de teinte appropriée (consultez la norme ANSI Z49 indiquée ci-après), pour vous protéger le visage et les yeux lorsque vous soudez ou

que vous observez l'exécution d'une soudure.

2. Portez des lunettes de sécurité approuvées. Des écrans latéraux sont recommandés.
3. Entourez l'aire de soudage de rideaux ou de cloisons de protection contre les coups d'arc ou l'éblouissement; avertissez les observateurs de ne pas regarder l'arc.
4. Portez des vêtements en tissu ignifuge durable (laine et cuir) et des chaussures de sécurité.
5. Portez un casque antibruit ou des bouchons d'oreille approuvés si le niveau de bruit est élevé.



Les VAPEURS ET LES FUMÉES sont dangereuses pour la santé.

Le soudage dégage des vapeurs et des fumées qu'il est dangereux de respirer.

1. Écartez le visage pour éviter de respirer les fumées.
2. À l'intérieur, assurez-vous que l'aire de soudage est bien ventilée ou que les fumées et les vapeurs sont aspirées à l'arc.
3. Si la ventilation est mauvaise, portez un respirateur à adduction d'air approuvé.
4. Lisez les fiches signalétiques et les consignes du fabricant relatives aux métaux, aux produits consommables, aux revêtements et aux produits nettoyants.

5. Ne travaillez dans un espace confiné que s'il est bien ventilé; sinon, portez un respirateur à adduction d'air. Les gaz protecteurs de soudage peuvent déplacer l'oxygène de l'air et causer des blessures ou la mort. Assurez-vous que l'air est propre à la respiration.
6. Ne soudez pas à proximité d'opérations de dégraissage, de nettoyage ou de pulvérisation. La chaleur et les rayons de l'arc peuvent réagir avec des vapeurs et former des gaz hautement toxiques et irritants.
7. Ne soudez pas de tôles galvanisées ou plaquées en plomb ou en cadmium sans les avoir grattées à fond, car ces métaux, et tout revêtement qui en contient, peuvent alors dégager des fumées toxiques. Assurez-vous d'une bonne ventilation et portez un respirateur à adduction d'air si c'est nécessaire.



Le SOUDAGE peut causer un incendie ou une explosion.

L'arc produit des étincelles et des projections. Avec la chaleur intense dégagée par la tôle et les matériels, elles peuvent causer un incendie et des brûlures. Le contact accidentel de l'électrode avec un objet métallique peut provoquer des étincelles, un échauffement ou un incendie.

1. Protégez-vous, ainsi que les autres, contre les étincelles et les projections.
2. Ne soudez pas dans un endroit où des étincelles peuvent atteindre des matériaux inflammables.
3. Enlevez toutes les matières inflammables dans un rayon de 10,7 mètres autour de l'arc, ou couvrez-les soigneusement avec des bâches approuvées.
4. Méfiez-vous des étincelles et des éclats brûlants, susceptibles de pénétrer dans des aires adjacentes par de petites ouvertures ou fissures.

5. Méfiez-vous des incendies et gardez un extincteur à portée de la main.
6. N'oubliez pas qu'une soudure sur un plafond, un plancher, une cloison ou une paroi peut en enflammer l'autre côté.
7. Ne soudez pas un récipient fermé, comme un réservoir ou un tonneau.
8. Connectez le câble de soudage le plus près possible de la tôle de soudage pour empêcher le courant de suivre un parcours long et inconnu, et prévenir ainsi les risques d'électrocution et d'incendie.
9. Ne faites pas dégeler des tuyaux avec un chalumeau.
10. Videz votre carquois porte-électrodes ou coupez le fil au tube-contact après le soudage.
11. Portez des vêtements protecteurs non huileux, tels des gants en cuir, une chemise épaisse, un pantalon sans revers, des chaussures montantes et un casque.

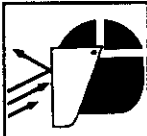

LES ÉTINCELLES ET LES PROJECTIONS BRULANTES peuvent causer des blessures.

Le piquage et le meulage produisent des éclats de

- métal. En refroidissant, la soudure peut projeter du laitier.
- 1. Portez un écran facial ou des lunettes à coques approuvées. Des écrans latéraux sont recommandés.
- 2. Portez des vêtements de protection individuelle appropriés.



Les BOUTEILLES endommagées peuvent exploser.

Les bouteilles contiennent des gaz protecteurs sous haute pression. Des bouteilles endommagées peuvent exploser. Comme les bouteilles font normalement

partie du procédé de soudage, traitez-les avec soin.

- 1. Les bouteilles doivent être protégées contre les sources de chaleur intense, les chocs et les arcs de soudage.
- 2. Enchaînez verticalement les bouteilles à un support ou à un cadre fixe pour les empêcher de tomber ou d'être renversées.
- 3. Éloignez les bouteilles de tout circuit électrique ou de soudage.

- 4. Empêchez tout contact entre une bouteille et une électrode.
- 5. N'utilisez que des bouteilles de gaz protecteur, des détendeurs, des flexibles et des raccords conçus pour chaque application spécifique; ces matériels et les pièces connexes doivent être en bon état.
- 6. Ne mettez pas le visage devant le robinet de bouteille en l'ouvrant.
- 7. Remettez le chapeau de bouteille après utilisation.
- 8. Lisez et respectez les consignes relatives aux bouteilles de gaz comprimé et aux matériels connexes, ainsi que la publication P-1 de la CGA, énumérées dans les normes ci-dessous.

MISE EN GARDE

Les MOTEURS peuvent être dangereux.

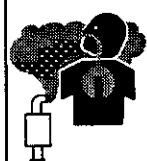

Les GAZ D'ÉCHAPPEMENT DES MOTEURS PEUVENT ÊTRE MORTELS.

Les moteurs produisent des gaz d'échappement nocifs.

- 1. Utilisez des machines à l'extérieur dans des aires ouvertes et bien ventilées.
- 2. Si vous utilisez des machines dans un endroit confiné, les fumées d'échappement doivent être envoyées à l'extérieur, loin des prises d'air du bâtiment.



Le CARBURANT peut causer un incendie ou une explosion.

Le carburant est hautement inflammable.

- 1. Arrêtez le moteur avant de vérifier le niveau de carburant ou de faire le plein.
- 2. Ne faites pas le plein en fumant ou proche d'une source

- d'étincelles ou d'une flamme nue.
- 3. Si c'est possible, laissez le moteur refroidir avant de faire le plein de carburant ou d'en vérifier le niveau au début du soudage.
- 4. Ne faites pas le plein de carburant à ras bord : prévoyez de l'espace pour son expansion.
- 5. Faites attention de ne pas renverser de carburant. Nettoyez tout carburant renversé avant de faire démarrer le moteur.



Des PIÈCES EN MOUVEMENT peuvent causer des blessures.

Des pièces en mouvement, telles des ventilateurs, des rotors et des courroies peuvent couper les doigts et les mains, ou accrocher des vêtements amples.

- 1. Assurez-vous que les portes, les panneaux, les capots et les protecteurs sont bien fermés.
- 2. Avant d'installer ou de connecter un système, arrêtez-en le moteur.
- 3. Seules des personnes qualifiées doivent démonter des

- protecteurs ou des capots pour faire l'entretien ou le dépannage nécessaire.
- 4. Pour empêcher un démarrage accidentel d'un système pendant l'entretien, débranchez le câble d'accumulateur à la borne négative.
- 5. N'approchez pas les mains ou les cheveux de pièces en mouvement; elles peuvent aussi accrocher des vêtements amples et des outils.
- 6. Réinstallez les capots ou les protecteurs et fermez les portes après des travaux d'entretien et avant de faire démarrer le moteur.

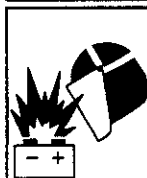

Des ÉTINCELLES peuvent FAIRE EXPLOSER UN ACCUMULATEUR; L'ÉLECTROLYTE D'UN ACCUMULATEUR peut brûler la peau et les yeux.

Les accumulateurs contiennent de l'électrolyte et dégagent des vapeurs explosives.

- 1. Portez toujours un écran facial en travaillant sur

- un accumulateur.
- 2. Arrêtez le moteur avant de connecter ou de déconnecter des câbles d'accumulateur.
- 3. N'utilisez que des outils anti-étincelles pour travailler sur un accumulateur.
- 4. N'utilisez pas un poste de soudage pour charger un accumulateur ou connecter provisoirement un véhicule.
- 5. Utilisez la polarité correcte (+ et -) de l'accumulateur.



La VAPEUR ET LE LIQUIDE DE REFROIDISSEMENT BRÛLANT SOUS PRESSION peuvent brûler la peau et les yeux.

Le liquide de refroidissement d'un radiateur peut être brûlant et sous pression.

- 1. N'ôtez pas le bouchon de radiateur tant que le moteur n'a pas refroidi.
- 2. Mettez des gants et posez un torchon sur le bouchon pour l'ôter.
- 3. Laissez la pression s'échapper avant d'ôter complètement le bouchon.

PRINCIPALES NORMES DE SÉCURITÉ

Safety in Welding and Cutting, norme ANSI Z49.1, American Welding Society, 550, N.W. LeJeune Rd., Miami FL 33128.

Safety and Health Standards, OSHA 29 CFR 1910, Superintendent of Documents, U.S. Government Printing Office, Washington D.C. 20402.

Recommended Safe Practices For the Preparation For Welding and Cutting of Containers That Have Held Hazardous Substances, norme AWS F4.1, American Welding Society, 550, N.W. LeJeune Rd., Miami FL 33128.

National Electrical Code, norme 70 NFPA, National Fire Protection Association, Batterymarch Park, Quincy, MA 02269.

Safe Handling of Compressed Gases in Cylinders, document P-1, Compressed Gas Association, 1235 Jefferson Davis Highway, Suite 501, Arlington, Va 22202.

Code for Safety in Welding and Cutting, norme CSA W117.2, Association canadienne de normalisation, Standards Sales, 176 Rexdale Boulevard, Rexdale, Ontario, Canada M9W 1R3.

Safe Practices for Occupation and Educational Eye and Face Protection, norme ANSI Z87.1, American National Standards Institute, 1430 Broadway, New York, NY 10018.

Cutting and Welding Processes, norme 51B NFPA, National Fire Protection Association, Batterymarch Park, Quincy, MA 02269.

TABLE OF CONTENTS

SECTION 1 – SAFETY INFORMATION	1
SECTION 2 – SPECIFICATIONS	
2-1. Volt-Ampere Curves	2
2-2. Duty Cycle	2
SECTION 3 – INSTALLATION	
3-1. Typical Process Connections	3
3-2. Selecting A Location And Moving Welding Power Source	3
3-3. Selecting And Preparing Weld Output Cables	4
3-4. Lower Front Panel	5
3-5. Connecting To Weld Output Terminals	5
3-6. Remote 14 Receptacle Information And Connections	6
3-7. 115 Volts AC Duplex Receptacle	6
3-8. Shielding Gas Connections	7
3-9. Connecting Input Power	8
SECTION 4 – OPERATION	10
SECTION 5 – MAINTENANCE & TROUBLESHOOTING	
5-1. Routine Maintenance	18
5-2. Overload Protection	18
5-3. Adjusting Spark Gaps	19
5-4. Setting Preflow Function For Spot Weld Timer Option	20
5-5. Troubleshooting	21
SECTION 6 – ELECTRICAL DIAGRAMS	23
SECTION 7 – HIGH FREQUENCY	26
SECTION 8 – TUNGSTEN ELECTRODE	
8-1. Selecting Tungsten Electrode	28
8-2. Preparing Tungsten	29
SECTION 9 – PARTS LIST	
Figure 9-1. Main Assembly	30
Figure 9-2. Panel, Front w/Components	32
Figure 9-3. Switch, Push Button	34
Figure 9-4. Terminal Assembly, Primary	34
Figure 9-5. Panel, Rear w/Components	35
Figure 9-6. HF Panel	36
Optional Equipment	38

SECTION 1 – SAFETY INFORMATION

mod1.1 8/92

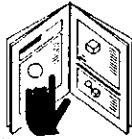

- Read all safety messages throughout this manual.
- Obey all safety messages to avoid injury.
- Learn the meaning of WARNING and CAUTION.

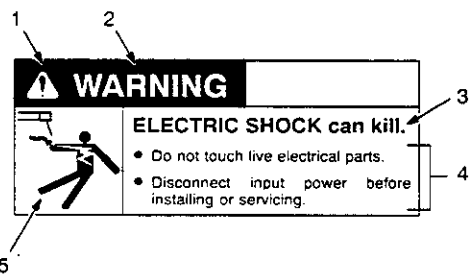

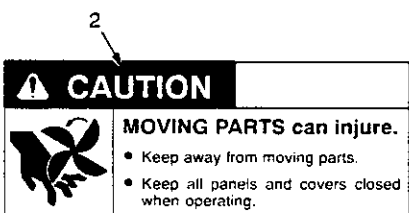



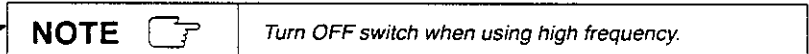

- 1 Safety Alert Symbol
- 2 Signal Word

WARNING means possible death or serious injury can happen.

CAUTION means possible minor injury or equipment damage can happen.

- 3 Statement Of Hazard And Result
- 4 Safety Instructions To Avoid Hazard
- 5 Hazard Symbol (If Available)
- 6 Safety Banner

Read safety blocks for each symbol shown.

- 7 NOTE

Special instructions for best operation – not related to safety.

Figure 1-1. Safety Information

SECTION 2 – SPECIFICATIONS

Table 2-1. Welding Power Source

Specification	Description			
Type Of Output	Direct Current/Constant Current (DC/CC) Or Alternating Current/Constant Current (AC/CC)			
Rated Weld Output	300 Amperes, 32 Volts At 60% Duty Cycle (See Section 2-2)			
Type Of Input Power	Single-Phase; 200, 230, 460, Or 575 Volts AC; 60 Hz			
Input Amperes At Rated Output	106 A At 200 V, 92 A At 230 V, 46 A At 460 V, 36.8 A At 575 V			
KVA/KW Used At Rated Output	21.2 kVA/16 kW			
Max. Open-Circuit Voltage	80 V, AC Or DC Mode			
Welding Processes	Gas Tungsten Arc (GTAW) And Shielded Metal Arc (SMAW) Welding			
Overall Dimensions	See Figure 3-3			
Weight	Net: 750 lb (340 kg); Ship: 775 lb (351 kg)			
Options	See Rear Cover			
Welding Ranges	AC GTAW	AC SMAW	DC GTAW	DC SMAW
	5-55 A	5-50 A	5-60 A	5-45 A
	20-280 A	20-265 A	20-280 A	18-235 A
	50-450 A	40-420 A	45-450 A	35-370 A

2-1. Volt-Ampere Curves

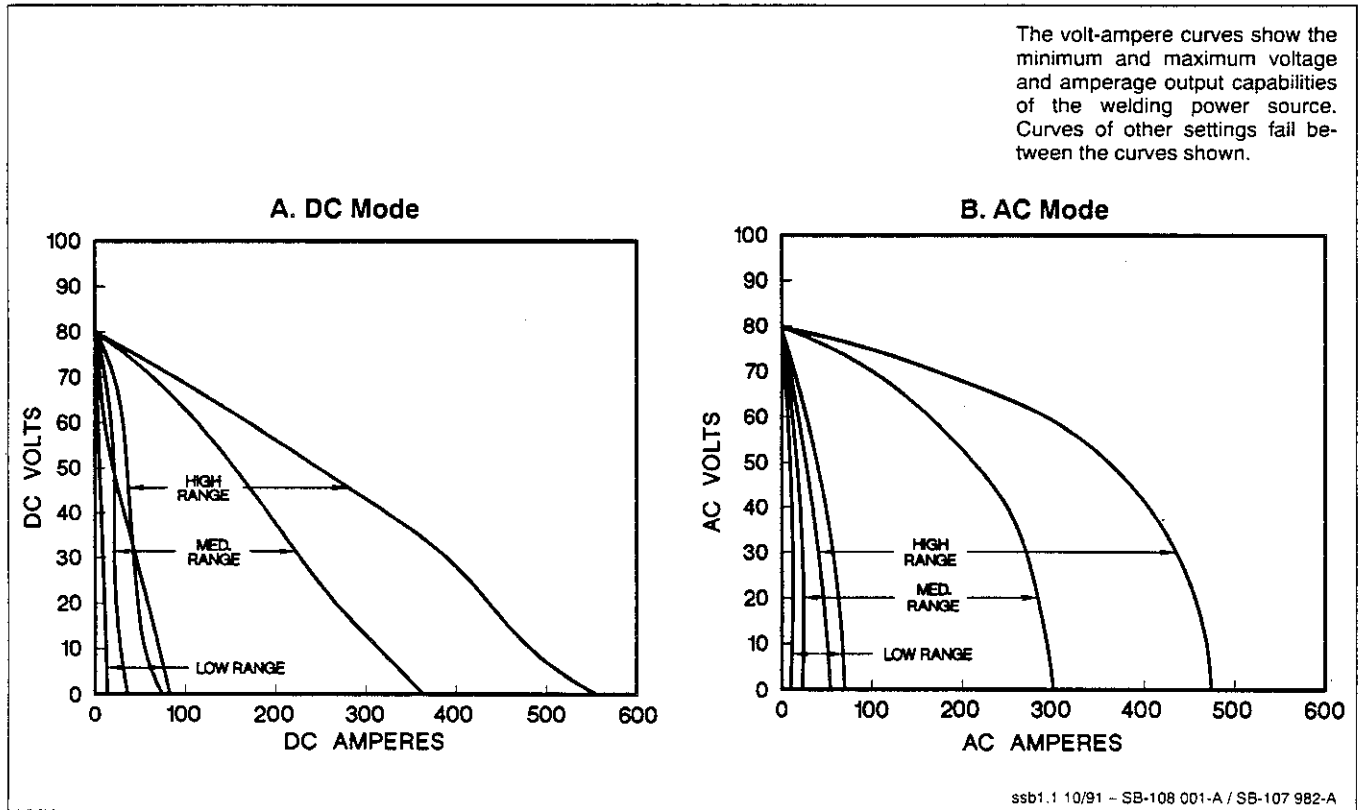

Figure 2-1. Volt-Ampere Curves

2-2. Duty Cycle

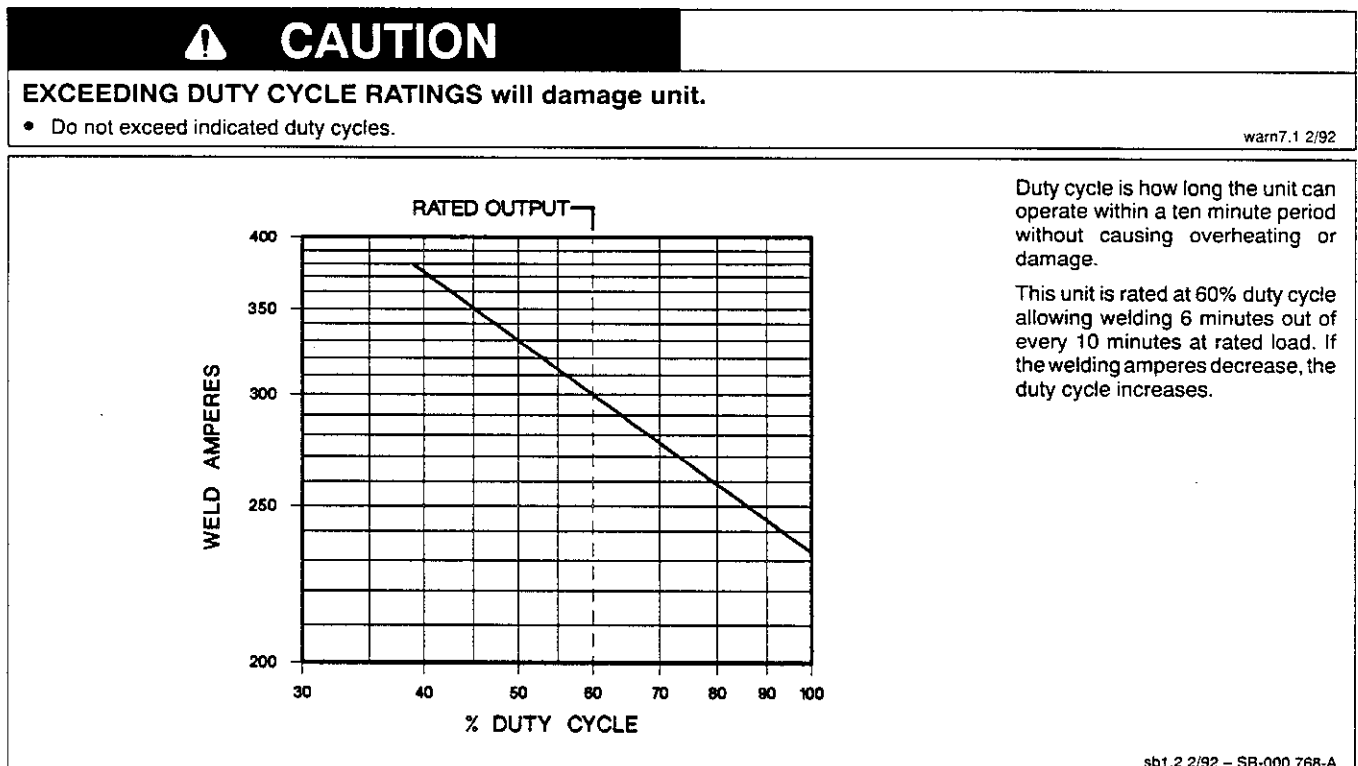
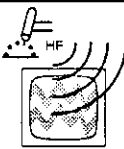

Figure 2-2. Duty Cycle Chart

SECTION 3 – INSTALLATION

⚠ WARNING	
	<p>HIGH-FREQUENCY RADIATION can interfere with radionavigation, safety services, computers, and communications equipment.</p> <ul style="list-style-type: none"> • Have only qualified person familiar with electronic equipment perform this installation. • Read and follow entire Section 7 for proper location and installation requirements for high-frequency equipment before installing unit.

3-1. Typical Process Connections

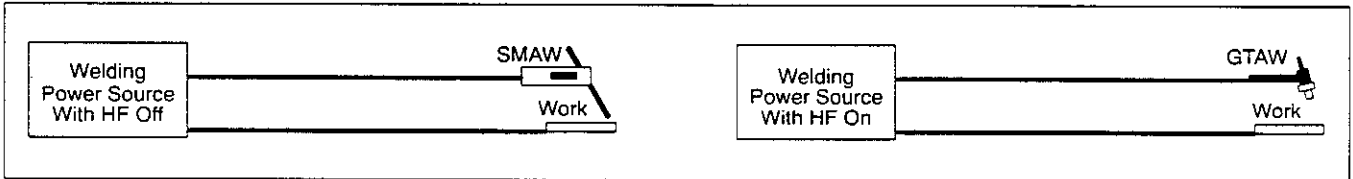



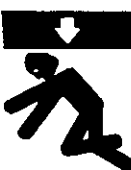

Figure 3-1. Typical Process Connections

3-2. Selecting A Location And Moving Welding Power Source

⚠ WARNING		
	<p>ELECTRIC SHOCK can kill.</p> <ul style="list-style-type: none"> • Do not touch live electrical parts. • Disconnect input power conductors from deenergized supply line BEFORE moving welding power source. 	
	<p>FIRE OR EXPLOSION can result from placing unit on, over, or near combustible surfaces.</p> <ul style="list-style-type: none"> • Do not locate unit on, over, or near combustible surfaces. • Do not install unit near flammables. 	
	<p>BLOCKED AIRFLOW causes overheating and possible damage to unit.</p> <ul style="list-style-type: none"> • Do not block or filter airflow. <p>Warranty is void if any type of filter is used.</p>	
		<p>FUMES can be hazardous; LACK OF FRESH AIR AND PROPER VENTILATION can be harmful.</p> <ul style="list-style-type: none"> • Do not breathe welding fumes. • Place unit only where there is a good fresh air supply and proper ventilation. <p>FALLING EQUIPMENT can cause serious personal injury and equipment damage.</p> <ul style="list-style-type: none"> • Use lifting eye to lift unit only, NOT running gear, gas cylinders, or any other accessories. • Use equipment of adequate capacity to lift the unit.
		<small>swam11.1 2/92</small>

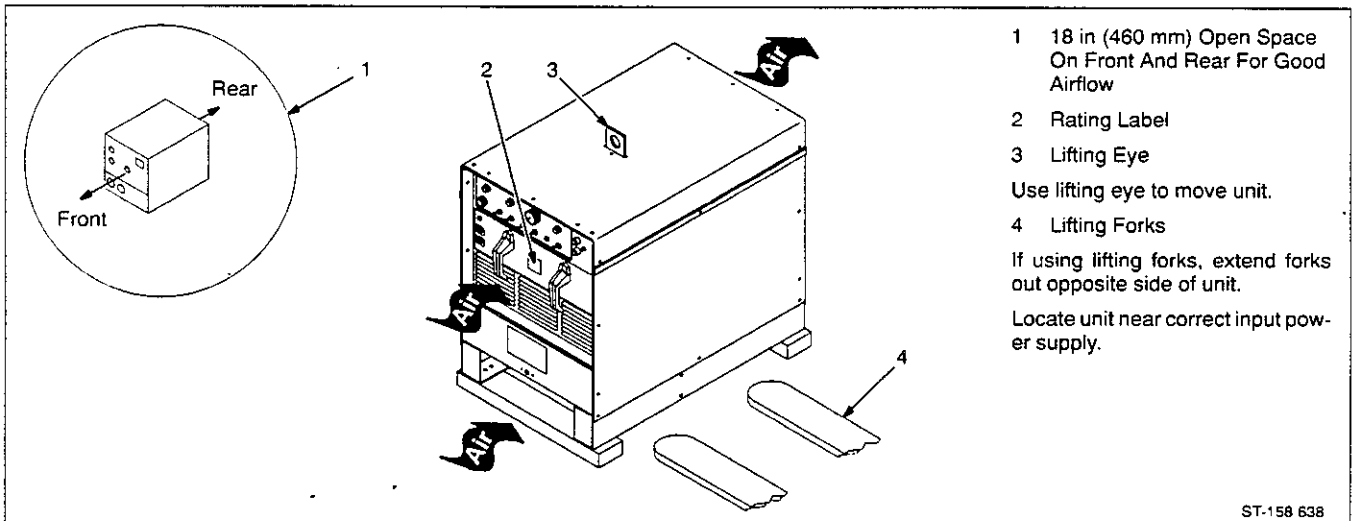
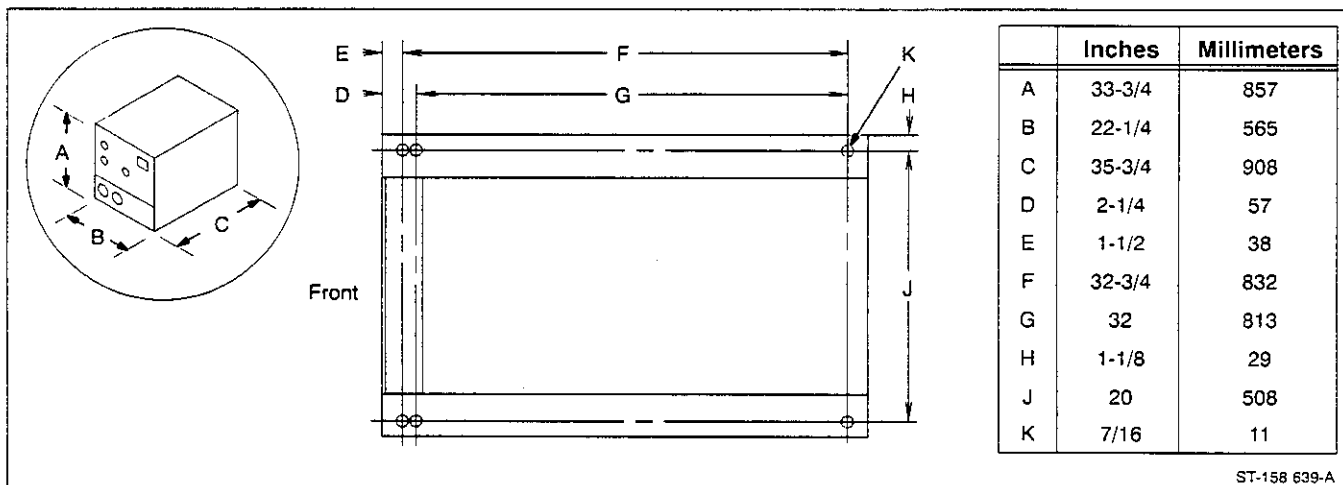

Figure 3-2. Location and Movement Of Welding Power Source



ST-158 639-A

Figure 3-3. Overall Dimensions And Base Mounting Hole Layout

3-3. Selecting And Preparing Weld Output Cables

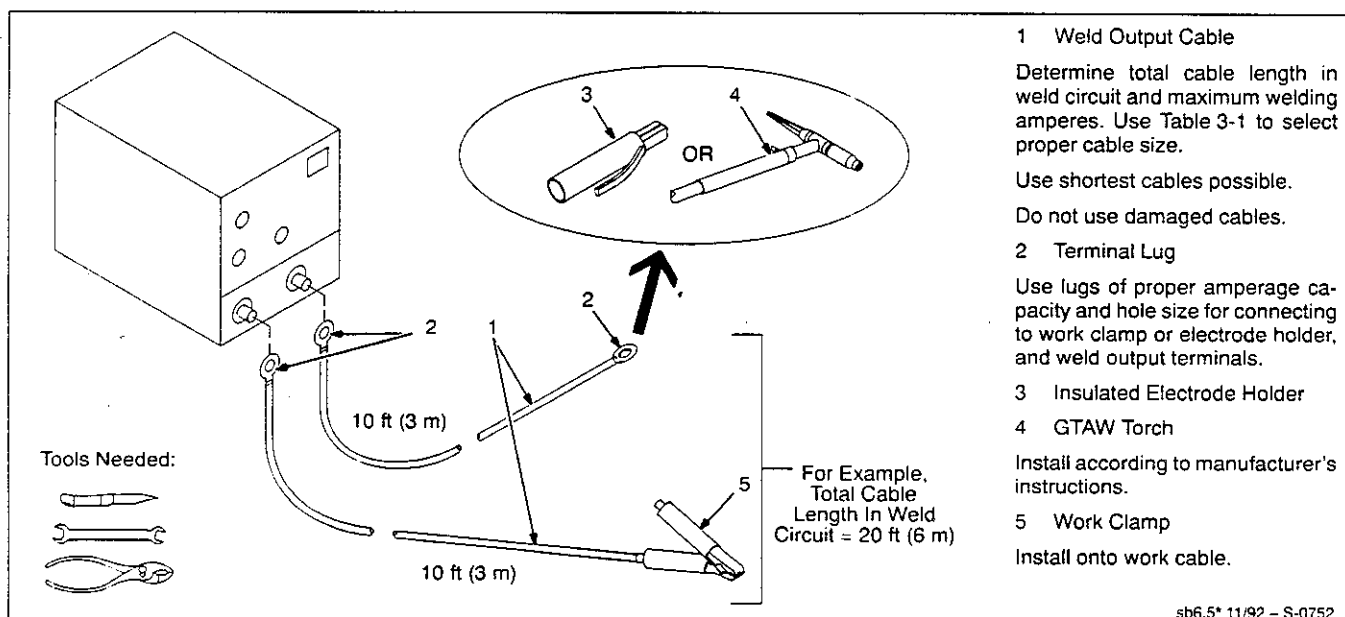

sb6.5* 11/92 - S-0752

Figure 3-4. Selecting And Preparing Weld Output Cables

Table 3-1. Weld Cable Size*

Welding Amperes	Total Cable (Copper) Length In Weld Circuit Not Exceeding							
	100 ft (30 m) Or Less		150 ft (45 m)	200 ft (60 m)	250 ft (70 m)	300 ft (90 m)	350 ft (105 m)	400 ft (120 m)
	10 To 60% Duty Cycle	60 Thru 100% Duty Cycle	10 Thru 100% Duty Cycle					
100	4	4	4	3	2	1	1/0	1/0
150	3	3	2	1	1/0	2/0	3/0	3/0
200	3	2	1	1/0	2/0	3/0	4/0	4/0
250	2	1	1/0	2/0	3/0	4/0	2-2/0	2-2/0
300	1	1/0	2/0	3/0	4/0	2-2/0	2-3/0	2-3/0
350	1/0	2/0	3/0	4/0	2-2/0	2-3/0	2-3/0	2-4/0
400	1/0	2/0	3/0	4/0	2-2/0	2-3/0	2-4/0	2-4/0
500	2/0	3/0	4/0	2-2/0	2-3/0	2-4/0	3-3/0	3-3/0

*Weld cable size (AWG) is based on either a 4 volts or less drop or a current density of not more than 300 circular mils per ampere.

S-0007-C

3-4. Lower Front Panel

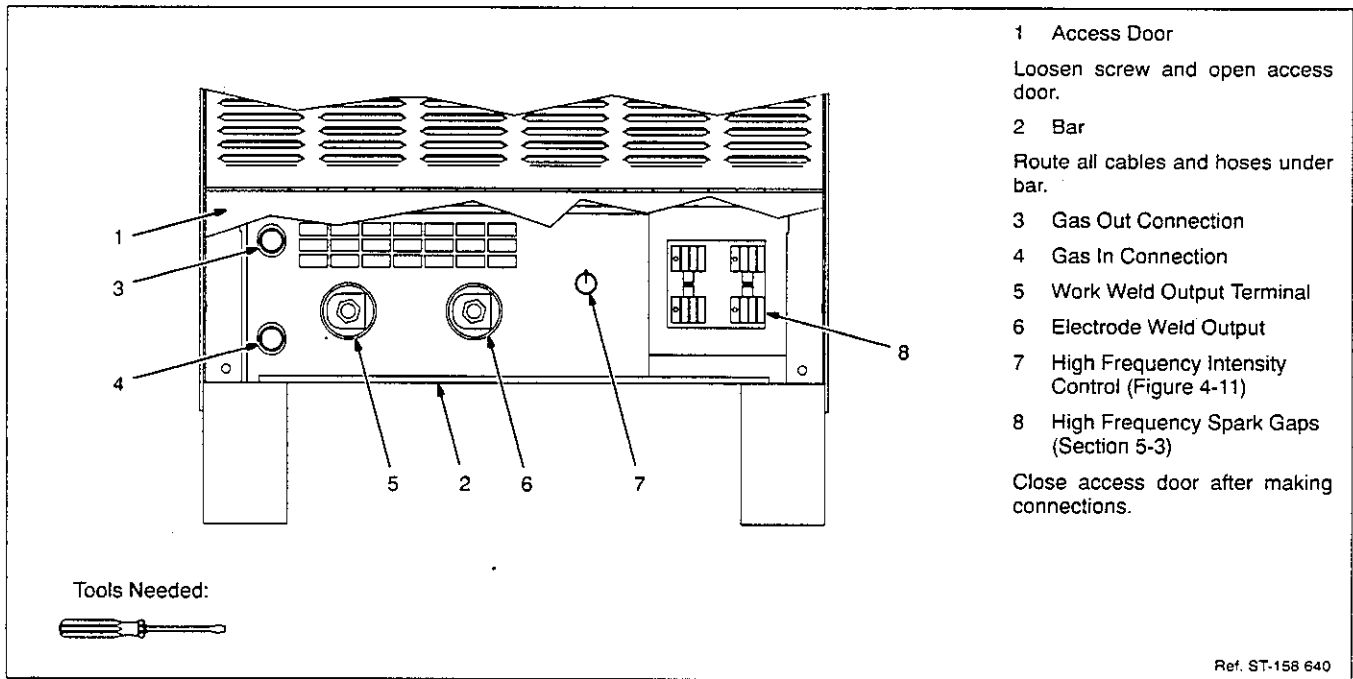

Figure 3-5. Lower Front Panel

3-5. Connecting To Weld Output Terminals

⚠ WARNING

ELECTRIC SHOCK can kill.

- Do not touch live electrical parts.
- Turn Off welding power source, and disconnect input power before making any weld output connections.

swarn12.1 2/92

1 Work Weld Output Terminal
For both GTAW and SMAW welding, connect one end of work cable to Work weld output terminal and remaining end to workpiece.

2 Electrode Weld Output Terminal
For GTAW welding, connect torch connector or cable to Electrode weld output terminal. Be sure torch connector does not touch access door when closed.
For SMAW welding, connect electrode holder cable to Electrode weld output terminal.

Weld output polarity is determined by position of the Output Selector switch (see Figure 4-4).

Close access door.

Tools Needed:
 3/4 in

Figure 3-6. Weld Output Connections

3-6. Remote 14 Receptacle Information And Connections

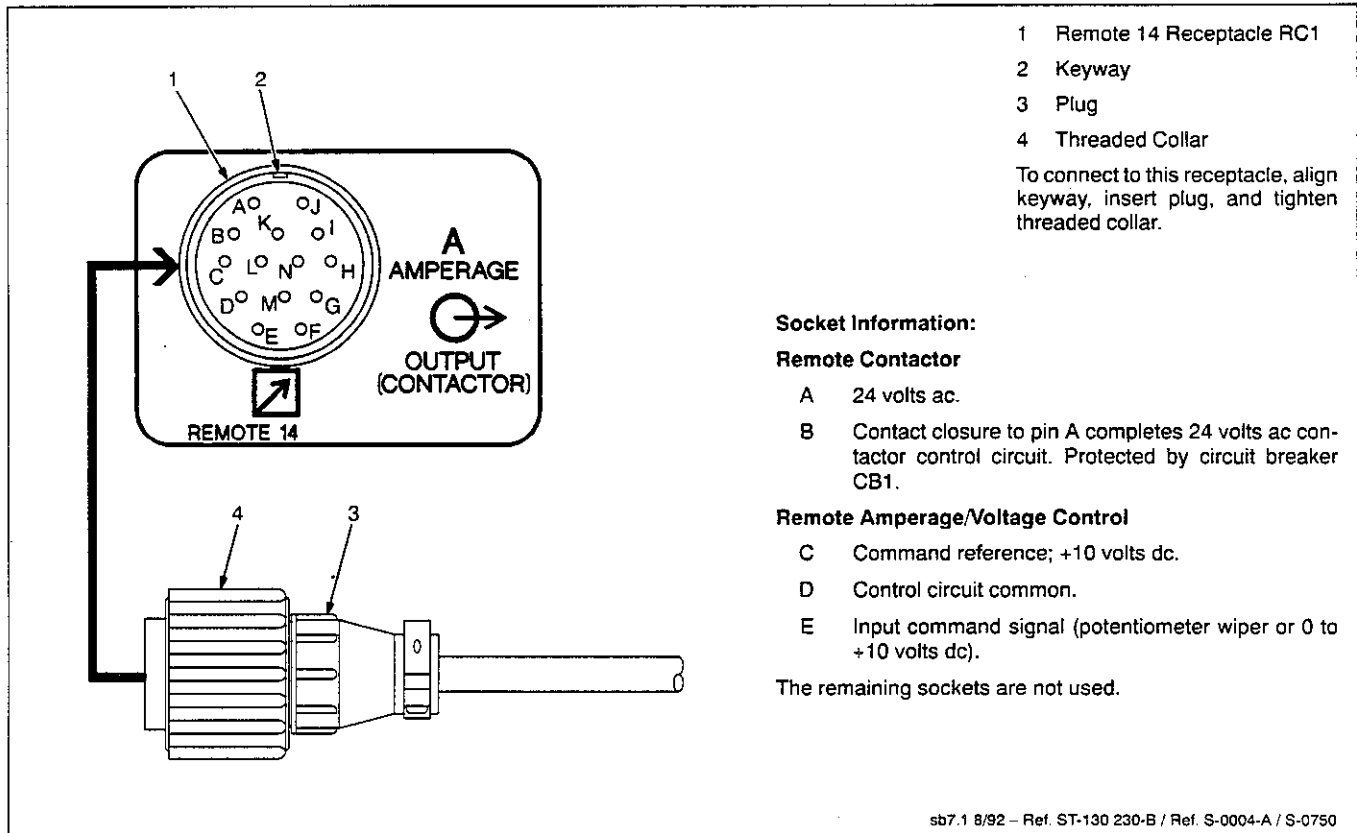

Figure 3-7. Remote 14 Connections

3-7. 115 Volts AC Duplex Receptacle

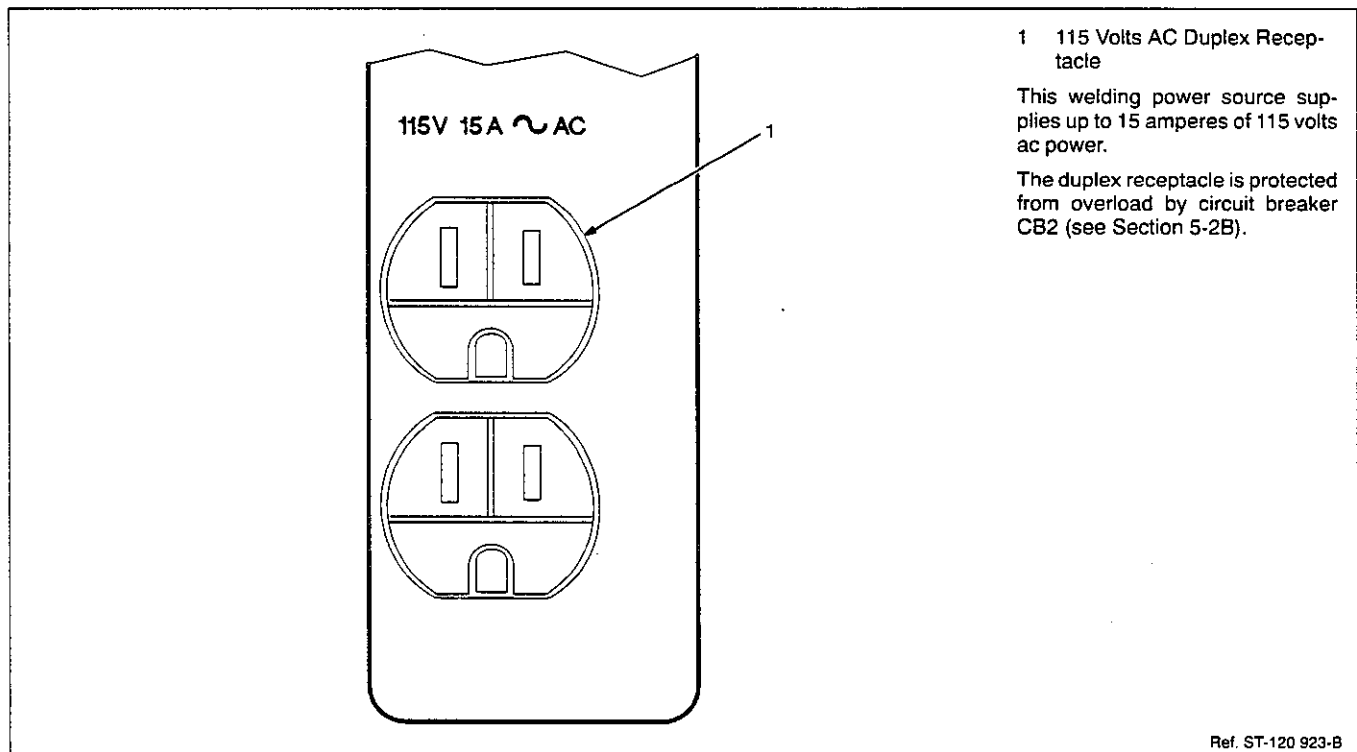



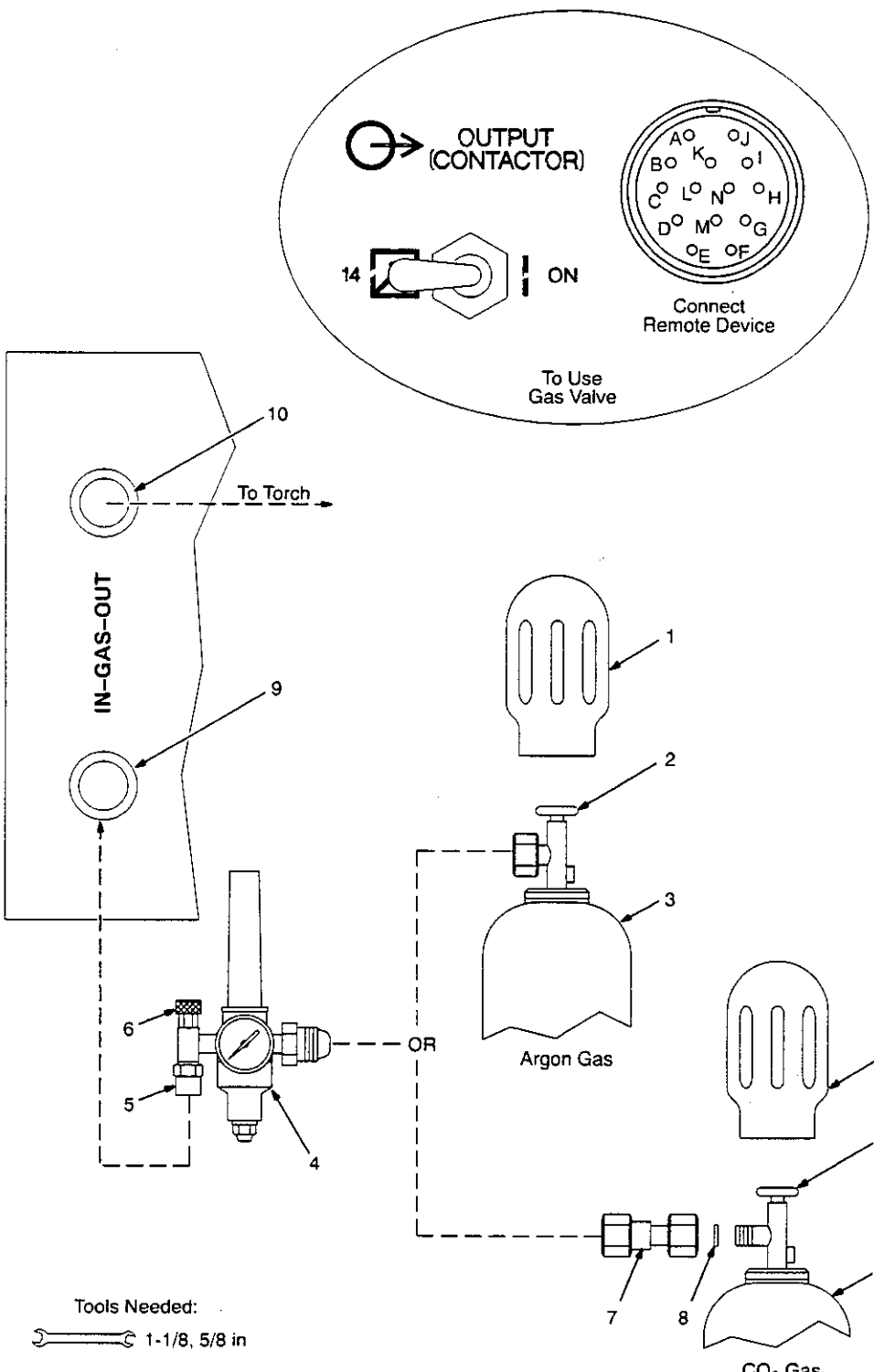

Figure 3-8. Connecting To 115 Volts AC Duplex Receptacle

3-8. Shielding Gas Connections

	<h2 style="margin: 0;">WARNING</h2>	
	<p>CYLINDERS can explode if damaged.</p> <ul style="list-style-type: none"> • Keep cylinders away from welding and other electrical circuits. • Never touch cylinder with welding electrode. • Always secure cylinder to running gear, wall, or other stationary support. 	 <p>BUILDUP OF SHIELDING GAS can harm health or kill.</p> <ul style="list-style-type: none"> • Shut off shielding gas supply when not in use.
warn4.1 9/91		



To Use Gas Valve

OR

Argon Gas

CO₂ Gas

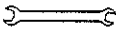
Tools Needed:
 1-1/8, 5/8 in

Obtain gas cylinder and chain to running gear, wall, or other stationary support so cylinder cannot fall and break off valve.

- 1 Cap
- 2 Cylinder Valve

Remove cap, stand to side of valve, and open valve slightly. Gas flow blows dust and dirt from valve. Close valve.

- 3 Cylinder
- 4 Regulator/Flowmeter

Install so face is vertical.

- 5 Gas Hose Connection

Fitting has 5/8-18 right-hand threads.

- 6 Flow Adjust

Typical flow rate is 20 cfh (cubic feet per hour). Check wire manufacturer's recommended flow rate.

- 7 CO₂ Adapter
- 8 O-Ring

Install adapter with O-ring between regulator/flowmeter and CO₂ cylinder.

- 9 Gas In Fitting
- 10 Gas Out Fitting

The Gas In and Gas Out fittings have 5/8-18 right hand threads. Obtain proper size, type, and length hose and make connections as follows:



Connect hose from shielding gas supply regulator/flowmeter to Gas In fitting.

Connect shielding gas hose from torch to Gas Out fitting.

Close access door.

Figure 3-9. Typical Regulator/Flowmeter Installation

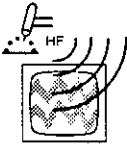
3-9. Connecting Input Power

⚠ WARNING	
 <p>HIGH-FREQUENCY RADIATION can interfere with radionavigation, safety services, computers, and communications equipment.</p> <ul style="list-style-type: none"> • Have only qualified person familiar with electronic equipment perform this installation. • Read and follow entire Section 7 for proper location and installation requirements for high-frequency equipment before installing unit. 	 <p>ELECTRIC SHOCK can kill.</p> <ul style="list-style-type: none"> • Do not touch live electrical parts. • Turn Off welding power source, and disconnect input power before inspecting or installing. • Have only qualified persons install unit. • Installation must meet National Electrical Code and all other codes.

A. Positioning Jumper Links

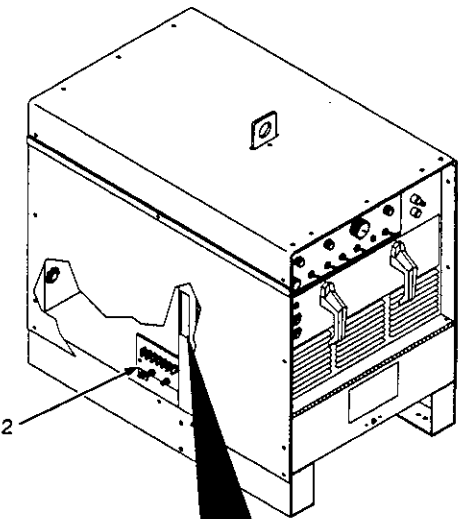

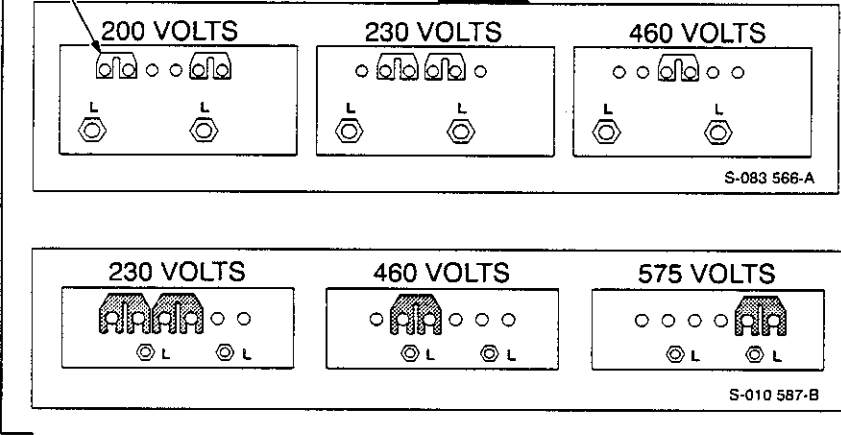

2



3

1

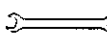
Tools Needed:

-  3/8 in
-  3/8 in

Jumper links allow operation on different input voltages and are factory set for the highest input voltage.

Check input voltage available at site.

Remove side panel to check jumper links.

- 1 Input Voltage Label – Only One Is On Unit
- 2 Input Terminal Board
- 3 Input Voltage Jumper Links

Move links to match input voltage. For example, use 230 volts position when 230 volts input power is available.

Reinstall side panel or go on to Figure 3-11.

Figure 3-10. Input Voltage Jumper Links Location

B. Connecting Input Power

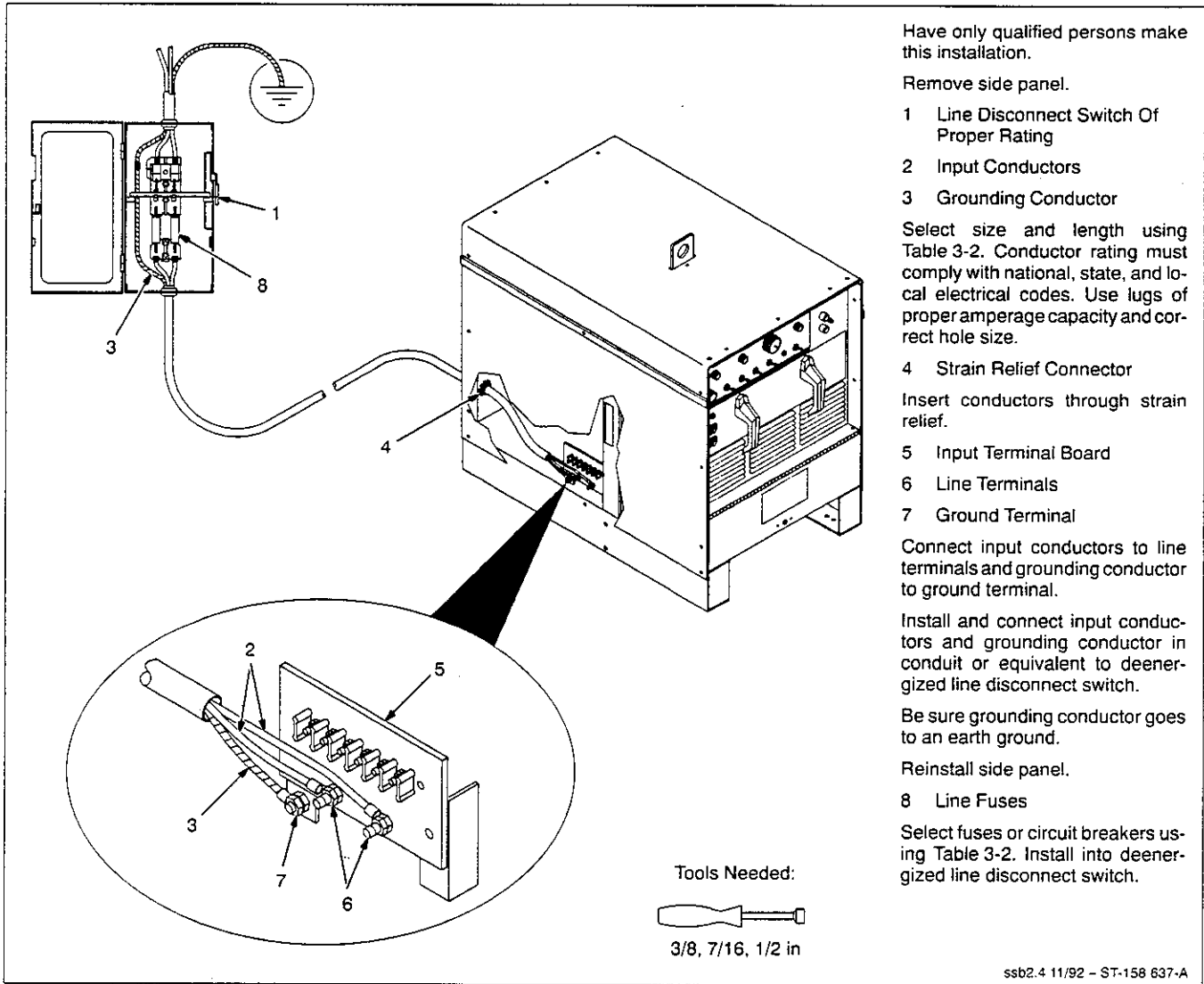

Figure 3-11. Input Power Connections

Table 3-2. Electrical Service Requirements*

Input Voltage	200	230	460	575
Input Amperes At Rated Output	106	92	46	37
Circuit Breaker Size Range In Amperes ¹	159 thru 212	138 thru 184	69 thru 92	55 thru 74
Fuse Size In Amperes ²	150	150	70	60
Input Conductor Size In AWG/Kcmil ³	4	4	8	10
Maximum Input Conductor Length In Feet (Meters) ⁴	104 (32)	137 (42)	237 (72)	247 (75)
Grounding Conductor Size In AWG/Kcmil ⁵	6	6	8	10

* These values are calculated from the 1990 edition of the National Electrical Code (NEC).

¹ Circuit breaker range is 150% to not more than 200% of rated input amperage of the welding power source (Article 630-12(a) of NEC).





² Standard fuse size is that closest to 150% of rated input amperage of the welding power source (Article 630-12(a) of NEC).

³ Input conductor size is for insulated copper wire with 75°C rating with not more than three single current-carrying conductors in a cable or raceway (Table 310-16 of NEC).

⁴ Maximum length is to prevent more than a 3% voltage drop between service entrance and input terminals of the welding power source (Articles 210-19(a) and 215-2(b) of NEC).

⁵ The grounding conductor shall be colored or identified as specified in the NEC. Grounding conductor size for copper wire is not required to be larger than input conductor (Article 250-95 of NEC).

SECTION 4 – OPERATION

⚠ WARNING	
	<p>ELECTRIC SHOCK can kill.</p> <ul style="list-style-type: none"> • Always wear dry insulating gloves. • Insulate yourself from work and ground. • Do not touch live electrical parts. • Keep all panels and covers securely in place.
	<p>FUMES AND GASES can be hazardous to your health.</p> <ul style="list-style-type: none"> • Keep your head out of the fumes. • Ventilate area, or use breathing device. • Read Material Safety Data Sheets (MSDSs) and manufacturer's instructions for material used.
	<p>WELDING can cause fire or explosion.</p> <ul style="list-style-type: none"> • Do not weld near flammable material. • Watch for fire; keep extinguisher nearby. • Do not locate unit over combustible surfaces. • Do not weld on closed containers. • Allow work and equipment to cool before handling.
	<p>MOVING PARTS can cause injury.</p> <ul style="list-style-type: none"> • Keep away from moving parts. • Keep all doors, panels, covers, and guards closed and securely in place.
	<p>MAGNETIC FIELDS FROM HIGH CURRENTS can affect pacemaker operation.</p> <ul style="list-style-type: none"> • Pacemaker wearers keep away. • Wearers should consult their doctor before going near arc welding, gouging, or spot welding operations.
<p>See Safety Precautions at beginning of manual for basic welding safety information.</p> <p style="text-align: right;"><small>swarm6.1 10/91</small></p>	

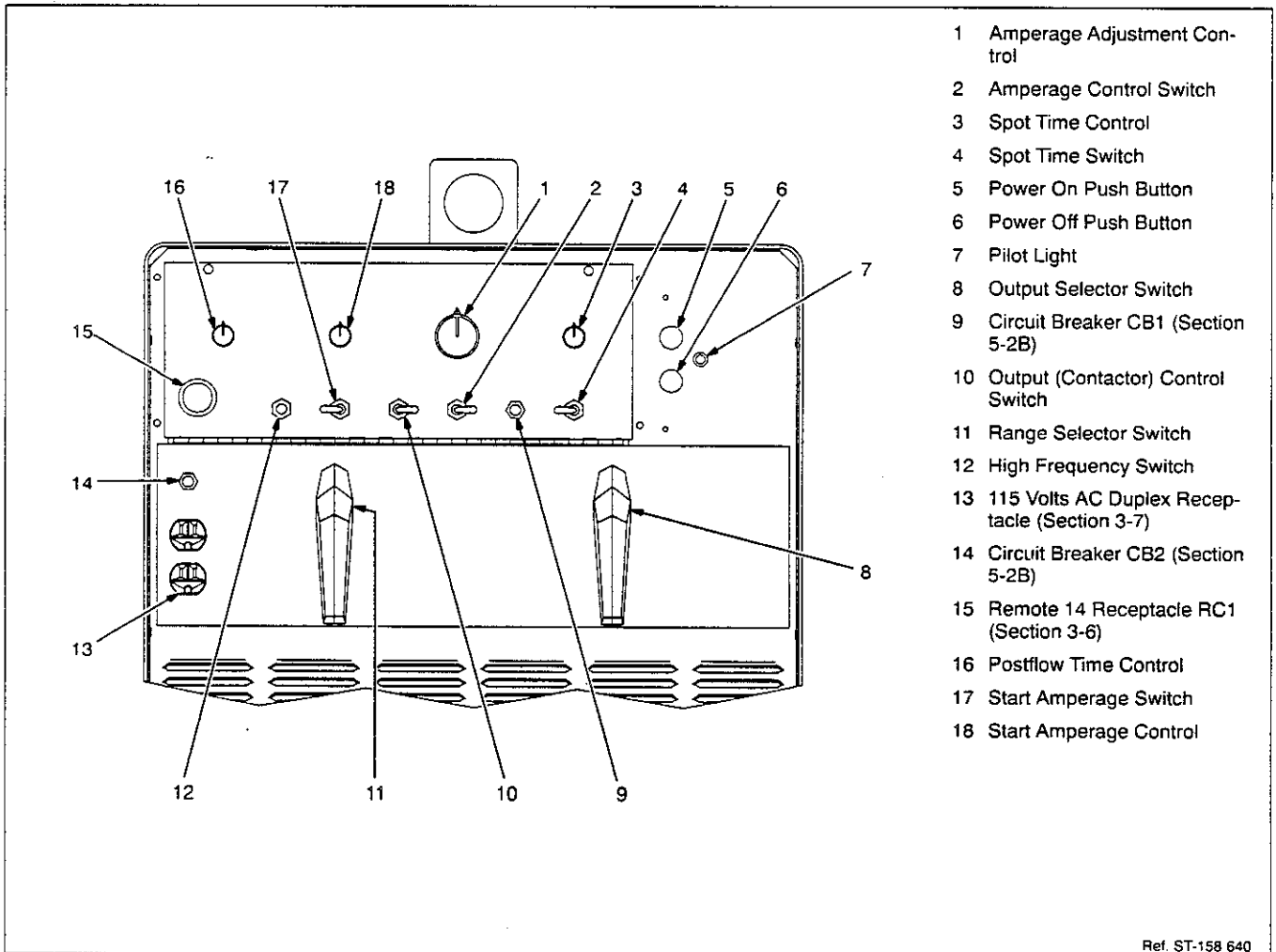

Figure 4-1. Controls

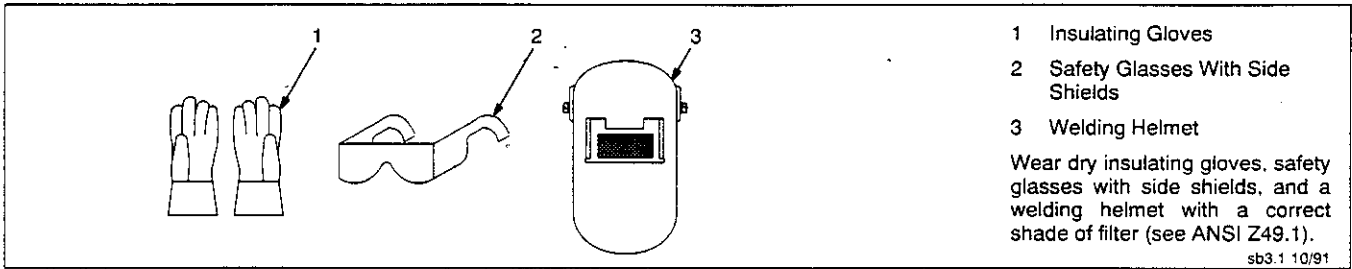

Figure 4-2. Safety Equipment

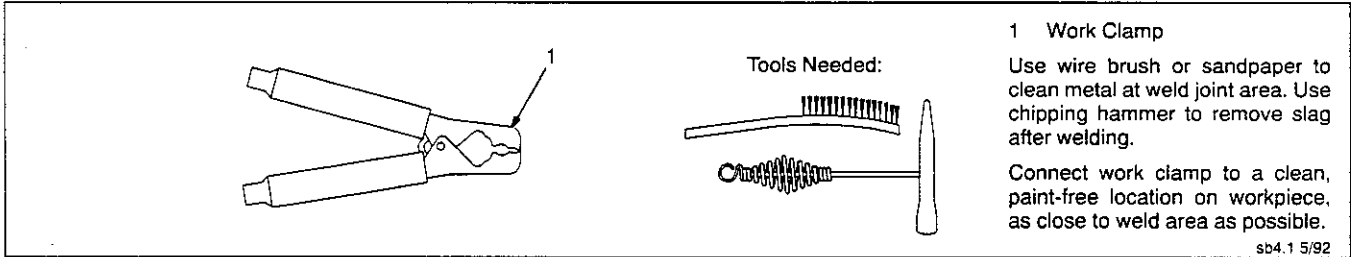



Figure 4-3. Work Clamp

⚠ WARNING	
 <p>ELECTRIC SHOCK can kill.</p> <ul style="list-style-type: none"> Do not use AC output in damp areas, if movement is confined, or if there is a danger of falling. Use AC output ONLY if required for the welding process. If AC output is required, use remote output control. Read Safety Precautions at beginning of this manual. 	<p>ARCING can damage switch.</p> <ul style="list-style-type: none"> Do not change Output Selector switch or Range Selector switch position while welding. <p>Arcing inside switch can damage contacts, causing switch to fail.</p>
<small>warn6.3 4/92 / warn5.1* 9/91</small>	

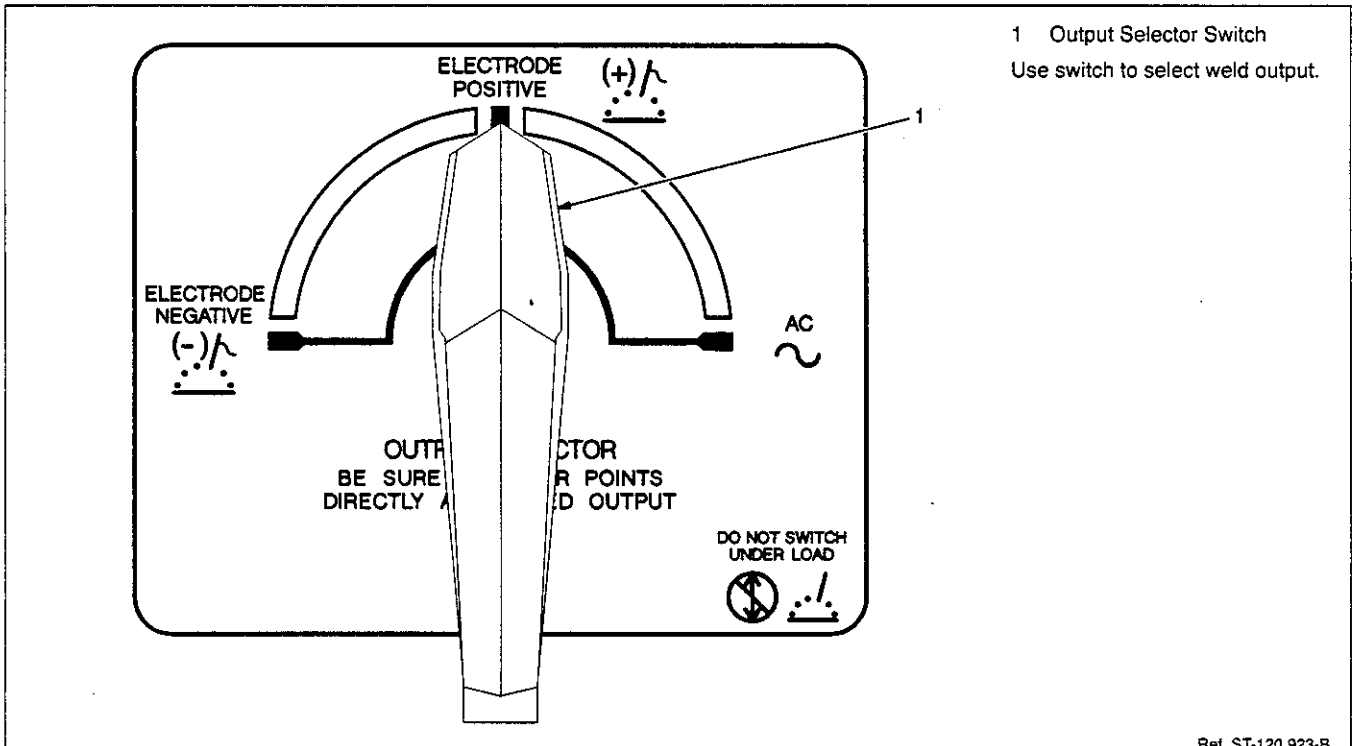

Figure 4-4. Output Selector Switch

NOTE 

Amperage ranges on the unit nameplate are for GTAW welding. See Table 2-1 for SMAW ranges.

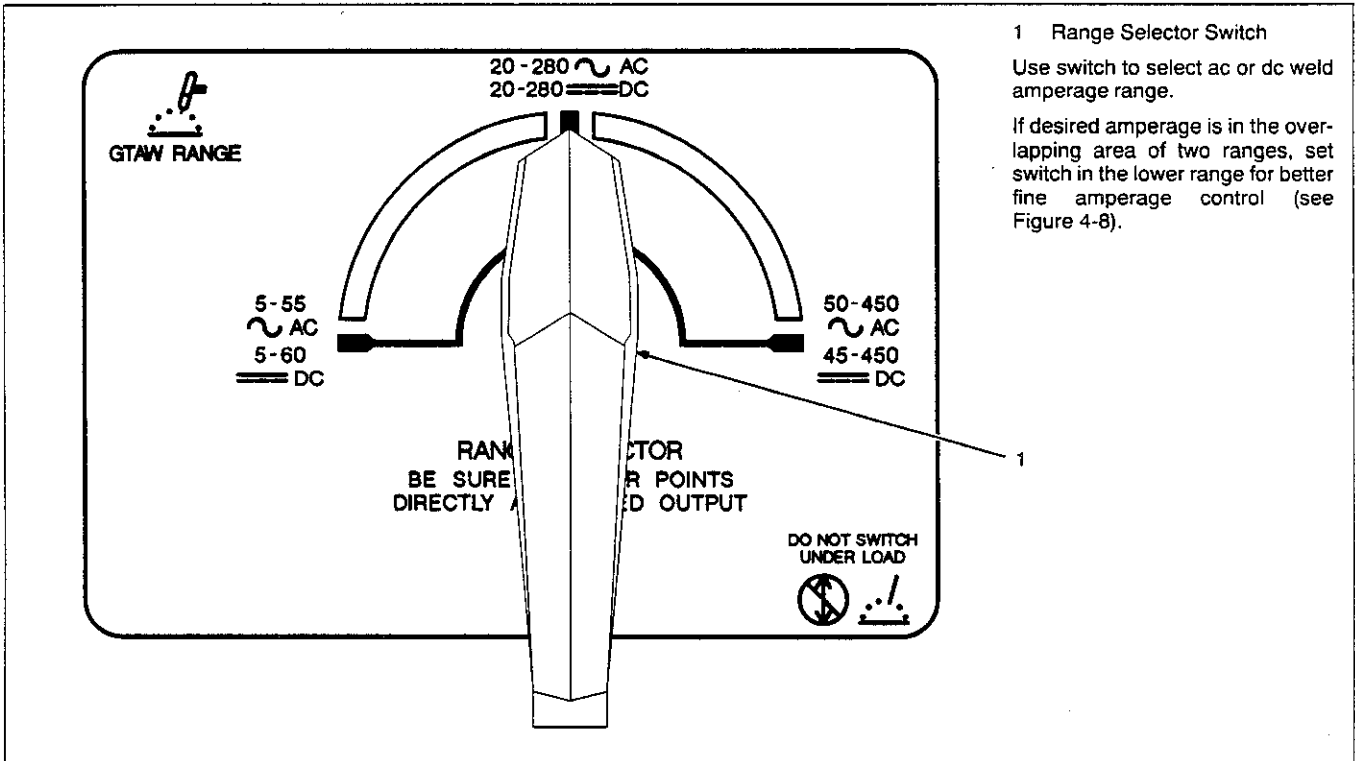

Figure 4-5. Range Selector Switch

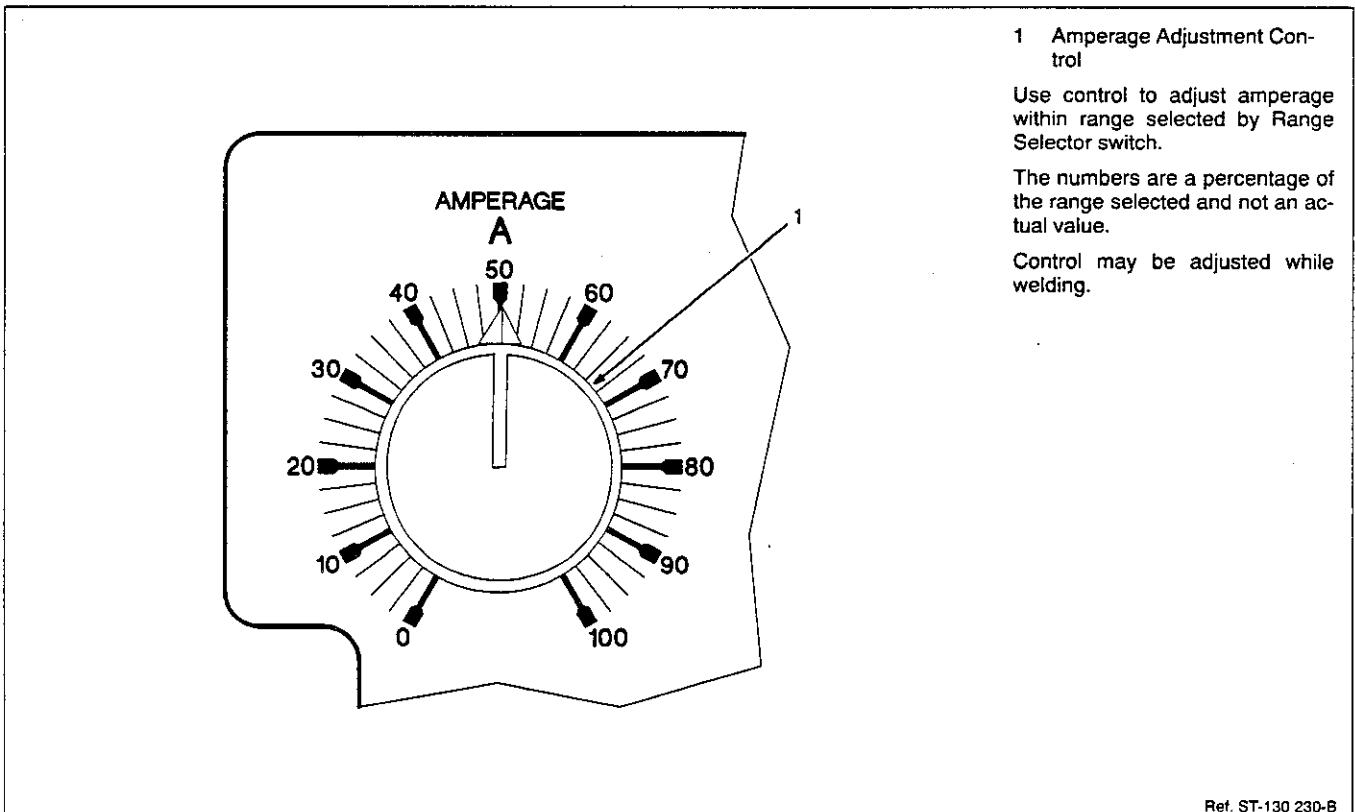

Figure 4-6. Amperage Adjustment Control

Ref. ST-130 230-B

⚠ WARNING



ELECTRIC SHOCK can kill.

- Do not touch live electrical parts.
- Do not touch weld output terminals when contactor is energized.
- Do not touch electrode and work clamp at the same time.

swam7.1 10/91

⚠ Weld output terminals are energized when switch is On and Power is On.

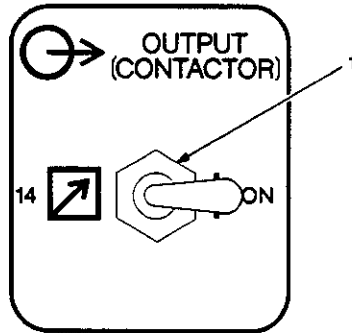

1 Output (Contactor) Control Switch

Use switch to select way of controlling unit output.

For weld output, place switch in On position.

For remote output control, place switch in Remote 14 position (see Section 3-6).

Figure 4-7. Output (Contactor) Control Switch

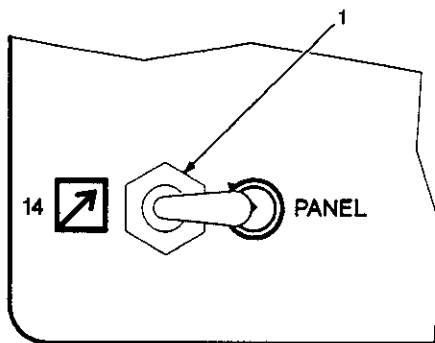

1 Amperage Control Switch

Use switch to select way of controlling amperage adjustment.

For front panel control, place switch in Panel position.

For remote control, place switch in Remote position. See Example below.

2 Remote Foot Control

3 Remote Hand Dial

4 Remote Hand Control

EXAMPLE Of Combination Remote Amperage Control

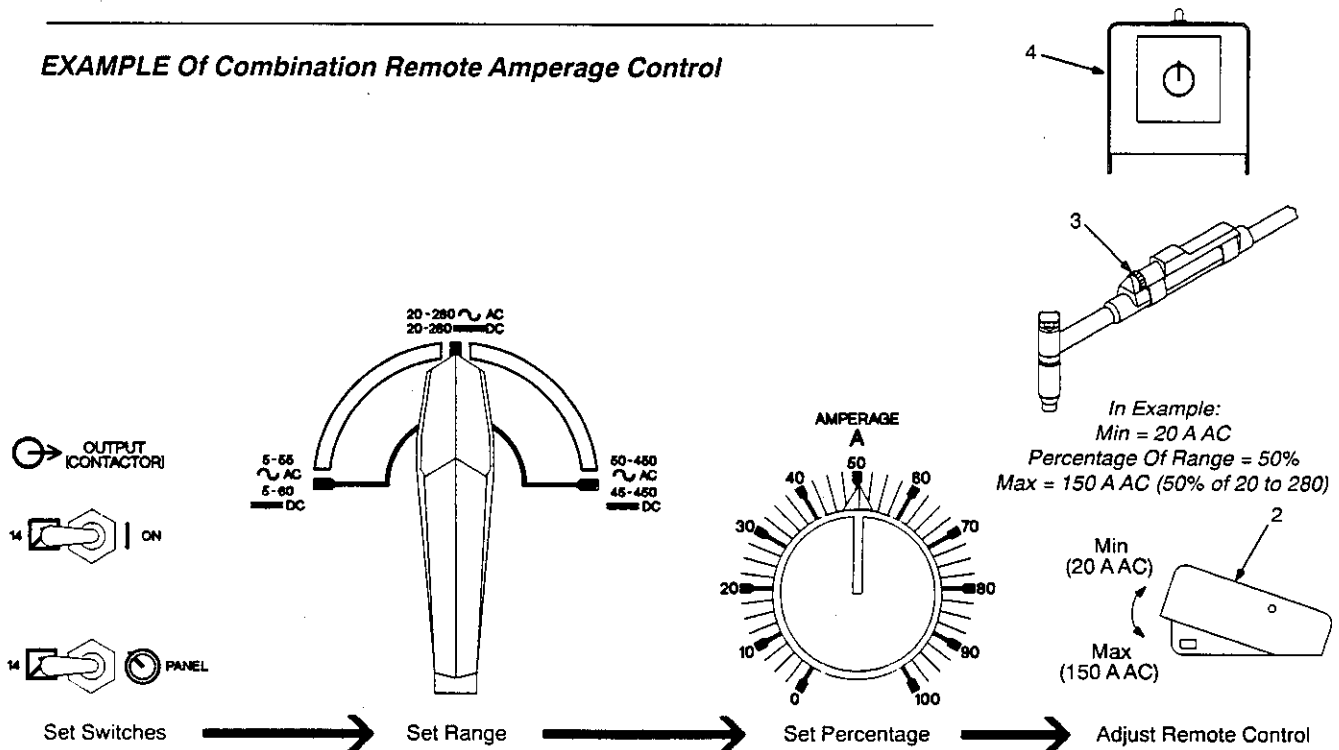

ST-159 059 / Ref. ST-120 923-B / ST-130 230-B / S-0769 / S-0774

Figure 4-8. Amperage Control Switch

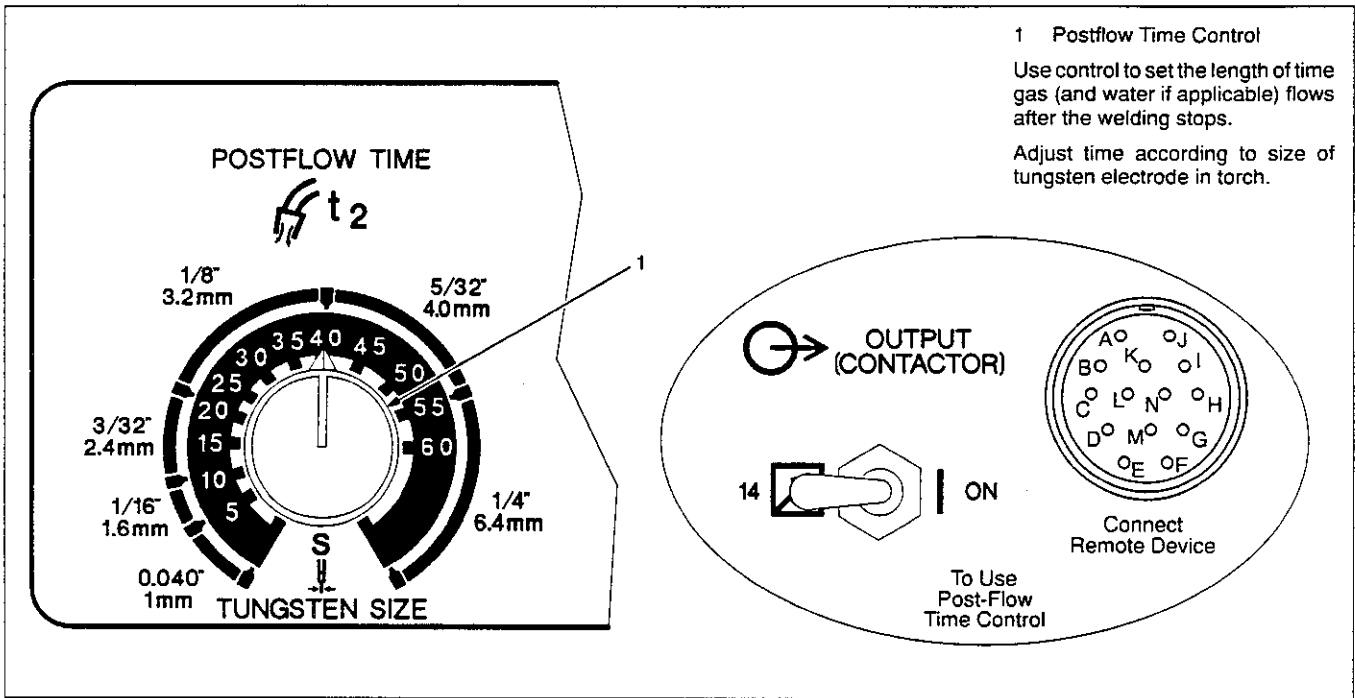

Figure 4-9. Postflow Time Control

⚠ WARNING

USING HIGH FREQUENCY WITH THE SHIELDED METAL ARC WELDING PROCESS can result in serious personal injury.

- Place the High Frequency switch in the Off position before using the Shielded Metal Arc Welding (SMAW) process.

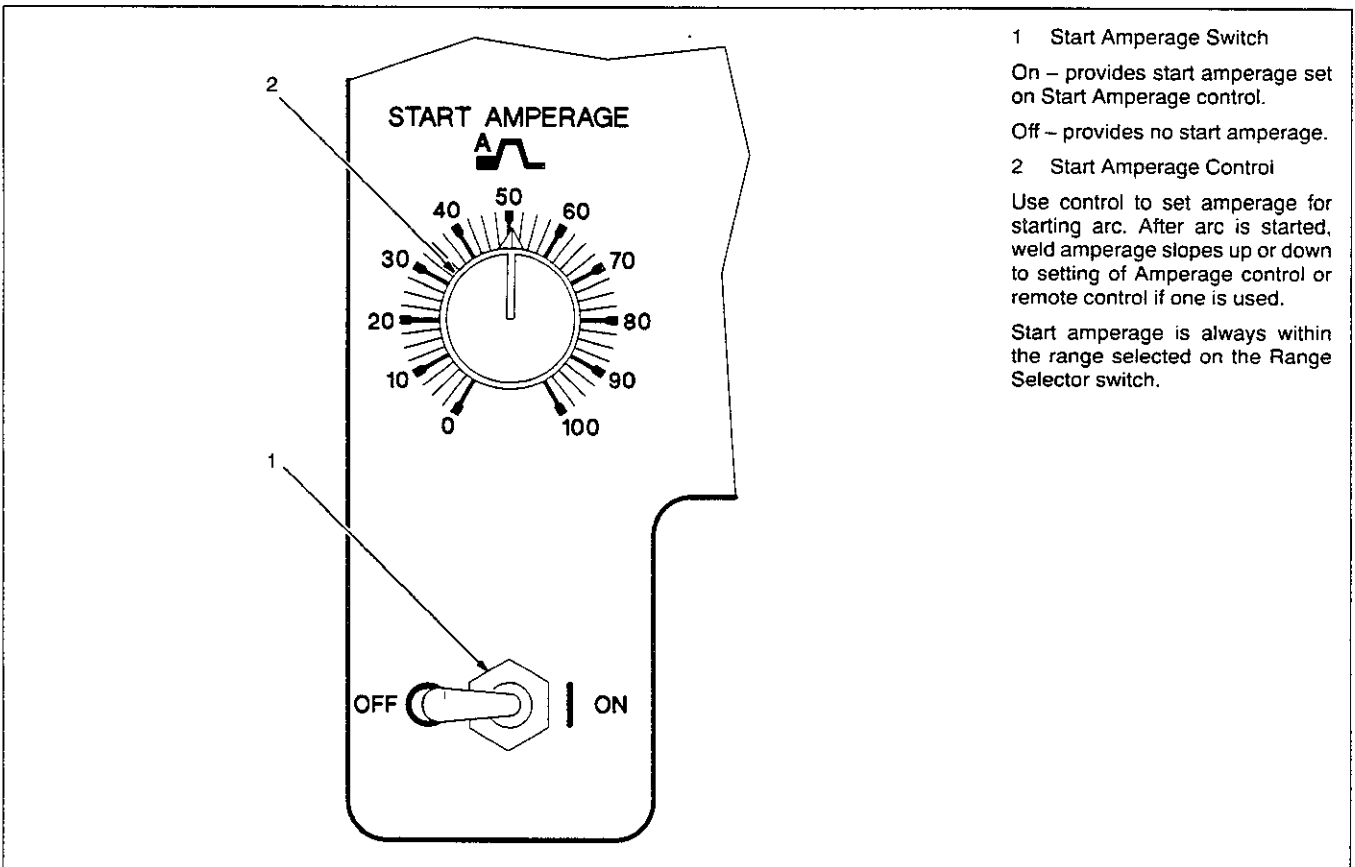

Figure 4-10. Start Amperage Controls



WARNING

USING HIGH FREQUENCY WITH THE SHIELDED METAL ARC WELDING PROCESS can result in serious personal injury.

- Place the High Frequency switch in the Off position before using the Shielded Metal Arc Welding (SMAW) Process..

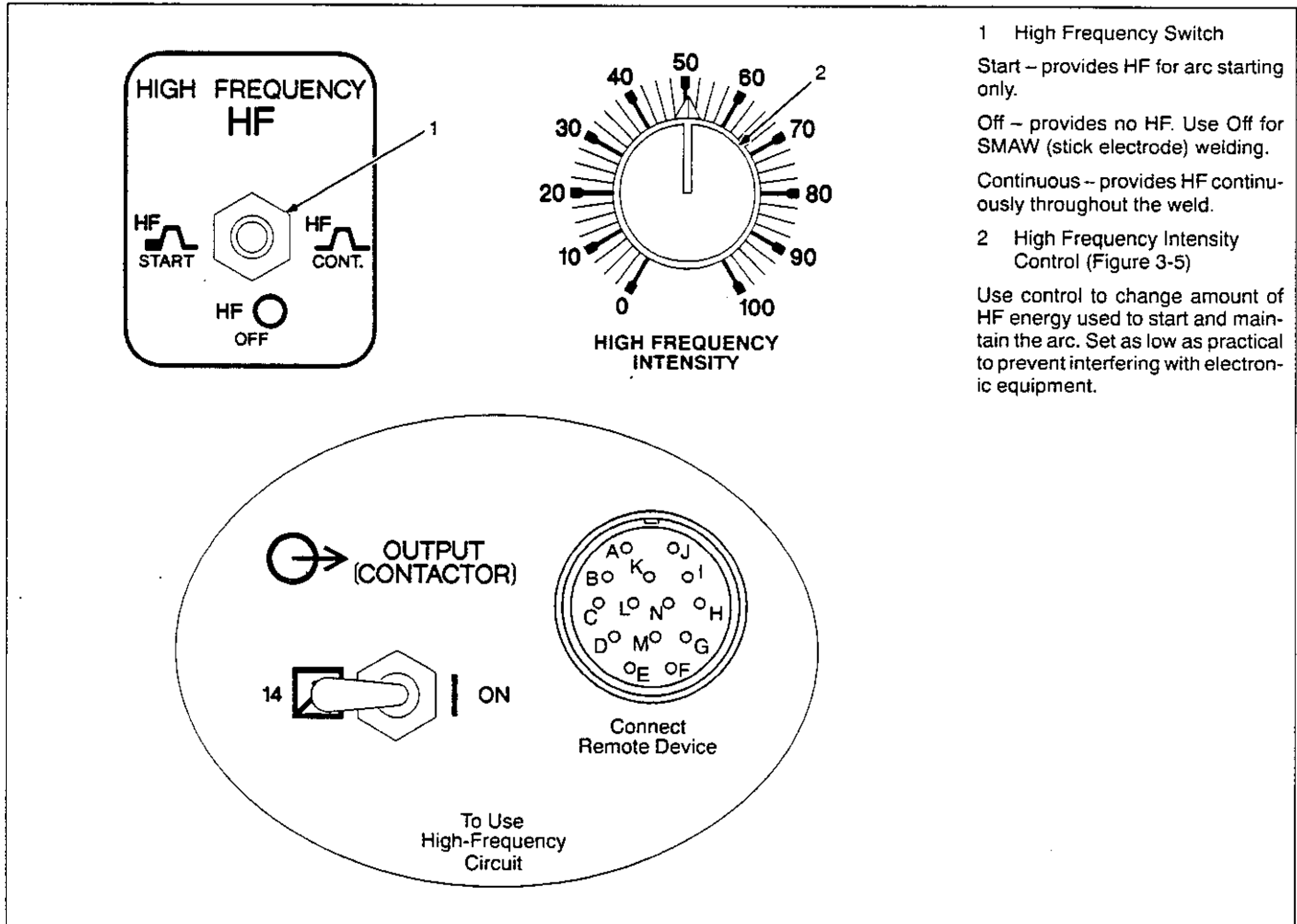

- 1 High Frequency Switch
Start – provides HF for arc starting only.
Off – provides no HF. Use Off for SMAW (stick electrode) welding.
Continuous – provides HF continuously throughout the weld.
- 2 High Frequency Intensity Control (Figure 3-5)
Use control to change amount of HF energy used to start and maintain the arc. Set as low as practical to prevent interfering with electronic equipment.

Figure 4-11. High Frequency Controls

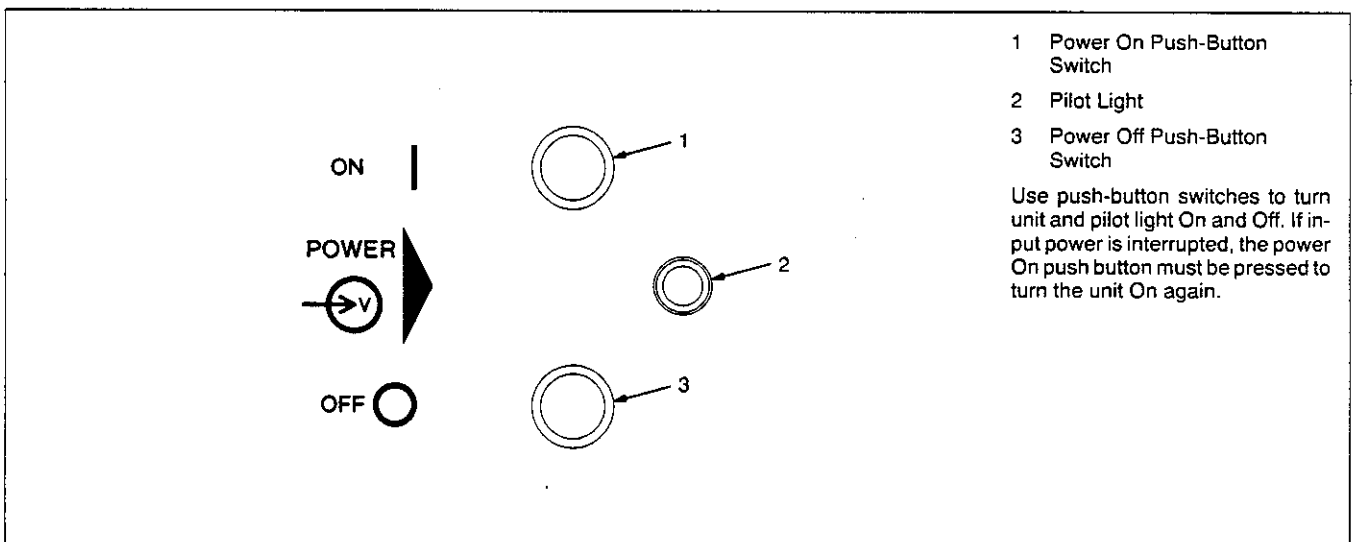

- 1 Power On Push-Button Switch
 - 2 Pilot Light
 - 3 Power Off Push-Button Switch
- Use push-button switches to turn unit and pilot light On and Off. If input power is interrupted, the power On push button must be pressed to turn the unit On again.

Figure 4-12. Power Switch And Pilot Light

NOTE



The shielding gas preflow switch on the Relay Control board PC2 must be placed in the desired position when the Spot Time option is present (see Section 5-4).

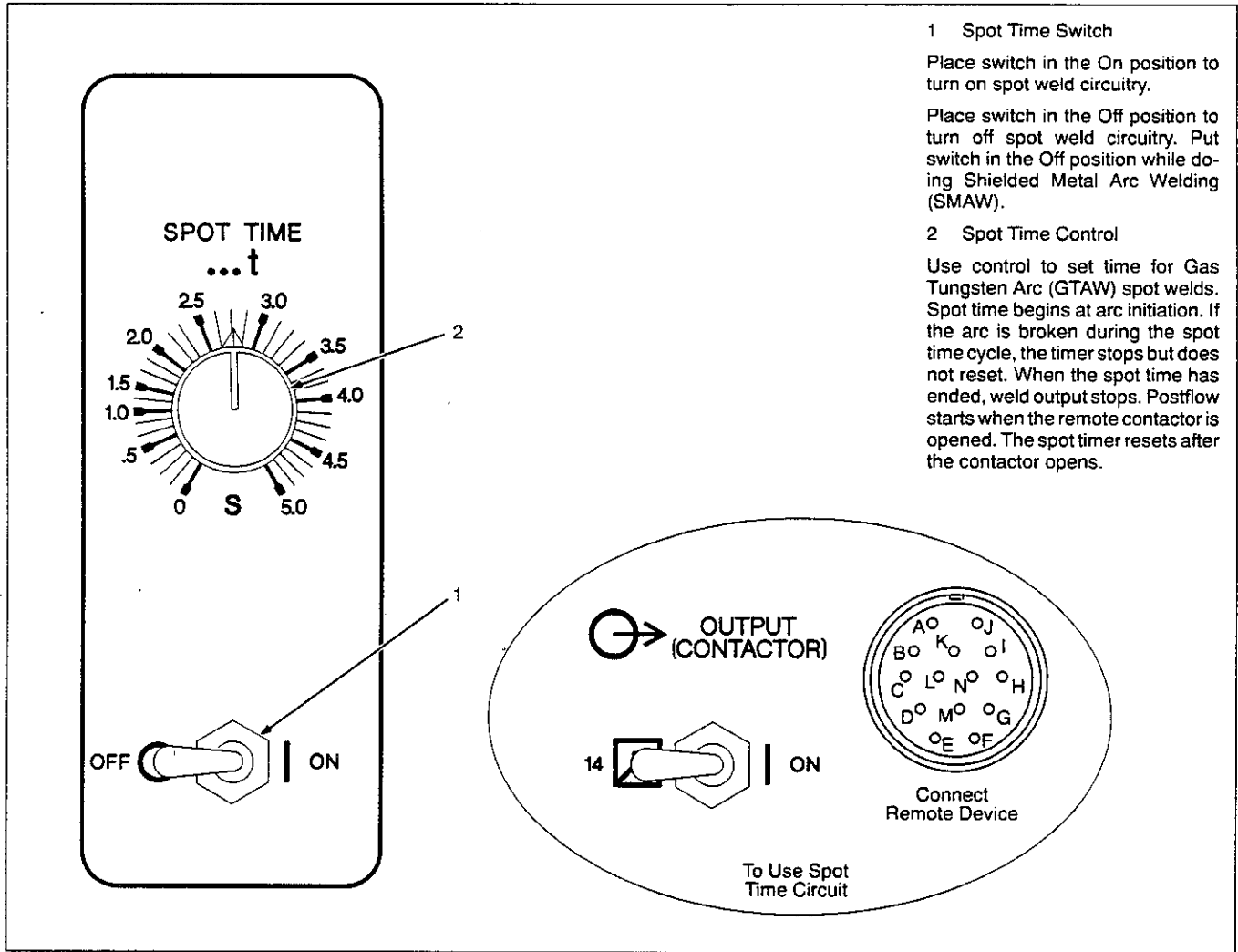

Figure 4-13. Spot Time Controls (Optional)

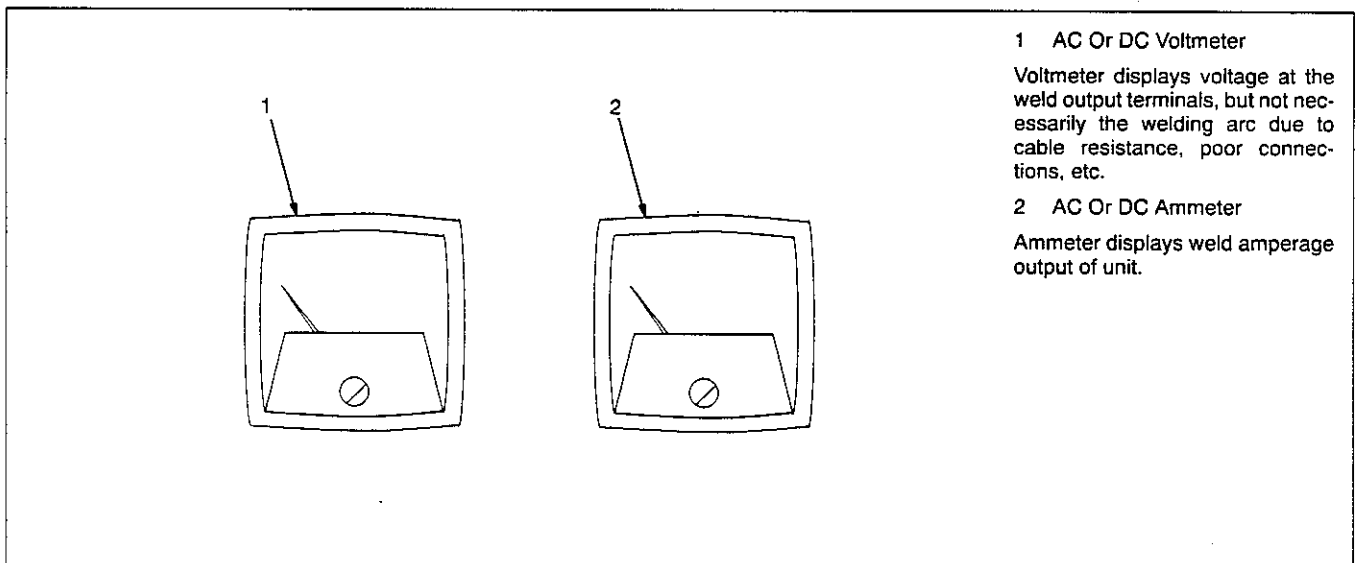

Figure 4-14. Ammeter And Voltmeter (Optional)

⚠ WARNING



BUILDUP OF SHIELDING GAS can harm health or kill.

- Shut off shielding gas supply when not in use.

warn1.1 9/91

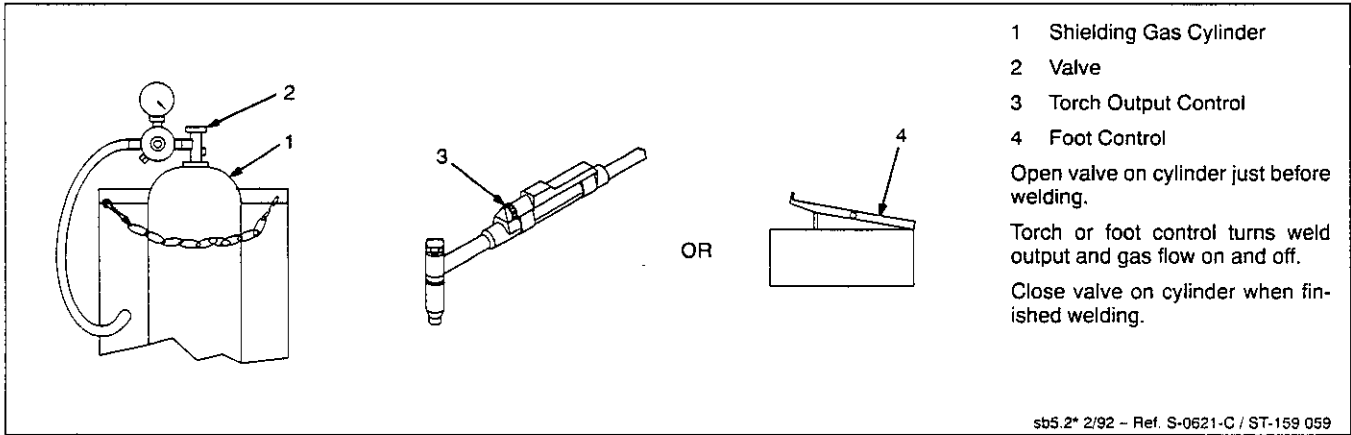

Figure 4-15. Shielding Gas

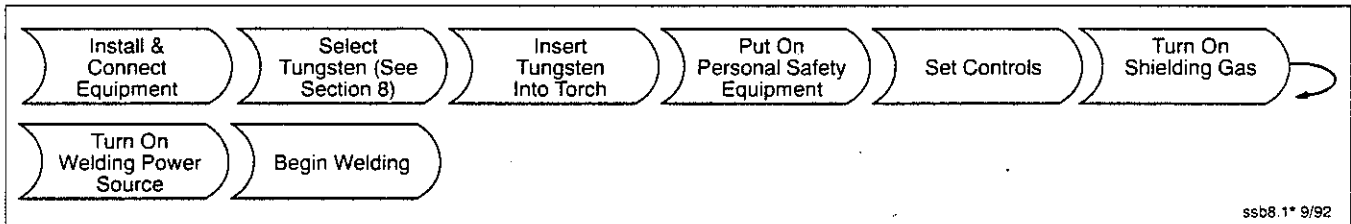

Figure 4-16. Sequence Of Gas Tungsten Arc Welding (GTAW) And Gas Tungsten Arc Spot Welding

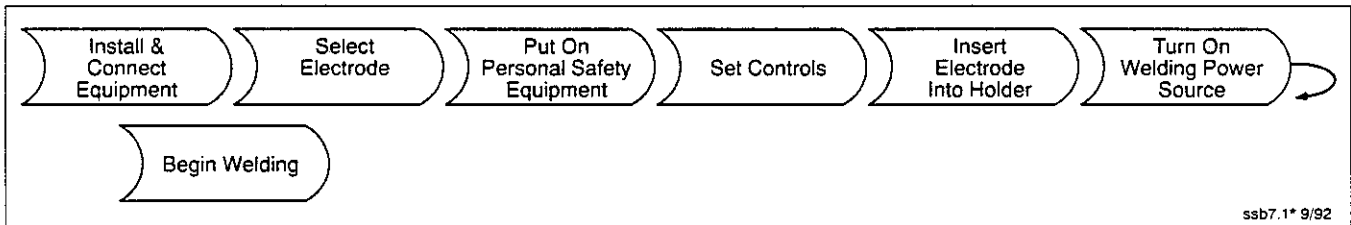







Figure 4-17. Sequence Of Shielded Metal Arc Welding (SMAW)

SECTION 5 – MAINTENANCE & TROUBLESHOOTING

 WARNING			
	ELECTRIC SHOCK can kill. <ul style="list-style-type: none"> Do not touch live electrical parts. Turn Off welding power source, and disconnect input power before inspecting, maintaining, or servicing. 		MOVING PARTS can cause injury. <ul style="list-style-type: none"> Keep away from moving parts.
	HOT PARTS can cause severe burns. <ul style="list-style-type: none"> Allow cooling period before maintaining or servicing. 		STATIC ELECTRICITY can damage parts on circuit boards. <ul style="list-style-type: none"> Put on grounded wrist strap BEFORE handling boards or parts. Use proper static-proof bags and boxes.
		Maintenance to be performed only by qualified persons. <small>swarn8.1* 10/91</small>	

5-1. Routine Maintenance

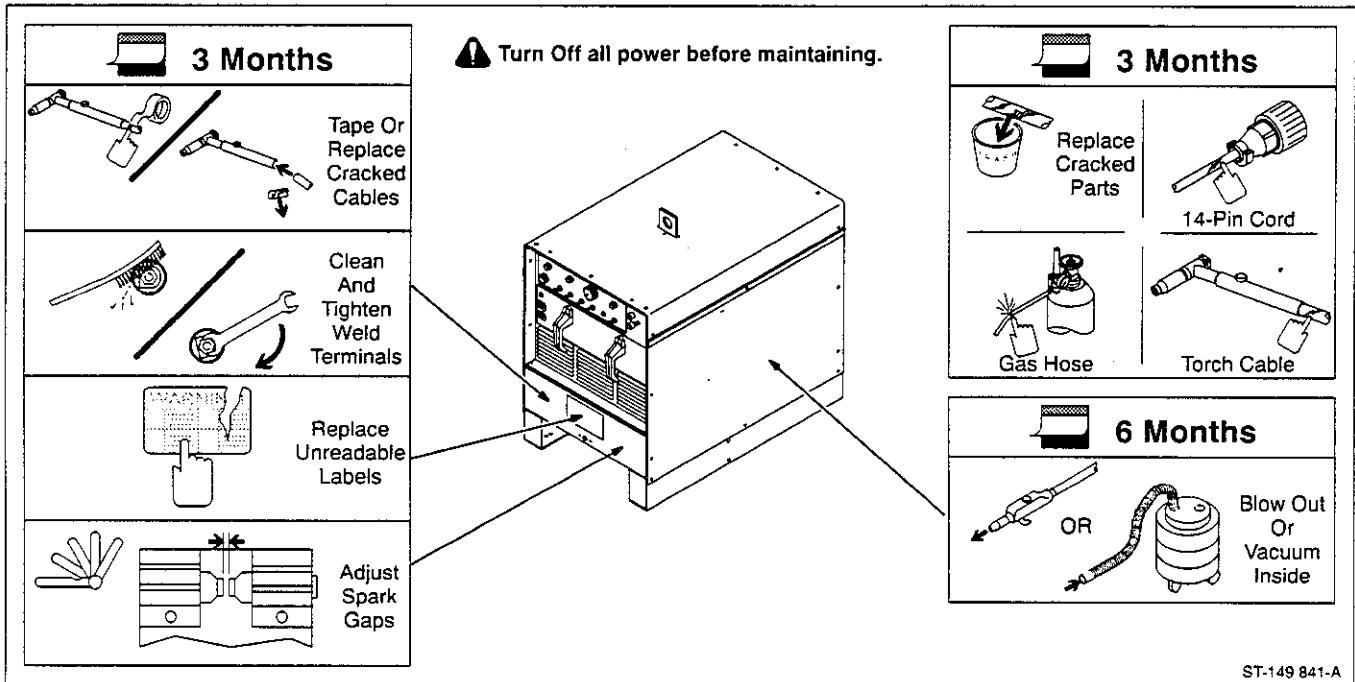

Figure 5-1. Maintenance Schedule

5-2. Overload Protection

 WARNING	  	READ SAFETY BLOCKS at start of Section 5 before proceeding.
--	---	--

A. Overheating

Thermostat TP1 protects the unit from damage due to overheating. If stabilizer Z gets too hot, TP1 opens and weld output stops. The fan keeps running to cool the transformer. Wait several minutes before trying to weld.

B. Fuses And Circuit Breakers

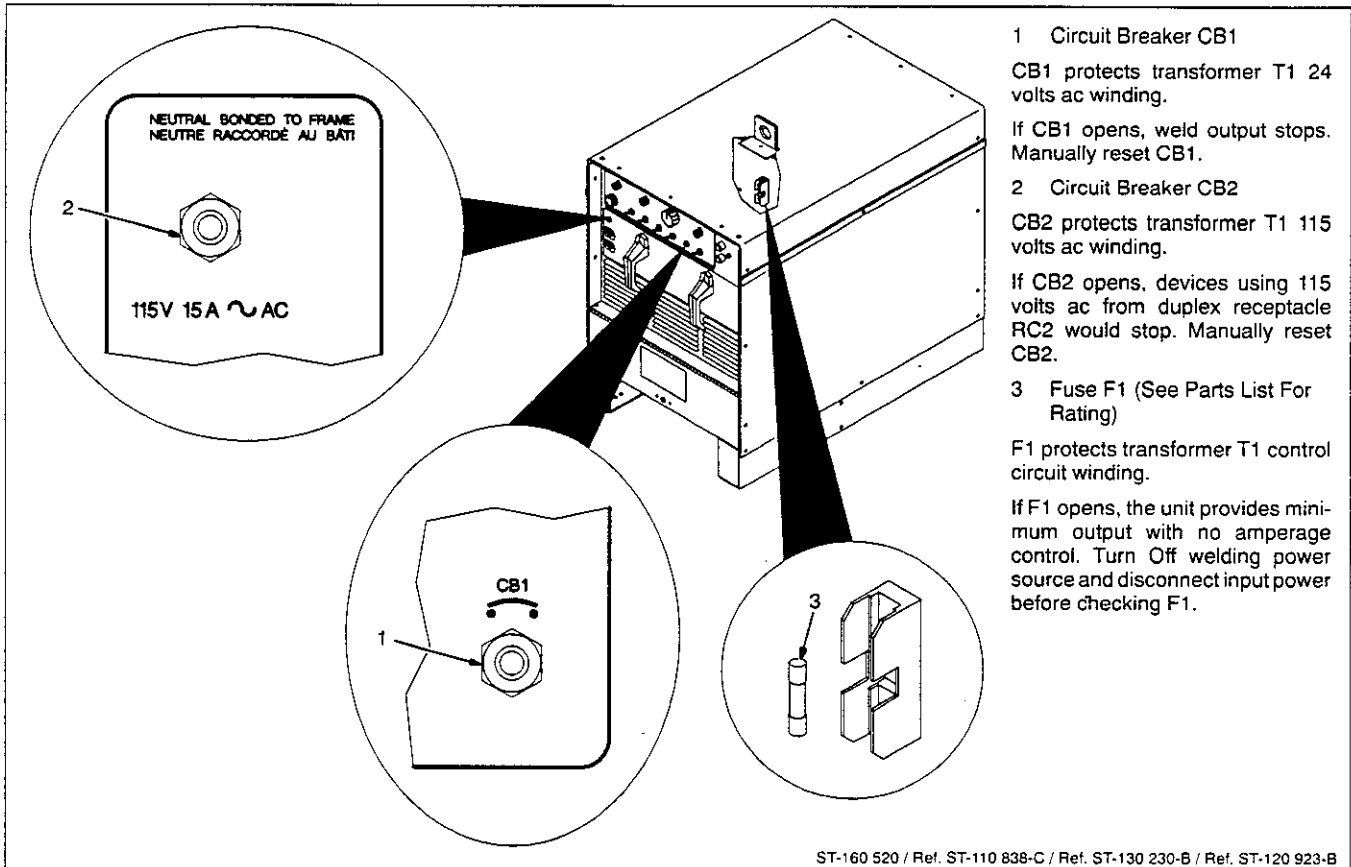

Figure 5-2. Overload Protection

5-3. Adjusting Spark Gaps

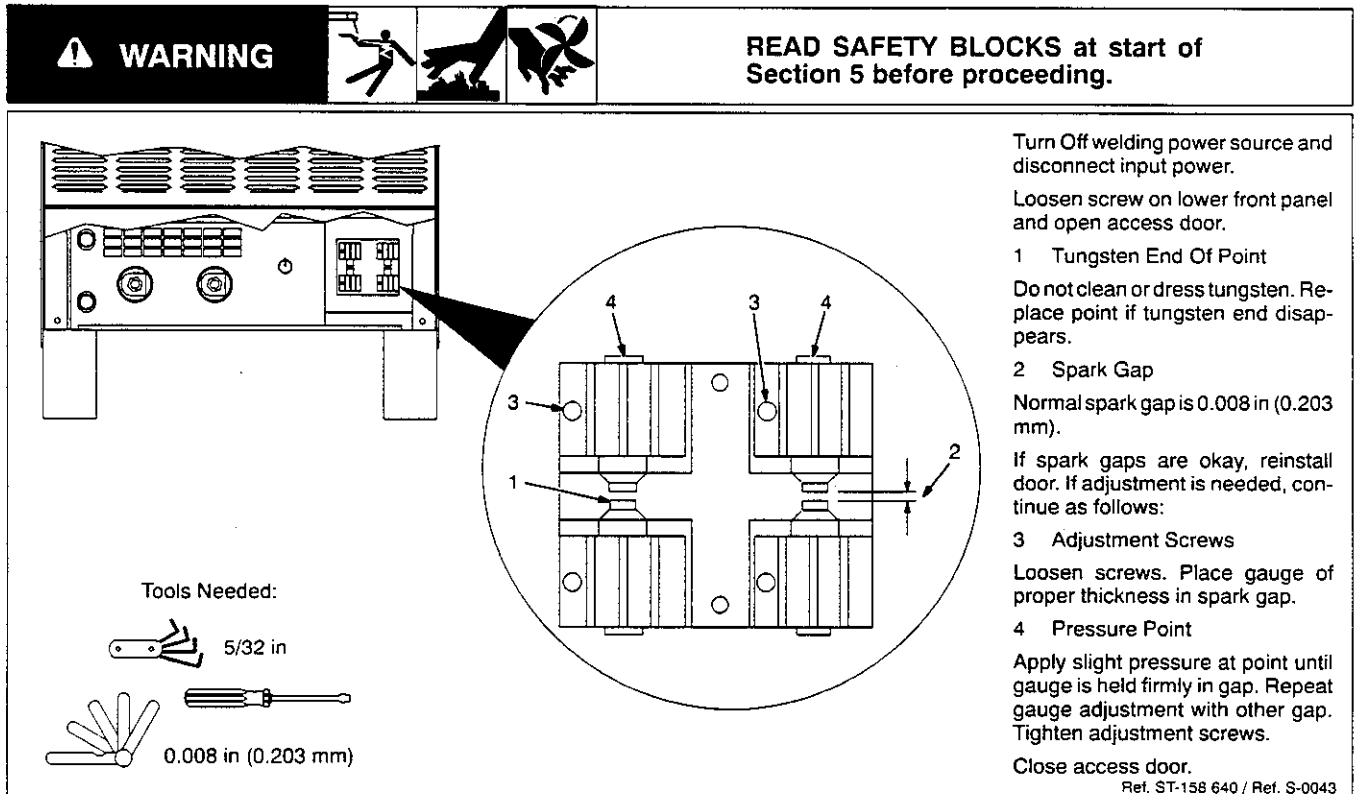

Figure 5-3. Adjusting Spark Gaps

5-4. Setting Preflow Function For Spot Weld Timer Option

WARNING



READ SAFETY BLOCKS at start of Section 5 before proceeding.

NOTE

To disable gas valve and prevent gas preflow for Shielded Metal Arc (SMAW) welding, place Output (Contactor) switch in On position, and disconnect Remote Contactor Control from Remote 14 receptacle.

Shielding gas preflow is available when the spot weld timer option is present. Preflow provides gas flow for about two seconds before an arc is started.

If the spot weld timer option is present, set shielding gas preflow according to the weld process in use.

Turn Off welding power source and disconnect input power. Open upper front access door.

- 1 Relay Control Board PC2
- 2 Preflow On/Off Switch S1

Switch positions are marked on PC2. Set switch in desired position.

Close and secure upper front access door.

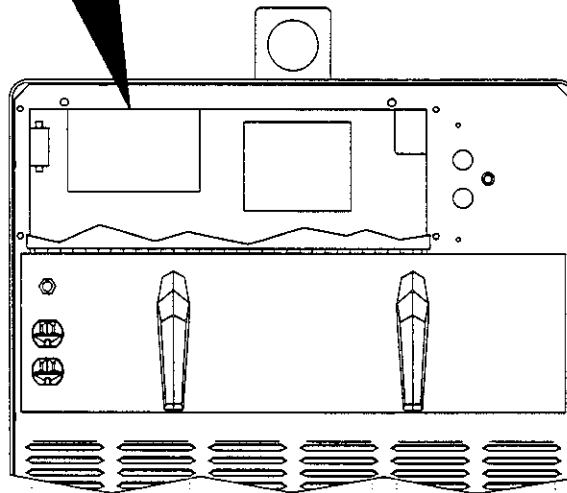
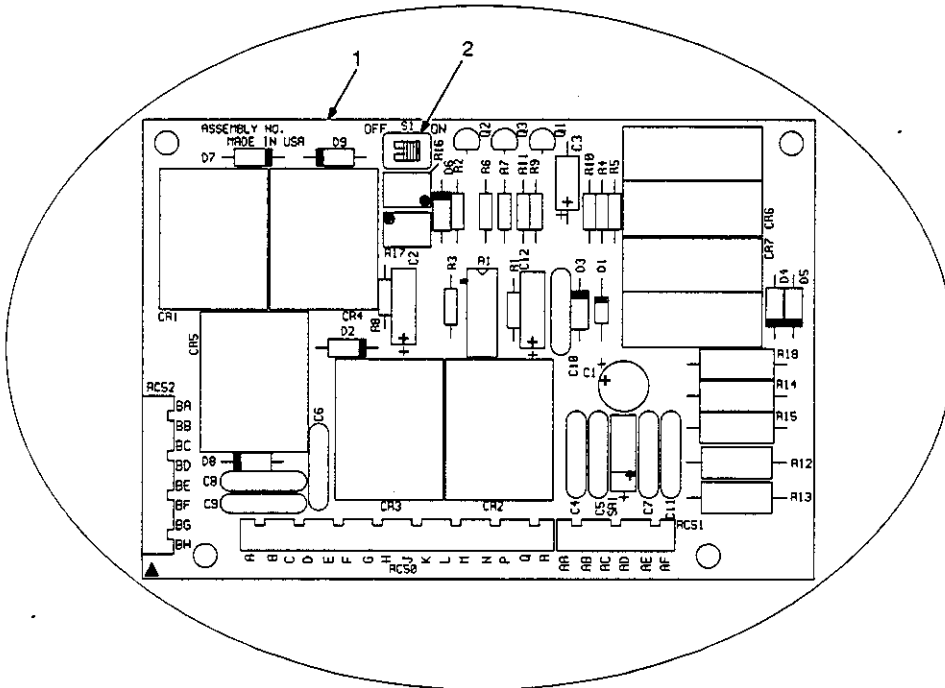

Tools Needed:

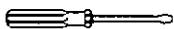

Ref. ST-158 641 / SA-157 845

Figure 5-4. Setting Preflow Function For Spot Weld Timer Option

5-5. Troubleshooting





 WARNING			
	ELECTRIC SHOCK can kill. <ul style="list-style-type: none"> Do not touch live electrical parts. Turn Off welding power source, and disconnect input power before inspecting, maintaining, or servicing. 		MOVING PARTS can cause injury. <ul style="list-style-type: none"> Keep away from moving parts.
	HOT PARTS can cause severe burns. <ul style="list-style-type: none"> Allow cooling period before maintaining or servicing. 		STATIC ELECTRICITY can damage parts on circuit boards. <ul style="list-style-type: none"> Put on grounded wrist strap BEFORE handling boards or parts. Use proper static-proof bags and boxes.
			Troubleshooting to be performed only by qualified persons. <div style="text-align: right; font-size: small;">swarn9.1* 4/92</div>

Table 5-1. Welding Trouble

Trouble	Remedy	Section
No weld output; unit completely inoperative; pilot light PL1 not on.	Place line disconnect switch in the On position.	3-9B
	Check and replace line fuse(s) or reset circuit breaker CB1.	3-9B
	Check for proper input connections.	3-9B
	Check for proper jumper link positions.	3-9A
	Reset circuit breaker CB1.	5-2B
	Check contactor W.	--
No weld output; fan on; pilot light PL1 on.	If remote control is not used, place Output (Contactor) switch in On position. If remote control is used, place switch in Remote 14 position, and be sure remote control is connected to Remote 14 receptacle.	3-6, Figure 4-7
	Be sure Range Selector switch is not between positions.	Figure 4-5
	Check remote control.	--
	Unit overheated. Allow unit to cool with fan On.	5-2A
	Have Factory Authorized Service Station check Relay Control board PC2.	--
Low weld output; no control of weld output.	If Amperage Control switch is in Remote position, connect remote amperage control to Remote 14 receptacle RC1.	3-6, Figure 4-8
	Check fuse F1 and replace if open.	5-2B
	Have Factory Authorized Service Station check Mag Amp Control board PC1.	--
Erratic weld output.	Clean and tighten all weld connections.	3-3, 3-5
	Be sure electrode is dry and proper type for SMAW.	--
	Be sure tungsten is correct size for GTAW.	8-1
	Use proper size and type weld cable.	3-3

Trouble	Remedy	Section
Fan motor FM does not run.	Check Power switch S1. Check fan motor FM.	-- --
No 115 volts ac output at duplex receptacle RC2; weld output available.	Reset circuit breaker CB2.	5-2B
Tungsten electrode oxidizing and not remaining bright after conclusion of weld.	Shield weld zone from drafts. Increase postflow time. Check and tighten all gas fittings. Properly prepare tungsten. Replace torch parts if water has leaked into torch.	-- Figure 4-9 3-8 8-2 --
Lack of high frequency; difficulty in establishing an arc.	Select proper size tungsten. Place High Frequency switch in correct position. Check High Frequency Intensity control R7 setting. Be sure that electrode holder cable is not close to any grounded metal. Check cables and torch for cracked insulation or bad connections. Repair or replace necessary parts. Check spark gaps and adjust if necessary.	8-1 Figure 4-11 Figure 4-11 -- -- 5-3
No high frequency.	Check position of High Frequency switch S4. If High Frequency switch S4 is in Start position, check control relay CR1. Have Factory Authorized Service Station check Relay Control board PC2.	Figure 4-11 -- --
Wandering arc -- poor control of direction of arc.	Reduce gas flow rate. Select proper size tungsten. Properly prepare tungsten.	3-8 8-1 8-2

SECTION 6 - ELECTRICAL DIAGRAMS

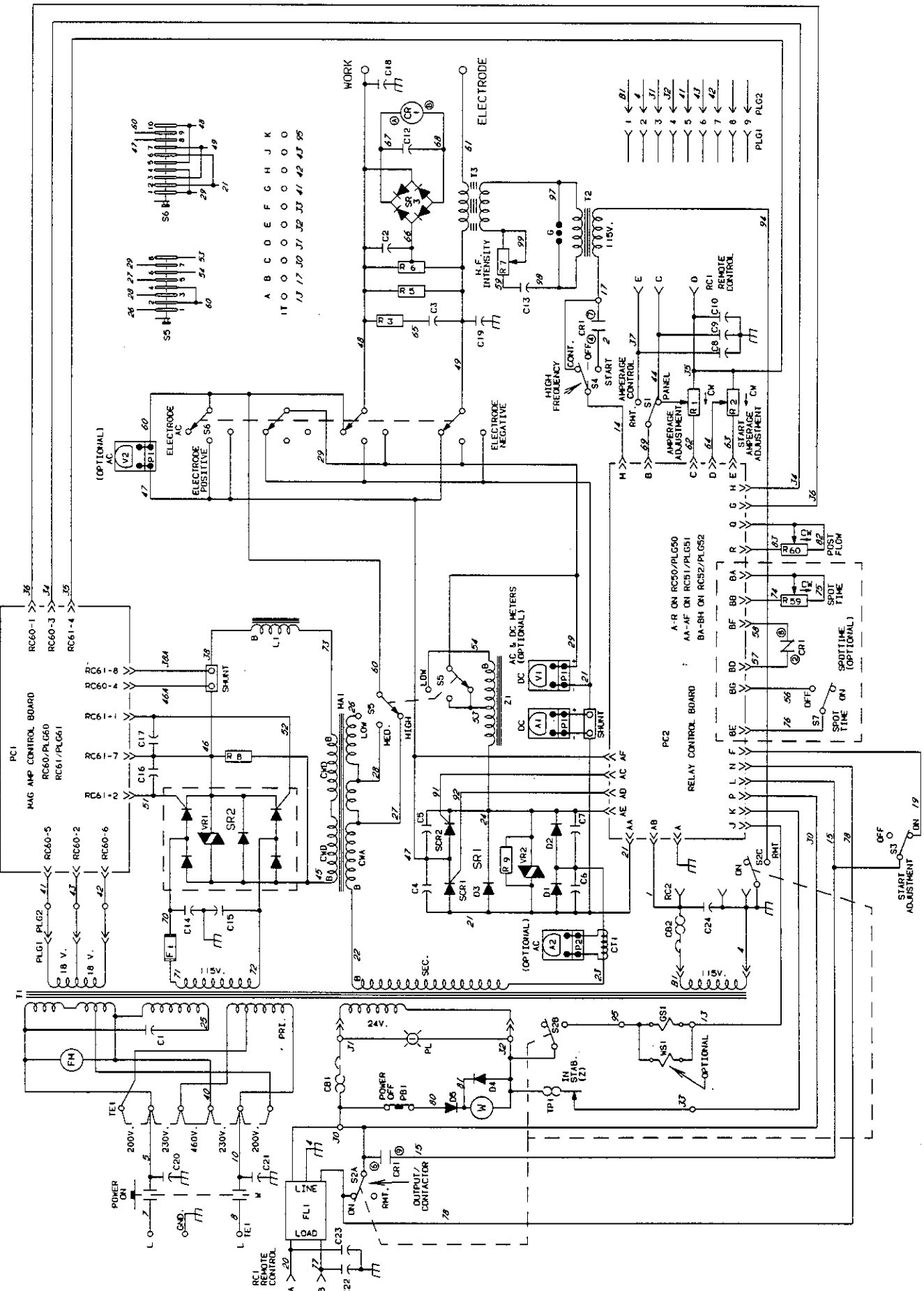

SC-136 997

Figure 6-1. Circuit Diagram For Welding Power Source

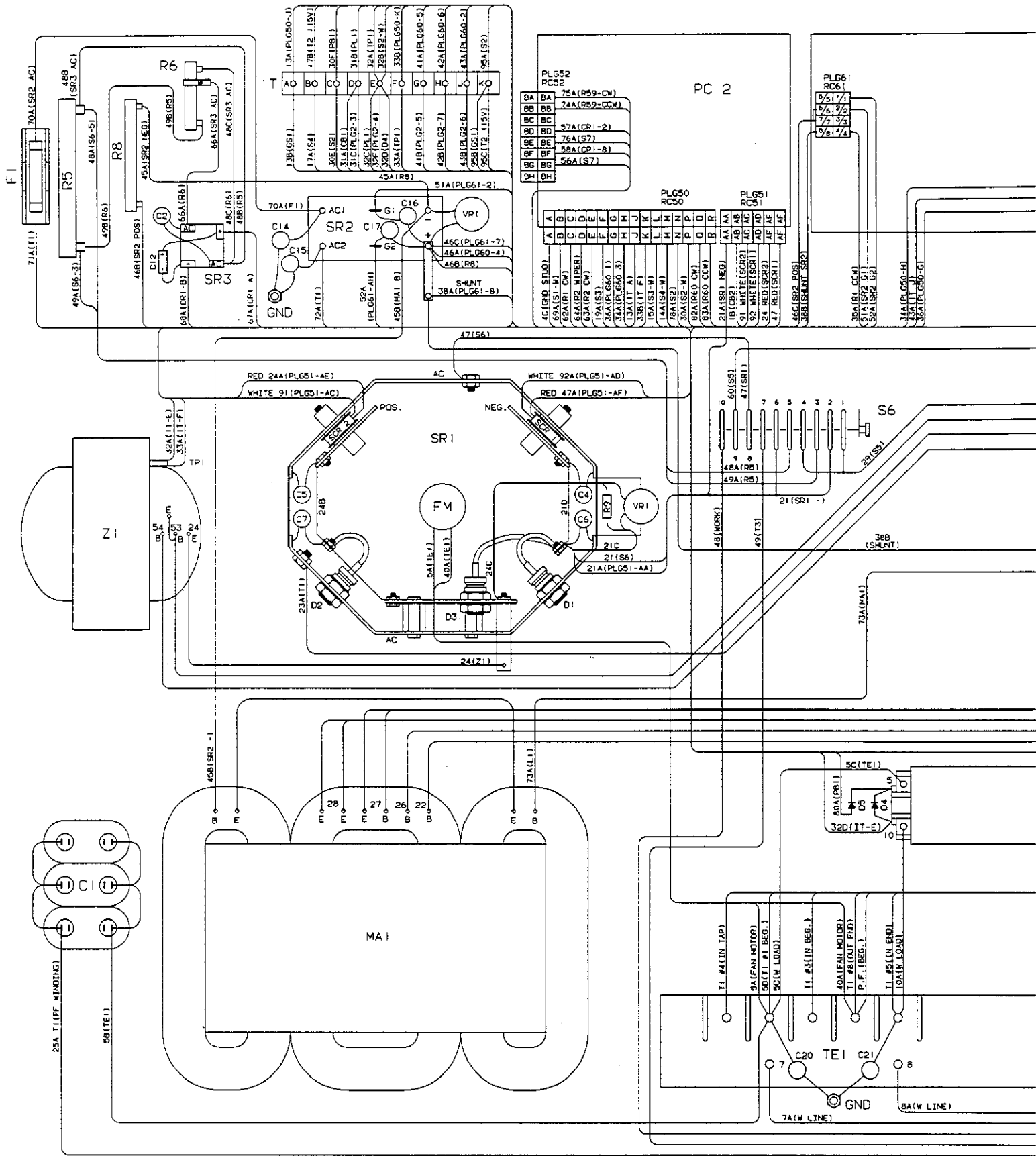
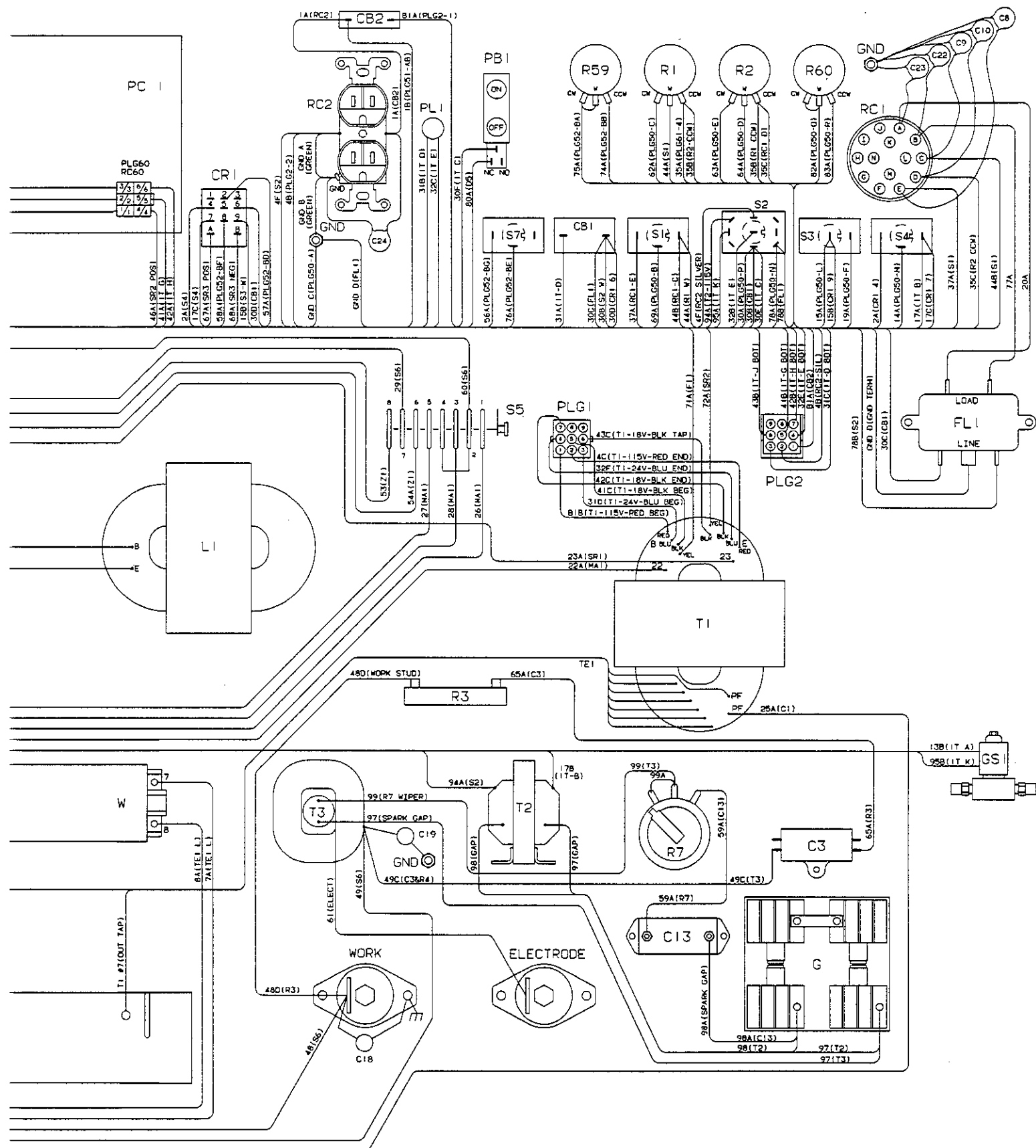

Figure 6-2. Wiring Diagram For Welding Power Source



SECTION 7 – HIGH FREQUENCY

mod6.1 11/92

⚠ WARNING

HIGH-FREQUENCY RADIATION can interfere with radionavigation, safety services, computers, and communications equipment.

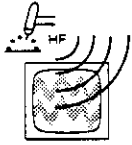

- Have only qualified person familiar with electronic equipment perform this installation.
- The user is responsible for having a qualified electrician promptly correct any interference problem resulting from the installation.
- If notified by the FCC about interference, stop using the equipment at once.
- Have the installation regularly checked and maintained.
- Keep high-frequency source doors and panels tightly shut, keep spark gaps at correct setting, and use grounding and shielding as shown in Figure 7-3 to minimize the possibility of interference.

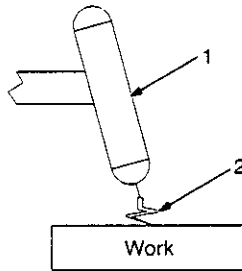

Gas Tungsten Arc Welding (GTAW)

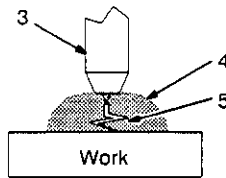

Submerged Arc Welding (SAW)

- 1 Gas Tungsten Arc Torch
- 2 High-Frequency Voltage
Used to help arc jump air gap between torch and workpiece and/or stabilize the arc.
- 3 Submerged Arc Welding Gun
- 4 Flux
- 5 High-Frequency Voltage
Used to help arc reach workpiece through flux granules.

S-0693

Figure 7-1. Welding Processes Requiring High-Frequency

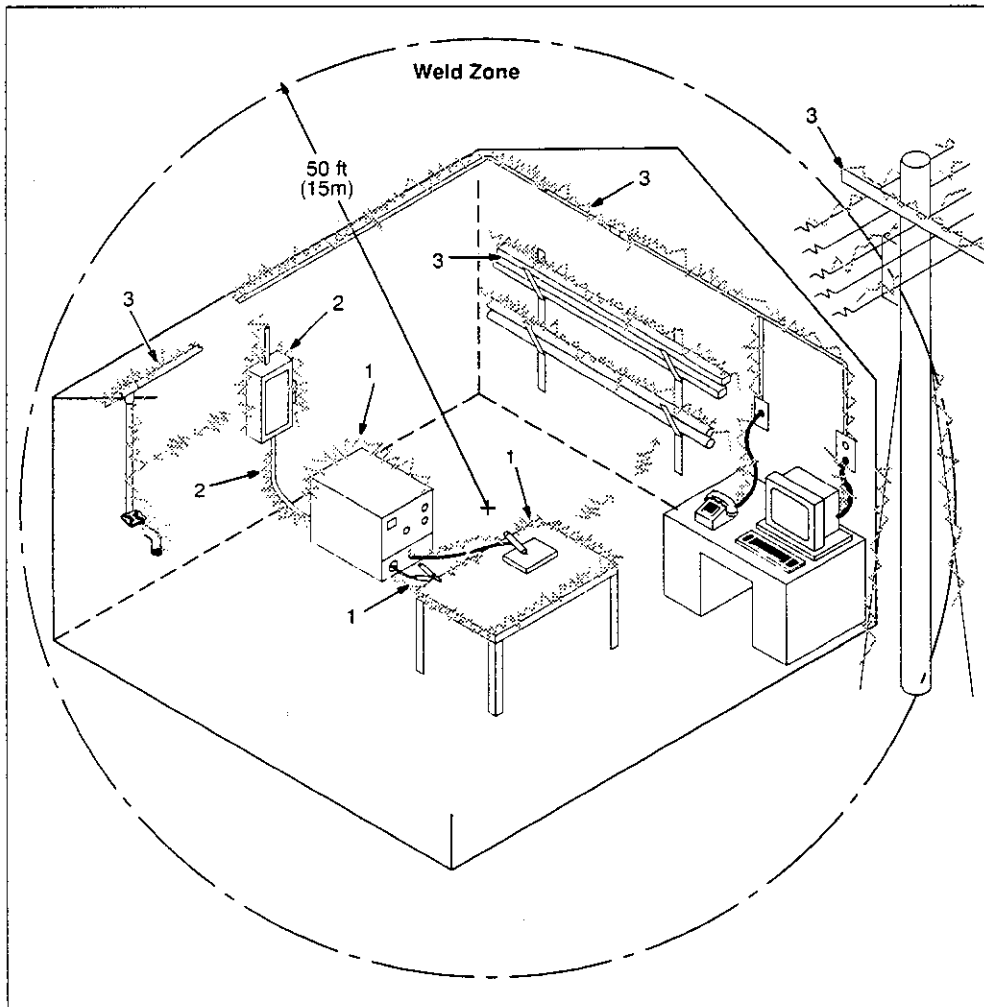

- 1 Sources Of Direct High-Frequency Radiation
High-frequency source (welder with built-in HF or separate HF unit), weld cables, torch, work clamp, workpiece, and work table.
- 2 Sources of Conduction Of High-Frequency
Input power cable, line disconnect switch, and input supply wiring.
- 3 Sources Of Reradiation Of High-Frequency
Ungrounded metal objects, lighting, wiring, water pipe and fixtures, external phone and power lines.

S-0694

Figure 7-2. Sources Of High-Frequency Radiation From Incorrect Installation Of High-Frequency Source

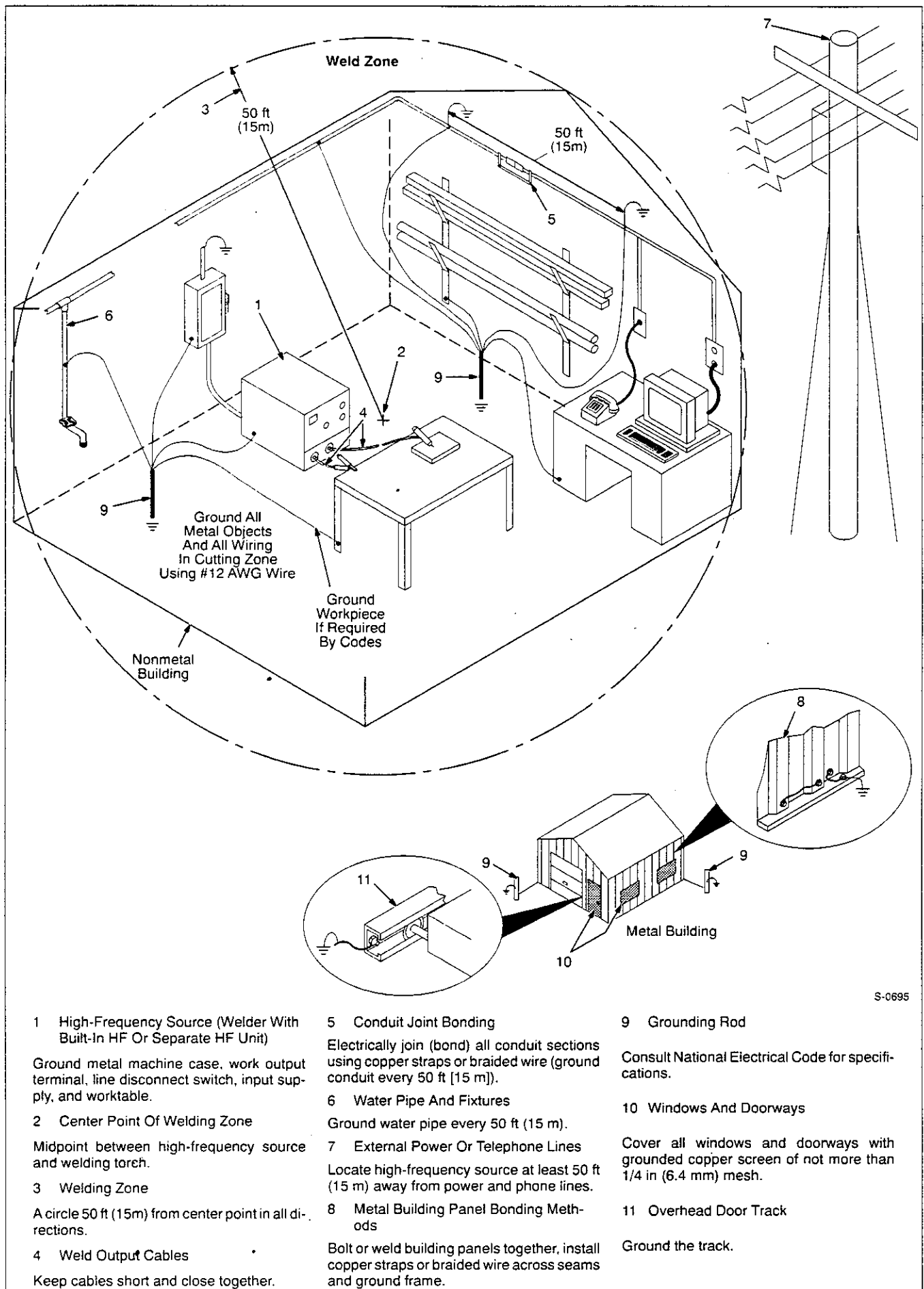

S-0695

1 High-Frequency Source (Welder With Built-In HF Or Separate HF Unit)

Ground metal machine case, work output terminal, line disconnect switch, input supply, and worktable.

2 Center Point Of Welding Zone

Midpoint between high-frequency source and welding torch.

3 Welding Zone

A circle 50 ft (15m) from center point in all directions.

4 Weld Output Cables

Keep cables short and close together.

5 Conduit Joint Bonding

Electrically join (bond) all conduit sections using copper straps or braided wire (ground conduit every 50 ft [15 m]).

6 Water Pipe And Fixtures

Ground water pipe every 50 ft (15 m).

7 External Power Or Telephone Lines

Locate high-frequency source at least 50 ft (15 m) away from power and phone lines.

8 Metal Building Panel Bonding Methods

Bolt or weld building panels together, install copper straps or braided wire across seams and ground frame.

9 Grounding Rod

Consult National Electrical Code for specifications.

10 Windows And Doorways

Cover all windows and doorways with grounded copper screen of not more than 1/4 in (6.4 mm) mesh.

11 Overhead Door Track

Ground the track.

Figure 7-3. Correct Installation Of High-Frequency Source

SECTION 8 – TUNGSTEN ELECTRODE

mod2.1 9/92

NOTE



For additional information, see your distributor for a handbook on the Gas Tungsten Arc Welding (GTAW) process.

8-1. Selecting Tungsten Electrode

Table 8-1. Tungsten Size

Electrode Diameter	Amperage Range - Gas Type♦ - Polarity			
	DC – Argon – Electrode Negative/Straight Polarity	DC – Argon – Electrode Positive/Reverse Polarity	AC – Argon – Using High Frequency	AC – Argon – Balanced Wave Using High Freq.
Pure Tungsten (Green Band)				
.010"	Up to 15	*	Up to 15	Up to 10
.020"	5-20	*	5-20	10-20
.040"	15-80	*	10-60	20-30
1/16"	70-150	10-20	50-100	30-80
3/32"	125-225	15-30	100-160	60-130
1/8"	225-360	25-40	150-210	100-180
5/32"	360-450	40-55	200-275	160-240
3/16"	450-720	55-80	250-350	190-300
1/4"	720-950	80-125	325-450	250-400
2% Thorium Alloyed Tungsten (Red Band)				
.010"	Up to 25	*	Up to 20	Up to 15
.020"	15-40	*	15-35	5-20
.040"	25-85	*	20-80	20-60
1/16"	50-160	10-20	50-150	60-120
3/32"	135-235	15-30	130-250	100-180
1/8"	250-400	25-40	225-360	160-250
5/32"	400-500	40-55	300-450	200-320
3/16"	500-750	55-80	400-500	290-390
1/4"	750-1000	80-125	600-800	340-525
Zirconium Alloyed Tungsten (Brown Band)				
.010"	*	*	Up to 20	Up to 15
.020"	*	*	15-35	5-20
.040"	*	*	20-80	20-60
1/16"	*	*	50-150	60-120
3/32"	*	*	130-250	100-180
1/8"	*	*	225-360	160-250
5/32"	*	*	300-450	200-320
3/16"	*	*	400-550	290-390
1/4"	*	*	600-800	340-525

♦Typical argon shielding gas flow rates are 15 to 35 cfh (cubic feet per hour).

*Not Recommended.

The figures listed are intended as a guide and are a composite of recommendations from American Welding Society (AWS) and electrode manufacturers.

S-0009

8-2. Preparing Tungsten

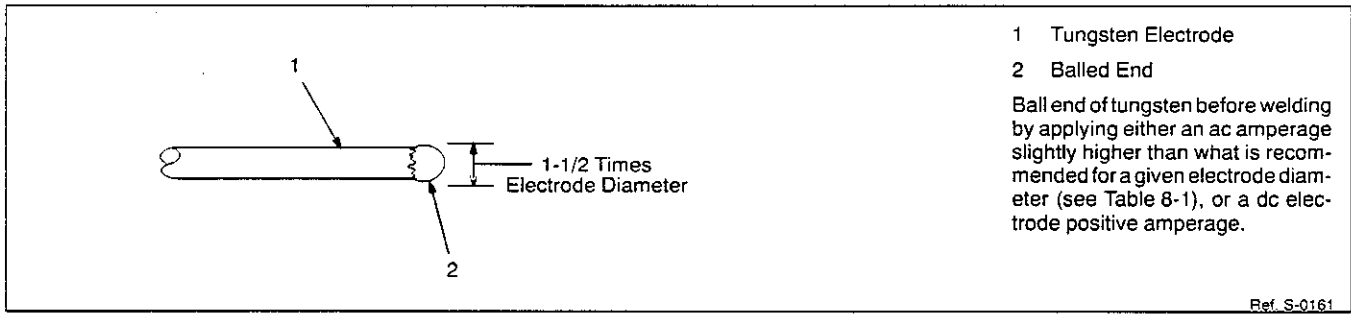

Figure 8-1. Preparing Tungsten For AC Or DC Electrode Positive (DCEP) Welding

CAUTION

FLYING SPARKS AND HOT METAL can cause injury and start fires.

- Shape tungsten electrode only on grinder with proper guards in a safe location wearing proper face, hand, and body protection.
- Keep flammables away.

warn2.1 9/91

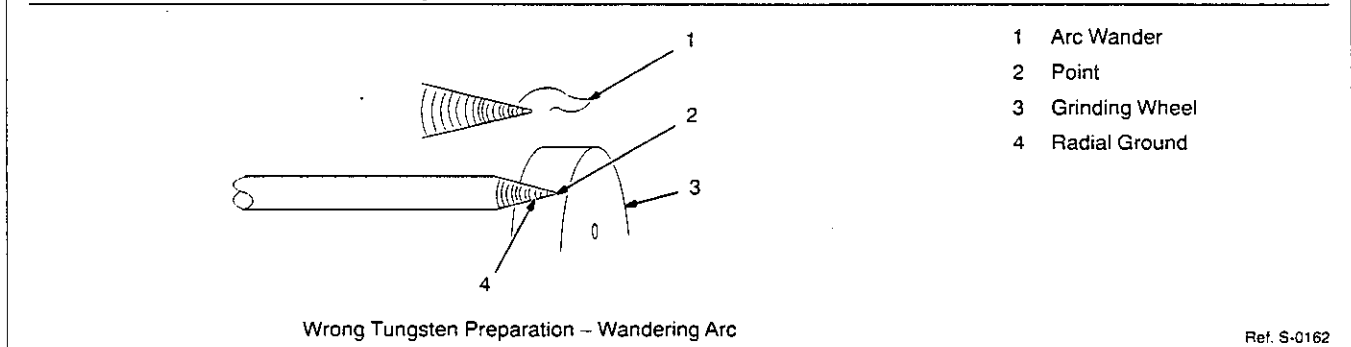
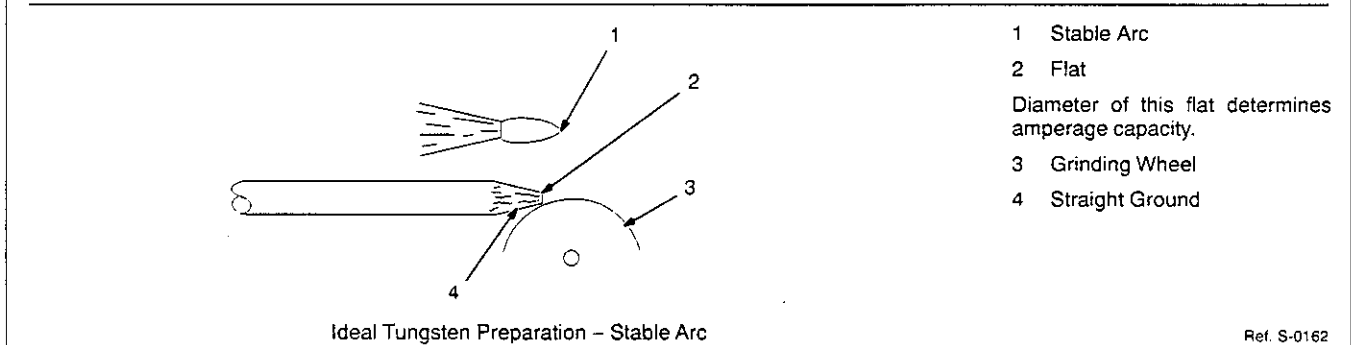
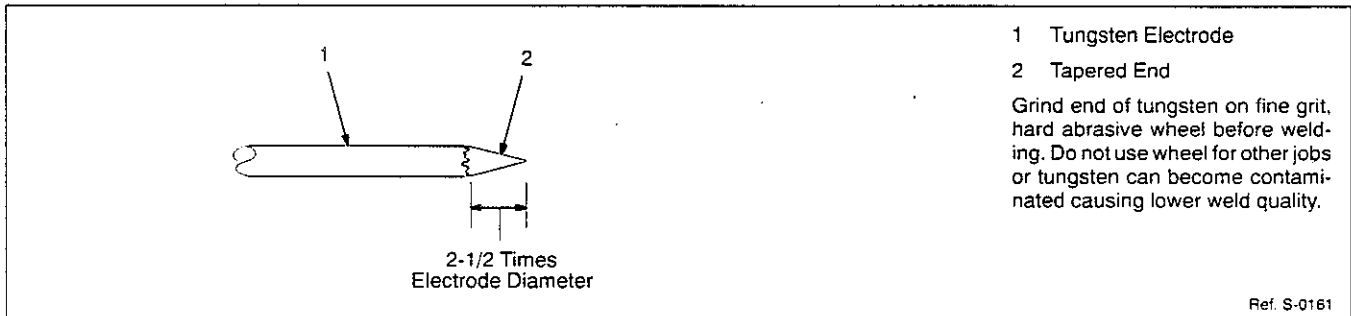

Figure 8-2. Preparing Tungsten For DC Electrode Negative (DCEN) Welding

SECTION 9 – PARTS LIST

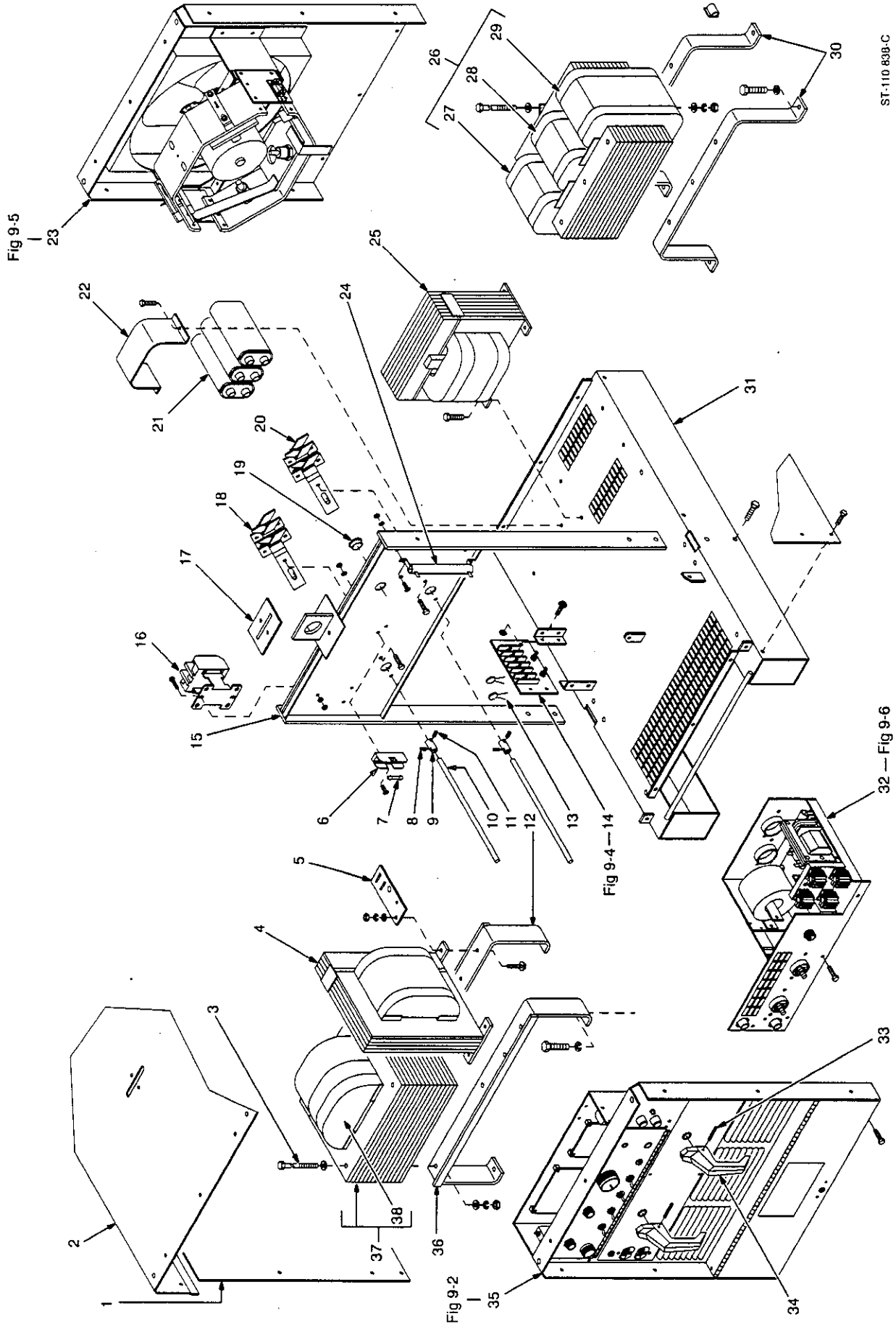

Figure 9-1. Main Assembly

Replace Coils At Factory Or Authorized Service Station

Item No.	Dia. Mkgs.	Part No.	Description	Quantity
Figure 9-1. Main Assembly				
1		+098 294	PANEL, side	2
		109 035	LABEL, warning electric shock can kill etc	1
2		121 464	COVER, top	1
3		110 881	SCREW, .312-18 x 7.000 hex hd pln stl	6
4	L1	098 299	CHOKE	1
5		108 100	RETAINER, bus bar	1
6		012 604	HOLDER, fuse crtg 30A 250V	1
7	F1	*012 610	FUSE, crtg 25A 250V	1
		121 462	SHAFT, extension switch (consisting of)	2
8		106 398	PIN, spring CS .156 x .625	1
9		094 609	COUPLING, shaft extension	1
10		121 463	SHAFT, extension	1
11		106 398	PIN, spring CS .156 x .625	2
12		107 881	BRACKET, support transformer rear	1
13	C20,21	091 141	CAPACITOR	2
14	TE1	034 587	TERMINAL ASSEMBLY, pri (Fig 9-4)	1
15		098 301	FRAME, upright	1
		134 771	PLUG, protective .640sq	4
	D4,5	082 456	DIODE ASSEMBLY	1
16	W	137 902	CONTACTOR	1
17		026 627	GASKET, lifting eye	1
18	S5	134 630	SWITCH, range	1
19		030 170	BUSHING, snap-in nyl .750 ID x 1.000mtg hole	1
20	S6	134 629	SWITCH, polarity/range	1
21	C1	107 211	CAPACITOR, polyp met film 35uf 480VAC	3
22		025 142	BRACKET, mtg capacitor	1
23		Fig 9-5	PANEL, rear w/components	1
24	R5	030 965	RESISTOR, WW fxd 100W 100 ohm	1
25	Z	098 302	STABILIZER, (consisting of)	1
	TP1	026 181	THERMOSTAT, NC	1
26	MA1	109 633	AMPLIFIER, (consisting of)	1
27		098 194	COIL, contact LH	1
28		098 192	COIL, contact ac	1
29		098 193	COIL, contact RH	1
30		098 280	BRACKET, support amplifier	2
31		121 632	BASE	1
32		128 702	HF CONTROL, (Fig 9-6)	1
33		010 647	PIN, spring CS .156 x 1.250	2
34		098 279	HANDLE, switch range	2
35		Fig 9-2	PANEL, front w/cmpnts	1
36		107 880	BRACKET, support transformer front	1
37	T1	140 548	TRANSFORMER, power main 200/230/360 (consisting of)	1
38		140 605	COIL, pri/sec	1
37	T1	140 545	TRANSFORMER, power main 230/460/575 (consisting of)	1
38		140 606	COIL, pri/sec	1
		140 505	KIT, label	1

+When ordering a component originally displaying a precautionary label, the label should also be ordered.

*Recommended Spare Parts.

BE SURE TO PROVIDE MODEL AND SERIAL NUMBER WHEN ORDERING REPLACEMENT PARTS.

Item No.	Dia. Mkgs.	Part No.	Description	Quantity
----------	------------	----------	-------------	----------

Figure 9-2. Panel, Front w/Components (Fig 9-1 Item 35)

1	RC1	143 976	CONNECTOR w/SOCKETS, (consisting of)	1
		079 534	CONNECTOR, circ skt push-in 14-18ga Amp 66358-6	14
		134 734	CONNECTOR, circ 14 pin plug Amp 213571-2	
		134 731	CONNECTOR, circ pin push-in 14-18ga Amp 213603-1	
		079 739	CONNECTOR, circ clamp str rlf sz 17-20 Amp 206322-2	
	C8	144 299	LEAD ASSEMBLY, elect	1
	C9	144 303	LEAD ASSEMBLY, elect	1
	C10	144 300	LEAD ASSEMBLY, elect	1
	C22	144 302	LEAD ASSEMBLY, elect	1
	C23	144 301	LEAD ASSEMBLY, elect	1
2		010 855	RETAINER, screw No. 2	2
3	R60	030 686	POTENTIOMETER, C sltd sft 1/T 2W 2 meg ohm	1
4	R1,2	035 897	POTENTIOMETER, C sltd sft 1/T 2W 1K ohm	2

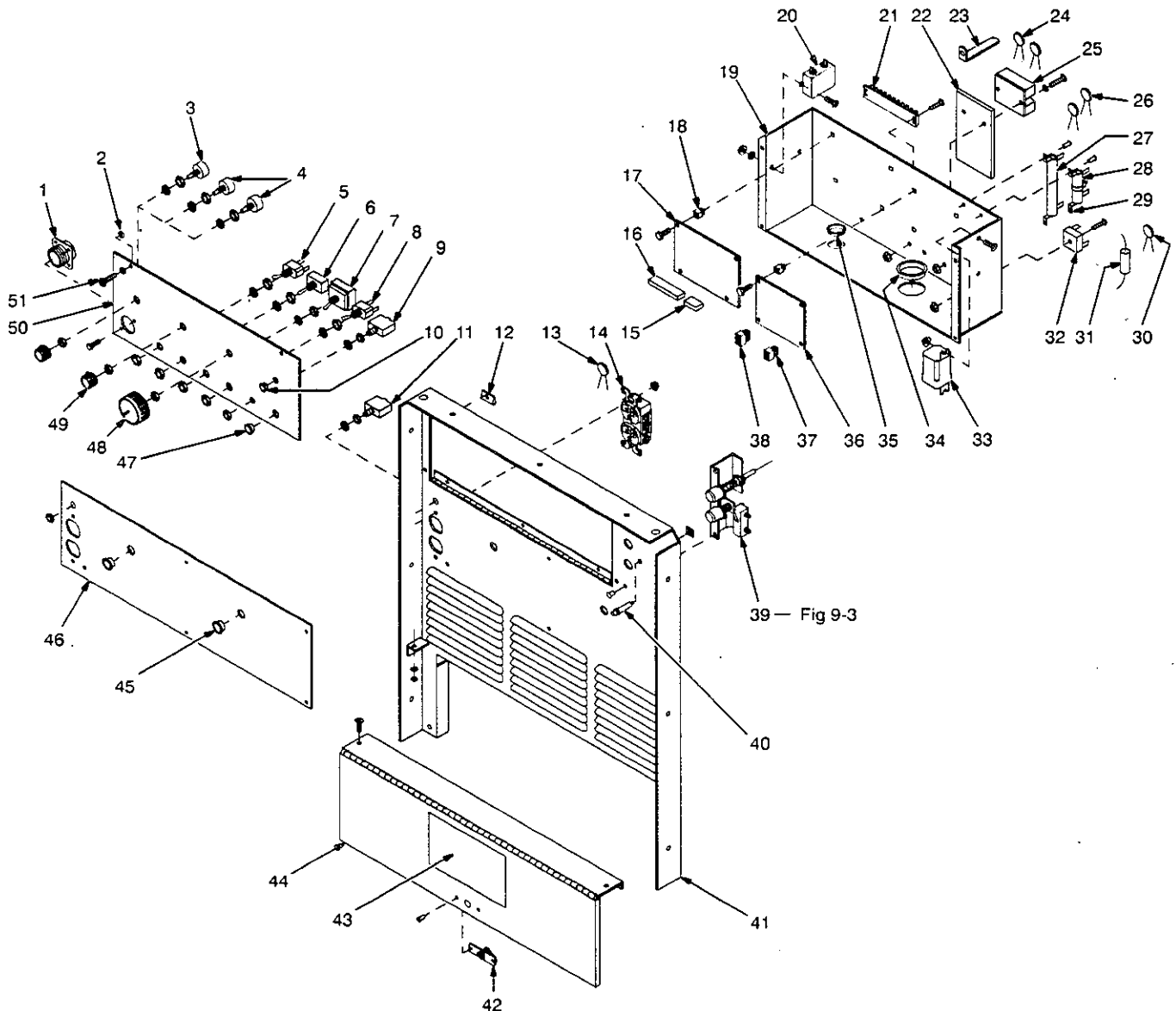

ST-110 839-E

Figure 9-2. Panel, Front w/Components

Item No.	Dia. Mkgs.	Part No.	Description	Quantity
----------	------------	----------	-------------	----------

Figure 9-2. Panel, Front w/Components (Fig 9-1 Item 35) (Continued)

5	S4	011 610	SWITCH, tgl SPDT 10A 125VAC	1
6	S3	089 085	SWITCH, tgl SPST 20A 125VAC	1
7	S2	011 622	SWITCH, tgl 3PDT 15A 125VAC	1
8	S1	011 609	SWITCH, tgl SPDT 15A 125VAC	1
9	CB1	083 432	CIRCUIT BREAKER, man reset 1P 10A 250V	1
10		057 359	BLANK, snap-in nyl .375mtg hole	1
11	CB2	093 995	CIRCUIT BREAKER, man reset 1P 15A 250VAC	1
12		010 357	NUT, speed No. 2 clip on	2
13	C24	135 664	CAPACITOR	1
14	RC2	604 176	RECEPTACLE, str dx grd 2P3W 15A 125V	1
		073 690	PLUG, str grd armd 2P3W 15A 125V Arrow Hart 5965V	
15	PLG51	084 198	CONNECTOR, rect 6skt plug Amp 87159-6 (included w/SR1)	1
		081 378	CONNECTOR, rect skt 22-18ga Amp 102100-2	6
16	PLG50	141 642	CONNECTOR PLUG & SOCKETS, (consisting of)	1
		113 746	CONNECTOR, rect skt 24-18ga Molex 39-00-0038	16
17	PC2	157 848	CIRCUIT CARD, relay	1
18		083 147	GROMMET, scr 8/10 panel hole .312sq .500 high	8
19		098 991	ENCLOSURE, circuit card	1
20	FL1	084 171	FILTER, line pwr 115/250V	1
21	1T	098 828	BLOCK, term 10A 10P	1
22		092 344	HEAT SINK	1
23	Shunt	044 968	SHUNT, resistor	1
24	C16,17	109 689	CAPACITOR	1
25	SR2,VR1	080 907	DIODE/SCR, integ bridge	1
26	C14,15	111 465	CAPACITOR	1
27	R8	030 908	RESISTOR, WW fxd 50W 150 ohm	1
28	R6	030 601	RESISTOR, WW adj 25W 1K ohm	1
29		605 741	CLIP, mtg resistor .312 ID core	4
30	C2	109 692	CAPACITOR	1
31	C12	031 630	CAPACITOR, elctlt 22uf 50VDC	1
32	SR3	035 704	RECTIFIER, integ 40A 800V	1
		059 712	CLIP, component .437dia mtg adh back	1
33	CR1	059 267	RELAY, encl 12VDC DPDT	1
34		010 494	BUSHING, snap-in nyl 1.375 ID x 1.750mtg hole	1
35		057 357	BUSHING, snap-in nyl .937 ID x 1.125mtg hole	1
36	PC1	133 771	CIRCUIT CARD, control mag amp	1
37	PLG60	115 093	CONNECTOR PLUG & SOCKETS, (consisting of)	1
		113 746	CONNECTOR, rect skt 24-18ga Molex 39-00-0038	6
38	PLG61	115 092	CONNECTOR PLUG & SOCKETS, (consisting of)	1
		113 746	CONNECTOR, rect skt 24-18ga Molex 39-00-0038	8
39	PB1	046 746	SWITCH, PB (Fig 9-3)	1
40	PL1	048 573	LIGHT, ind red lens 28V	1
41		121 613	PANEL, front	1
42		605 583	CATCH, spring loaded door	1
43		134 327	LABEL, warning general precautionary	1
44		+121 465	DOOR, access front	1
		128 230	LABEL, warning electric shock can kill etc	1
45		109 013	BUSHING, snap-in nyl .375 ID x .562mtg hole	2
46			NAMEPLATE, (order by model and serial number)	1
47		107 983	BLANK, snap-in nyl .500mtg hole	1
48		097 924	KNOB, pointer	1
49		097 922	KNOB, pointer	2
50			PLATE, ident control rating (order by model and serial number)	1
51		078 034	FASTENER, screw sltd hd .736 lg	2

+When ordering a component originally displaying a precautionary label, the label should also be ordered.
BE SURE TO PROVIDE MODEL AND SERIAL NUMBER WHEN ORDERING REPLACEMENT PARTS.

Item No.	Part No.	Description	Quantity
046 746 Figure 9-3. Switch, Push Button (Fig 9-2 Item 39)			
1	059 885	BUTTON, push reset red	1
2	018 606	SPRING, cprsn .430 OD x .040 wire x 1.500	1
3	070 068	PUSH BUTTON SET, w/cable & housing	1
4	081 008	BRACKET, mtg switch PB	1
5	027 878	SWITCH, lim leaf actg SPDT	1

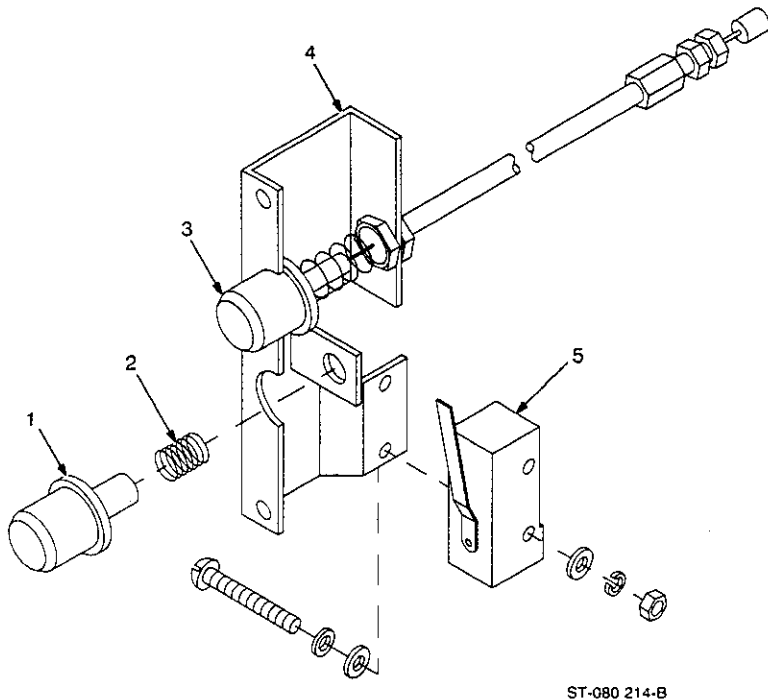

Figure 9-3. Switch, Push Button

ST-080 214-B

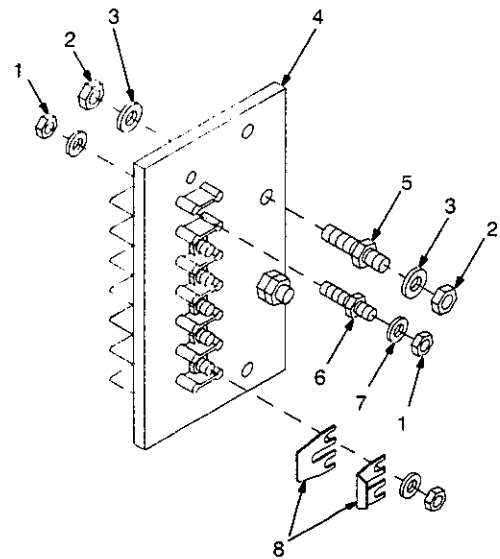

Figure 9-4. Terminal Assembly, Primary

ST-087 333-B

Item No.	Part No.	Description	Quantity
034 587 Figure 9-4. Terminal Assembly, Primary (Fig 9-1 Item 14)			
1	601 835	NUT, brs hex 10-32	12
2	601 836	NUT, brs hex .250-20 jam hvy	4
3	010 915	WASHER, flat brs .250 ID x .625 OD x .031thk	4
4	083 426	TERMINAL BOARD, pri	1
5	038 888	STUD, pri bd brs .250-20 x 1.500	2
6	038 887	STUD, pri bd brs 10-32 x 1.375	6
7	010 913	WASHER, flat brs .218 ID x .460 OD x .031thk	6
8	038 618	LINK, jumper term bd pri	2

BE SURE TO PROVIDE MODEL AND SERIAL NUMBER WHEN ORDERING REPLACEMENT PARTS.

Item No.	Dia. Mkgs.	Part No.	Description	Quantity
----------	------------	----------	-------------	----------

Figure 9-5. Panel, Rear w/Components (Fig 9-1 Item 23)

1	FM	116 190	MOTOR, 1/12hp 230V 1550RPM	1
2		087 462	BRACKET, mtg rectifier	2
3		131 361	CHAMBER, plenum 14 in	1
4		032 604	BLADE, fan 14 in 3wg 19deg .375 bore CCW	1
5		098 305	PANEL, rear	1
6	SR1	117 041	RECTIFIER, si diode (consisting of)	1
7	R9,VR2	044 482	SUPPRESSOR	1
8	D1,3	037 956	DIODE, rect 275A 300V SP	2
9	C4-7	031 689	CAPACITOR, rectifier	4
10	D2	037 957	DIODE, rect 275A 300V RP	1
	SCR1,2	107 588	THYRISTOR, SCR 300A 300V	2
		028 388	CLAMP, thyristor rectifier 2.750	2
		026 947	STAND-OFF, insul .250-20 x 1.000 lg x .312thd	2
		028 516	PIN, spring CS .125 x .250	4

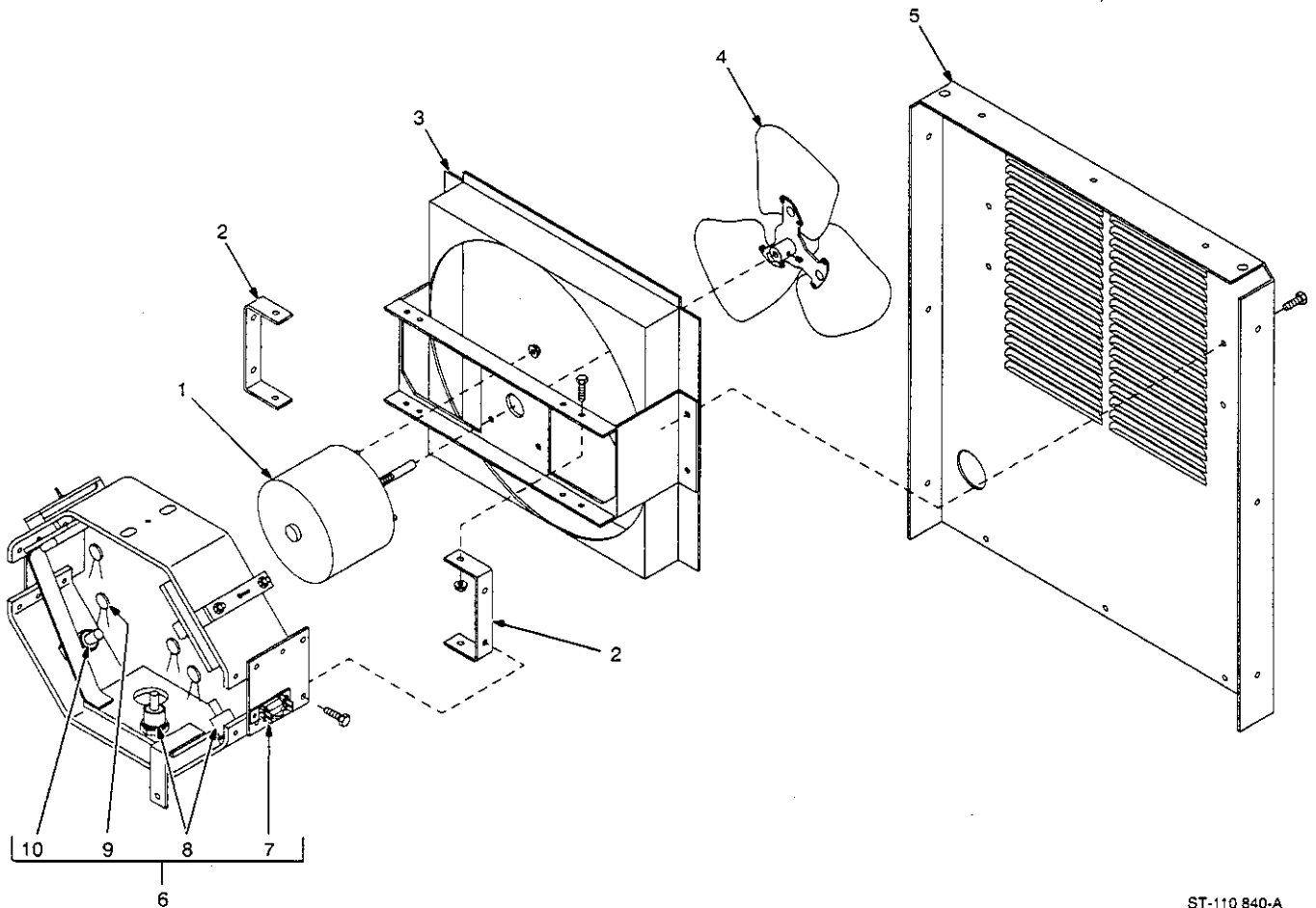

ST-110 840-A

Figure 9-5. Panel, Rear w/Components

BE SURE TO PROVIDE MODEL AND SERIAL NUMBER WHEN ORDERING REPLACEMENT PARTS.

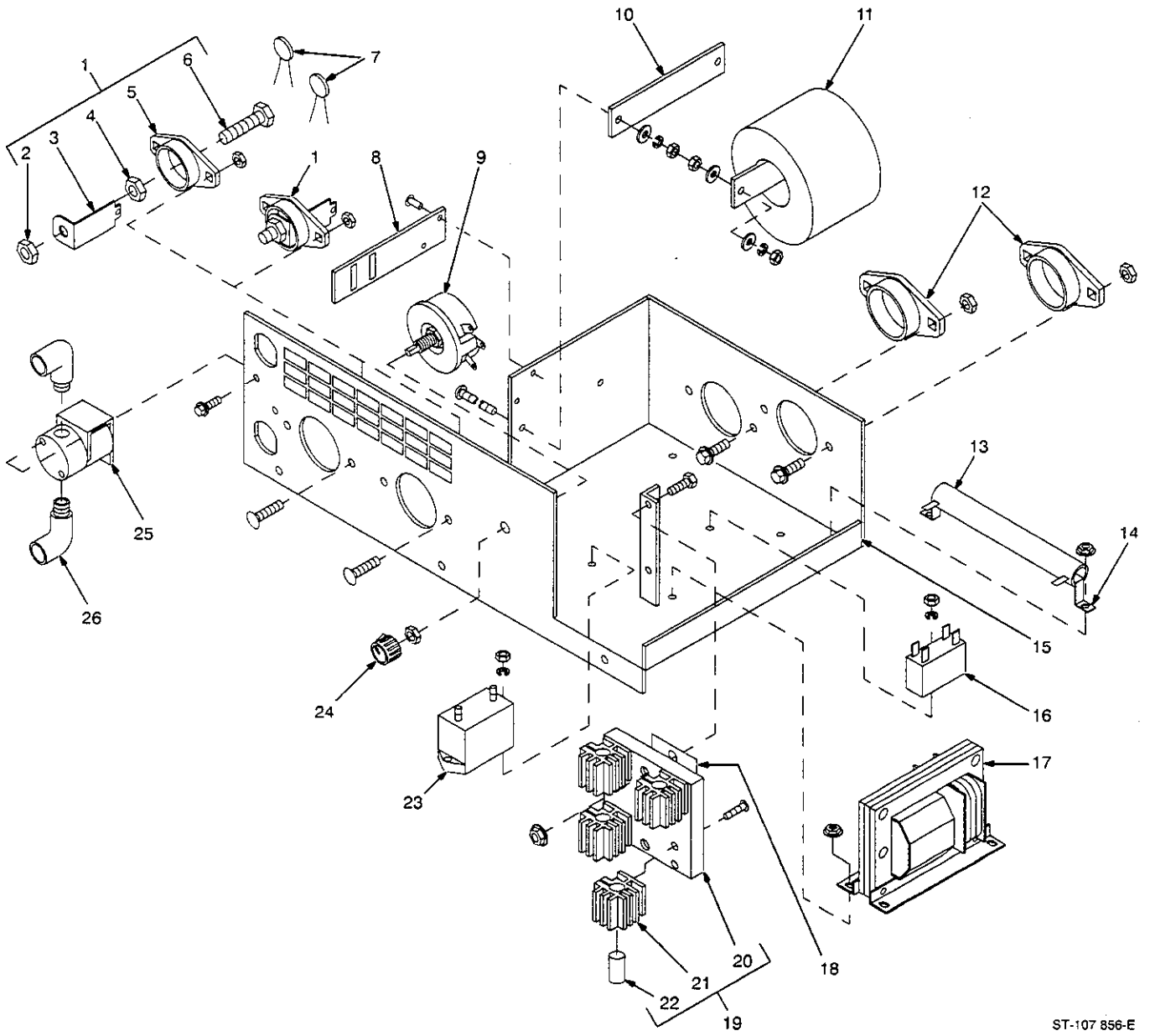

ST-107 856-E

Figure 9-6. HF Panel

Item No.	Dia. Mkgs.	Part No.	Description	Quantity
128 702 Figure 9-6. HF Panel (Fig 9-1 Item 32)				
.. 1		039 047	.. TERMINAL, pwr output red (consisting of)	2
.. 2		601 879	.. NUT, stl hex full .500-13	1
.. 3		039 044	.. BUS BAR, term bd	1
.. 4		601 880	.. NUT, stl hex jam .500-13	1
.. 5		039 049	.. TERMINAL BOARD, red	1
.. 6		601 976	.. SCREW, cap stl hexhd .500-13 x 1.500	1
.. 7	C18,19	147 869	.. CAPACITOR	2
.. 8		108 100	.. RETAINER, bus bar	1
.. 9	R7	605 828	.. RHEOSTAT, WW 50W 1.5 ohm	1
.. 10		124 649	.. STRIP, mtg HF coil	1
.. 11	T3	128 375	.. COIL, HF couplng air	1
.. 12		039 049	.. TERMINAL BOARD, red	2
.. 13	R3	083 784	.. RESISTOR, WW fxd 100W 10 ohm	1
.. 14		605 742	.. CLIP, mtg resistor .500 ID core	1
.. 15		128 580	.. ENCLOSURE, HF panel	1
.. 16	C3	106 935	.. CAPACITOR, polyp film 10uf 250VAC	1
.. 17	T2	074 398	.. TRANSFORMER, high voltage 115V pri 3600V sec 30mA	1
.. 18		107 219	.. STRIP, insulator	1
.. 19		020 623	.. SPARK GAP ASSEMBLY, (consisting of)	1
.. 20		095 621	.. BASE, spark gap	1
.. 21		020 622	.. HOLDER, points	4
.. 22	G	*020 603	.. POINT, spark gap	4
		602 023	.. SCREW, cap stl sch 10-24 x .750	4
.. 23	C13	096 761	.. CAPACITOR, mica .002uf 10000VDC	1
.. 24		097 922	.. KNOB, pointer	1
.. 25	GS1	+109 930	.. VALVE, 24VAC 2 way 1/4 IPS 1/8 orf	1
.. 26		+010 296	.. FITTING, hose brs elb M 1/4NPT x .625-18RH	2

*Recommended Spare Parts.

+These items are not part of HF Panel.

BE SURE TO PROVIDE MODEL AND SERIAL NUMBER WHEN ORDERING REPLACEMENT PARTS.

Dia. Mkgs.	Part No.	Description	Quantity
Optional Equipment			
	041 934	METER KIT, (consisting of)	1
	111 609	METER SET, AC (consisting of)	1
	108 956	PANEL, front meter box	1
	108 957	PANEL, rear meter box	1
	108 961	WRAPPER, meter box	1
V2	025 645	METER, volt AC 0-100 scale	1
A2	025 649	METER, amp AC 0-500 scale	1
P2	025 700	FILTER, HF AC amp meter	1
P1	025 701	FILTER, HF DC volt & amp meter	1
CT1	110 924	TRANSFORMER, current 500/5	1
	126 752	COVER, top	1
	010 493	BUSHING, snap-in nyl .625 ID x .875mtg hole	1
	041 936	METER KIT, (consisting of)	1
	111 610	METER SET, DC (consisting of)	1
	108 956	PANEL, front meter box	1
	108 957	PANEL, rear meter box	1
	108 961	WRAPPER, meter box	1
V1	025 638	METER, volt DC 0-100 scale	1
A1	025 664	METER, amp DC 50MV 0-500 scale	1
P1	025 701	FILTER, HF DC volt & amp meter	2
	126 752	COVER, top	1
Shunt	030 081	SHUNT, meter 50MV 500A	1
	010 493	BUSHING, snap-in nyl .625 ID x .875mtg hole	1
	041 938	METER KIT, (consisting of)	1
	111 611	METER SET, AC/DC (consisting of)	1
	108 959	PANEL, front meter box	1
	108 958	PANEL, rear meter box	1
	108 955	WRAPPER, meter box	1
V2	025 645	METER, volt AC 0-100 scale	1
V1	025 638	METER, volt DC 0-100 scale	1
A2	025 649	METER, amp AC 0-500 scale	1
A1	025 664	METER, amp DC 50MV 0-500 scale	1
P1	025 701	FILTER, HF DC volt & amp meter	3
P2	025 700	FILTER, HF AC amp meter	1
CT1	110 924	TRANSFORMER, current 500/5	1
Shunt	030 081	SHUNT, meter 50MV 500A	1
	126 752	COVER, top	1
	010 493	BUSHING, snap-in nyl .625 ID x .875mtg hole	2
	042 246	PRE-FLOW/SPOT TIMER, (consisting of)	1
PC2	157 844	CIRCUIT CARD, relay	1
CR1	107 524	RELAY, encl 12VDC 3PDT	1
PLG52	072 566	CONNECTOR, rect 8skt plug cable Amp 87159-8	1
	081 378	CONNECTOR, rect skt 22-18ga Amp102100-2	8
R59	028 768	POTENTIOMETER, C sltd sft 1/T 2W 350K ohm	1
	097 922	KNOB, pointer	1
S7	011 609	SWITCH, tgl SPDT 15A 125VAC	1

BE SURE TO PROVIDE MODEL AND SERIAL NUMBER WHEN ORDERING REPLACEMENT PARTS.

OPTIONS AND ACCESSORIES

ANALOG METER KITS

Includes voltmeter and ammeter housed in metal case, which mounts on top of power source. Meters RF protected.

Type	Factory	Field
DC	(#041 936)	(#041 937)
AC	(#041 934)	(#041 935)
AC/DC	(#041 938)	(#041 939)

PREFLOW/SPOT TIMER

(#042 246 Factory)

(#042 247 Field)

Includes an adjustable spot time of 0 to 5 seconds, and a fixed preflow time of approximately 2 seconds.

WATER VALVE KIT

(#042 038 Field only)

NO. 20 RUNNING GEAR

(#041 581)

Four 8 in. (203 mm) poly/rubber blend wheels with 30 in. (762 mm) towing handle.

NO. 5CR CYLINDER RACK

(#041 584)

Used with No. 20 running gear.

NO. 3WA WELDING

ACCESSORIES

(#040 043)

35 ft. (10.6 m) No.1/0 electrode cable with electrode holder and lug attached, 30 ft. (9 m) No.1/0 work cable with lugs attached, welding helmet, and wire scratch brush.

REMOTE CONTROLS AND SWITCHES

RHC-14 HAND CONTROL

(#129 340)

Miniature hand control for remote current and contactor control. Dimensions: 4 in. (102 mm) x 4 in. (102 mm) x 3-1/4 in. (82 mm). Includes 20 ft. (6 m) cord and 14-pin Amphenol plug.

RFC-14 FOOT CONTROL

(#129 339)

Foot current and contactor control. 20 ft. (6 m) cord and 14-pin Amphenol plug.

RMLS-14 SWITCH

(#129 337)

Momentary- and maintained -contact rocker switch for contactor control. Push forward for maintained contact and back for momentary contact. Includes 20 ft. (6 m) cord and 14-pin Amphenol plug.

FTC-14

(#129 338)

Remote fingertip control can be taped to TIG torch, contactor and current control. Includes 28 ft. (8.5 m) cord and 14-pin plug. Pre-wired.

EXTENSION CABLES FOR 14-PIN REMOTE CONTROLS

(#122 972)	10 ft. (3 m)
(#122 973)	25 ft. (7.6 m)
(#122 974)	50 ft. (15.2 m)
(#122 975)	75 ft. (22.9 m)

WELDING TORCHES

MT-18, 350 AMPS (MAX.)

For hand-held manual applications.

Only available with "bonded" tri-flex cable assembly.

Explanation of Model Description

MT	= Miller Torch
18	= 350 Amps
12	= 12 ft. (3.8 m) cable
25	= 25 ft. (7.6 m) cable
V	= Gas Valve

Note: Water-cooled torches require power cable adapter (#116 228).

MT-18 Models

(#116 151)	MT-18-12
(#116 152)	MT-18-25
(#116 153)	MT-18V-12
(#116 154)	MT-18V-25

Includes torch body with handle, 300HS heat shield, long backcap, and cable assembly.

MT-18 TORCH KIT

(#129 592)	12-1/2 ft. (3.8 m)
(#129 591)	25 ft. (7.6 m)

Includes hose and hardware hook-up kit (THK-1), consumable accessory kit (TAK-3), regulator/flowmeter (HRF-2425), ground cable with clamp, and power cable adapter.

WATER COOLANT SYSTEMS

For detailed information regarding coolant systems, refer to Literature Index NO. AY/7.2.

COOLMATE™ 4

(#042 288) 115 VAC, 50/60 Hz

(#042 289) 230 VAC, 50/60 Hz

4 gal. (15.1 L) tank capacity. Used with water-cooled torches rated up to 600 Amps.*

RADIATOR 1A AND 2A

(#042 492) Radiator 1A, 115

VAC

(#042 493) Radiator 2A, 230

VAC

1.5 gal. (5.7 L) tank capacity. Used with water-cooled torches rated up to 500 Amps.*

WATERMATE™ 1A AND 2A

(#042 495) Watermate 1A, 115 VAC

(#042 496) Watermate 2A, 230 VAC

2 gal. (7.6 L) tank capacity. Used with water-cooled torches rated up to 500 Amps.*

**Note: This may vary, depending on the torch design and cable length.*

SUGGESTED WIRE FEEDER

(Spray Transfer)

S-32S VOLTAGE SENSING WIRE FEEDERS

Refer to Literature Index No. M/6.21.

SPOOLMATIC® 30A

(#130 831)

200 Amp, 100% duty cycle, air-cooled 1 lb. spool gun with 30 ft. (9.1 m) cable assembly.

WC-115A WELD CONTROL

(#137 546)

Designed for use with the Spoolmatic 30A spool gun and a DC power source having only 115VAC available.