

# **ELECTRIC COUNTER TOP GRIDDLE WITH CHEESEMELTER**

## **OPERATION MANUAL**

**EL-1624T**

**EL-1636T**



**EL-1624T Shown**



# **CECILWARE CORPORATION**

43-05 20<sup>th</sup> AVENUE, LONG ISLAND CITY, NEW YORK 11105-1295 ■

718-932-1414

FAX 718-932-7860

[www.cecilware.com](http://www.cecilware.com)

# **TABLE OF CONTENTS**

<b>Introduction .....</b>	<b>page 2</b>
<b>Packaging .....</b>	<b>page 2</b>
<b>Installation .....</b>	<b>page 2</b>
<b>Operation .....</b>	<b>page 3</b>
<b>Cleaning, Care and Maintenance .....</b>	<b>page 3</b>
<b>Safety .....</b>	<b>page 4</b>
<b>Trouble Shooting .....</b>	<b>page 4-5</b>
<b>Compliance .....</b>	<b>page 5</b>
<b>Electrical Diagram .....</b>	<b>page 6</b>
<b>Explosion View .....</b>	<b>page 7-8</b>
<b>Spare Part List .....</b>	<b>page 9</b>
<b>Specifications .....</b>	<b>page 10</b>

## **Introduction**

Congratulations on the purchase of your Cecilware Griddle/Cheesemelter. Please take a few moments to carefully read through this manual to ensure that the machine is operated and maintained properly. This will enable the best possible performance from this product for many years.

Cecilware will not accept liability for the following if:

- \* The instructions in this manual have not been followed correctly.
- \* Non-authorized personnel have tampered with the machine.
- \* Non-original spare parts are used.
- \* The machine has not been handled and cleaned correctly.

## **Packaging**

Cecilware prides itself on quality and service, ensuring that at the time of packing all products are supplied fully functioning and free of damage.

Provided in this package are the following:

- \* Griddle/Cheesemelter
- \* Grilling Rack
- \* Crumb Tray
- \* Drip Tray
- \* Manual

Should you find any damage that occurs in transit, please contact your Cecilware dealer immediately.

## **Installation**

Remove the Cecilware Griddle/Cheesemelter from the packaging. Be certain that all protective plastics and residues are thoroughly cleaned from its surface.

Place the Cecilware Griddle/Cheesemelter on a firm level surface; the adjustable feet can assist in leveling.

Local standards and regulations should be consulted in order to abide by standards set in relation to positioning, spacing and ventilation. Cecilware recommends that you allow no less than 4" ventilation gap around the perimeter of this unit. Common sense and initiative should be used when choosing a position and operating of this product.

### **Caution:**

Do not position or operate near combustible materials/flammable objects.

Once your Griddle/Cheesemelter has been placed into position, be sure that the stainless steel waste and crumb trays have been correctly positioned.

Supply the appropriate power and connect to source; your Griddle/Cheesemelter is now ready to turn on and operate. (For power supply, please see technical specification sheet, page 10)

### **Preparing the cooking surface:**

Be sure the cooking surface is clean; then simply turn the unit on and apply a generous amount of oil to the plates, using the thermostat setting of 230° F for the grill. Once the grill has reached that temperature, switch off and wipe the plates clean of excess oil.

The Cheesemelter part of this unit does not need any preparation; it is ready to use.

**Caution: The grill and oil will be HOT!!!!!!**

## **Operation**

Your Griddle/Cheesemelter should be turned on prior to usage to allow the cooking surface to warm up; 5 minutes should be sufficient.

To get efficient use out of this unit while in intermittent use, it is recommended that the thermostat be turned down, when not cooking. This will assist in reducing power consumption and also allow for a quicker heating response when needed.

Cecilware recommends that the cooking surface be lightly greased before each use. For cheesemelting or finishing, simply adjust the grilling grid to your needs beneath the hotplate and element.

Turn the thermostat dial towards the "ON" position. The amber pilot light will activate to confirm this; adjust the dial to the required setting. As the grill plate fluctuates in temperature, the thermostat will operate to maintain set temperature and the light will continue to indicate when the elements are heating or have reached the required temperature. Both the cheesemelter and the grill plate run off the one element and thermostat.

A temperature setting of between 375° F and 430° F will be sufficient for general cooking. This may vary for a particular food type, individual needs, or experience.

Simply place the food products on the grilling surface and cook to your needs. For cheesemelting or finishing, place the food products on the grilling grid supplied and slide into the unit.

## **Cleaning, Care and Maintenance**

\*Switch the power off and disconnect from power source when cleaning.

\*The Griddle/Cheesemelter should be cleaned regularly throughout use, and thoroughly cleaned after each meal period. Regular cleaning will result in easier cleaning, as the build up of waste food particles will be less. Correct preparation of the cooking surface when first used will assist in keeping the plates clean.

\*For best results, clean the plates while still warm using warm soapy water. A nylon cleaning cloth can be used, but it is recommended that steel wool etc. be avoided, as they will damage the plates. **Do not** use cold water on warm plates; a buckling effect may occur.

\*When scrubbing the plates, take care not to clean back too far. If you do, you may have to prepare the cooking surface again before use.

\*Remove the waste and crumb trays from unit and discard waste; clean in hot soapy water.

\*The remainder of the Griddle/Cheesemelter can be cleaned with a damp cloth using hot, soapy water.

\*Warm soapy water is recommended for cleaning, cleaning agents after prolonged use can damage stainless steel.

## **Safety**

\*A Cecilware Recommended Qualified Service Technician should carry out repairs if necessary. Do not remove any components or service panels on this product.

\*Switch off power to and disconnect from the power source while cleaning.

\*Allow the Griddle/Cheesemelter to cool down after using before dismantling for cleaning; the unit will still be too hot to handle immediately after use

\*Do not immerse in water or use hose to clean.

\*If the power cord is damaged, it must be replaced by a Cecilware Recommended Qualified Service Technician in order to avoid a hazard.

## **Trouble Shooting**

If your Cecilware Griddle/Cheesemelter does not operate, please check the following before placing a service call.

<b>Griddle with Cheesemelter</b>	<b>EL-1624T, EL-1636T</b>	
<b>Problem</b>	<b>Cause</b>	<b>Remedy</b>
The unit is not working and the indicator light is not on	1. Mains power supply	1. Check mains power supply
	2. Power switch has not been turned on	2. Check the unit is correctly plugged in and turned on
	3. Fuse in the plug has blown	3. Replace the fuse in the plug with correctly rated fuse
	4. Plug and lead are damaged	4. Call service agent or qualified technician
	5. Internal wiring fault	5. Call service agent or qualified technician
	6. Thermal cut-out has activated	6. This is a safety device that has disconnected the power: call a service agent or qualified technician
The unit is heating but the indicator light is not on	1. The indicator bulb has blown	1. Replace the indicator light: call a service agent or qualified technician

**Trouble Shooting Cont...**

<b>Problem</b>	<b>Cause</b>	<b>Remedy</b>
Indicator light is on but the unit is not heating	1. Faulty element(s)	1. Call service agent or qualified technician
	2. Operation of thermostat	2. Ensure that the thermostat is set correctly, also ensure the dial is not spinning on the thermostat and giving the wrong reading
	3. Faulty thermostat	3. Call service agent or qualified technician
Slow heat up of the cooking surfaces	1. Carbon build up	1. Ensure that the plates are kept clean and free of carbon build up
	2. Thermostat setting	2. Ensure that the thermostat is set correctly, also ensure the dial is not spinning on the thermostat and giving the wrong reading
	3. Faulty element(s)	3. Call service agent or qualified technician

Please ensure:

- \*There is correct power supply.
- \*The machine is plugged in correctly and power is switched on.
- \*The timer and thermostat are in the correct position.
- \*The elements are clear of any food waste.

Note: All Cecilware products are tested prior to packing.

**Compliance**

Cecilware products have undergone strict product testing in order to comply with regulatory standards and specifications set by international, independent, and federal authorities.

As testimony to such compliance, Cecilware products carry the following marks/symbols:



**Electrical Diagram**

Model: EL-1624T:

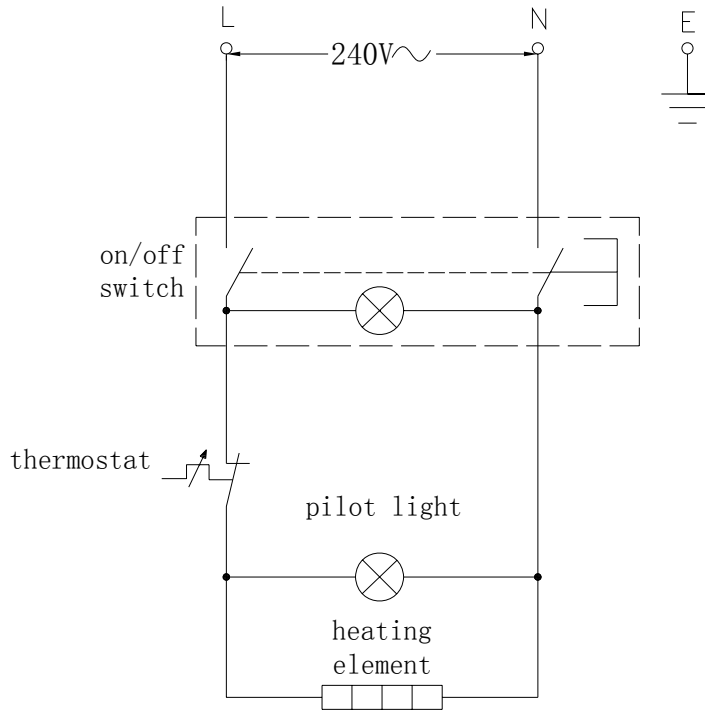

EL-1636T:

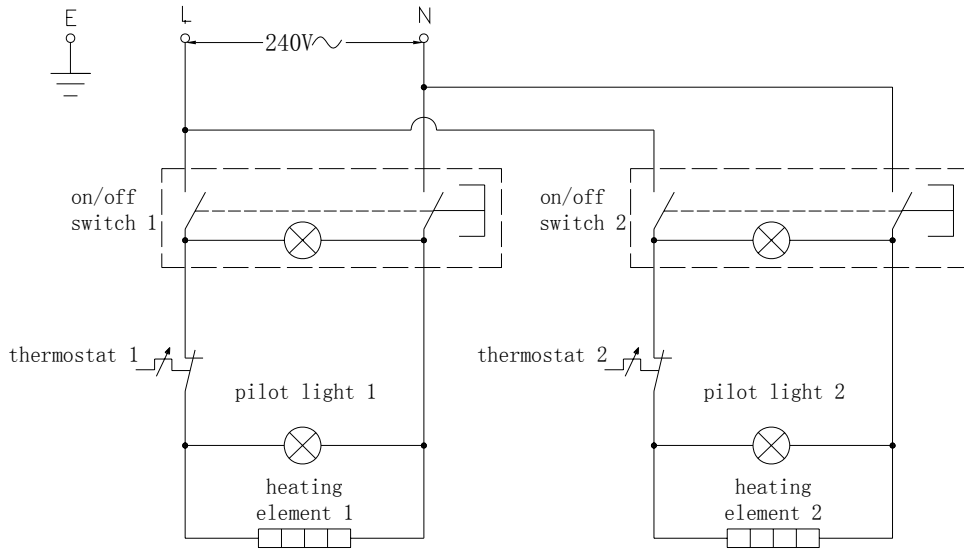

The above circuit diagram has been provided to assist qualified technicians. A Recommend Qualified Service Technician should carry out repairs if needed. Do not remove any components or service panels on this product.

**Explosion View**

**MODEL: EL -1624T**

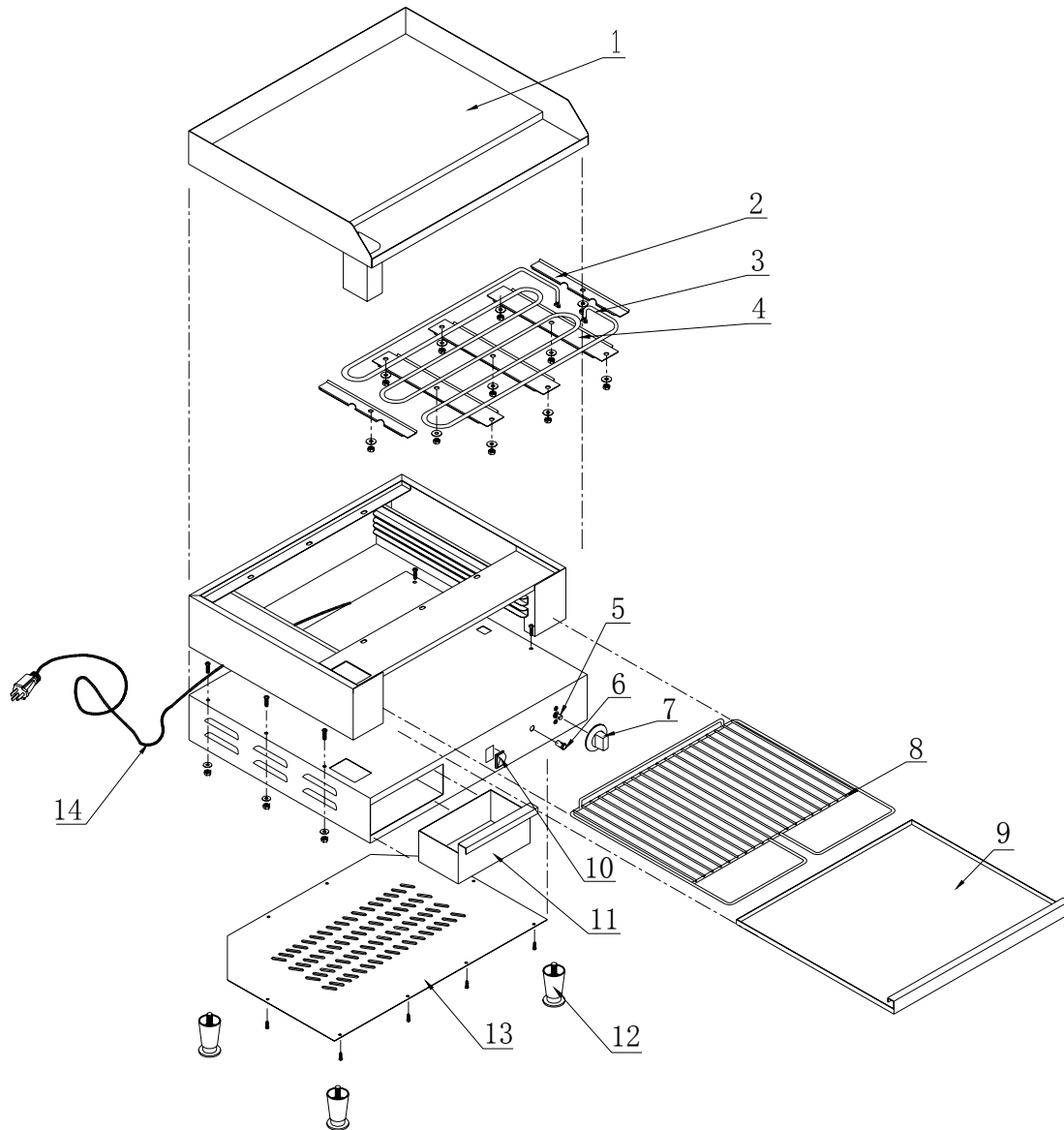



MODEL: EL – 1636T

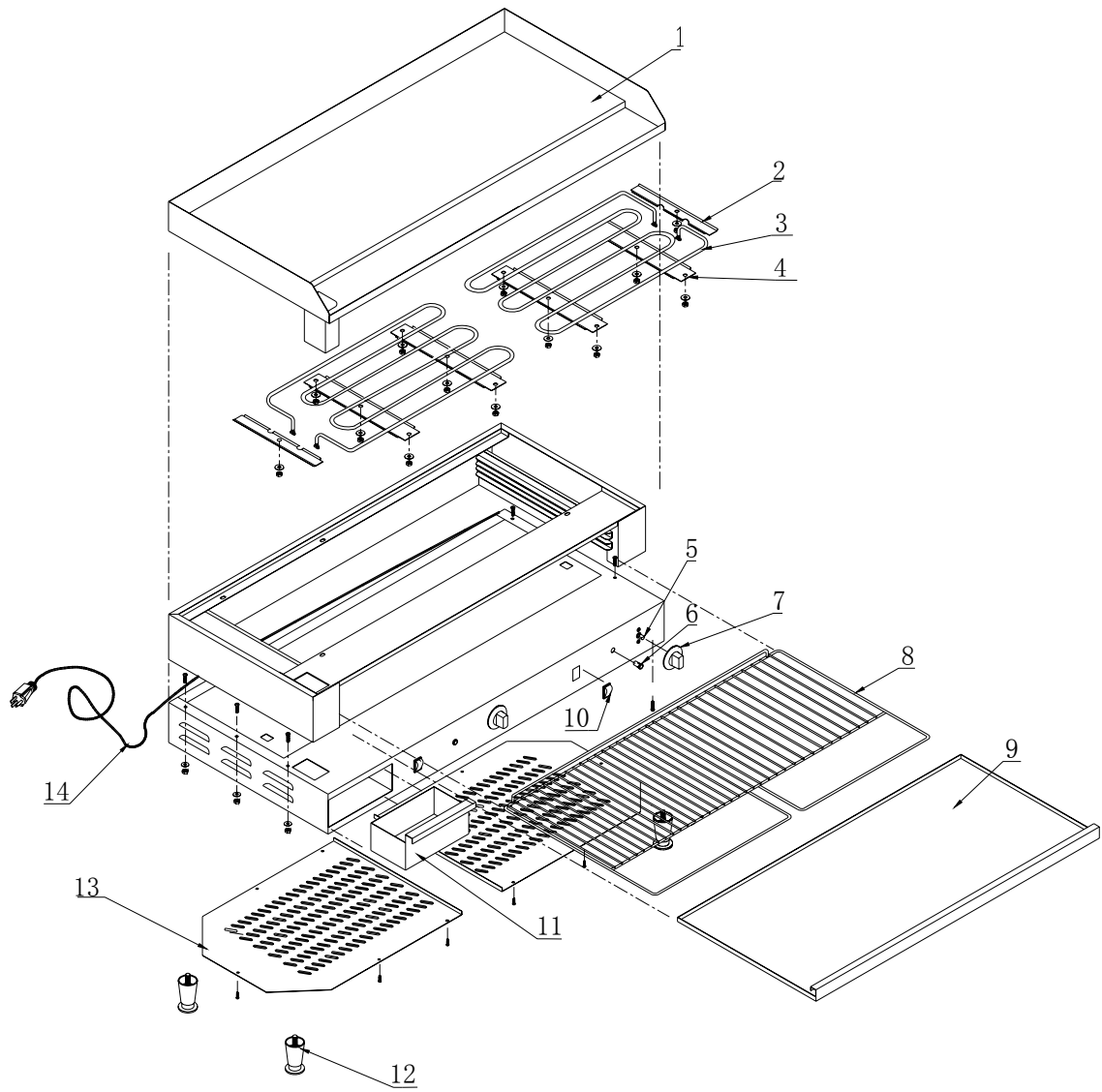

**Spare Parts List**

		EL-1624T		EL-1636T	
No.	Description	QTY	Part NO.	QTY	Part NO.
1	GRIDDLE PLATE	1	NA	1	NA
2	ELEMENT CLAMP (UPPER)	2	NA	2	NA
3	ELEMENT FIXING PALTE	1	08036	2	08043
4	ELEMENT CLAMP (LOWER)	3	NA	4	NA
5	THERMOSTAT	1	08078	2	08078
6	PILOT LIGHT	1	08067	2	08067
7	THERMOSTAT DIAL	1	08041	2	08041
8	GRILLING RACK	1	08037	1	08044
9	CRUMB TRAY	1	08038	1	08045
10	ON/OFF SWITCH	1	08054	2	08054
11	DRIP TRAY	1	08039	1	08039
12	FEET	4	080040	4	08040
13	BASE PLATE	1	NA	2	NA
14	CORD AND PLUG	1	08047	1	08047

\*NA = not available except by special order.

**Specifications**

<b>CECILWARE MODEL</b>	<b>VOLTAGE</b>	<b>POWER (watts)</b>	<b>DIMENSIONS (inches) W×D×H</b>
EL-1624T	240V 60HZ	2400	24" × 22" × 12 1/4"
EL-1636T		3600	36" × 22" × 12 1/4"



# **CECILWARE CORPORATION**

43-05 20<sup>th</sup> AVENUE, LONG ISLAND CITY, NEW YORK 11105-1295 ■

718-932-1414    FAX 718-932-7860    [www.cecilware.com](http://www.cecilware.com)