

Operation guide

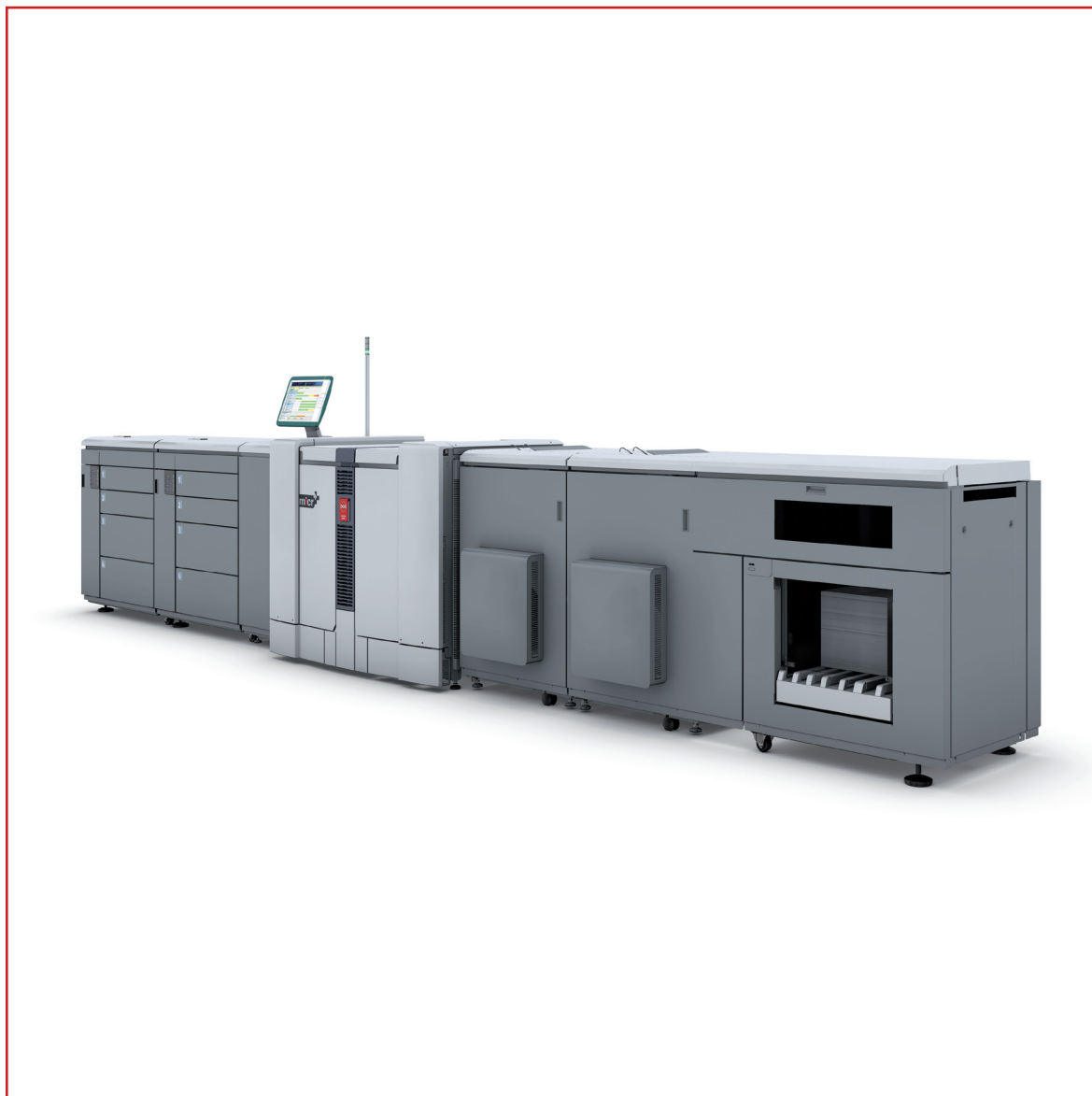

Océ VarioPrint® 6000 MICR+ line



Canon
CANON GROUP

Copyright

© 2011-2013, Océ

All rights reserved. No part of this work may be reproduced, copied, adapted, or transmitted in any form or by any means without written permission from Océ.

Océ makes no representation or warranties with respect to the contents hereof and specifically disclaims any implied warranties of merchantability or fitness for any particular purpose.

Furthermore, Océ reserves the right to revise this publication and to make changes from time to time in the content hereof without obligation to notify any person of such revision or changes.

Trademarks

List of trademarks

Océ, VarioPrint, PRISMAaccess, PRISMAprepare, PRISMAproduction and DPLink are registered trademarks of Océ-Technologies B.V.

Xerox, DocuTech, DigiPath and FreeFlow are registered trademarks of Xerox Corporation.

Adobe and PostScript are registered trademarks of Adobe Systems Incorporated.

Products in this publication are referred to by their general trade names. In most, if not all cases, these designations are claimed as trademarks or registered trademarks of their respective companies.

Contents

Chapter 1

Introduction	7
Notes for the reader.....	8
Introduction to the Océ VarioPrint® 6000 MICR+ line.....	9
Introduction to the main system components.....	10
Available documentation.....	12

Chapter 2

Transaction printing	13
Introduction to the Transaction section	14
Output recovery in case of an error.....	17
Activate transaction printing.....	20
Deactivate transaction printing.....	21
Activate the MICR mode.....	22
Shift the image in the transaction printing mode.....	24
Handle the media messages - How to handle the Media message in the tray-to-tray mode.....	25
Handle the media messages - How to handle the Media message in the tray-to-media mode.....	26
Create a transaction setup - How to create a new transaction setup.....	27
Create a transaction setup - How to change the IPDS parameters.....	27
Create a transaction setup - How to change the PCL parameters.....	29
Create a transaction setup - How to modify a transaction setup.....	30

Chapter 3

MICR fonts	31
MICR fonts.....	32

Chapter 4

MICR Toner	33
Check the status of the toner reservoirs.....	34
Add toner.....	35

Appendix A

Miscellaneous	37
Product specifications.....	38

Index	41
--------------------	-----------

Chapter 1

Introduction

Notes for the reader

Introduction

This manual helps you to use the Océ VarioPrint® 6000 MICR+ line. The manual contains a description of the product and guidelines to use and operate the Océ VarioPrint® 6000 MICR+ line.

Definition

Attention-Getters





Parts of this manual require your special attention. These parts can provide the following:

- Additional general information, for example, information that is useful when you perform a task.
- Information to prevent personal injuries or property damage.

Symbols used in this manual

The following symbols are used in this manual to explain procedures, restrictions, handling precautions, and instructions that should be observed for safety.

Overview of the attention-getters

Word	Icon	Indicates
WARNING		Indicates a warning concerning operations that may lead to death or injury to persons if not performed correctly. To use the machine safely, always pay attention to these warnings.
CAUTION		Indicates a caution concerning operations that may lead to injury to persons if not performed correctly. To use the machine safely, always pay attention to these cautions.
IMPORTANT		Indicates operational requirements and restrictions. Be sure to read these items carefully to operate the machine correctly and to avoid damaging the machine or property.
NOTE		Indicates a clarification of an operation or contains additional explanations for a procedure. Reading these notes is highly recommended.
		Indicates an operation that must not be performed. Read these items carefully and make sure not to perform the described operations.

Introduction to the Océ VarioPrint® 6000 MICR+ line

Introduction

The Océ VarioPrint® 6000 MICR+ line is a series of high-volume, cut-sheet printers. These printers support magnetic ink character recognition (MICR). MICR printing is intended primarily for transaction printing of valuable documents like cheques. A magnetic reader can read documents printed with MICR toner.

The Océ VarioPrint® 6000 MICR+ line uses the Océ Gemini Instant Duplex Technology. This technology enables the machine to print MICR toner on both the front side and the back side of a sheet at the same time. Depending on your version, the sustained print speed ranges from 170, 200 to 250 images per minute (A4 / Letter) when you print a 2-sided document. The print speed for 1-sided documents (A4/Letter) is 125 images per minute.

The Océ VarioPrint® 6000 MICR+ line prints only with MICR toner. A combination of MICR toner and regular toner is not possible. However, you can also print regular documents with MICR toner.

This section gives a short description of the main features of the printer.

Overview of the main features

- Support of magnetic ink character recognition (MICR) printing
- Océ Gemini Instant Duplex Technology that enables the printing of both sides of a sheet at the same time.
- Advanced scheduling concept on the operator panel to keep the machine running.
- Load and assign the media while the printer prints.
- Unload the media while the printer prints
- Assign the media while the printer warms up, after the printer is initialized.
- Support of up to 12 paper trays (total input capacity up to 13,800 sheets) and a roll feeder.
- Support of up to 3 stackers, a finisher and other external finishers.
- Support of a large range of media, media sizes and media weights.
- Support of secure printing.
- Support of IPDS/PS/PCL/PDF and streaming PS.
- Support of a large range of software products, for example the Océ PRISMA series, Xerox® FreeFlow®.
- Support of RDO files via Océ DP Link.

Introduction to the main system components

Introduction

The following illustration shows the main system components. The table describes the main components.

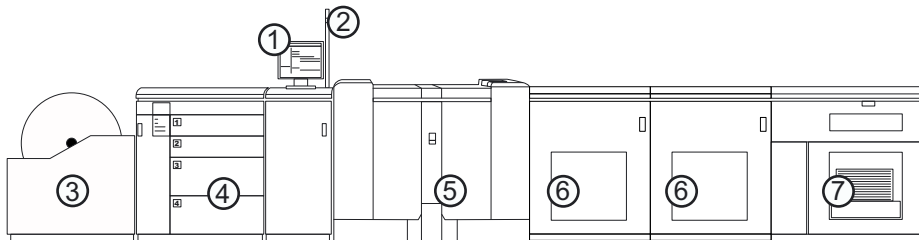

[1] The main system components

The main system components

	Component	Function
1	Operator panel	The operator panel helps you with your daily work, for example the scheduling of the jobs. Furthermore, the operator panel helps you solve errors or perform maintenance tasks.
2	Operator attention light	The operator attention light enables you to check the status of the system from a distance.
3	Roll feeder (optional)	A roll feeder is an optional device that adds paper input capacity to your printer. When you use a roll feeder, you can only use 1 or 2 paper modules. A combination of 3 paper modules and a roll feeder is not possible. The operator panel displays the roll feeder and gives feedback about the status of the roll feeder. For example whether the roll is full or empty. Please refer to the documentation of the roll feeder manufacturer for more information, for example about replacing an empty roll.
4	Paper module	The paper module contains 4 paper trays. The paper trays contain the media that will be printed. The default configuration of the system contains 1 paper module. You can add 1 or 2 additional paper modules to the default configuration to increase the media input capacity.
5	Engine module	The engine module contains the components that print the media. Access to the engine module is only required when a paper jam occurs or when maintenance is required. The doors at the left-hand side and right-hand side of the engine module give access to the toner units.
6	PrintGuard modules	The PrintGuard modules are required for MICR printing. The PrintGuard modules postfuse the prints. ▶

	Component	Function
7	Stacker	The stacker is the output location of a default configuration. The system supports up to 3 stackers.

Available documentation

Introduction

This machine is delivered with a documentation set that consists of the following items.

- A 'Safety Information Sheet'.
- A 'Documentation Notice'.

You can find and download the user manuals on global.oce.com.

User manuals	Availability
User manual - Operating information (MICR printing)	Available as a PDF file (English only).
User manual - Operating information (Document printing)	Available as a PDF file in multiple languages.
User manual - Maintenance tasks	Available as a PDF file in multiple languages.
User manual - Safety information	Available as a PDF file in multiple languages.



NOTE

Please check global.oce.com for the latest version of the documentation.

Main Content of the User Manuals

The following table provides an overview of the main content of the user manuals.

Main Content of the User Manuals

User Manual	Main content
Operating information (MICR printing)	<ul style="list-style-type: none"> • Introduction to MICR Printing • Printing with MICR • Add toner
Operating information (Document printing)	<ul style="list-style-type: none"> • Overview of the main system components • Working with the operator panel • Handling and managing jobs on the operator panel • Optional finishers and other devices • Add media, toner and staples
Maintenance tasks	<ul style="list-style-type: none"> • Replacing parts • Cleaning parts • Solve a paper jam in the engine module
Safety information	<ul style="list-style-type: none"> • Instructions for safe use

Chapter 2

Transaction printing

Introduction to the [Transaction] section

Introduction



NOTE

Transaction printing requires a license. The [System] view on the operator panel displays the [Transaction] section only when transaction printing is licensed.

Transaction printing enables you to print typical transactional documents like invoices, salary slips or other variable data streams. Before you can start transaction jobs, you must first activate the transaction mode via the operator panel. The [Transaction] section contains the settings that you need to use transaction printing. There you can also shift the image in case of a misalignment.

The following information is described below.

- An overview of the items in the [Transaction] section on the operator panel.
- The sequence of steps you must perform to print your transaction jobs.

Overview of the [Transaction] section

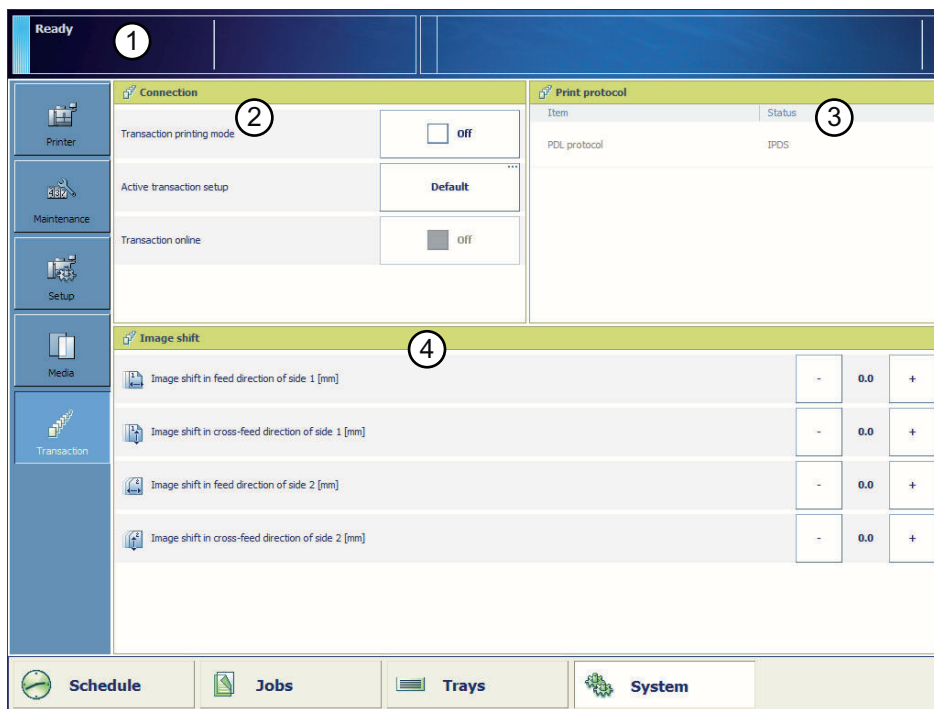

[2] Overview of the [Transaction] section

The items of the [Transaction] section

Description of the [Transaction] section

Number	Item	Function
1	Dashboard	The dashboard displays the following information for transaction printing. <ul style="list-style-type: none"> • The connection status • The IP address of the host that sends the jobs • The name of the active transaction job • The progress of the active transaction job
2	[Connection]	The [Connection] section gives access to the following functions. <ul style="list-style-type: none"> • Turn the transaction printing mode on or off • Select the setup for the transaction jobs You can define setups in the Settings Editor ([Transaction printing] -> [Setups]). • Put the printer online or offline. The printer must be online for the host to be able to connect to the printer.
3	[Print protocol]	Display the active printer description language (read-only). You can change the active PDL in the Settings Editor ([Transaction printing] -> [Settings] -> [Requested active PDL]). When the requested active PDL is changed, the new PDL becomes effective when you put the printer online.
4	[Image shift]	Display and change the active image shift settings, for example when the images on the front and back of a sheet are not aligned correctly.

Sequence of steps to print transaction jobs



NOTE

Before you begin, the list of [Scheduled jobs] must be empty.

The following table describes the sequence of steps for transaction printing.

Step	Actions on the printer	Actions on the host	Remarks
1	Switch the printer into the transaction printing mode.		Via the operator panel: [System] -> [Transaction] -> [Transaction printing mode] -> [On].
2	Select the active setup that you need.		<ul style="list-style-type: none"> • Via the operator panel: [System] -> [Transaction] -> [Active transaction setup], or • Via the Settings Editor: [Transaction printing] -> [Setups], or • By the host via the data stream (when the printer is online and connected).

Step	Actions on the printer	Actions on the host	Remarks
3	Change the active PDL when currently the wrong PDL is active. This is only possible when you have licenses for more than 1 PDL.		Via the Settings Editor: [Transaction printing] -> [Setups] -> [Requested active PDL].
4	Load the required media into the paper trays.		Only required when the active setup has set the tray mode to tray to tray.
5	Put the printer online.		<ul style="list-style-type: none"> • Via the operator panel: [System] -> [Transaction] -> [Transaction online] -> [On], or • Via the Settings Editor: [Transaction printing] -> [Settings] -> [Switch the printer online or offline].
6		Connect to the printer.	
7		Submit the transaction print jobs.	
8	Print the transaction print jobs.		You must perform all the regular activities, for example load the media, empty the output locations, add the supplies and solve errors.
9	Put the printer offline when the transaction print jobs are ready.		<ul style="list-style-type: none"> • Via the operator panel: [System] -> [Transaction] -> [Transaction online] -> [Off], or • Via the Settings Editor: [Transaction printing] -> [Settings] -> [Switch the printer online or offline].
10	Switch the printer back to the document printing mode.		<ul style="list-style-type: none"> • Via the operator panel: [System] -> [Transaction] -> [Transaction printing mode] -> [Off].

Output recovery in case of an error

Introduction



The Océ VarioPrint® 6000 MICR+ line is equipped with an efficient, reliable output recovery in case of an error. By factory default, the output recovery is set to [Normal]. After the error is solved, the job continues at the page where the error occurred automatically.

However, some printing environments require that multiple copies must be avoided. For example, in transactions involving the printing of valuable documents such as cheques. In such an environment, the [Output recovery] setting of your IPDS setup must be set to [Suppressed].

When the output recovery is suppressed, the printer will not automatically recover output. All pending pages in the printer will be deleted and the stack will be ejected. The host system and the operator are responsible for the recovery. The operator must restart the job manually on the correct page.

The tables below describe what happens when either the normal output recovery or the suppressed output recovery is selected.

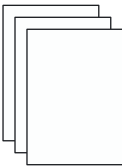
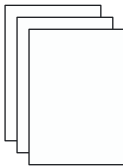
Normal output recovery in IPDS

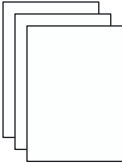
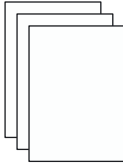

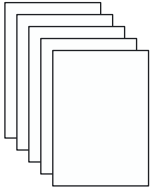
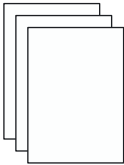
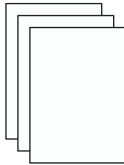
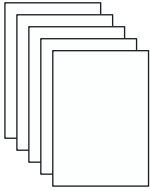
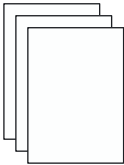
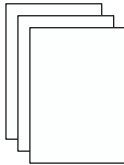

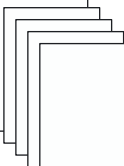
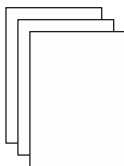

Job	Job progress states	Normal output recovery	End up in the output location after error recovery
	 Sheets printed successfully.	Are stacked at one of the output locations.	 Sheets are in output location
	 Sheets copied to controller memory (including error pages).	Remain in controller memory.	 Once the error is resolved, the printer restarts by printing the first page in the controller memory.

Job	Job progress states	Normal output recovery	End up in the output location after error recovery
	 Sheets jammed in the machine.	The operator panel displays instructions on how to solve the paper jam. The operator has to remove these the jammed sheets manually.	 These sheets stay in the memory of the controller. Once the printer resumes printing, these pages will be printed again.
	 Sheets in host memory.	Remain in host memory.	 These sheets stay in the host memory. When the printer starts printing, these pages will be copied and sent to the controller.

Suppressed output recovery in IPDS

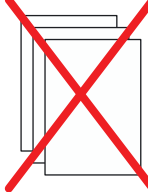
Pages that are copied to the memory of the controller are deleted from the system. The operator must send these missing pages as a new transaction print job to the printer.

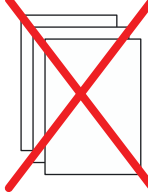
Job	Job progress states	Suppressed output recovery	End up in the output location after error recovery
	 Sheets printed successfully	Are stacked at one of the output locations.	 Sheets are in output location

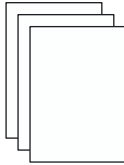
Job	Job progress states	Suppressed output recovery	End up in the output location after error recovery
	 Sheets copied to controller memory (including error pages).	Are deleted completely.	 These sheets are not delivered to the output location.
	 Sheets jammed in the machine.	The operator panel displays instructions on how to solve the paper jam. The operator has to remove these the jammed sheets manually.	 These sheets are not delivered to the output location.
	 Sheets in host memory.	Remain in host memory.	 Once the error is resolved, the printer restarts by printing the first page in the host memory.

Activate transaction printing

Before you begin

Make sure that the list of [Scheduled jobs] is empty.

Procedure

1. On the operator panel, touch [System] -> [Transaction] -> [Transaction printing mode].
The text on the button changes from [Off] to [On].
2. If required, touch [Active transaction setup] and select the desired setup.
The attributes of the transaction setup are defined in the Settings Editor on the PRISMAsync controller.
3. Load the required media into the paper trays if the setup selects the tray-to-tray mode.
4. Touch [Transaction online] to put the printer online.
The text on the button changes from [Off] to [On].
5. On the host or mainframe, connect to the printer and start the job.



NOTE

You can also select a setup and put the printer online via the [Transaction printing] section in the Settings Editor.

Deactivate transaction printing

Before you begin

Make sure that the list of [Scheduled jobs] is empty.

Procedure

1. On the operator panel, touch [System] -> [Transaction] -> [Transaction online] to put the printer offline.

The text on the button changes from [On] to [Off].

Note that you can only switch the [Transaction online] function to offline when

- The transaction print jobs are ready.
- The printer contains no more print data.
- The printer has stopped because all the jobs are ready, not because an error has occurred.

When you switch [Transaction online] to offline, the connection to the host is disconnected automatically.

2. Press [Transaction printing mode].

The text on the button changes from [On] to [Off].



NOTE

You can also put the printer offline via the [Transaction printing] section in the Settings Editor.

Activate the MICR mode

Introduction

If your printer contains the optional MICR license, you can use the machine for MICR printing. Then you can print typical transactional documents like checks and other valuable documents. Before you can use the MICR printing functionality, you must first activate the MICR mode in the settings editor. The printer then identifies itself as a MICR printer on your host (in the case of IPDS).

PrintGuard modules

In the MICR mode, the PrintGuard modules are activated automatically. It is not possible to deactivate the PrintGuard modules in this mode. The PrintGuard modules postfuse your prints to improve the quality and durability of the prints.

Before you begin

Make sure that the list of [Scheduled jobs] is empty. Otherwise, you cannot activate transaction printing.

To guarantee the quality of the MICR fonts, make sure that the [Quality enhancement] setting in the Settings Editor ([Transaction printing] - [Setups] - [PCL] or [IPDS] - [Quality enhancement]) is disabled. By factory default, this setting is disabled.

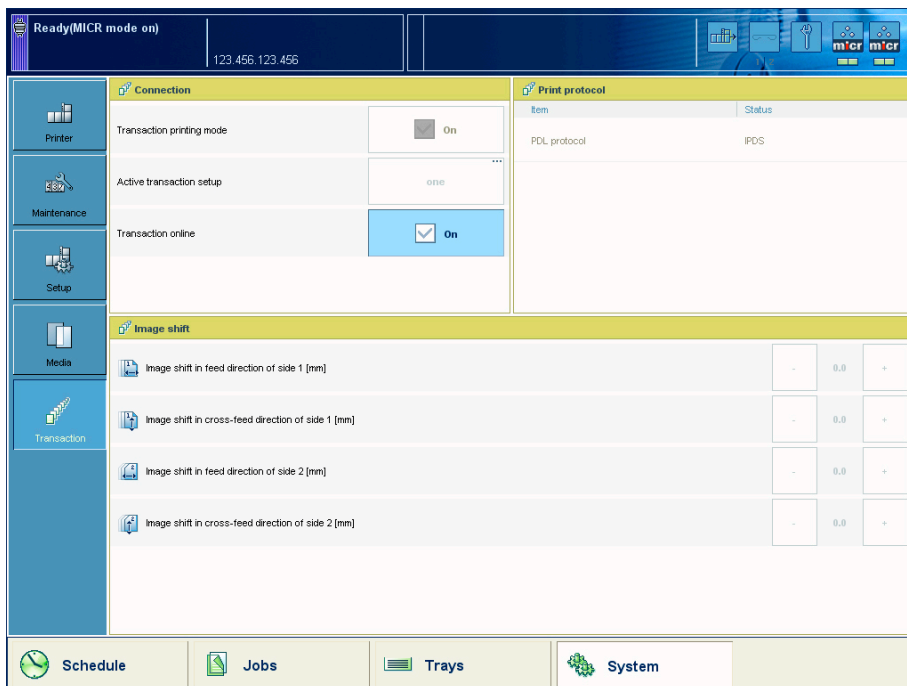

[3] Activated MICR mode

Procedure

1. Create a transaction printing setup (see [Create a transaction setup - How to create a new transaction setup on page 27](#)).
2. In the Settings Editor, go to [Transaction printing] - [Settings].
3. Select [PCL] or [IPDS]

4. Check the [MICR mode (if licensed)] box.

**NOTE**

When you select [IPDS], you can also activate the [Output recovery] setting by putting a check mark in the box (see [Output recovery in case of an error on page 17](#)).

5. Go to [Transaction printing] - [Setups], select the required Setup, then click [Load].
6. On the operator panel, activate the [Transaction printing mode] function in the [System] view (see [Activate transaction printing on page 20](#)).

**NOTE**

You can see that you activated the [MICR mode (if licensed)] on the operator panel in the [System] view - [Transaction] section and in the remote viewer.

Shift the image in the transaction printing mode

Introduction

When a misalignment occurs you can shift the image to correct the problem. You can shift the image on the front side and back side horizontally and vertically. Examples of possible misalignments:

- A name or address is not placed correctly in the right area.
- Lines on the front side and back side of a sheet are not aligned correctly.

To keep the shift settings for future use, you must specify the shift settings in the setup via the Settings Editor. Each time that the setup is loaded, the shift settings included in the setup will become the active shift settings.



NOTE

Only use the image shift function if you want to shift the image of the whole job. The image shift applies to all the media in all the paper trays.

Procedure

1. On the operator panel, touch [System] -> [Transaction].
2. Touch the - or + buttons to shift the image on the front side or back side of the sheet.

Handle the media messages - How to handle the [Media message] in the tray-to-tray mode

Introduction

The media catalog

- contains a list of predefined media and their attributes
- is an essential part of the system behavior of the Océ VarioPrint® 6000 MICR+ line
- helps you to print your jobs more easily while using the correct media

For transaction printing, the content of the paper trays (in terms of media from the media catalog) is translated into a format that the controller understands. However, the controller receives only a limited amount of information (name or size of the media). This can lead to miscommunication where the controller misses a media requirement. The controller will then ask for the required media via a message on the operator panel. This [Media message] indicates the name or size of the missing media.

Your response to the [Media message] depends on the mode in which the printer works, either:

- The tray-to-tray mode, or
- The tray-to-media mode.

This section describes how to respond to the [Media message] for both modes.



NOTE

A [Media message] will only occur when the printer description language is PCL.

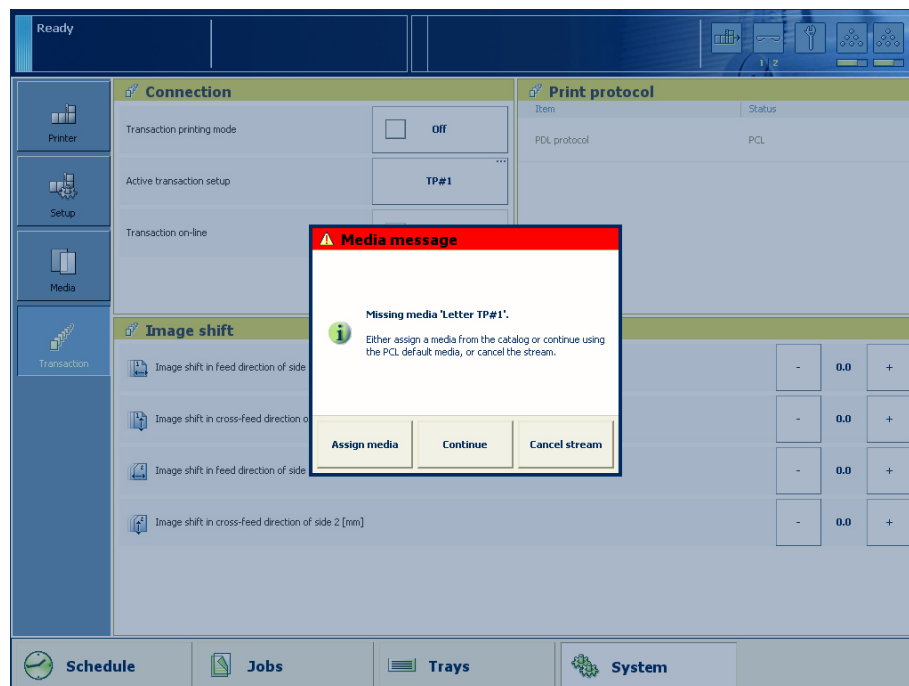

[4] Example of a [Media message]

Procedure

1. A message on the operator panel indicates that a media is missing. Select one of the following actions as a response to the message.
 - Press [Assign media].

Continue with step 2 when you select this option.

- Press [Continue].

The controller will use the PCL default media and continue the print job.

Note that this might be an incorrect media.

- Press [Cancel stream].

The print job is stopped. You can now solve the problem. It is most likely that you can solve the problem on the host.



NOTE

Steps 2 and 3 apply only when you chose to assign a media.

2. From the list of media, select the media that will be used as the media the controller is asking for and press [OK].

Note that this might be an incorrect media.

The media will now be displayed with the name that is defined in the media catalog.

3. Select the paper tray where you want to load the required media and press [OK].
4. Load the media.
5. Close the paper tray.
6. Press [OK].

Now you can assign other media or continue the print job.

Handle the media messages - How to handle the [Media message] in the tray-to-media mode

Procedure

1. A message on the operator panel indicates that a media is missing. Select one of the following actions as a response to the message.
 - Press [Assign media].
Continue with step 2 when you select this option.
 - Press [Continue].
The controller will use the PCL default media and continue the print job.
Note that this might be an incorrect media.
 - Press [Cancel stream].
The print job is stopped. You can now solve the problem. It is most likely that you can solve the problem on the host.



NOTE

The following steps apply only when you chose to assign a media.

2. From the list of media, select the media that will be used as the media the controller is asking for and press [OK].
Note that this might be an incorrect media.
3. Select one of the memory locations of the logical-tray table to be used for the required media.
Note that the media that was previously allocated to that memory position in the setup will be overwritten. Then that media will no longer be available to the transaction stream.
Now you can assign other media or continue the print job.

Create a transaction setup - How to create a new transaction setup

Introduction

When you want to use transaction printing, you have to create the necessary transaction setups. You can create these setups in the Settings Editor.



NOTE

When the Settings Editor does not display the correct language, you can change the preferred language in the Internet options of your Internet browser. The desired language must be first in the list of languages.

Procedure

1. Go to [Transaction Printing] - [Setups] .
2. Click the [Add] button.
A pop-up window appears.
3. Type in the name and the description of the transaction setup.
4. Click [Ok].
5. Place a checkmark in front of the transaction setup to select the setup.
6. Change the settings (see [Create a transaction setup - How to change the IPDS parameters on page 27](#) or [Create a transaction setup - How to change the PCL parameters on page 29](#)).
You can change the settings:
 - by group (click the pencil at the right-hand side of the group settings). This is the preferred method.
 - by item (click the pencil behind the individual settings).



NOTE

The status of the setup is changed to modified. You have to load the setup to make these modifications available on the printer.
Before you can load a transaction setup, you have to switch the transaction printing mode off-line.

7. Go to [Transaction Printing] - [Settings], and click [Toggle the transaction printing mode] to switch the printer off-line.
8. Go to [Transaction Printing] - [Setups], and click [Load].
The setup is now available on your operator panel.

Create a transaction setup - How to change the IPDS parameters

Procedure

1. Go to [Transaction Printing] - [IPDS setup].
2. Make sure that the Tray selection mechanism is set to Tray to Media.
This is the preferred setting. This printer is a media-based machine. The Tray-to-media method supports this behavior.
3. Change the settings under the [IPDS setup] tab.
You can change the settings:
 - by group (click the pencil at the right-hand side of the group settings). This is the preferred method.
 - by item (click the pencil behind the individual settings).

4. For [IPDS Tray to media for media 1] assign the [Media catalog item] from the list. The list displays all the media in the media catalog. The system copies the media attributes from the selected media to the transaction setup.
When you assign A3/Ledger-like media or want to use short-edge feed for other media, change the feed direction to [Short-edge feed (SEF)].



NOTE

The settings editor displays only the media for which the media name is consistent with the IPDS media name definitions. Valid characters for an IPDS media name are: A-Z, a-z, 0-9, blank.

5. Repeat step 4 for all the logical trays in your setup.

Create a transaction setup - How to change the PCL parameters

Procedure

1. Go to [Transaction Printing] - [PCL setup].
2. Make sure that the Tray selection mechanism is set to Tray to Media.
This is the preferred setting. This printer is a media-based machine. The Tray-to-media method supports this behavior.
3. Change the settings under the [PCL setup] tab.
You can change the settings:
 - by group (click the pencil at the right-hand side of the group settings). This is the preferred method.
 - by item (click the pencil behind the individual settings).
4. For [PCL Tray to media for media 1] assign the [Media catalog item] from the list. The list displays all the media in the media catalog.
When you assign A3/Ledger-like media or want to use short-edge feed for other media, change the feed direction to [Short-edge feed (SEF)].
5. Repeat Step 4 for all the logical trays in your setup.

Create a transaction setup - How to modify a transaction setup



NOTE

When you have more than one printer, you can exchange transaction setups. Go to [Transaction Printing] - [Setups] and use the [Import] and [Export] functions.

Procedure

1. Go to [Transaction Printing] - [Setups].
2. Put a checkmark in front of the transaction setup to select the setup you want to modify.
3. Click the [Edit] button, if you want to change the name of the setup.
4. Change the settings under the [IPDS setup] tab (see [Create a transaction setup - How to change the IPDS parameters on page 27](#)).

You can change the settings:

- by group (click the pencil at the right-hand side of the group settings). This is the preferred method.
 - by item (click the pencil behind the individual settings).
5. Change the settings under the [PCL setup] tab (see [Create a transaction setup - How to change the PCL parameters on page 29](#)).
 6. Change the values under the [Settings] tab.



NOTE

The status of the setup is changed to modified. You have to load the setup to make these modification available on the printer.

Before you can load a transaction setup, you have to switch the transaction printing mode off-line.

7. Go to [Transaction Printing] - [Settings], and click [Toggle the transaction printing mode] to switch the printer off-line.
8. Go to back[Transaction Printing] - [Setups].
9. Click [Load].

The setup is now available on your operator panel.

Chapter 3

MICR fonts

MICR fonts

Introduction

Magnetic Ink Character Recognition, or MICR, is a character recognition technology used primarily by the banking industry to facilitate the processing of cheques. The technology allows computers to read information such as account numbers of printed documents. The magnetic reader requires specific MICR fonts. The major MICR fonts used around the world are E-13B and CMC-7.

You can send both outline and bitmap MICR fonts from the host with the datastream of the transaction print job. You can also install outline MICR fonts in the Settings Editor.



NOTE

Do not alter the MICR fonts in any way. Altering the MICR fonts can cause read errors.

Support of MICR fonts

The Océ VarioPrint® 6000 MICR+ line supports all standard MICR fonts with this machine.

Error handling

IPDS

In IPDS, a transaction print job with MICR fonts requires that the machine is in MICR mode. When the machine is not in MICR mode, you will receive an error message on your host that MICR printing is not supported. This error can only be resolved by cancelling the stream.

PCL

In PCL, this is not prevented. The data stream in PCL has no information on the used MICR fonts and therefore, the system does not check whether it is in MICR mode. It is the responsibility of the operator to check this.

Chapter 4

MICR Toner

Check the status of the toner reservoirs







Introduction

The machine has 2 toner reservoirs. The toner reservoirs are located at the left-hand side and the right-hand side of the engine module. You can check the status of the toner reservoirs in the dashboard and in the [System] view. The [System] view also displays the current filling level of each toner reservoir as a percentage. The icons in the following table indicate the status of the toner reservoirs.

This section gives an overview of the possible toner statuses. Furthermore, this section describes how to check the status.

The meaning of the toner icons

The toner icons

Toner icon	Description
	The toner icon is blue. All 2 blocks of the status bar are green. The toner reservoir is filled over 75%. Do not add toner.
	The toner icon is blue. 1 Block of the status bar is green. The toner reservoir is filled over 50%. You can add 1 bottle of toner.
	The toner icon is orange. The status bar contains no more green blocks. The toner reservoir is filled less than 25%. The printer can print another 600 sheets. You must add up to 2 toner bottles as soon as possible.
	The toner icon is red. The status bar has a red frame. The toner reservoir is empty. The printing stops. You must add maximum 2 toner bottles to continue the printing.
	The toner icon is grayed out. The status of the toner reservoir is unknown. This status is only displayed when the system is initializing.
	The toner icon is grayed out and has a blue dotted frame. The status bar is grayed out and has a red dotted frame. The status of the toner reservoir is unknown. This status is only displayed when the toner access cover is open.

Procedure

1. Check the toner icons in the dashboard.



NOTE

Follow the steps 2 and 3 to view the status of the toner reservoirs as a percentage.

2. Touch the [System] button.
3. Press [Printer].

The [System] view displays the current filling level of the toner reservoirs as a percentage. The percentage matches the blocks that are indicated in the dashboard.

Add toner

Introduction

This section describes how to add toner to the 2 toner reservoirs of the machine.

When to do

When a toner reservoir is empty or almost empty.



IMPORTANT

Only use the Océ VarioPrint 6000 MICR toner.



IMPORTANT

Never add more than 2 bottles at a time. The status bars of the toner indicators indicate the amount of bottles you are allowed to fill.



IMPORTANT

The printer must be switched on to add the toner. You can add toner while the printer is busy.

Procedure

1. Shake the toner bottle well (see the instructions on the bottle).
2. Remove the screw cap from the bottle.



IMPORTANT

Do not remove the seal from the bottle.

3. Open the front door of the toner reservoir you want to fill.

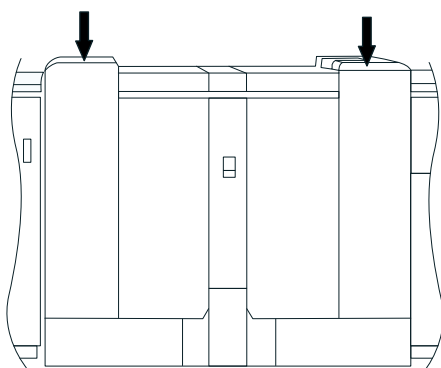

[5] Open the front doors

4. Open the lid of the toner reservoir.
5. Put the toner bottle into the opening of the toner reservoir.



NOTE

The toner bottle only fits one way.

6. When the toner bottle is empty, carefully tilt the toner bottle into the horizontal position. Make sure that the opening of the toner bottle remains over the opening of the toner reservoir.
7. Rotate the toner bottle a half turn to the right to remove the residual toner.
8. Remove the toner bottle.
9. Close the lid of the toner reservoir.
10. Close the front door of the toner reservoir.

Appendix A

Miscellaneous

Product specifications



NOTE

The media specifications in the following table are based on plain paper of 80 g/m² or 20 lb bond.

Overview of the main product specifications

Product specifications

Item	Specification
Technology	Océ Gemini Instant Duplex technology
Print speed (2-sided)	<p>Océ VarioPrint® 6160:</p> <ul style="list-style-type: none"> • 170 images/minute (A4/Letter) • 88 images/minute (A3/Ledger) <p>Océ VarioPrint® 6200:</p> <ul style="list-style-type: none"> • 200 images/minute (A4/Letter) • 106 images/minute (A3/Ledger) <p>Océ VarioPrint® 6250:</p> <ul style="list-style-type: none"> • 250 images/minute (A4/Letter) • 132 images/minute (A3/Ledger)
Supported media sizes	<ul style="list-style-type: none"> • Minimum 8 x 8 inch • Maximum 12.5 x 19.2 inch
Supported media weights	<ul style="list-style-type: none"> • 50 - 300 g/m² for Océ recommended media • 40 - 135 lb. bond for other media
Printable area	<p>Long edge: maximum 19.1 inches</p> <p>Short edge: maximum 12.5 inches</p>
Active registration	< .02 inches
Input capacity per paper module	<ul style="list-style-type: none"> • Normal trays 1 and 2: 600 sheets each • Bulk trays 3 and 4: 1,700 sheets each (or 3,300 A4/Letter sheets each when the optional dual paper trays are installed)
Output capacity per output location	<ul style="list-style-type: none"> • Stacker: 6,000 sheets in 2 stacks of 3,000 sheets each • Finisher: Finisher tray. The finisher tray consist of 3 physical trays. You cannot address these physical trays separately as an output location. <ul style="list-style-type: none"> • Top tray: 900 sheets (A4/Letter) • Middle tray: 1,000 sheets (A4/Letter) • Lower tray: 1,800 sheets (A4/Letter) <p>Upper output: 500 sheets (all sizes)</p>

Item	Specification
Supported media sizes per output location	<ul style="list-style-type: none"> • Stacker: All media sizes between 8 x 8 inch and 12.5 x 19.2 inches • Finisher: Long edge: 10.8 - 12.04 inches Short edge: 8.18 - 8.66 inches
Stapling capacity	<ul style="list-style-type: none"> • Finisher: 100 sheets
Toner	Océ VarioPrint 6000 MICR toner
Resolution	<ul style="list-style-type: none"> • 1200 dpi • 180 lpi
Warm-up time	< 12 minutes
Network connectivity	10/100 Mbit and 1 Gbit Ethernet
Network protocols	<ul style="list-style-type: none"> • TCP/IP • IPX • SMB
Higher level protocols	<ul style="list-style-type: none"> • LPR/LPD for job submission • Socket printing • SNMP
Supported PDLs	<ul style="list-style-type: none"> • Adobe® PostScript® 3™ / streaming PostScript® • PCL 6 (combines PCL5e and PCL XL) • PDF 1.6 • Xerox® PPP support
Supported applications	<ul style="list-style-type: none"> • Océ VarioPrint® 6000 MICR+ line printer driver • Océ PRISMAprepare (5.3.2 and higher) • Océ PRISMAaccess (5.2 and higher) • Océ PRISMAproduction (4.06 and higher) • Océ PRISMAspool 4.04 • Océ PRISMAdrive 2.4 • Océ VPconvert 7 • Xerox® FreeFlow™ MakeReady (7 and higher) • EFI® Fiery Central 1.8.2 • Kodak® Smartboard 5 (limited)
Certification	PIRA
Online finishing (external finisher)	Via DFD2 interface

Index

A

Add toner.....	35
Applications	
Supported.....	39
Available documentation.....	12

C

Capacity	
Output.....	38
Stapling.....	39
Check	
Toner level.....	34
Content of the manuals.....	12
Controller	
Missing media.....	25, 26

D

DFD.....	39
----------	----

E

External finisher.....	39
------------------------	----

F

Features.....	9
Fonts	
Install.....	32
MICR fonts.....	32

I

Image shift	
Transaction printing.....	24
IPDS	
Output recovery.....	17

M

Media message	
General.....	25, 26
Tray-to-media mode.....	26
Tray-to-tray mode.....	25
Media	
Output location.....	38, 39
Supported size.....	38

Supported weight.....	38
MICR Mode.....	22
Activate.....	22
Quality enhancement.....	22

N

Network	
Connectivity.....	39
Protocols.....	39

O

Online finishing.....	39
Output location	
Supported media.....	38, 39
Output recovery.....	17

P

PDL	
Supported.....	39
Print speed.....	38
Printable area.....	38
Product specifications.....	38
Protocols.....	39

R

Registration.....	38
Resolution.....	39

S

SRA controller	
Missing media.....	25
Stapling	
Capacity.....	39
System components	
Engine module.....	10
Operator attention light.....	10
Operator panel.....	10
Paper module.....	10
Printguard modules.....	10
Roll feeder.....	10
Stacker.....	11
System view	
Transaction section.....	14

T

Technology.....38
Toner.....35, 39
Toner icons.....34
Toner indicator
 Status bar.....35
 Toner icon.....35
Trademarks.....3
Transaction printing.....14
 Activate.....20
 Deactivate.....21
 Image shift.....24
 Printer offline.....21
 Printer online.....20
Transaction setups.....27, 29, 30

W

Warm-up time.....39



CANON INC.

www.canon.com

CANON U.S.A., INC.

www.usa.canon.com

CANON CANADA, INC.

www.canon.ca

CANON EUROPA INC.

www.canon-europe.com

CANON LATIN AMERICA INC.

ww.cla.canon.com

CANON AUSTRALIA PTY. LTD

www.canon.com.au

CANON CHINA CO., LTD

www.canon.com.cn

CANON SINGAPORE PTE. LTD.

www.canon.com.sg

CANON HONGKONG CO., LTD

www.canon.com.hk