

Processes



Stick (SMAW) Welding

Description



Engine Driven Welding Generator

CHAMP 1435

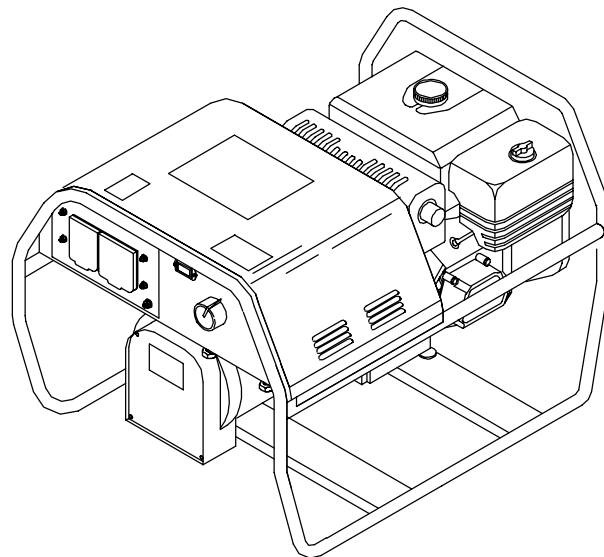

OWNER'S MANUAL

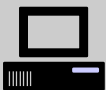

From Hobart to You

Thank you and congratulations on choosing Hobart. Now you can get the job done and get it done right. We know you don't have time to do it any other way.

This Owner's Manual is designed to help you get the most out of your Hobart products. Please take time to read the Safety precautions. They will help you

protect yourself against potential hazards on the worksite. We've made installation and operation quick and easy. With Hobart you can count on years of reliable service with proper maintenance. And if for some reason the unit needs repair, there's a Troubleshooting section that will help you figure out what the problem is. The parts list will then help you to decide which exact part you may need to fix the problem. Warranty and service information for your particular model are also provided.

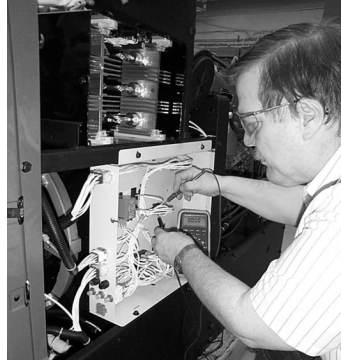

Hobart is registered to the ISO 9001 Quality System Standard.

Hobart Welders manufactures a full line of welders and welding related equipment. For information on other quality Hobart products, contact your local Hobart distributor to receive the latest full line catalog or individual catalog sheets. **To locate your nearest distributor or service agency call 1-877-Hobart1.**



5/3/1 WARRANTY

Working as hard as you do – every power source from Hobart is backed by the best warranty in the business.

Hobart offers a Technical Manual which provides more detailed service and parts information for your unit. To obtain a Technical Manual, contact your local distributor. Your distributor can also supply you with Welding Process Manuals such as SMAW, GTAW, GMAW, and GMAW-P.

HOBART[®]
WELDING PRODUCTS

TABLE OF CONTENTS

WARNING

This product, when used for welding or cutting, produces fumes or gases which contain chemicals known to the State of California to cause birth defects and, in some cases, cancer. (California Health & Safety Code Section 25249.5 et seq.)

WARNING

Battery posts, terminals and related accessories contain lead and lead compounds, chemicals known to the State of California to cause cancer and birth defects or other reproductive harm. Wash hands after handling.

WARNING

The engine exhaust from this product contains chemicals known to the State of California to cause cancer, birth defects, or other reproductive harm.

The following terms are used interchangeably throughout this manual:
TIG = GTAW
Stick = SMAW
MIG = GMAW

| | |
|---|-----------|
| SECTION 1 – SAFETY PRECAUTIONS - READ BEFORE USING | 1 |
| 1-1. Symbol Usage | 1 |
| 1-2. Arc Welding Hazards | 1 |
| 1-3. Engine Hazards | 2 |
| 1-4. Additional Symbols For Installation, Operation, And Maintenance | 3 |
| 1-5. Principal Safety Standards | 4 |
| 1-6. EMF Information | 4 |
| SECTION 1 – CONSIGNES DE SÉCURITÉ – LIRE AVANT UTILISATION | 5 |
| 1-1. Signification des symboles | 5 |
| 1-2. Dangers relatifs au soudage à l'arc | 5 |
| 1-3. Dangers existant en relation avec le moteur | 6 |
| 1-4. Dangers supplémentaires en relation avec l'installation, le fonctionnement et la maintenance | 7 |
| 1-5. Principales normes de sécurité | 8 |
| 1-6. Information sur les champs électromagnétiques | 8 |
| SECTION 2 – DEFINITIONS | 9 |
| SECTION 3 – SPECIFICATIONS | 9 |
| 3-1. Weld, Power, And Engine Specifications | 9 |
| 3-2. Dimensions, Weights, And Operating Angles | 10 |
| 3-3. Fuel Consumption (Kohler-Powered Units) | 10 |
| 3-4. Fuel Consumption (Honda-Powered Units) | 11 |
| 3-5. Duty Cycle | 11 |
| 3-6. Auxiliary Power Curve | 12 |
| 3-7. Volt-Ampere Curves | 12 |
| SECTION 4 – INSTALLATION | 13 |
| 4-1. Installing Welding Generator | 13 |
| 4-2. Grounding Generator To Truck Or Trailer Frame | 13 |
| 4-3. Grounding Generator When Supplying Building Systems | 14 |
| 4-4. Engine Prestart Checks (Kohler-Powered Units) | 14 |
| 4-5. Engine Prestart Checks (Honda-Powered Units) | 15 |
| 4-6. Connecting The Battery (Honda Electric-Start Models Only) | 15 |
| 4-7. Connecting To Weld Output Terminals | 16 |
| 4-8. Selecting Weld Cable Sizes* | 16 |
| SECTION 5 – OPERATING THE WELDING GENERATOR | 17 |
| 5-1. Controls (Kohler-Powered Units) | 17 |
| 5-2. Controls (Honda-Powered Units) (See Section 5-3) | 18 |
| 5-3. Description Of Controls (Honda-Powered Units) (See Section 5-2) | 19 |
| SECTION 6 – OPERATING AUXILIARY EQUIPMENT | 20 |
| 6-1. Auxiliary Power Panel 196 921 (CSA) | 20 |
| 6-2. Optional Auxiliary Power Panels | 21 |
| 6-3. Auxiliary Power Panel Ratings | 22 |
| 6-4. Wiring Instructions For Optional 120/240 Volt Twistlock Plug (NEMA L14-30P) | 23 |
| SECTION 7 – MAINTENANCE | 24 |
| 7-1. Routine Maintenance | 24 |
| 7-2. Maintenance Label | 25 |
| 7-3. Overload Protection (Honda-Powered Units Only) | 25 |
| 7-4. Adjusting Engine Speed (Kohler-Powered Units) | 26 |
| 7-5. Adjusting Engine Speed (Honda-Powered Units) | 27 |
| SECTION 8 – TROUBLESHOOTING | 28 |
| SECTION 9 – ELECTRICAL DIAGRAMS | 30 |
| SECTION 10 – AUXILIARY POWER GUIDELINES | 34 |
| SECTION 11 – STICK WELDING (SMAW) GUIDELINES | 41 |
| SECTION 12 – PARTS LIST | 50 |
| OPTIONS AND ACCESSORIES | |
| WARRANTY | |

SECTION 1 – SAFETY PRECAUTIONS - READ BEFORE USING

rom_nd_11/98

1-1. Symbol Usage



Means Warning! Watch Out! There are possible hazards with this procedure! The possible hazards are shown in the adjoining symbols.

▲ Marks a special safety message.

☞ Means "Note"; not safety related.



This group of symbols means Warning! Watch Out! possible ELECTRIC SHOCK, MOVING PARTS, and HOT PARTS hazards. Consult symbols and related instructions below for necessary actions to avoid the hazards.

1-2. Arc Welding Hazards

▲ The symbols shown below are used throughout this manual to call attention to and identify possible hazards. When you see the symbol, watch out, and follow the related instructions to avoid the hazard. The safety information given below is only a summary of the more complete safety information found in the Safety Standards listed in Section 1-5. Read and follow all Safety Standards.

▲ Only qualified persons should install, operate, maintain, and repair this unit.

▲ During operation, keep everybody, especially children, away.



ELECTRIC SHOCK can kill.

Touching live electrical parts can cause fatal shocks or severe burns. The electrode and work circuit is electrically live whenever the output is on. The input power circuit and machine internal circuits are also live when power is on. In semiautomatic or automatic wire welding, the wire, wire reel, drive roll housing, and all metal parts touching the welding wire are electrically live. Incorrectly installed or improperly grounded equipment is a hazard.

- Do not touch live electrical parts.
- Wear dry, hole-free insulating gloves and body protection.
- Insulate yourself from work and ground using dry insulating mats or covers big enough to prevent any physical contact with the work or ground.
- Do not use AC output in damp areas, if movement is confined, or if there is a danger of falling.
- Use AC output ONLY if required for the welding process.
- If AC output is required, use remote output control if present on unit.
- Disconnect input power or stop engine before installing or servicing this equipment. Lockout/tagout input power according to OSHA 29 CFR 1910.147 (see Safety Standards).
- Properly install and ground this equipment according to its Owner's Manual and national, state, and local codes.
- Always verify the supply ground – check and be sure that input power cord ground wire is properly connected to ground terminal in disconnect box or that cord plug is connected to a properly grounded receptacle outlet.
- When making input connections, attach proper grounding conductor first – double-check connections.
- Frequently inspect input power cord for damage or bare wiring – replace cord immediately if damaged – bare wiring can kill.
- Turn off all equipment when not in use.
- Do not use worn, damaged, undersized, or poorly spliced cables.
- Do not drape cables over your body.
- If earth grounding of the workpiece is required, ground it directly with a separate cable.
- Do not touch electrode if you are in contact with the work, ground, or another electrode from a different machine.
- Use only well-maintained equipment. Repair or replace damaged parts at once. Maintain unit according to manual.

- Wear a safety harness if working above floor level.
- Keep all panels and covers securely in place.
- Clamp work cable with good metal-to-metal contact to workpiece or worktable as near the weld as practical.
- Insulate work clamp when not connected to workpiece to prevent contact with any metal object.
- Do not connect more than one electrode or work cable to any single weld output terminal.

SIGNIFICANT DC VOLTAGE exists after stopping engine on inverters.

- Stop engine on inverter and discharge input capacitors according to instructions in Maintenance Section before touching any parts.

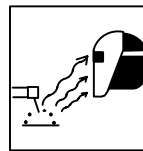

ARC RAYS can burn eyes and skin.

Arc rays from the welding process produce intense visible and invisible (ultraviolet and infrared) rays that can burn eyes and skin. Sparks fly off from the weld.

- Wear a welding helmet fitted with a proper shade of filter to protect your face and eyes from arc rays and sparks when welding or watching (see ANSI Z49.1 and Z87.1 listed in Safety Standards).
- Wear approved safety glasses with side shields under your helmet.
- Use protective screens or barriers to protect others from flash and glare; warn others not to watch the arc.
- Wear protective clothing made from durable, flame-resistant material (wool and leather) and foot protection.

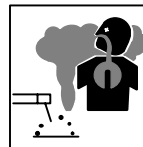

FUMES AND GASES can be hazardous.

Welding produces fumes and gases. Breathing these fumes and gases can be hazardous to your health.

- Keep your head out of the fumes. Do not breathe the fumes.
- If inside, ventilate the area and/or use exhaust at the arc to remove welding fumes and gases.
- If ventilation is poor, use an approved air-supplied respirator.
- Read the Material Safety Data Sheets (MSDSs) and the manufacturer's instructions for metals, consumables, coatings, cleaners, and degreasers.
- Work in a confined space only if it is well ventilated, or while wearing an air-supplied respirator. Always have a trained watch-person nearby. Welding fumes and gases can displace air and lower the oxygen level causing injury or death. Be sure the breathing air is safe.
- Do not weld in locations near degreasing, cleaning, or spraying operations. The heat and rays of the arc can react with vapors to form highly toxic and irritating gases.
- Do not weld on coated metals, such as galvanized, lead, or cadmium plated steel, unless the coating is removed from the weld area, the area is well ventilated, and if necessary, while wearing an air-supplied respirator. The coatings and any metals containing these elements can give off toxic fumes if welded.



WELDING can cause fire or explosion.

Welding on closed containers, such as tanks, drums, or pipes, can cause them to blow up. Sparks can fly off from the welding arc. The flying sparks, hot workpiece, and hot equipment can cause fires and

burns. Accidental contact of electrode to metal objects can cause sparks, explosion, overheating, or fire. Check and be sure the area is safe before doing any welding.

- Protect yourself and others from flying sparks and hot metal.
- Do not weld where flying sparks can strike flammable material.
- Remove all flammables within 35 ft (10.7 m) of the welding arc. If this is not possible, tightly cover them with approved covers.
- Be alert that welding sparks and hot materials from welding can easily go through small cracks and openings to adjacent areas.
- Watch for fire, and keep a fire extinguisher nearby.
- Be aware that welding on a ceiling, floor, bulkhead, or partition can cause fire on the hidden side.
- Do not weld on closed containers such as tanks, drums, or pipes, unless they are properly prepared according to AWS F4.1 (see Safety Standards).
- Connect work cable to the work as close to the welding area as practical to prevent welding current from traveling long, possibly unknown paths and causing electric shock and fire hazards.
- Do not use welder to thaw frozen pipes.
- Remove stick electrode from holder or cut off welding wire at contact tip when not in use.
- Wear oil-free protective garments such as leather gloves, heavy shirt, cuffless trousers, high shoes, and a cap.
- Remove any combustibles, such as a butane lighter or matches, from your person before doing any welding.

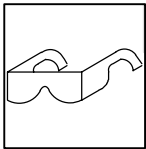

FLYING METAL can injure eyes.

- Welding, chipping, wire brushing, and grinding cause sparks and flying metal. As welds cool, they can throw off slag.
- Wear approved safety glasses with side shields even under your welding helmet.



BUILDUP OF GAS can injure or kill.

- Shut off shielding gas supply when not in use.
- Always ventilate confined spaces or use approved air-supplied respirator.

1-3. Engine Hazards



FUEL can cause fire or explosion.

- Stop engine and let it cool off before checking or adding fuel.
- Do not add fuel while smoking or if unit is near any sparks or open flames.

- Do not overfill tank – allow room for fuel to expand.
- Do not spill fuel. If fuel is spilled, clean up before starting engine.
- Dispose of rags in a fireproof container.



HOT PARTS can cause severe burns.

- Allow cooling period before maintaining.
- Wear protective gloves and clothing when working on a hot engine.
- Do not touch hot engine parts or just-welded parts bare-handed.

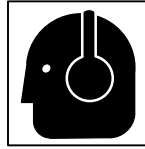

NOISE can damage hearing.

Noise from some processes or equipment can damage hearing.

- Wear approved ear protection if noise level is high.

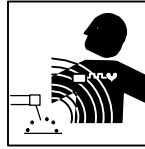

MAGNETIC FIELDS can affect pacemakers.

- Pacemaker wearers keep away.
- Wearers should consult their doctor before going near arc welding, gouging, or spot welding operations.

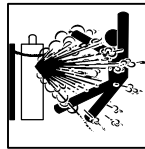

CYLINDERS can explode if damaged.

Shielding gas cylinders contain gas under high pressure. If damaged, a cylinder can explode. Since gas cylinders are normally part of the welding process, be sure to treat them carefully.

- Protect compressed gas cylinders from excessive heat, mechanical shocks, slag, open flames, sparks, and arcs.
- Install cylinders in an upright position by securing to a stationary support or cylinder rack to prevent falling or tipping.
- Keep cylinders away from any welding or other electrical circuits.
- Never drape a welding torch over a gas cylinder.
- Never allow a welding electrode to touch any cylinder.
- Never weld on a pressurized cylinder – explosion will result.
- Use only correct shielding gas cylinders, regulators, hoses, and fittings designed for the specific application; maintain them and associated parts in good condition.
- Turn face away from valve outlet when opening cylinder valve.
- Keep protective cap in place over valve except when cylinder is in use or connected for use.
- Read and follow instructions on compressed gas cylinders, associated equipment, and CGA publication P-1 listed in Safety Standards.

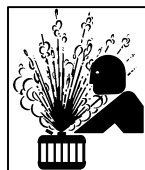

STEAM AND HOT COOLANT can burn.

- If possible, check coolant level when engine is cold to avoid scalding.
- Always check coolant level at overflow tank, if present on unit, instead of radiator (unless told otherwise in maintenance section or engine manual).
- If the engine is warm, checking is needed, and there is no overflow tank, follow the next two statements.
- Wear safety glasses and gloves and put a rag over radiator cap.
- Turn cap slightly and let pressure escape slowly before completely removing cap.



MOVING PARTS can cause injury.

- Keep away from fans, belts, and rotors.
- Keep all doors, panels, covers, and guards closed and securely in place.
- Stop engine before installing or connecting unit.
- Have only qualified people remove guards or covers for maintenance and troubleshooting as necessary.
- To prevent accidental starting during servicing, disconnect negative (-) battery cable from battery.
- Keep hands, hair, loose clothing, and tools away from moving parts.
- Reinstall panels or guards and close doors when servicing is finished and before starting engine.
- Before working on generator, remove spark plugs or injectors to keep engine from kicking back or starting.
- Block flywheel so that it will not turn while working on generator components.



BATTERY EXPLOSION can BLIND.

- Always wear a face shield, rubber gloves, and protective clothing when working on a battery.
- Stop engine before disconnecting or connecting battery cables or servicing battery.
- Do not allow tools to cause sparks when working on a battery.
- Do not use welder to charge batteries or jump start vehicles.
- Observe correct polarity (+ and -) on batteries.
- Disconnect negative (-) cable first and connect it last.

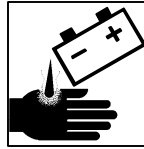

BATTERY ACID can BURN SKIN and EYES.

- Do not tip battery.
- Replace damaged battery.
- Flush eyes and skin immediately with water.

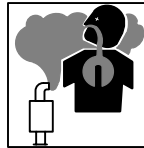

ENGINE EXHAUST GASES can kill.

- Use equipment outside in open, well-ventilated areas.
- If used in a closed area, vent engine exhaust outside and away from any building air intakes.

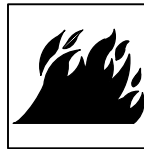

ENGINE HEAT can cause fire.

- Do not locate unit on, over, or near combustible surfaces or flammables.
- Keep exhaust and exhaust pipes way from flammables.



EXHAUST SPARKS can cause fire.

- Do not let engine exhaust sparks cause fire.
- Use approved engine exhaust spark arrestor in required areas – see applicable codes.

1-4. Additional Symbols For Installation, Operation, And Maintenance



FALLING UNIT can cause injury.

- Use lifting eye to lift unit only, NOT running gear, gas cylinders, trailer, or any other accessories.
- Use equipment of adequate capacity to lift and support unit.
- If using lift forks to move unit, be sure forks are long enough to extend beyond opposite side of unit.

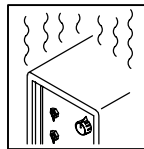

OVERUSE can cause OVERHEATING.

- Allow cooling period; follow rated duty cycle.
- Reduce current or reduce duty cycle before starting to weld again.
- Do not block or filter airflow to unit.

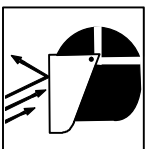

FLYING SPARKS can cause injury.

- Wear a face shield to protect eyes and face.
- Shape tungsten electrode only on grinder with proper guards in a safe location wearing proper face, hand, and body protection.
- Sparks can cause fires — keep flammables away.

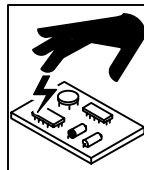

STATIC (ESD) can damage PC boards.

- Put on grounded wrist strap BEFORE handling boards or parts.
- Use proper static-proof bags and boxes to store, move, or ship PC boards.



TILTING OF TRAILER can cause injury.

- Use tongue jack or blocks to support weight.
- Properly install welding generator onto trailer according to instructions supplied with trailer.

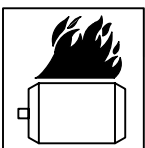

OVERHEATING can damage motors.

- Turn off or unplug equipment before starting or stopping engine.
- Do not let low voltage and frequency caused by low engine speed damage electric motors.
- Do not connect 50 or 60 Hertz motors to the 100 Hertz receptacle where applicable.

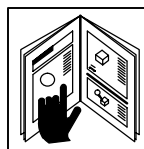

READ INSTRUCTIONS.

- Use only genuine MILLER replacement parts.
- Perform engine maintenance and service according to this manual and the engine manual.

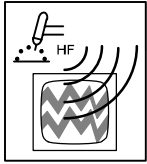

H.F. RADIATION can cause interference.

- High-frequency (H.F.) can interfere with radio navigation, safety services, computers, and communications equipment.
- Have only qualified persons familiar with electronic equipment perform this installation.
- The user is responsible for having a qualified electrician promptly correct any interference problem resulting from the installation.
- If notified by the FCC about interference, stop using the equipment at once.
- Have the installation regularly checked and maintained.
- Keep high-frequency source doors and panels tightly shut, keep spark gaps at correct setting, and use grounding and shielding to minimize the possibility of interference.

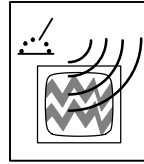

ARC WELDING can cause interference.

- Electromagnetic energy can interfere with sensitive electronic equipment such as computers and computer-driven equipment such as robots.
- Be sure all equipment in the welding area is electromagnetically compatible.
- To reduce possible interference, keep weld cables as short as possible, close together, and down low, such as on the floor.
- Locate welding operation 100 meters from any sensitive electronic equipment.
- Be sure this welding machine is installed and grounded according to this manual.
- If interference still occurs, the user must take extra measures such as moving the welding machine, using shielded cables, using line filters, or shielding the work area.

1-5. Principal Safety Standards

Safety in Welding and Cutting, ANSI Standard Z49.1, from American Welding Society, 550 N.W. LeJeune Rd, Miami FL 33126

Safety and Health Standards, OSHA 29 CFR 1910, from Superintendent of Documents, U.S. Government Printing Office, Washington, D.C. 20402.

Recommended Safe Practices for the Preparation for Welding and Cutting of Containers That Have Held Hazardous Substances, American Welding Society Standard AWS F4.1, from American Welding Society, 550 N.W. LeJeune Rd, Miami, FL 33126

National Electrical Code, NFPA Standard 70, from National Fire Protection Association, Batterymarch Park, Quincy, MA 02269.

Safe Handling of Compressed Gases in Cylinders, CGA Pamphlet P-1, from Compressed Gas Association, 1235 Jefferson Davis Highway, Suite 501, Arlington, VA 22202.

Code for Safety in Welding and Cutting, CSA Standard W117.2, from Canadian Standards Association, Standards Sales, 178 Rexdale Boulevard, Rexdale, Ontario, Canada M9W 1R3.

Safe Practices For Occupation And Educational Eye And Face Protection, ANSI Standard Z87.1, from American National Standards Institute, 1430 Broadway, New York, NY 10018.

Cutting And Welding Processes, NFPA Standard 51B, from National Fire Protection Association, Batterymarch Park, Quincy, MA 02269.

1-6. EMF Information

Considerations About Welding And The Effects Of Low Frequency Electric And Magnetic Fields

Welding current, as it flows through welding cables, will cause electromagnetic fields. There has been and still is some concern about such fields. However, after examining more than 500 studies spanning 17 years of research, a special blue ribbon committee of the National Research Council concluded that: "The body of evidence, in the committee's judgment, has not demonstrated that exposure to power-frequency electric and magnetic fields is a human-health hazard." However, studies are still going forth and evidence continues to be examined. Until the final conclusions of the research are reached, you may wish to minimize your exposure to electromagnetic fields when welding or cutting.

To reduce magnetic fields in the workplace, use the following procedures:

1. Keep cables close together by twisting or taping them.
2. Arrange cables to one side and away from the operator.
3. Do not coil or drape cables around your body.
4. Keep welding power source and cables as far away from operator as practical.
5. Connect work clamp to workpiece as close to the weld as possible.

About Pacemakers:

Pacemaker wearers consult your doctor first. If cleared by your doctor, then following the above procedures is recommended.

SECTION 1 – CONSIGNES DE SÉCURITÉ – LIRE AVANT UTILISATION

rom_nd_fre 11/98

1-1. Signification des symboles



Signifie Mise en garde ! Soyez vigilant ! Cette procédure présente des risques de danger ! Ceux-ci sont identifiés par des symboles adjacents aux directives.

▲ Identifie un message de sécurité particulier.

☞ Signifie NOTA ; n'est pas relatif à la sécurité.



Ce groupe de symboles signifie Mise en garde ! Soyez vigilant ! Il y a des risques de danger reliés aux CHOCS ÉLECTRIQUES, aux PIÈCES EN MOUVEMENT et aux PIÈCES CHAUDES. Reportez-vous aux symboles et aux directives ci-dessous afin de connaître les mesures à prendre pour éviter tout danger.

1-2. Dangers relatifs au soudage à l'arc

▲ Les symboles présentés ci-après sont utilisés tout au long du présent manuel pour attirer votre attention et identifier les risques de danger. Lorsque vous voyez un symbole, soyez vigilant et suivez les directives mentionnées afin d'éviter tout danger. Les consignes de sécurité présentées ci-après ne font que résumer l'information contenue dans les normes de sécurité énumérées à la section 1-5. Veuillez lire et respecter toutes ces normes de sécurité.

▲ L'installation, l'utilisation, l'entretien et les réparations ne doivent être confiés qu'à des personnes qualifiées.

▲ Au cours de l'utilisation, tenir toute personne à l'écart et plus particulièrement les enfants.



UN CHOC ÉLECTRIQUE peut tuer.

Un simple contact avec des pièces électriques peut provoquer une électrocution ou des blessures graves. L'électrode et le circuit de soudage sont sous tension dès que l'appareil est sur ON. Le circuit d'entrée et les circuits internes de l'appareil sont également sous tension à ce moment-là. En soudage semi-automatique ou automatique, le fil, le dévidoir, le logement des galets d'entraînement et les pièces métalliques en contact avec le fil de soudage sont sous tension. Des matériels mal installés ou mal mis à la terre présentent un danger.

- Ne jamais toucher les pièces électriques sous tension.
- Porter des gants et des vêtements de protection secs ne comportant pas de trous.
- S'isoler de la pièce et de la terre au moyen de tapis ou d'autres moyens isolants suffisamment grands pour empêcher le contact physique éventuel avec la pièce ou la terre.
- Ne pas se servir de source électrique à courant électrique dans les zones humides, dans les endroits confinés ou là où on risque de tomber.
- Se servir d'une source électrique à courant électrique UNIQUEMENT si le procédé de soudage le demande.
- Si l'utilisation d'une source électrique à courant électrique s'avère nécessaire, se servir de la fonction de télécommande si l'appareil en est équipé.
- Couper l'alimentation ou arrêter le moteur avant de procéder à l'installation, à la réparation ou à l'entretien de l'appareil. Déverrouiller l'alimentation selon la norme OSHA 29 CFR 1910.147 (voir normes de sécurité).
- Installer et mettre à la terre correctement cet appareil conformément à son manuel d'utilisation et aux codes nationaux, provinciaux et municipaux.
- Toujours vérifier la terre du cordon d'alimentation – Vérifier et s'assurer que le fil de terre du cordon d'alimentation est bien raccordé à la borne de terre du sectionneur ou que la fiche du cordon est raccordée à une prise correctement mise à la terre.
- En effectuant les raccordements d'entrée fixer d'abord le conducteur de mise à la terre approprié et contre-vérifier les connexions.
- Vérifier fréquemment le cordon d'alimentation pour voir s'il n'est pas endommagé ou dénudé – remplacer le cordon immédiatement s'il est endommagé – un câble dénudé peut provoquer une électrocution.
- Mettre l'appareil hors tension quand on ne l'utilise pas.
- Ne pas utiliser des câbles usés, endommagés, de grosseur insuffisante ou mal épissés.
- Ne pas enrouler les câbles autour du corps.
- Si la pièce soudée doit être mise à la terre, la faire directement avec un câble distinct – ne pas utiliser le connecteur de pièce ou le câble de retour.
- Ne pas toucher l'électrode quand on est en contact avec la pièce, la terre ou une électrode provenant d'une autre machine.

- N'utiliser qu'un matériel en bon état. Réparer ou remplacer sur-le-champ les pièces endommagées. Entretenir l'appareil conformément à ce manuel.
- Porter un harnais de sécurité quand on travaille en hauteur.
- Maintenir solidement en place tous les panneaux et capots.
- Fixer le câble de retour de façon à obtenir un bon contact métal-métal avec la pièce à souder ou la table de travail, le plus près possible de la soudure.
- Isoler la pince de masse quand pas mis à la pièce pour éviter le contact avec tout objet métallique.

Une tension DC importante subsiste à l'intérieur des onduleurs après avoir coupé l'alimentation.

- Couper l'alimentation du poste et décharger les condensateurs d'entrée comme indiqué dans la Section Maintenance avant de toucher des composants.

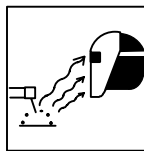

LES RAYONS DE L'ARC peuvent provoquer des brûlures dans les yeux et sur la peau.

Le rayonnement de l'arc du procédé de soudage génère des rayons visibles et invisibles intenses (ultraviolets et infrarouges) susceptibles de provoquer des brûlures dans les yeux et sur la peau. Des étincelles sont projetées pendant le soudage.

- Porter un casque de soudage muni d'un écran de filtre approprié pour protéger votre visage et vos yeux pendant le soudage ou pour regarder (voir ANSI Z49.1 et Z87.1 énuméré dans les normes de sécurité).
- Porter des protections approuvés pour les oreilles si le niveau sonore est trop élevé.
- Utiliser des écrans ou des barrières pour protéger des tiers de l'éclair et de l'éblouissement; demander aux autres personnes de ne pas regarder l'arc.
- Porter des vêtements de protection constitué dans une matière durable, résistant au feu (laine ou cuir) et une protection des pieds.

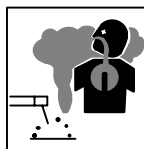

LES FUMÉES ET LES GAZ peuvent être dangereux.

Le soudage génère des fumées et des gaz. Leur inhalation peut être dangereuse pour votre santé.

- Eloigner votre tête des fumées. Ne pas respirer les fumées.
- À l'intérieur, ventiler la zone et/ou utiliser un échappement au niveau de l'arc pour l'évacuation des fumées et des gaz de soudage.
- Si la ventilation est insuffisante, utiliser un respirateur à alimentation d'air homologué.
- Lire les spécifications de sécurité des matériaux (MSDSs) et les instructions du fabricant concernant les métaux, les consommables, les revêtements, les nettoyeurs et les dégraissateurs.
- Travailler dans un espace fermé seulement s'il est bien ventilé ou en portant un respirateur à alimentation d'air. Demander toujours à un surveillant dûment formé de se tenir à proximité. Des fumées et des gaz de soudage peuvent déplacer l'air et abaisser le niveau d'oxygène provoquant des blessures ou des accidents mortels. S'assurer que l'air de respiration ne présente aucun danger.
- Ne pas souder dans des endroits situés à proximité d'opérations de dégraissage, de nettoyage ou de pulvérisation. La chaleur et les rayons de l'arc peuvent réagir en présence de vapeurs et former des gaz hautement toxiques et irritants.
- Ne pas souder des métaux munis d'un revêtement, tels que l'acier galvanisé, plaqué en plomb ou au cadmium à moins que le revêtement n'ait été enlevé dans la zone de soudure, que l'endroit soit bien ventilé, et si nécessaire, en portant un respirateur à alimentation d'air. Les revêtements et tous les métaux renfermant ces éléments peuvent dégager des fumées toxiques en cas de soudage.



LE SOUDAGE peut provoquer un incendie ou une explosion.

Le soudage effectué sur des conteneurs fermés tels que des réservoirs, tambours ou des conduites peut provoquer leur éclatement. Des étincelles peuvent être projetées de l'arc de soudure. La projection d'étincelles, des pièces chaudes et des équipements chauds peut provoquer des incendies et des brûlures. Le contact accidentel de l'électrode avec des objets métalliques peut provoquer des étincelles, une explosion, un surchauffement ou un incendie. Avant de commencer le soudage, vérifier et s'assurer que l'endroit ne présente pas de danger.

- Se protéger et d'autres personnes de la projection d'étincelles et de métal chaud.
- Ne pas souder dans un endroit où des étincelles peuvent tomber sur des substances inflammables.
- Déplacer toutes les substances inflammables à une distance de 10,7 m de l'arc de soudage. En cas d'impossibilité les recouvrir soigneusement avec des protections homologués.
- Des étincelles et des matériaux chauds du soudage peuvent facilement passer dans d'autres zones en traversant de petites fissures et des ouvertures.
- Surveiller tout déclenchement d'incendie et tenir un extincteur à proximité.
- Le soudage effectué sur un plafond, plancher, paroi ou séparation peut déclencher un incendie de l'autre côté.
- Ne pas effectuer le soudage sur des conteneurs fermés tels que des réservoirs, tambours, ou conduites, à moins qu'ils n'aient été préparés correctement conformément à AWS F4.1 (voir les normes de sécurité).
- Brancher le câble sur la pièce le plus près possible de la zone de soudage pour éviter le transport du courant sur une longue distance par des chemins inconnus éventuels en provoquant des risques d'électrocution et d'incendie.
- Ne pas utiliser le poste de soudage pour dégeler des conduites gelées.
- En cas de non utilisation, enlever la bague d'électrode du porte-électrode ou couper le fil à la pointe de contact.
- Porter des vêtements de protection dépourvus d'huile tels que des gants en cuir, une chemise en matériau lourd, des pantalons sans revers, des chaussures hautes et un couvre chef.
- Avant de souder, retirer toute substance combustible de vos poches telles qu'un allumeur au butane ou des allumettes.

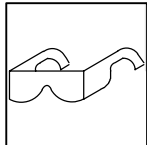

DES PARTICULES VOLANTES peuvent blesser les yeux.

- Le soudage, l'écaillage, le passage de la pièce à la brosse en fil de fer, et le meulage génèrent des étincelles et des particules métalliques volantes.

Pendant la période de refroidissement des soudures, elles risquent de projeter du laitier.

- Porter des lunettes de sécurité avec écrans latéraux ou un écran facial.



LES ACCUMULATIONS DE GAZ risquent de provoquer des blessures ou même la mort.

- Fermer l'alimentation du gaz protecteur en cas de non utilisation.
- Veiller toujours à bien aérer les espaces confinés ou se servir d'un respirateur d'adduction d'air homogué.



DES PIÈCES CHAUDES peuvent provoquer des brûlures graves.

- Prévoir une période de refroidissement avant d'effectuer des travaux d'entretien.
- Porter des gants et des vêtements de protection pour travailler sur un moteur chaud.
- Ne pas toucher à mains nues les parties chaudes du moteur ni les pièces récemment soudées.

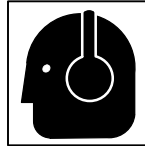

LE BRUIT peut affecter l'ouïe.

Le bruit des processus et des équipements peut affecter l'ouïe.

- Porter des protections approuvés pour les oreilles si le niveau sonore est trop élevé.

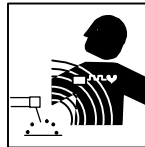

LES CHAMPS MAGNÉTIQUES peuvent affecter les stimulateurs cardiaques.

- Porteurs de stimulateur cardiaque, restez à distance.
- Les porteurs d'un stimulateur cardiaque doivent d'abord consulter leur médecin avant de s'approcher des opérations de soudage à l'arc, de gougeage ou de soudage par points.

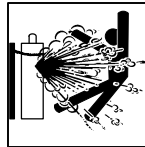

Si des BOUTEILLES sont endommagées, elles pourront exploser.

Des bouteilles de gaz protecteur contiennent du gaz sous haute pression. Si une bouteille est endommagée, elle peut exploser. Du fait que les bouteilles de gaz font normalement partie du procédé de soudage, les manipuler avec précaution.

- Protéger les bouteilles de gaz comprimé d'une chaleur excessive, des chocs mécaniques, du laitier, des flammes ouvertes, des étincelles et des arcs.
- Placer les bouteilles debout en les fixant dans un support stationnaire ou dans un porte-bouteilles pour les empêcher de tomber ou de se renverser.
- Tenir les bouteilles éloignées des circuits de soudage ou autres circuits électriques.
- Ne jamais placer une torche de soudage sur une bouteille à gaz.
- Une électrode de soudage ne doit jamais entrer en contact avec une bouteille.
- Ne jamais souder une bouteille pressurisée – risque d'explosion.
- Utiliser seulement des bouteilles de gaz protecteur, régulateurs, tuyaux et raccords convenables pour cette application spécifique; les maintenir ainsi que les éléments associés en bon état.
- Ne pas tenir la tête en face de la sortie en ouvrant la soupape de la bouteille.
- Maintenir le chapeau de protection sur la soupape, sauf en cas d'utilisation ou de branchement de la bouteille.
- Lire et suivre les instructions concernant les bouteilles de gaz comprimé, les équipements associés et les publication P-1 CGA énumérées dans les normes de sécurité.

1-3. Dangers existant en relation avec le moteur



LE CARBURANT MOTEUR peut provoquer un incendie ou une explosion.

- Arrêter le moteur avant de vérifier le niveau de carburant ou de faire le plein.
- Ne pas faire le plein en fumant ou proche d'une source d'étincelles ou d'une flamme nue.
- Ne pas faire le plein de carburant à ras bord; prévoir de l'espace pour son expansion.
- Faire attention de ne pas renverser de carburant. Nettoyer tout carburant renversé avant de faire démarrer le moteur.
- Jeter les chiffons dans un récipient ignifuge.

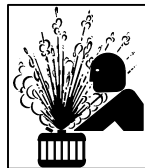

LA VAPEUR ET LE LIQUIDE DE REFROIDISSEMENT CHAUD peuvent provoquer des brûlures.

- Il est préférable de vérifier le liquide de refroidissement une fois le moteur refroidi pour éviter de se brûler.
- Toujours vérifier le niveau de liquide de refroidissement dans le vase d'expansion (si présent), et non dans le radiateur (sauf si précisé autrement dans la section maintenance du manuel du moteur).
- Si le moteur est chaud et que le liquide doit être vérifié, opérer comme suivant :
- Mettre des lunettes de sécurité et des gants, placer un torchon sur le bouchon du radiateur.
- Dévisser le bouchon légèrement et laisser la vapeur s'échapper avant d'enlever le bouchon.



DES ORGANES MOBILES peuvent provoquer des blessures.

- Ne pas approcher les mains des ventilateurs, courroies et autres pièces en mouvement.
- Maintenir fermés et fixement en place les portes, panneaux, recouvrements et dispositifs de protection.
- Arrêter le moteur avant d'installer ou brancher l'appareil.
- Demander seulement à un personnel qualifié d'enlever les dispositifs de sécurité ou les recouvrements pour effectuer, s'il y a lieu, des travaux d'entretien et de dépannage.
- Pour empêcher tout démarrage accidentel pendant les travaux d'entretien, débrancher le câble négatif (-) de batterie de la borne.
- Ne pas approcher les mains, cheveux, vêtements lâches et outils des organes mobiles.
- Remettre en place les panneaux ou les dispositifs de protection et fermer les portes à la fin des travaux d'entretien et avant de faire démarrer le moteur.
- Avant d'intervenir, déposer les bougies ou injecteurs pour éviter la mise en route accidentelle du moteur.
- Bloquer le volant moteur pour éviter sa rotation lors d'une intervention sur le générateur.

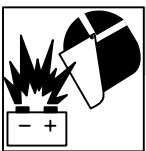

L'EXPLOSION DE LA BATTERIE peut RENDRE AVEUGLE.

- Toujours porter une protection faciale, des gants en caoutchouc et vêtements de protection lors d'une intervention sur la batterie.
- Arrêter le moteur avant de débrancher ou de brancher les câbles de batterie.
- Eviter de provoquer des étincelles avec les outils en travaillant sur la batterie.
- Ne pas utiliser le poste de soudage pour charger les batteries ou des véhicules de démarrage rapide.
- Observer la polarité correcte (+ et -) sur les batteries.
- Débrancher le câble négatif (-) en premier lieu. Le rebrancher en dernier lieu.

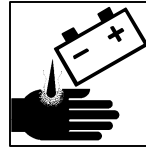

L'ACIDE DE LA BATTERIE peut provoquer des brûlures dans les YEUX et sur la PEAU.

- Ne pas renverser la batterie.
- Remplacer une batterie endommagée.
- Rincer immédiatement les yeux et la peau à l'eau.

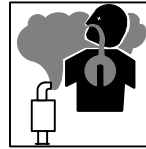

LES GAZ D'ÉCHAPPEMENT DU MOTEUR peuvent provoquer des accidents mortels.

- Utiliser l'équipement à l'extérieur dans des zones ouvertes et bien ventilées.
- En cas d'utilisation dans un endroit fermé évacuer les gaz d'échappement du moteur vers l'extérieur à distance des entrées d'air dans les bâtiments.

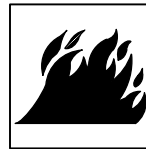

LA CHALEUR DU MOTEUR peut provoquer un incendie.

- Ne pas placer l'appareil sur, au-dessus ou à proximité de surfaces inflammables.
- Tenir à distance les produits inflammables de l'échappement.



LES ÉTINCELLES À L'ÉCHAPPEMENT peuvent provoquer un incendie.

- Empêcher les étincelles d'échappement du moteur de provoquer un incendie.
- Utiliser uniquement un pare-étincelles approuvé – voir codes en vigueur.

1-4. Dangers supplémentaires en relation avec l'installation, le fonctionnement et la maintenance



LA CHUTE DE L'APPAREIL peut blesser.

- Utiliser l'anneau de levage uniquement pour soulever l'appareil lui-même ; sans chariot, de bouteilles de gaz, remorque, ou autres accessoires.
- Utiliser un équipement de levage de capacité suffisante pour lever l'appareil.
- En utilisant des fourches de levage pour déplacer l'unité, s'assurer que les fourches sont suffisamment longues pour dépasser du côté opposé de l'appareil.

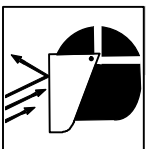

LES ÉTINCELLES VOLANTES risquent de provoquer des blessures.

- Porter un écran facial pour protéger le visage et les yeux.
- Affûter l'électrode au tungstène uniquement à la meuleuse dotée de protecteurs. Cette manoeuvre est à exécuter dans un endroit sûr lorsque l'on porte l'équipement homologué de protection du visage, des mains et du corps.
- Les étincelles risquent de causer un incendie – éloigner toute substance inflammable.

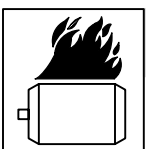

LE SURCHAUFFEMENT peut endommager le moteur électrique.

- Arrêter ou déconnecter l'équipement avant de démarrer ou d'arrêter le moteur.
- Ne pas laisser tourner le moteur trop lentement sous risque d'endommager le moteur électrique à cause d'une tension et d'une fréquence trop faibles.
- Ne pas brancher de moteur de 50 ou de 60 Hz à la prise de 100 Hz, s'il y a lieu.

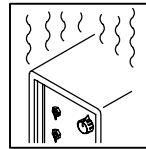

L'EMPLOI EXCESSIF peut SURCHAUFFER L'ÉQUIPEMENT.

- Laisser l'équipement refroidir ; respecter le facteur de marche nominal.
- Réduire le courant ou le facteur de marche avant de poursuivre le soudage.
- Ne pas obstruer les passages d'air du poste.

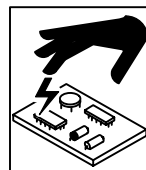

LES CHARGES ÉLECTROSTATIQUES peuvent endommager les circuits imprimés.

- Établir la connexion avec la barrette de terre avant de manipuler des cartes ou des pièces.
- Utiliser des pochettes et des boîtes antistatiques pour stocker, déplacer ou expédier des cartes de circuits imprimés.

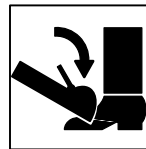

UNE REMORQUE QUI BASCULE peut entraîner des blessures.

- Utiliser les supports de la remorque ou des blocs pour soutenir le poids.
- Installer convenablement le poste sur la remorque comme indiqué dans le manuel s'y rapportant.

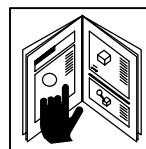

LIRE LES INSTRUCTIONS.

- Utiliser seulement les pièces de rechange d'origine.
- Effectuer la maintenance et la mise en service d'après le manuel et celui du moteur.

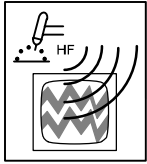

LE RAYONNEMENT HAUTE FRÉQUENCE (H.F.) risque de provoquer des interférences.

- Le rayonnement haute fréquence (H.F.) peut provoquer des interférences avec les équipements de radio-navigation et de communication, les services de sécurité et les ordinateurs.
- Demander seulement à des personnes qualifiées familiarisées avec des équipements électroniques de faire fonctionner l'installation.
- L'utilisateur est tenu de faire corriger rapidement par un électricien qualifié les interférences résultant de l'installation.
- Si le FCC signale des interférences, arrêter immédiatement l'appareil.
- Effectuer régulièrement le contrôle et l'entretien de l'installation.
- Maintenir soigneusement fermés les portes et les panneaux des sources de haute fréquence, maintenir les éclateurs à une distance correcte et utiliser une terre et un blindage pour réduire les interférences éventuelles.

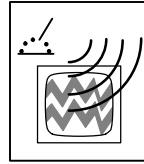

LE SOUDAGE À L'ARC risque de provoquer des interférences.

- L'énergie électromagnétique risque de provoquer des interférences pour l'équipement électronique sensible tel que les ordinateurs et l'équipement commandé par ordinateur tel que les robots.
- Veiller à ce que tout l'équipement de la zone de soudage soit compatible électromagnétiquement.
- Pour réduire la possibilité d'interférence, maintenir les câbles de soudage aussi courts que possible, les grouper, et les poser aussi bas que possible (ex. par terre).
- Veiller à souder à une distance de 100 mètres de tout équipement électronique sensible.
- Veiller à ce que ce poste de soudage soit posé et mis à la terre conformément à ce mode d'emploi.
- En cas d'interférences après avoir pris les mesures précédentes, il incombe à l'utilisateur de prendre des mesures supplémentaires telles que le déplacement du poste, l'utilisation de câbles blindés, l'utilisation de filtres de ligne ou la pose de protecteurs dans la zone de travail.

1-5. Principales normes de sécurité

Safety in Welding and Cutting, norme ANSI Z49.1, de l'American Welding Society, 550 N.W. Lejeune Rd, Miami FL 33126

Safety and Health Standards, OSHA 29 CFR 1910, du Superintendent of Documents, U.S. Government Printing Office, Washington, D.C. 20402.

Recommended Safe Practice for the Preparation for Welding and Cutting of Containers That Have Held Hazardous Substances, norme AWS F4.1, de l'American Welding Society, 550 N.W. Lejeune Rd, Miami FL 33126

National Electrical Code, NFPA Standard 70, de la National Fire Protection Association, Batterymarch Park, Quincy, MA 02269.

Safe Handling of Compressed Gases in Cylinders, CGA Pamphlet P-1, de la Compressed Gas Association, 1235 Jefferson Davis Highway, Suite 501, Arlington, VA 22202.

Règles de sécurité en soudage, coupage et procédés connexes, norme CSA W117.2, de l'Association canadienne de normalisation, vente de normes, 178 Rexdale Boulevard, Rexdale (Ontario) Canada M9W 1R3.

Safe Practices For Occupation And Educational Eye And Face Protection, norme ANSI Z87.1, de l'American National Standards Institute, 1430 Broadway, New York, NY 10018.

Cutting and Welding Processes, norme NFPA 51B, de la National Fire Protection Association, Batterymarch Park, Quincy, MA 02269.

1-6. Information sur les champs électromagnétiques

Données sur le soudage électrique et sur les effets, pour l'organisme, des champs magnétiques basse fréquence

Le courant de soudage, pendant son passage dans les câbles de soudage, causera des champs électromagnétiques. Il y a eu et il y a encore un certain souci à propos de tels champs. Cependant, après avoir examiné plus de 500 études qui ont été faites pendant une période de recherche de 17 ans, un comité spécial ruban bleu du National Research Council a conclu: "L'accumulation de preuves, suivant le jugement du comité, n'a pas démontré que l'exposition aux champs magnétiques et champs électriques à haute fréquence représente un risque à la santé humaine". Toutefois, des études sont toujours en cours et les preuves continuent à être examinées. En attendant que les conclusions finales de la recherche soient établies, il vous serait souhaitable de réduire votre exposition aux champs électromagnétiques pendant le soudage ou le coupage.

Afin de réduire les champs électromagnétiques dans l'environnement de travail, respecter les consignes suivantes :













- 1 Garder les câbles ensemble en les torsadant ou en les attachant avec du ruban adhésif.
- 2 Mettre tous les câbles du côté opposé de l'opérateur.
- 3 Ne pas courber pas et ne pas entourer pas les câbles autour de votre corps.
- 4 Garder le poste de soudage et les câbles le plus loin possible de vous.
- 5 Relier la pince de masse le plus près possible de la zone de soudure.

Consignes relatives aux stimulateurs cardiaques :

Les personnes qui portent un stimulateur cardiaque doivent avant tout consulter leur docteur. Si vous êtes déclaré apte par votre docteur, il est alors recommandé de respecter les consignes ci-dessus.

SECTION 2 – DEFINITIONS

2-1. Symbol Definitions

| | | | | | | | |
|---|-----------------|---|------------------------|---|--------------------------|---|---------------------------|
|  | Engine Choke |  | Read Operator's Manual | A | Amperes | V | Volts |
|  | Engine Oil |  | Fuel |  | Battery (Engine) |  | Engine |
| + | Positive | — | Negative |  | Alternating Current (AC) |  | Output |
| h | Hours | s | Seconds |  | Time |  | Protective Earth (Ground) |
|  | Circuit Breaker |  | Temperature | | | | |

SECTION 3 – SPECIFICATIONS

NOTE

This unit uses either a Kohler or a Honda engine. Differences between models are noted throughout this manual.

3-1. Weld, Power, And Engine Specifications

| Welding Mode | Weld Output Range | Rated Welding Output | Maximum Open Circuit Voltage | Auxiliary Power Rating | Fuel Capacity | Engine |
|--------------|-------------------|---|------------------------------|---|---|---|
| CC/DC | 40 – 140 A | 140 A, 25 V, 30% Duty Cycle 100 A, 25 V, 60% Duty Cycle 80 A, 25 V 100% Duty Cycle | 70 | Single-Phase, 3.5 kVA/kW 30/15 A, 120/240 V AC, 60 Hz | Kohler: 1.8 gal (6.9 L) Tank Honda: 1.6 gal (6 L) Tank | Kohler CS8.5TG Air-Cooled, One-Cylinder, Four-Cycle, 8.5 HP (300 CC), Gasoline Engine OR Honda GX270 Air-Cooled, One-Cylinder, Four-Cycle, 9 HP (270 CC), Gasoline Engine |

3-2. Dimensions, Weights, And Operating Angles

| Dimensions | |
|---------------------------------------|-----------------------|
| Height | 20-3/4 in (527 mm) |
| Width | 22-3/4 in (577 mm) |
| Depth | 31-1/4 in (793 mm) |
| A | 31-1/4 in (793 mm) |
| B | 10-1/2 in (268 mm) |
| C | 13-45/64 in (348 mm) |
| D | 22-3/4 in (577 mm) |
| E | 1-3/4 in (44 mm) |
| F | 19-1/2 in (495 mm) |
| G | 13/32 in (10 mm) Dia. |
| Weight (Kohler-Powered Units) | |
| 222 lb (101 kg) | |
| Weight (Honda-Powered Units) | |
| Electric-Start Model: 226 lb (103 kg) | |
| Recoil-Start Model: 201 lb (91 kg) | |

▲ Do not exceed tilt angles or engine could be damaged or unit could tip.

▲ Do not move or operate unit where it could tip.

3-3. Fuel Consumption (Kohler-Powered Units)

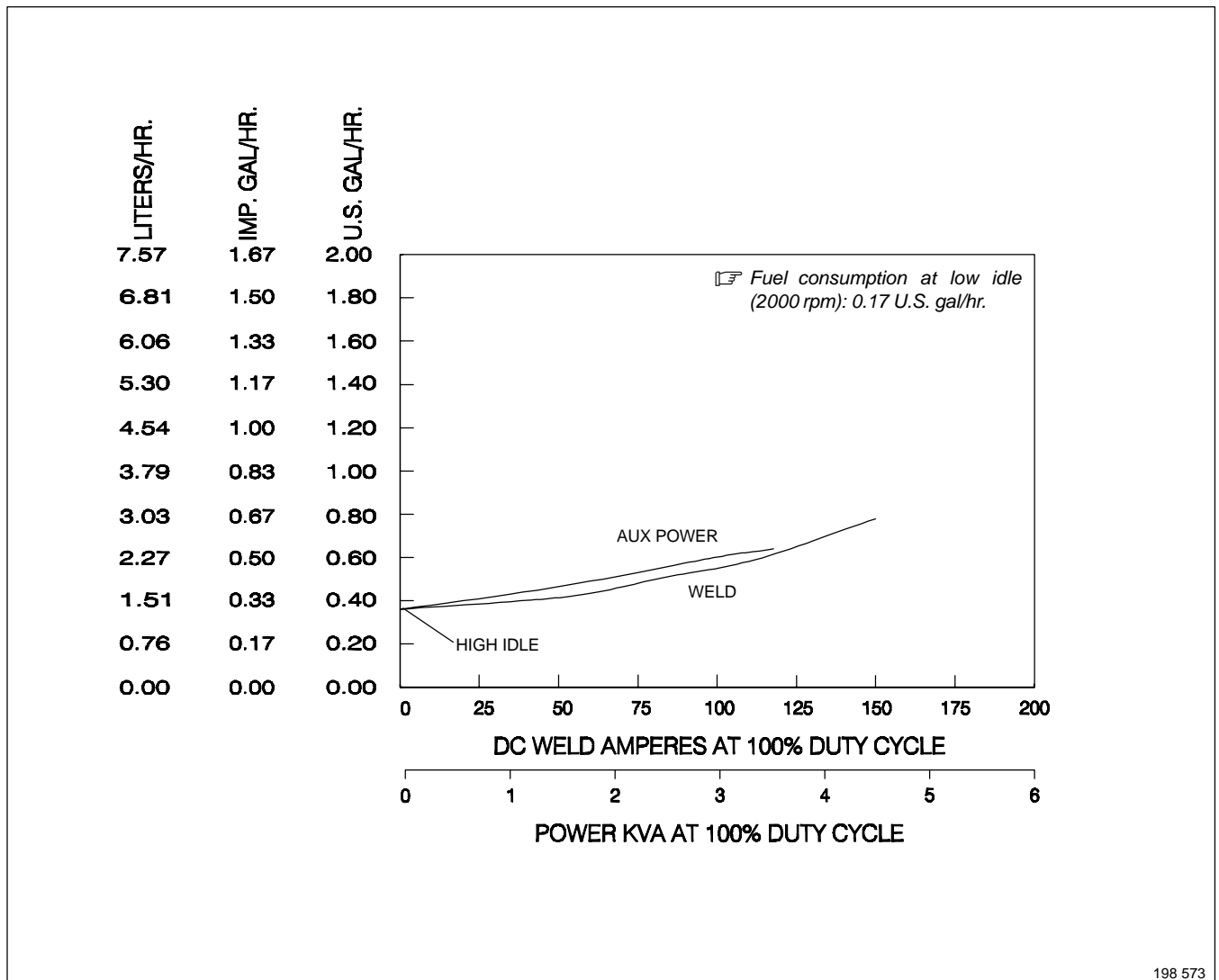

3-4. Fuel Consumption (Honda-Powered Units)

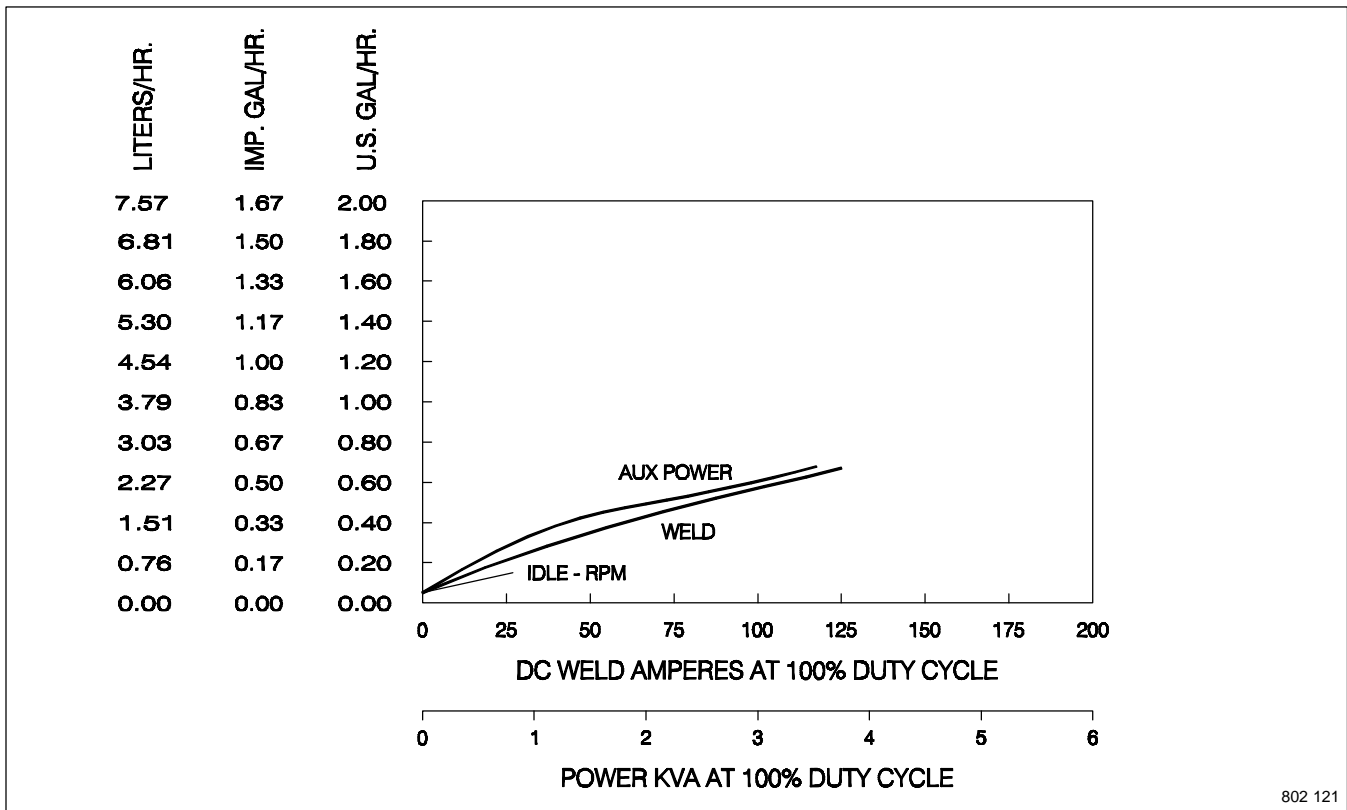

3-5. Duty Cycle

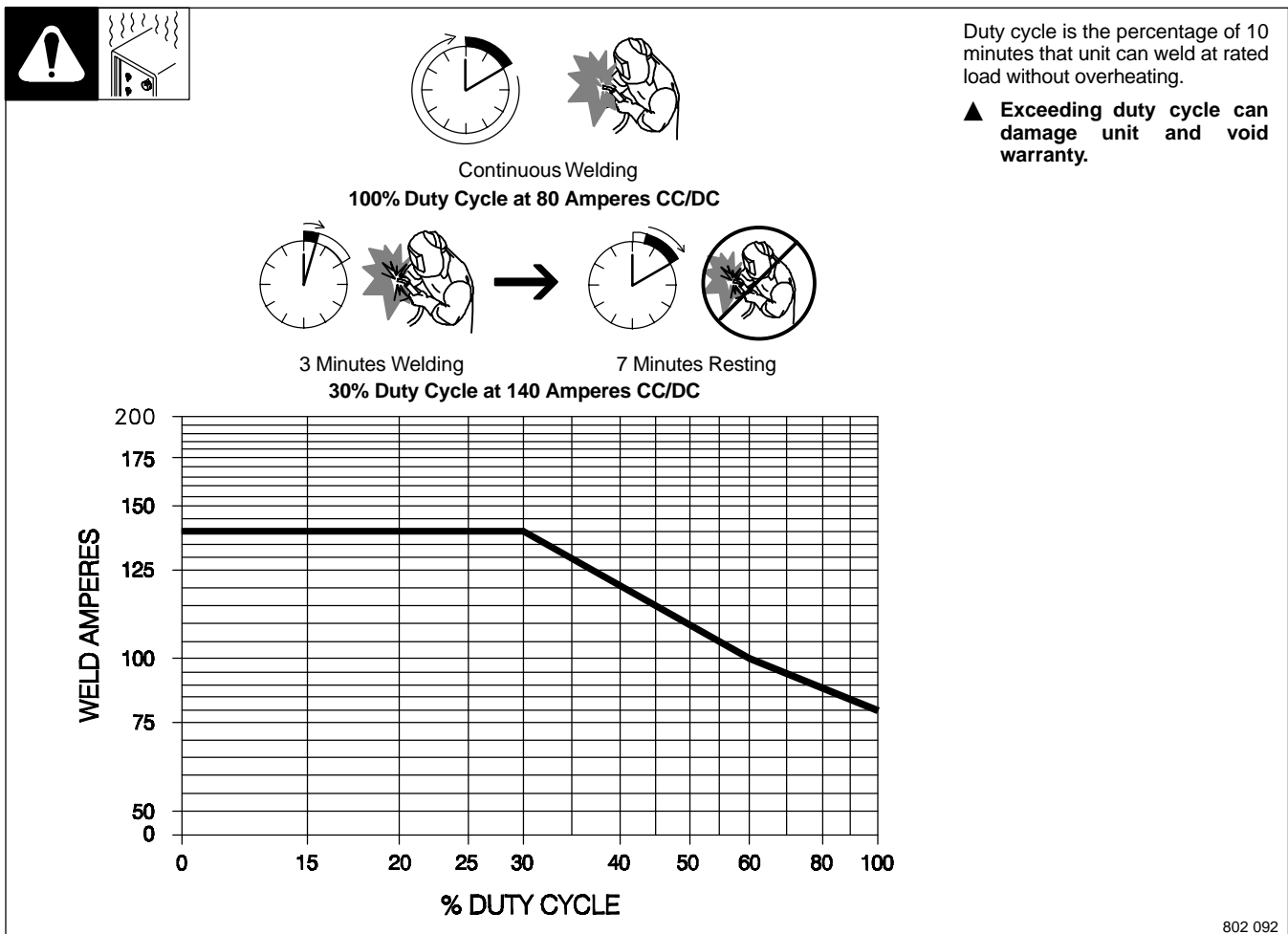

3-6. Auxiliary Power Curve

The ac auxiliary power curves show the auxiliary power available in amperes at the receptacles.

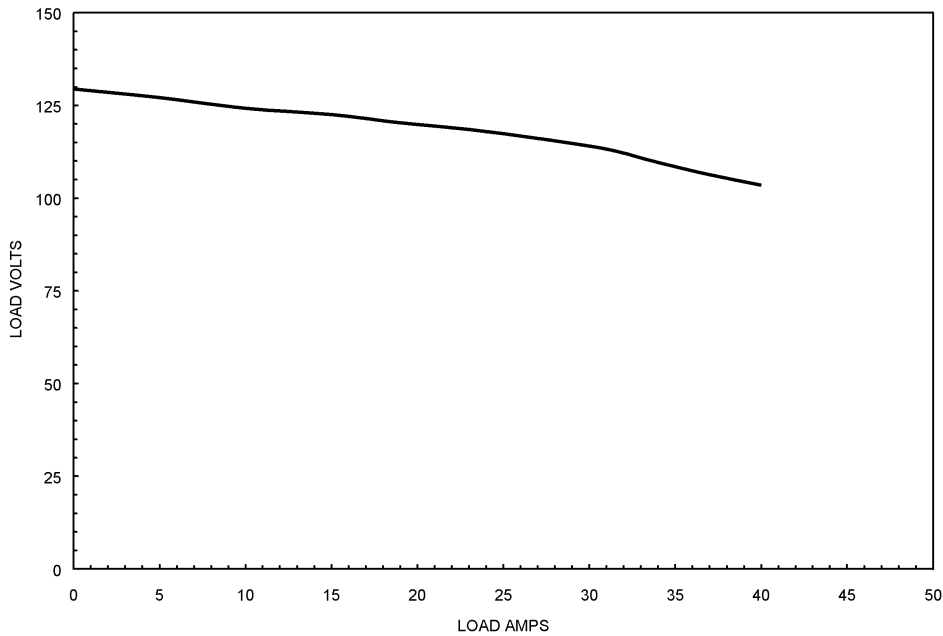

802 129

3-7. Volt-Ampere Curves

The volt-ampere curve shows the minimum and maximum voltage and amperage output capabilities of the welding generator. Curves of all other settings fall between the curves shown.

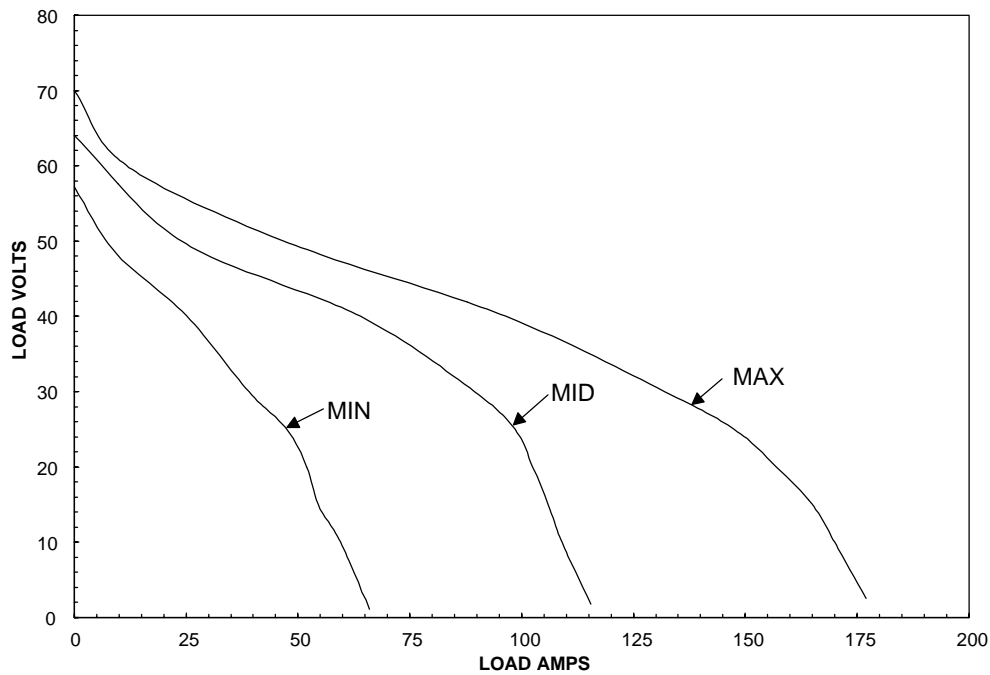

198 453

SECTION 4 – INSTALLATION

4-1. Installing Welding Generator



Movement

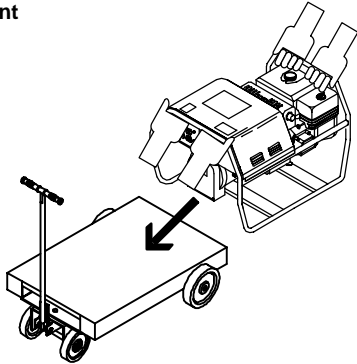

Airflow Clearance

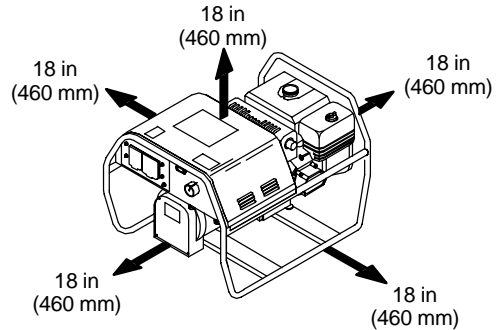

Location

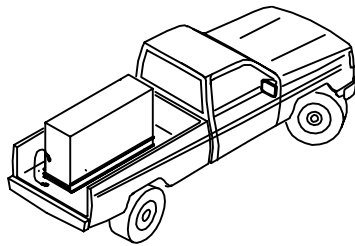

OR

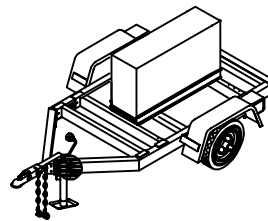

install1 1/97 – 802 512-A / Ref. 151 556 / 158 936-A / S-0854

4-2. Grounding Generator To Truck Or Trailer Frame

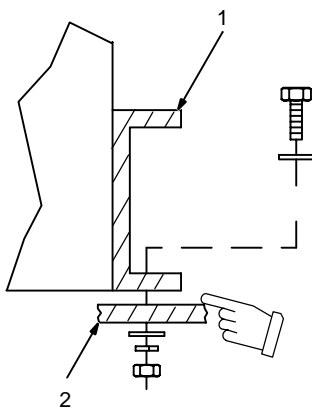

OR

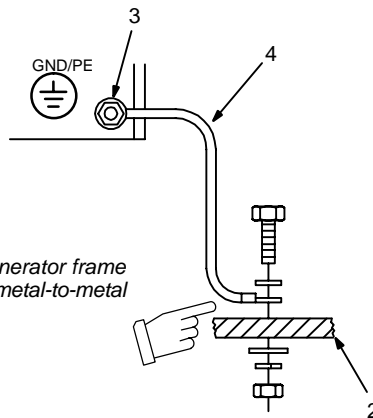

Electrically bond generator frame to vehicle frame by metal-to-metal contact.

▲ **Always ground generator frame to vehicle frame to prevent electric shock and static electricity hazards.**



- 1 Generator Base
- 2 Metal Vehicle Frame
- 3 Equipment Grounding Terminal
- 4 Grounding Cable

Use #10 AWG or larger insulated copper wire.

▲ **If unit does not have GFCI receptacles, use GFCI-protected extension cord.**

install1 1/97* – Ref. 151 556 / S-0854

4-3. Grounding Generator When Supplying Building Systems

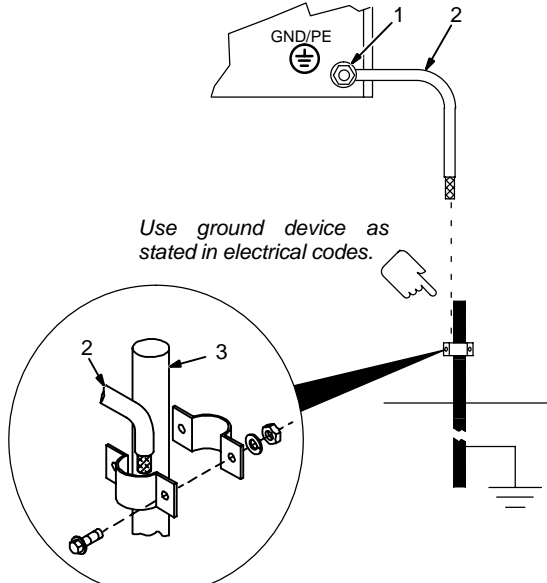

Use ground device as stated in electrical codes.

- 1 Equipment Grounding Terminal
- 2 Grounding Cable



Use #10 AWG or larger insulated copper wire.

- 3 Ground Device

▲ **Ground generator to system earth ground if supplying power to a premises (home, shop, farm) wiring system.**

800 576-B

4-4. Engine Prestart Checks (Kohler-Powered Units)

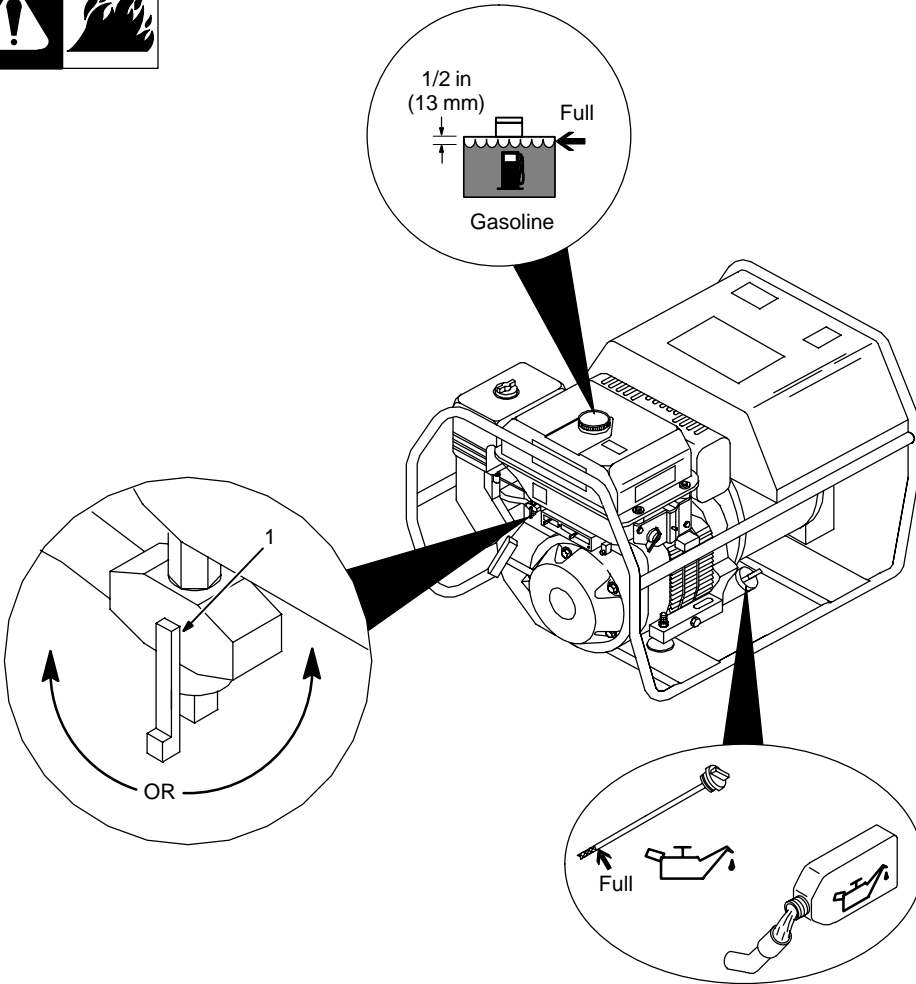

1/2 in (13 mm) Full

Gasoline

OR

Full

☞ Follow run-in procedure in engine manual.

Check all fluids daily. Engine must be cold and on a level surface. Unit is shipped with 10W30 engine oil.

Engine stops if oil level gets too low.

☞ This unit has a low oil level shutdown switch. However, some conditions may cause engine damage before the engine shuts down. Check oil level often and do not use the oil level shutdown system to monitor oil level.

- 1 Fuel Valve

Open valve.

☞ Close fuel valve before moving unit or carburetor may flood and make starting difficult.

Fuel

Add fresh fuel before starting engine the first time (see maintenance label for specifications). Fill fuel tank up to 1/2 in. (13 mm) from top to allow room for expansion. Check fuel level on a cold engine before use each day.

Oil

After fueling, check oil with unit on level surface. If oil is not up to full mark on dipstick, add oil (see maintenance label).

☞ To improve cold weather starting:

Keep battery in good condition. Store battery in warm area off concrete surface.

Use correct grade oil for cold weather.

Ref. 802 512-A

4-5. Engine Prestart Checks (Honda-Powered Units)

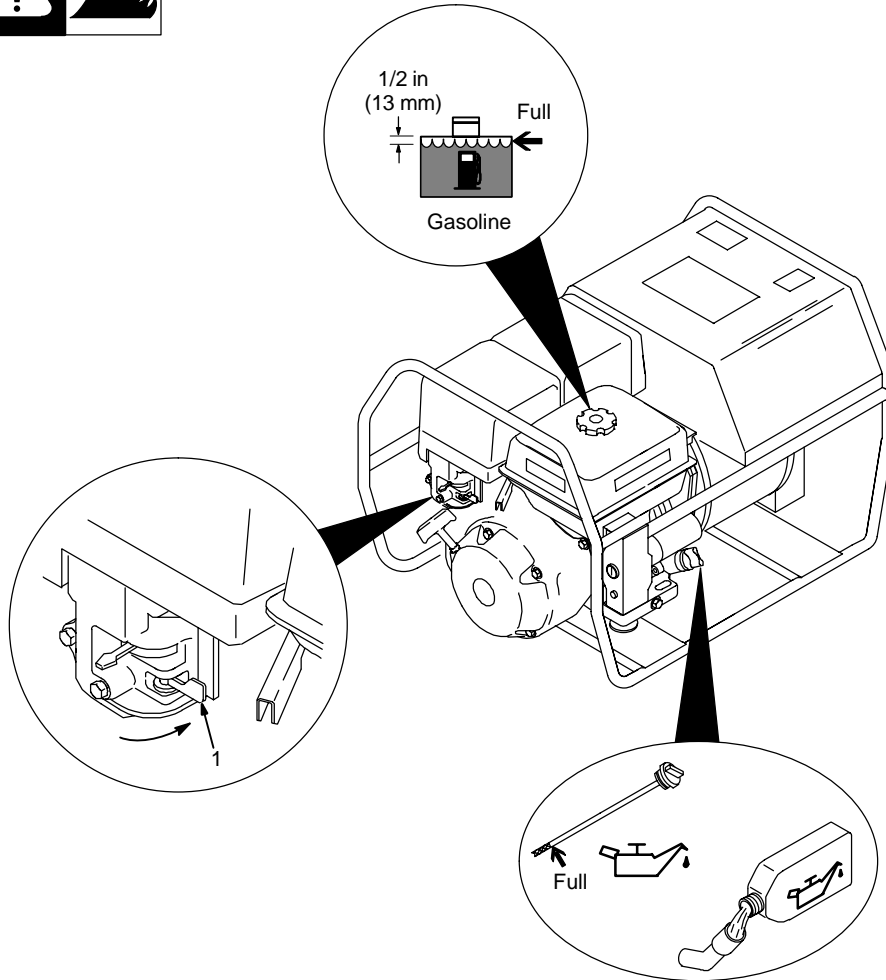

Check all fluids daily. Engine must be cold and on a level surface. Unit is shipped with 10W30 engine oil.

Engine stops if oil level gets too low.

- 1 Fuel Valve
Open valve.

Close fuel valve before moving unit or carburetor may flood and make starting difficult.

Fuel

Add fresh fuel before starting engine the first time (see maintenance label for specifications). Fill fuel tank up to 1/2 in. (13 mm) from top to allow room for expansion. Check fuel level on a cold engine before use each day.

Oil

After fueling, check oil with unit on level surface. If oil is not up to full mark on dipstick, add oil (see maintenance label).

To improve cold weather starting:

Keep battery in good condition. Store battery in warm area off concrete surface.

Use correct grade oil for cold weather.

Ref. 802 099-A

4-6. Connecting The Battery (Honda Electric-Start Models Only)

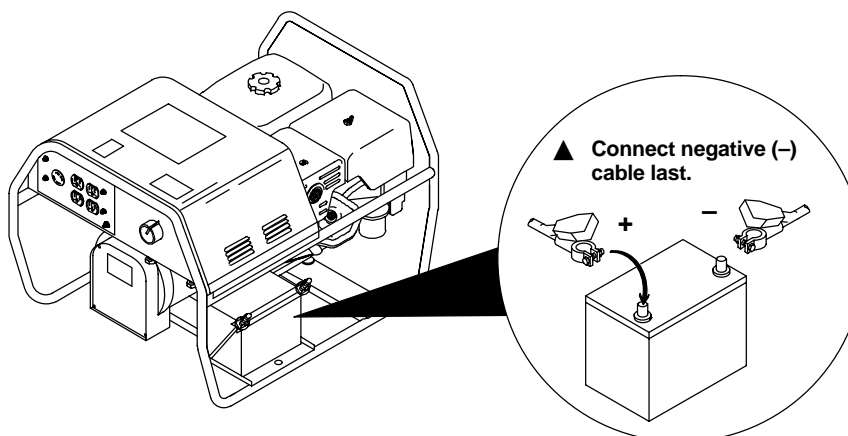

- ▲ Turn Engine Switch to Off (electric-start models only).

Tools Needed:



802 100-A / Ref. S-0756-D

4-7. Connecting To Weld Output Terminals



- 1 Positive (+) Weld Output Terminal
- 2 Negative (-) Weld Output Terminal

For Direct Current Electrode Positive (DCEP), connect work cable to Negative (-) terminal and electrode holder to Positive (+) terminal.

For Direct Current Electrode negative (DCEN), reverse cable connections.

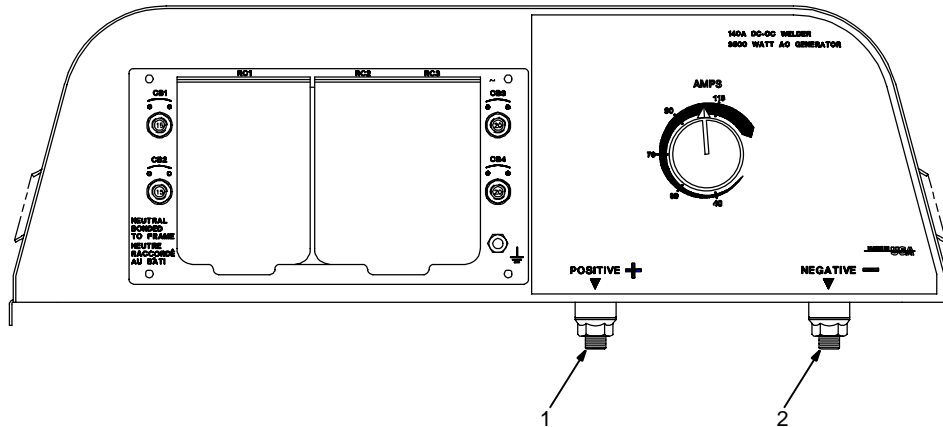

Tools Needed:

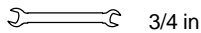

196 921 / 495 179

4-8. Selecting Weld Cable Sizes*

| Weld Output Terminals ▲ Stop engine before connecting to weld output terminals. ▲ Do not use worn, damaged, undersized, or poorly spliced cables. | Weld Cable Size** and Total Cable (Copper) Length in Weld Circuit Not Exceeding*** | | | | | | | |
|--|--|---------------------|----------------------|----------------------|---------------|---------------|------------------|------------------|
| | 100 ft (30 m) or Less | | 150 ft (45 m) | 200 ft (60 m) | 250 ft (70 m) | 300 ft (90 m) | 350 ft (105 m) | 400 ft (120 m) |
| | Welding Amperes | 10 – 60% Duty Cycle | 60 – 100% Duty Cycle | 10 – 100% Duty Cycle | | | | |
| 100 | 4 (20) | 4 (20) | 4 (20) | 3 (30) | 2 (35) | 1 (50) | 1/0 (60) | 1/0 (60) |
| 150 | 3 (30) | 3 (30) | 2 (35) | 1 (50) | 1/0 (60) | 2/0 (70) | 3/0 (95) | 3/0 (95) |
| 200 | 3 (30) | 2 (35) | 1 (50) | 1/0 (60) | 2/0 (70) | 3/0 (95) | 4/0 (120) | 4/0 (120) |
| 250 | 2 (35) | 1 (50) | 1/0 (60) | 2/0 (70) | 3/0 (95) | 4/0 (120) | 2 ea. 2/0 (2x70) | 2 ea. 2/0 (2x70) |

* This chart is a general guideline and may not suit all applications. If cable overheating occurs (normally you can smell it), use next size larger cable.

**Weld cable size (AWG) is based on either a 4 volts or less drop or a current density of at least 300 circular mils per ampere.
() = mm² for metric use

S-0007-E

***For distances longer than those shown in this guide, call a factory applications representative at 920-735-4505.

SECTION 5 – OPERATING THE WELDING GENERATOR

5-1. Controls (Kohler-Powered Units)

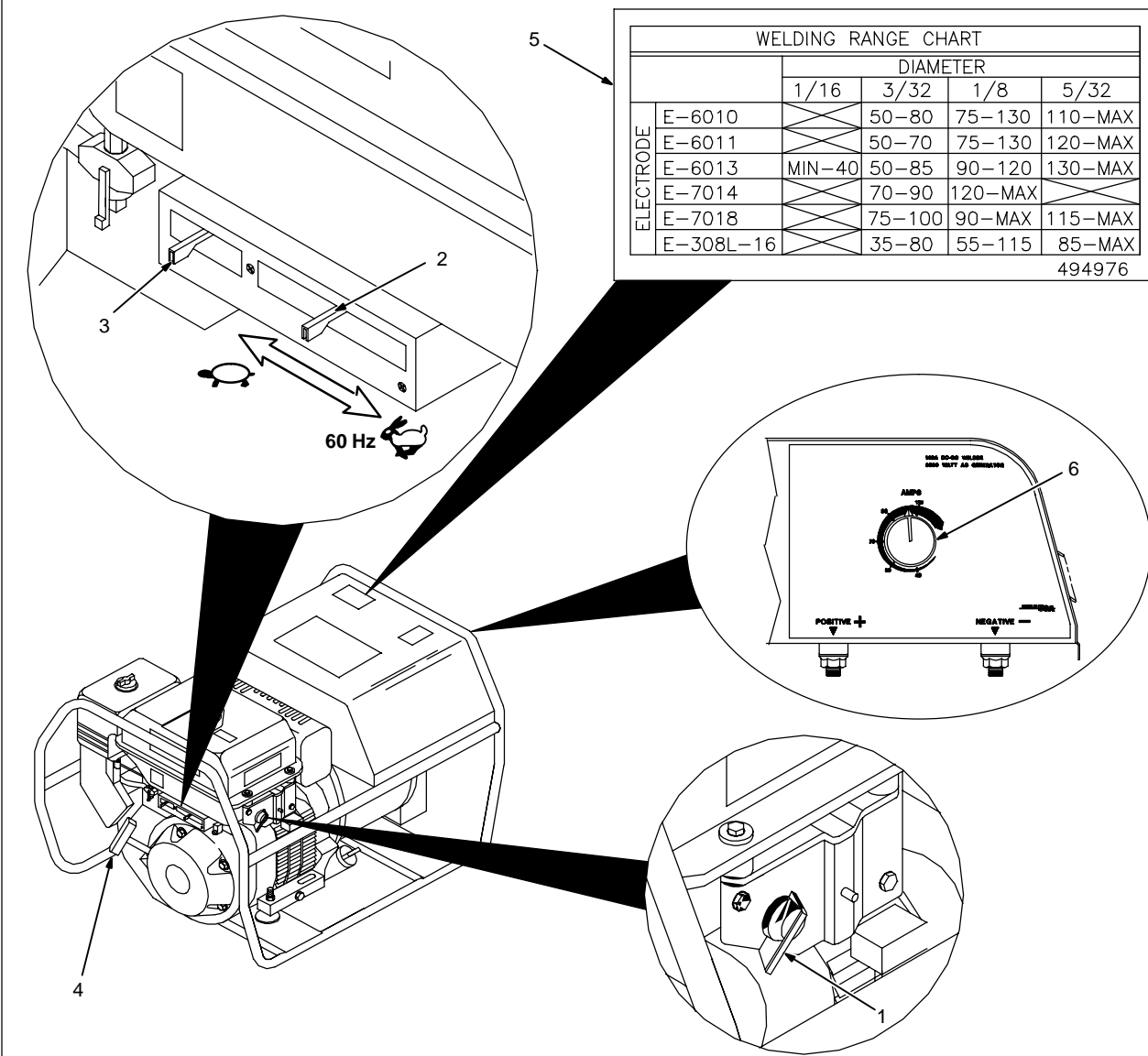

| WELDING RANGE CHART | | | | | |
|-----------------------------------|-----------|--------|--------|---------|---------|
| DIAMETER | | | | | |
| 1/16 3/32 1/8 5/32 | | | | | |
| ELECTRODE | E-6010 | | 50-80 | 75-130 | 110-MAX |
| | E-6011 | | 50-70 | 75-130 | 120-MAX |
| | E-6013 | MIN-40 | 50-85 | 90-120 | 130-MAX |
| | E-7014 | | 70-90 | 120-MAX | |
| | E-7018 | | 75-100 | 90-MAX | 115-MAX |
| | E-308L-16 | | 35-80 | 55-115 | 85-MAX |

494976

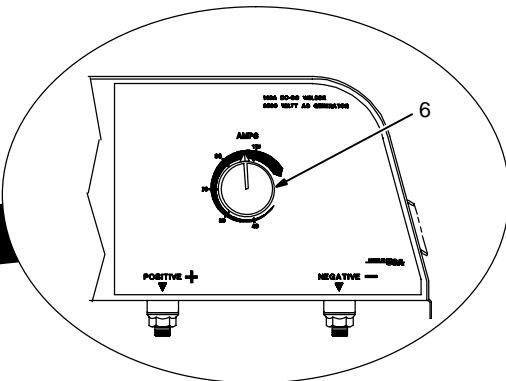

802 512-A / 495 179

☞ *Weld and auxiliary power output stops if generator overheats or engine speed is too low.*

1 Engine Switch

Use switch to open ignition circuit, and to stop engine.

2 Throttle Control Lever

Use lever to select engine speed. Move lever to idle position (far left) for idle speed. Move lever to Run position (far right) for weld/power speed.

☞ *Always place lever in Run position (far right) for auxiliary power and for maximum weld output.*

3 Choke Control Lever

Use lever to change engine air/fuel mix. Move lever to left if starting a cold engine. Move lever to right if starting a warm engine.

4 Starter Handle

To Start: open fuel valve (see Section 4-4), turn engine switch to On, move throttle lever to Idle, set choke, and pull starter handle. Open choke as engine warms.

To Stop: turn engine switch to Off.

☞ *Always close fuel valve after stopping unit. Moving unit with fuel valve open may cause carburetor flooding and make starting difficult.*

5 Welding Range Label

Use label to determine correct weld amperage based on electrode size, type, and material thickness.

6 Current Control

Use control to select weld amperage. Control may be adjusted while welding.

To Set Current Control: Use label to determine correct size electrode for material thickness. Select electrode type and set current control to corresponding amperage range. Adjust control to obtain desired weld performance.

EXAMPLE:

Material Thickness: 1/8 to 1/4 in

Electrode Diameter: 1/8

Electrode Type: E-6013

Current Control Setting: 90 – 120 A

5-2. Controls (Honda-Powered Units) (See Section 5-3)

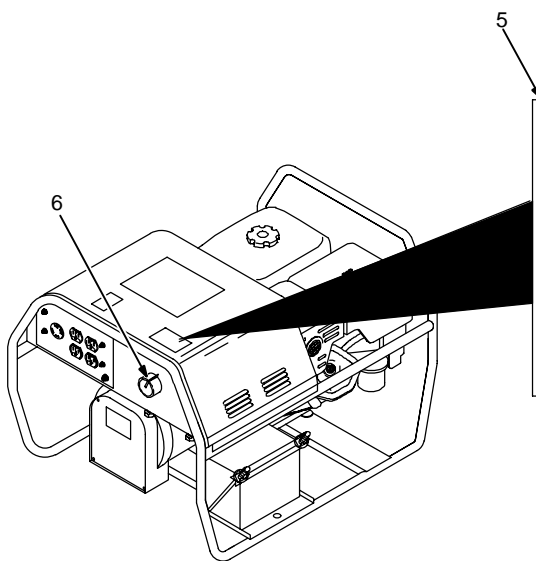
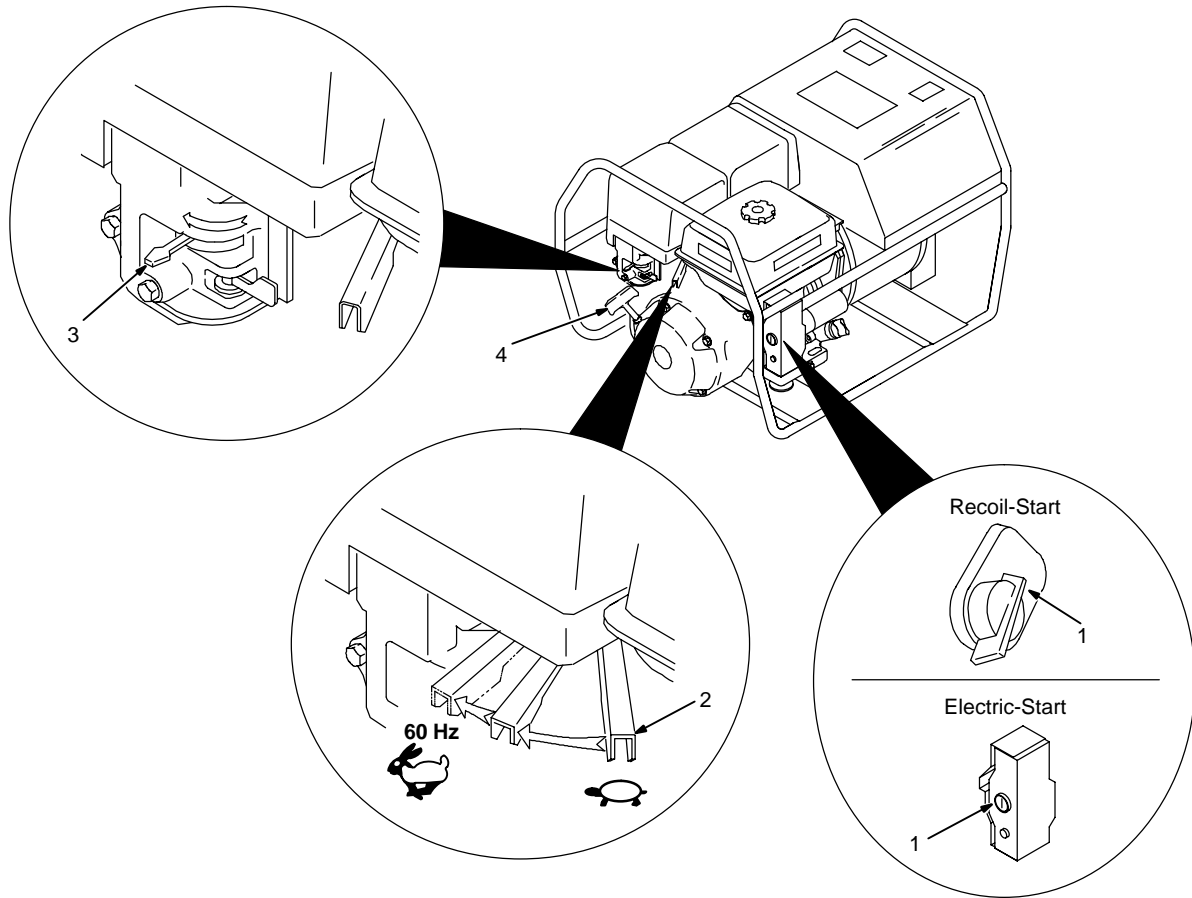

| | | WELDING RANGE CHART | | | |
|-----------|-----------|---------------------|--------|---------|-----------------|
| | | DIAMETER | | | |
| | | 1/16 | 3/32 | 1/8 | 5/32 |
| ELECTRODE | E-6010 | XXXX | 50-80 | 75-130 | 110-MAX |
| | E-6011 | XXXX | 50-70 | 75-130 | 120-MAX |
| | E-6013 | MIN-40 | 50-85 | 90-120 | 130-MAX |
| | E-7014 | XXXX | 70-90 | 120-MAX | XXXX |
| | E-7018 | XXXX | 75-100 | 90-MAX | 115-MAX |
| | E-308L-16 | XXXX | 35-80 | 55-115 | 85-MAX |

SECTION 6 – OPERATING AUXILIARY EQUIPMENT

NOTE

The welding generator provides power while welding and with the Current control in any position. However, under these conditions equipment connected to the welding generator may be subject to larger than normal voltage fluctuations. It is recommended that only lamps be powered under these conditions.

6-1. Auxiliary Power Panel 196 921 (CSA)

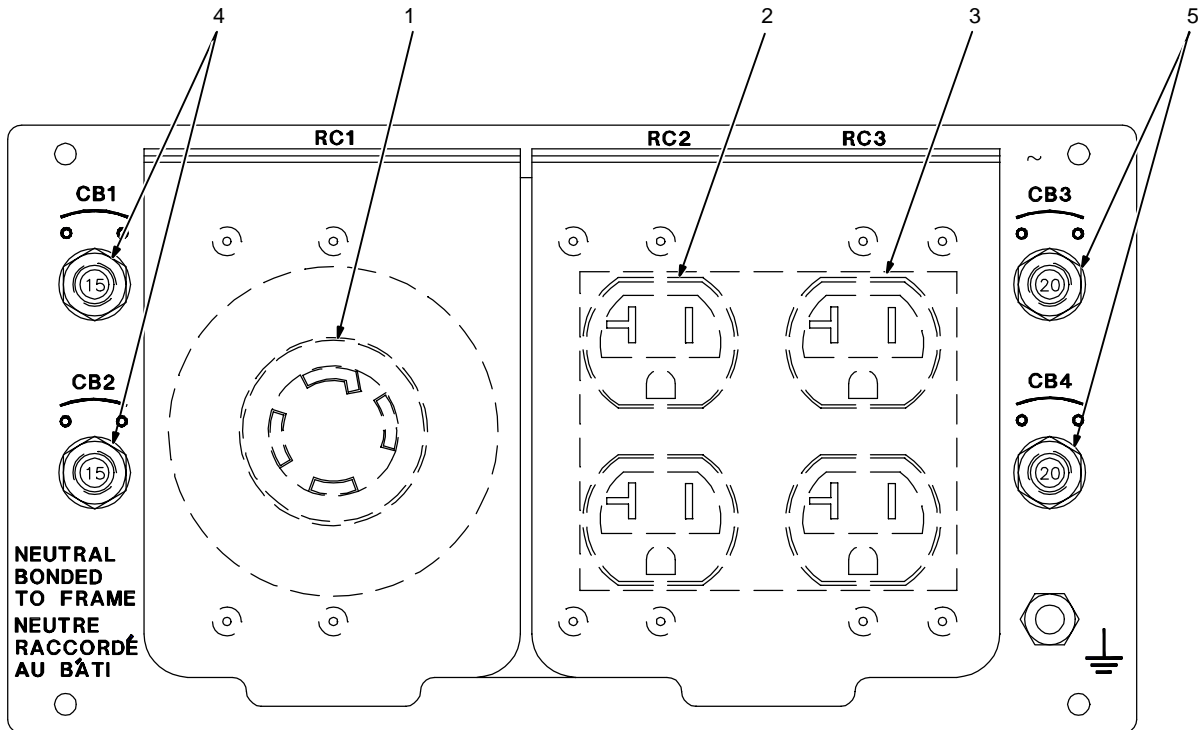

196 921

▲ If unit does not have GFCI receptacles, use GFCI-protected extension cord.

▲ Power is still present at the 240 volt receptacle when only one circuit breaker trips.

Unplug power cord before attempting to service accessories or tools.

 Auxiliary power decreases as weld current increases.

Set Amperage control at max. for full auxiliary power.

 Place throttle lever in Run position (far right) for auxiliary power.

1 240 V AC Twistlock Receptacle RC1

RC1 supplies 60 Hz single-phase power at weld/power speed. Maximum output is 3.5 kVA/kW.

2 120 V 20 A AC Duplex Receptacle RC2

3 120 V 20 A AC Duplex Receptacle RC3

RC2 and RC3 supply 60 Hz single-phase power at weld/power speed. Maximum output from RC2 or RC3 is 2.4 kVA/kW.

 Each receptacle of the duplex can provide 15A/1800W.

 Do not parallel the two 120V duplex receptacles.

4 Circuit Breakers CB1 and CB2

CB1 and CB2 protect RC1 from overload. If CB1 or CB2 opens, RC1 does not work. 120 volts may still be present at RC1.

5 Circuit Breakers CB3 And CB4
CB3 protects RC2 and CB4 protects RC3 from overload. If a circuit breaker opens, the receptacle does not work.

 Press button to reset circuit breaker. If breaker continues to open, contact Factory Authorized Service Agent.

Combined output of all receptacles limited to 3.5 kVA/kW rating of the generator (See Section 10 – Auxiliary Power Guidelines).
EXAMPLE: If 5 A is drawn from each 120 receptacle, only 9 A is available from the 240 V receptacle.

$2 \times (120 \text{ V} \times 5 \text{ A}) + (240 \text{ V} \times 9 \text{ A}) = 3.5 \text{ kVA/KW}$.

6-2. Optional Auxiliary Power Panels

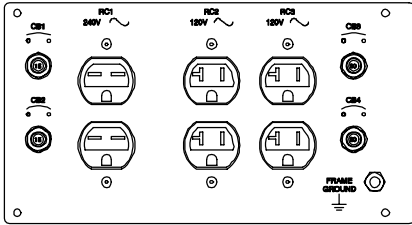

**Auxiliary Power Panel 495 315
(USA)**

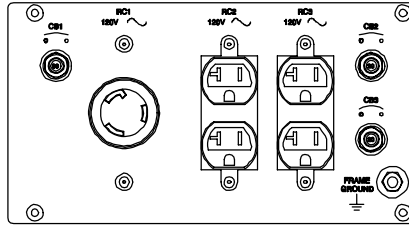

**Auxiliary Power Panel 495 218
(USA)**

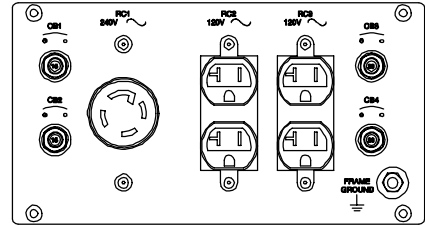

**Auxiliary Power Panel 196 914
(USA)**

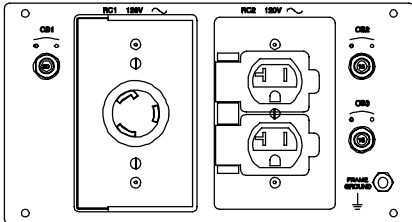

**Auxiliary Power Panel 495 279
(Canada)**

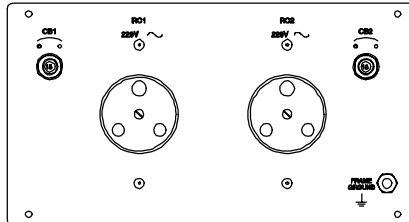

**Auxiliary Power Panel 495 253
(South Africa)**

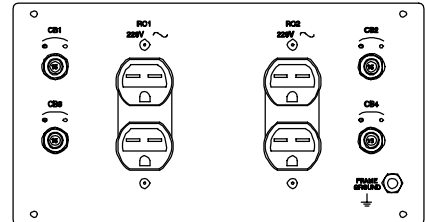

**Auxiliary Power Panel 495 288
(South America)**

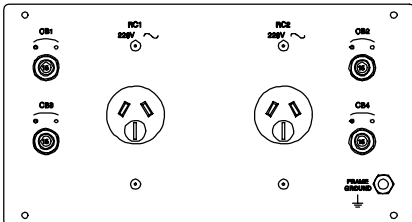

**Auxiliary Power Panel 495 289
(Australia)**

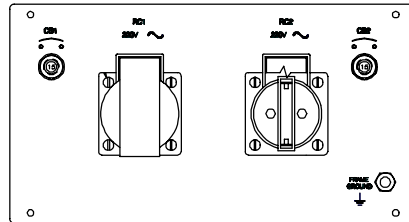

**Auxiliary Power Panel 495 290
(Europe)**

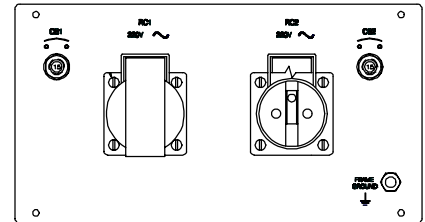

**Auxiliary Power Panel 495 283
(S.E. Asia)**

Ref. ST-802 124 / H-495 290 / H-495 283

- ▲ If unit does not have GFCI receptacles, use GFCI-protected extension cord.
- ▲ Power may still be present at a receptacle when a circuit breaker trips.

Unplug power cord before attempting to service accessories or tools.

☞ Auxiliary power decreases as weld current increases.

Set Amperage control at max. for full auxiliary power.

☞ Place throttle lever in Run position (far right) for auxiliary power.

Circuit breakers protect the generator from overload.

☞ Press button to reset circuit breaker. If breaker continues to open, contact Factory Authorized Service Agent.

6-3. Auxiliary Power Panel Ratings



NOTE



Unless otherwise stated, the rating of duplex outlets is the combined load of all receptacles.

Total power from generator NOT to exceed 3500 Watts (60 Hz)

| Receptacle | Protected By | Panel 196 921 (CSA) | Panel 495 315 (USA) | Panel 495 218 (USA) | Panel 196 914 (USA) | Panel 495 279 (Canada-CSA) | Panel 495 253 (S. Africa) | Panel 495 288 (South America) | Panel 495 289 (Australia) | Panel 495 290 (Europe) | Panel 495 283 (S.E. Asia) |
|---------------------------|----------------|----------------------|----------------------|---------------------|----------------------|----------------------------|---------------------------|-------------------------------|---------------------------|------------------------|---------------------------|
| | | 60 Hz | 60 Hz | 60 Hz | 60 Hz | 60 Hz | 60 Hz | 60 Hz | 60 Hz | 60 Hz | 60 Hz |
| 240 V Twist Lock | CB1,2 | 15A/3500W See Note 2 | | | 15A/3500W See Note 2 | | | | | | |
| 240 V Duplex | CB1,2 | | 15A/3500W See Note 2 | | | | | 15A/3500W | | | |
| 240 V Duplex | CB3,4 | | | | | | | 15A/3500W | | | |
| 230 V Single | CB1 | | | | | | 15A/3500W | | | 15A/3500W | 15A/3500W |
| 230 V Single | CB2 | | | | | | 15A/3500W | | | 15A/3500W | 15A/3500W |
| 230 V Single | CB1,2 | | | | | | | 15A/3500W | | | |
| 230 V Single | CB3,4 | | | | | | | 15A/3500W | | | |
| 120 V Twist Lock | CB1 | | | 30A/3500W | | 30A/3500W | | | | | |
| 120 V Duplex | CB1,2 CB1,3 | | | | | 30A/3500W | | | | | |
| 120 V Duplex | CB2 | | | 20A/2400W | | | | | | | |
| 120 V Duplex | CB3 | 20A/2400W See Note 3 | 20A/2400W See Note 3 | 20A/2400W | 20A/2400W See Note 3 | | | | | | |
| 120 V Duplex | CB4 | 20A/2400W See Note 3 | 20A/2400W See Note 3 | | 20A/2400W See Note 3 | | | | | | |
| Total Power NOT to exceed | | 3500W | 3500W | 3500W | 3500W | 3500W | 3500W | 3500W | 3500W | 3500W | 3500W |

- Notes: 1. Each receptacle of the duplex can provide 15A/1800W. Do not parallel the two 120V duplex receptacles.
 2. Do not parallel the two 120V circuits.
 3. Do not parallel the two duplex outlets.

Calculating total power provided by generator. (See Section 10 – Auxiliary Power Guidelines)

Each receptacle can provide the watts or amps as shown above. However, the total power can not exceed 3500W.

The rating plate on electrical apparatus will contain the watts consumed or the rated input amps. Watts may be calculated by multiplying the rated voltage by the rated input amps.

$$\text{watts} = \text{volts} \times \text{amps}$$

For example, for the 495 218 Auxiliary Power Panel,

| | | |
|-------------------------|--------------|---------------------|
| 120V, 1500W heater | 1500W | |
| 120V, 10A chain saw | 1200W | |
| 120V, 500W halogen lamp | 500W | |
| Total | 3200W | This loading is OK. |

| | | |
|-------------------------|--------------|--|
| 120V, 1500W heater | 1500W | |
| 120V, 10A chain saw | 1200W | |
| 120V, 5A router | 600W | |
| 120V, 500W halogen lamp | 500W | |
| Total | 3800W | This loading is <u>not</u> OK. It exceeds 3500W. |

6-4. Wiring Instructions For Optional 120/240 Volt Twistlock Plug (NEMA L14-30P)

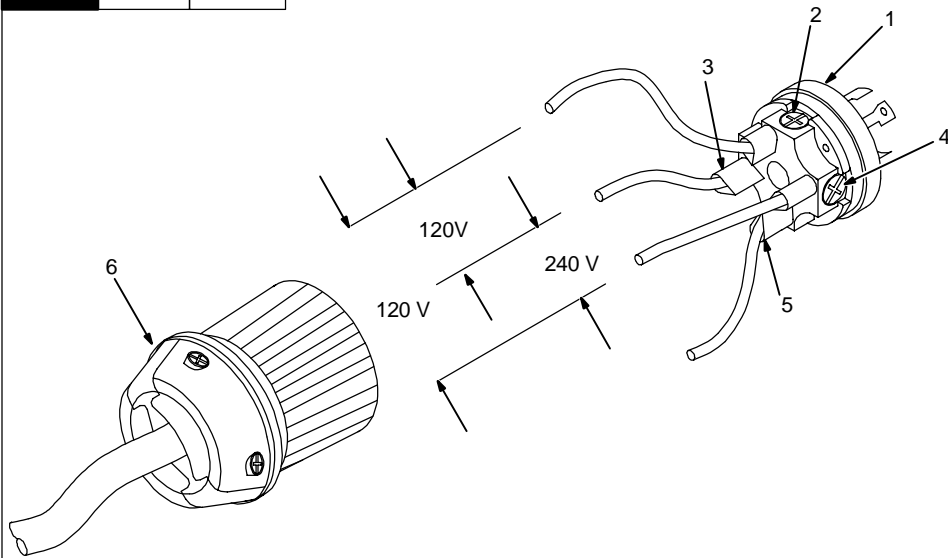

1 Plug Wired For 120/240 V, 3-Wire Load

When wired for 120 V loads, each duplex receptacle shares a load with one half of the 240 V receptacle.

2 Neutral (Silver) Terminal

3 Load 1 (Brass) Terminal

4 Load 2 (Brass) Terminal

5 Ground (Green) Terminal

6 Cord Grip

Strip cord jacket back enough to separate conductors.

Strip conductors enough to make good contact with plug terminals. Make plug connections and reinstall outer shell and cord grip.

Tighten assembly screws onto shell. Do not overtighten.

Tools Needed:

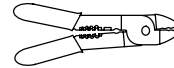

plug3-11/99 – 802 527

Notes

SECTION 7 – MAINTENANCE

7-1. Routine Maintenance

| | | | |
|--|--|---|--|
| | | <p>Recycle engine fluids.</p> | <p>▲ Stop engine before maintaining.</p> <p> See Engine Manual and Maintenance Label. Service more often if used in severe conditions.</p> <p>* To be done by Factory Authorized Service Agent.</p> |
| 8 h | | 20 h | |
| <p>Check fluid levels. See Section 4-4 or 4-5.</p> | | <p>Wipe up spills.</p> | |
| <p>Check and clean spark arrestor screen. See engine manual.</p> | | | |
| 50 h | | | |
| <p>Service air cleaner element. See engine manual.</p> | | <p>Clean and tighten weld terminals.</p> | |
| 100 h | | | |
| <p>Change oil. See engine manual and maintenance label.</p> | | <p>Check spark plugs.</p> | |
| <p>Clean Fuel sediment cup.</p> | | <p>Clean and tighten battery connections (Electric-Start models only).</p> | |
| 200 h | | | |
| <p>Clean fuel tank and strainer.</p> | | <p>Replace unreadable labels.</p> | |
| 300 h | | | |
| | | <p>Check valve clearance.*</p> | |
| 500 h | | | |
| <p>Repair or replace cracked cables.</p> | | <p>Service welding generator brushes and slip rings. Service more often in dirty conditions.*</p> | |
| 1000 h | | | |
| | | <p>Blow out or vacuum inside. During heavy service, clean monthly.</p> | |

NOTE

Follow the storage procedure in the engine owner's manual if the unit will not be used for an extended period.

7-2. Maintenance Label

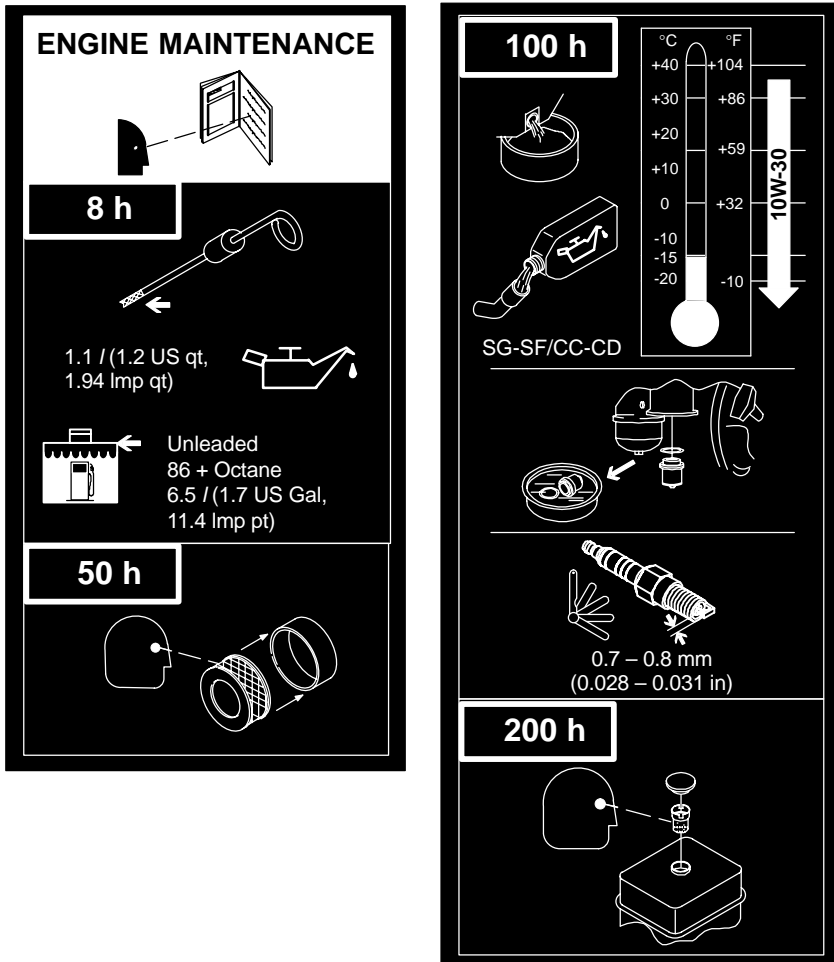

ENGINE MAINTENANCE

8 h

1.1 / (1.2 US qt, 1.94 Imp qt)

Unleaded 86 + Octane
6.5 / (1.7 US Gal, 11.4 Imp pt)

50 h

100 h

SG-SF/CC-CD



0.7 – 0.8 mm
(0.028 – 0.031 in)

200 h

Temperature scale: °C (+40, +30, +20, +10, 0, -10, -15, -20) and °F (+104, +86, +59, +32, -10). Arrow indicates 10W-30 oil.

Ref. S-175 679-A

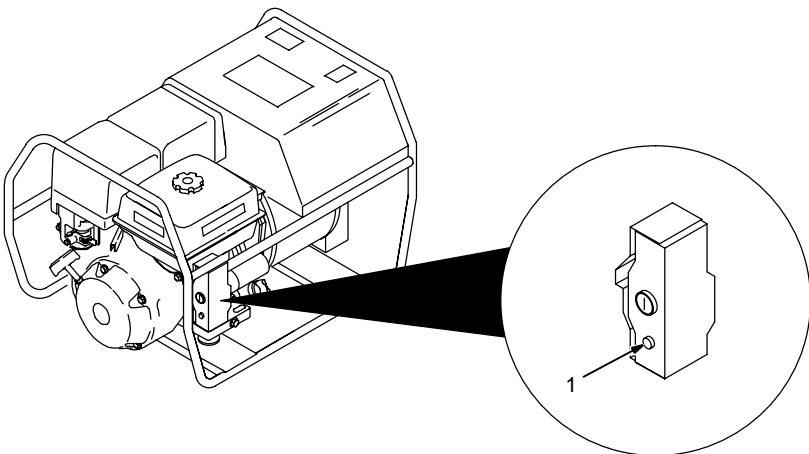
7-3. Overload Protection (Honda-Powered Units Only)



1 Ignition Circuit Breaker (Electric-Start Models Only)

The circuit breaker protects the engine battery charging circuit. A short circuit or a battery connected in reverse polarity will trip the circuit breaker.



Press button to reset breaker.

 If a switch or breaker opens, it usually indicates a more serious problem exists. Contact a Factory Authorized Service Agent.

Ref. 802 099-A

7-4. Adjusting Engine Speed (Kohler-Powered Units)



| | |
|---|-----------------------|
|  | |
|  | 2000 ± 150 rpm |
|  | 3720 ± 50 rpm (60 Hz) |

After tuning engine, check engine speeds. See table for proper no load speeds. If necessary, adjust speeds as follows:

Start engine and run until warm.

Weld/Power Speed Adjustment

- 1 Throttle Control Lever
- 2 Adjustment Screw

Move lever to Run (far right) position. To increase speed, turn screw out (counterclockwise) while lightly pushing lever to the right. To decrease speed, turn screw in (clockwise).

Idle Speed Adjustment

- 3 Adjustment Screw

Move lever to idle (far left) position. To increase idle speed, turn screw in (clockwise). To decrease idle speed, turn screw out (counterclockwise).

▲ **Stop engine. Close fuel valve.**

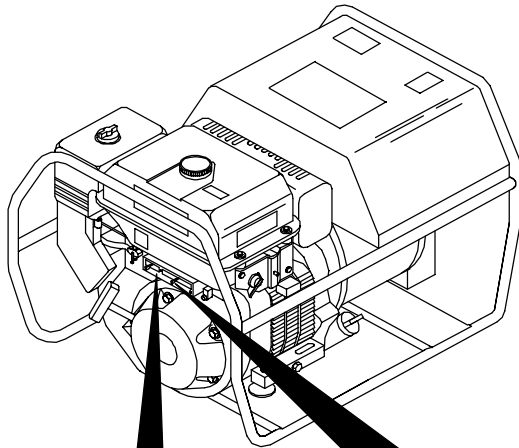

Top View

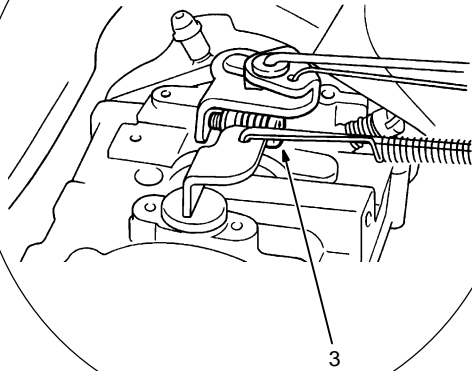

Top View

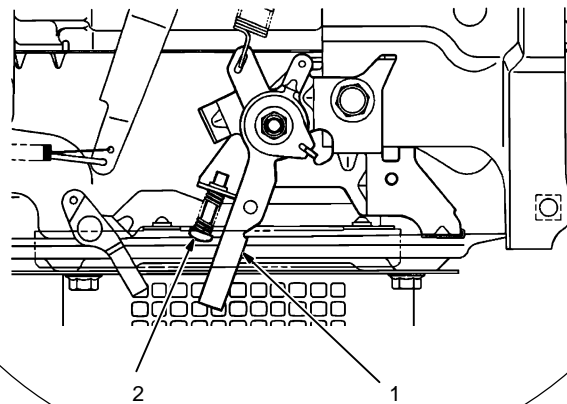



Tools Needed:

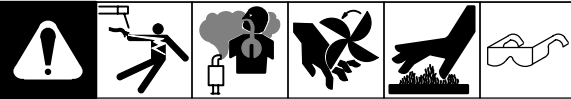

7-5. Adjusting Engine Speed (Honda-Powered Units)



| | |
|---|-----------------------|
|  | |
|  | 1400 ± 150 rpm |
|  | 3720 ± 50 rpm (60 Hz) |

After tuning engine, check engine speeds. See table for proper no load speeds. If necessary, adjust speeds as follows:

Start engine and run until warm.

Weld/Power Speed Adjustment

- 1 Throttle Control Lever
- 2 Adjustment Screw

Move lever to Run (far left) position. Turn screw and move lever until engine runs at weld/power speed.

Idle Speed Adjustment

- 3 Pilot Screw
- 4 Throttle Stop Screw

Move lever to idle (far right) position. Turn pilot screw until engine runs at highest idle speed. Turn stop screw until engine runs at rated idle speed (normally about 2-1/4 turns out.)

▲ **Stop engine. Close fuel valve.**

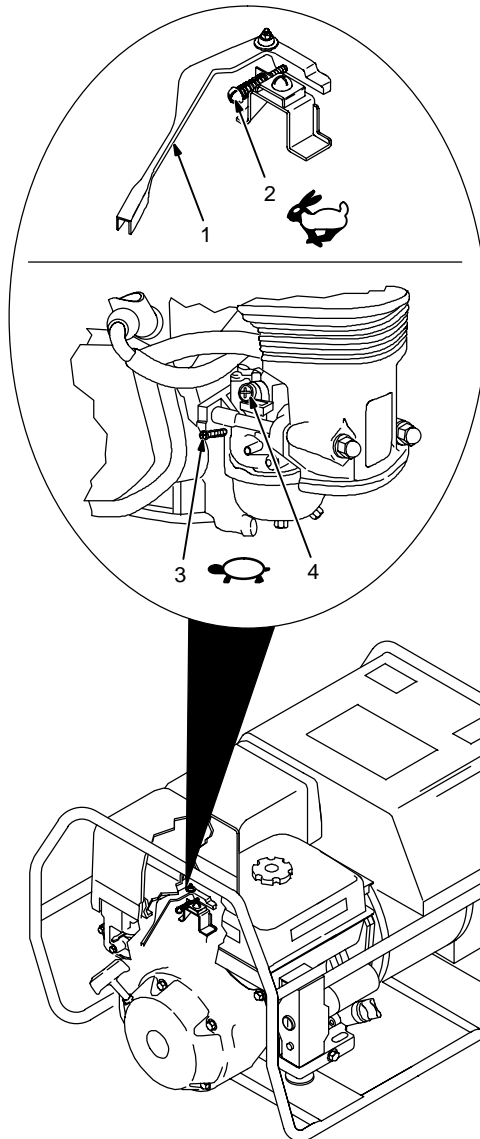

Tools Needed:

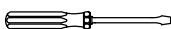

 1/4, 3/8 in

SECTION 8 – TROUBLESHOOTING

8-1. Troubleshooting

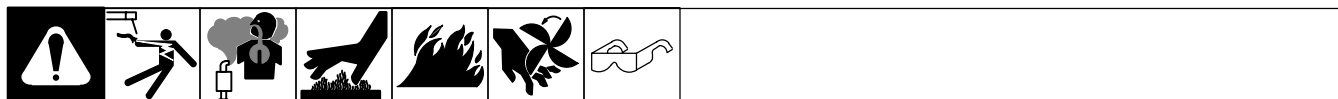

A. Welding

| Trouble | Remedy |
|----------------------|--|
| No weld output. | Check Amperage control setting. |
| | Check weld connections. |
| | Be sure all equipment is disconnected from receptacles when starting unit. |
| | Have Factory Authorized Service Agent check brushes, slip rings, rotor, stator, reactor L2, output rectifier CR3, stabilizer L3, integrated rectifiers CR1 and CR2, and amperage control R1. |
| Low weld output. | Check Amperage control and throttle lever settings. |
| | Check engine speed, and adjust if necessary (see Section 7-4 or 7-5). |
| | Service air cleaner according to engine manual. |
| | Check weld cable size and length. |
| High weld output. | Check Amperage control setting. |
| | Check engine speed, and adjust if necessary (see Section 7-4 or 7-5). |
| Erratic weld output. | Check Amperage control setting. |
| | Tighten and clean connections to electrode and workpiece. |
| | Use dry, properly-stored electrodes for Stick welding. |
| | Remove excessive coils from weld cables. |
| | Clean and tighten connections both inside and outside welding generator. |
| | Check engine speed, and adjust if necessary (see Section 7-4 or 7-5). |
| | Check throttle/governor linkage for smooth, non-binding operation. |

B. Auxiliary Power

| Trouble | Remedy |
|---|--|
| No output at auxiliary power receptacles. | Reset circuit breakers (see Section 6-1). |
| | Check receptacle wiring and connections. |
| | Check engine speed, and adjust if necessary (see Section 7-4 or 7-5). Output stops if engine speed is too low. |
| | Have Factory Authorized Service Agent check stator windings. |
| High power output. | Check engine speed, and adjust if necessary (see Section 7-4 or 7-5). |
| Low power output. | Check Amperage control setting. |
| | Check engine speed, and adjust if necessary (see Section 7-4 or 7-5). Output stops if engine speed is too low. |
| | Move throttle lever to Run (far right) position (see Section 5-1 or 5-2). |
| Erratic power output. | Check fuel level. |
| | Check receptacle wiring and connections. |
| | Check throttle/governor linkage for smooth, non-binding operation. |
| | Service air cleaner according to engine manual. |
| | Check engine speed, and adjust if necessary (see Section 7-4 or 7-5). Output stops if engine speed is too low. |

C. Engine

| Trouble | Remedy |
|---|---|
| Engine will not crank (Honda electric-start models only). | Reset ignition circuit breaker (see Section 7-3). |
| | Check battery voltage. |
| | Check battery connections and tighten if necessary. |
| | Have Factory Authorized Service Agent check engine ignition circuit. |
| Engine will not start. | Check fuel level (see Section 4-4 or 4-5). |
| | Open fuel valve (see Section 4-4 or 4-5). Close fuel valve before moving unit or carburetor may flood and make starting difficult. |
| | Check battery voltage (Honda electric-start models only). |
| | Check battery connections and tighten if necessary (Honda electric-start models only). |
| | Check oil level (see Section 4-4 or 4-5). Engine stops if oil level is too low. Refill crankcase with proper viscosity oil for operating temperature. |
| | Have Factory Authorized Service Agent check low oil level shutdown switch. |
| Engine stopped during normal operation. | Check fuel level (see Section 4-4 or 4-5). |
| | Open fuel valve (see Section 4-4 or 4-5). Close fuel valve before moving unit or carburetor may flood and make starting difficult. |
| | Check oil level (see Section 4-4 or 4-5). Engine stops if oil level is too low. |
| Battery discharges between uses (electric-start models only). | Clean battery, terminals, and posts with baking soda and water solution; rinse with clear water. |
| | Periodically recharge battery (approximately every 3 months). |
| | Replace battery. |
| | Check voltage regulator and connections according to engine manual. |
| Unstable or sluggish engine speeds. | Check engine speed, and adjust if necessary (see Section 7-4 or 7-5). |
| | Check throttle/governor linkage for smooth, non-binding operation. |
| | Tune-up engine according to engine manual. |

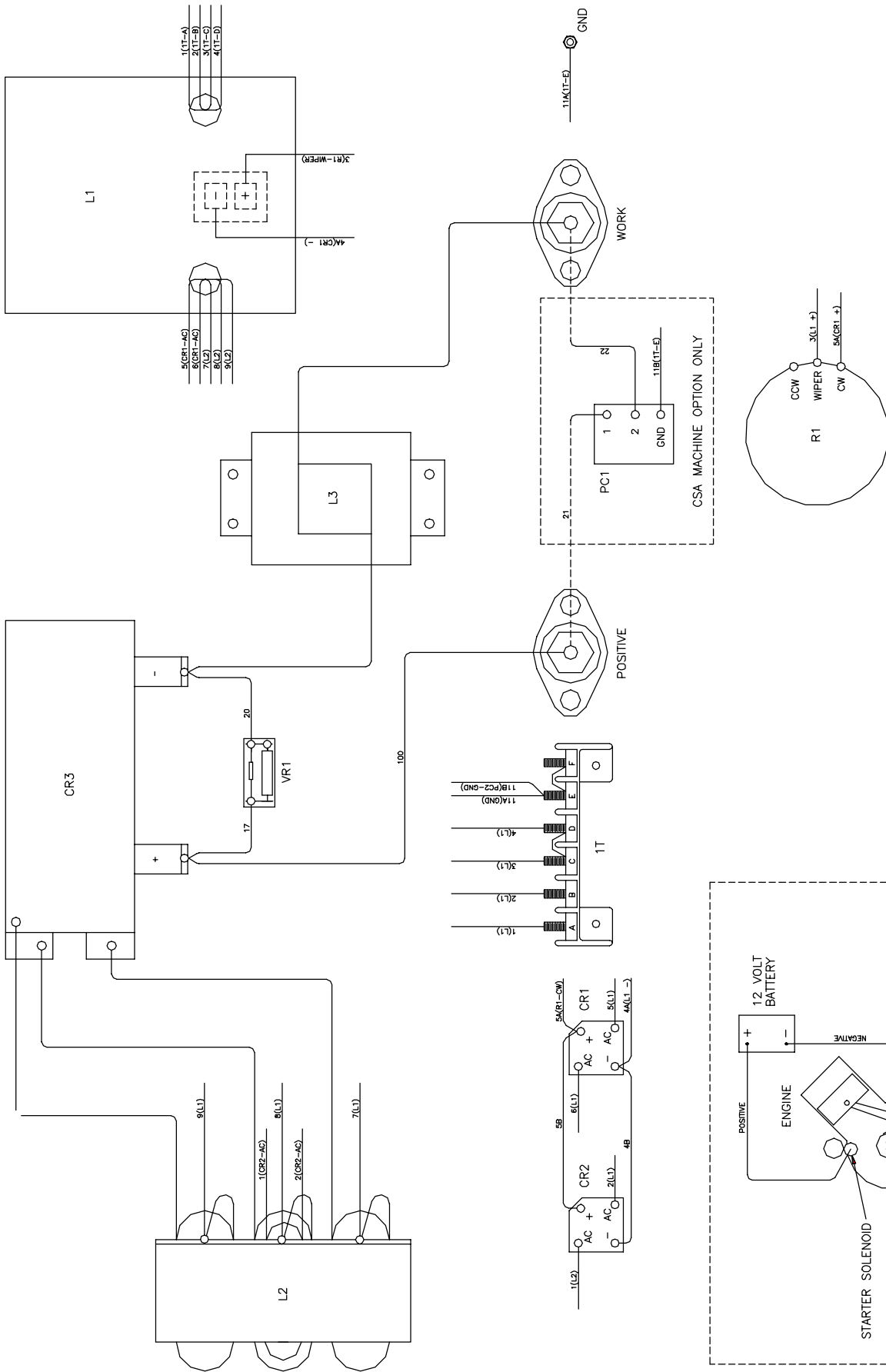

⚠ WARNING
 Do not touch live electrical parts.
 Disconnect input power or stop engine before servicing.
 Do not operate with covers removed.
 Have only qualified persons install, use, or service this unit.

ELECTRIC SHOCK HAZARD

Figure 9-2. Wiring Diagram For Welding Generator

| | |
|---|--|
|  | ⚠ WARNING <ul style="list-style-type: none"> Do not touch live electrical parts. Disconnect input power or stop engine before servicing. Do not operate with covers removed. Have only qualified persons install, use, or service this unit. |
| | ELECTRIC SHOCK HAZARD |

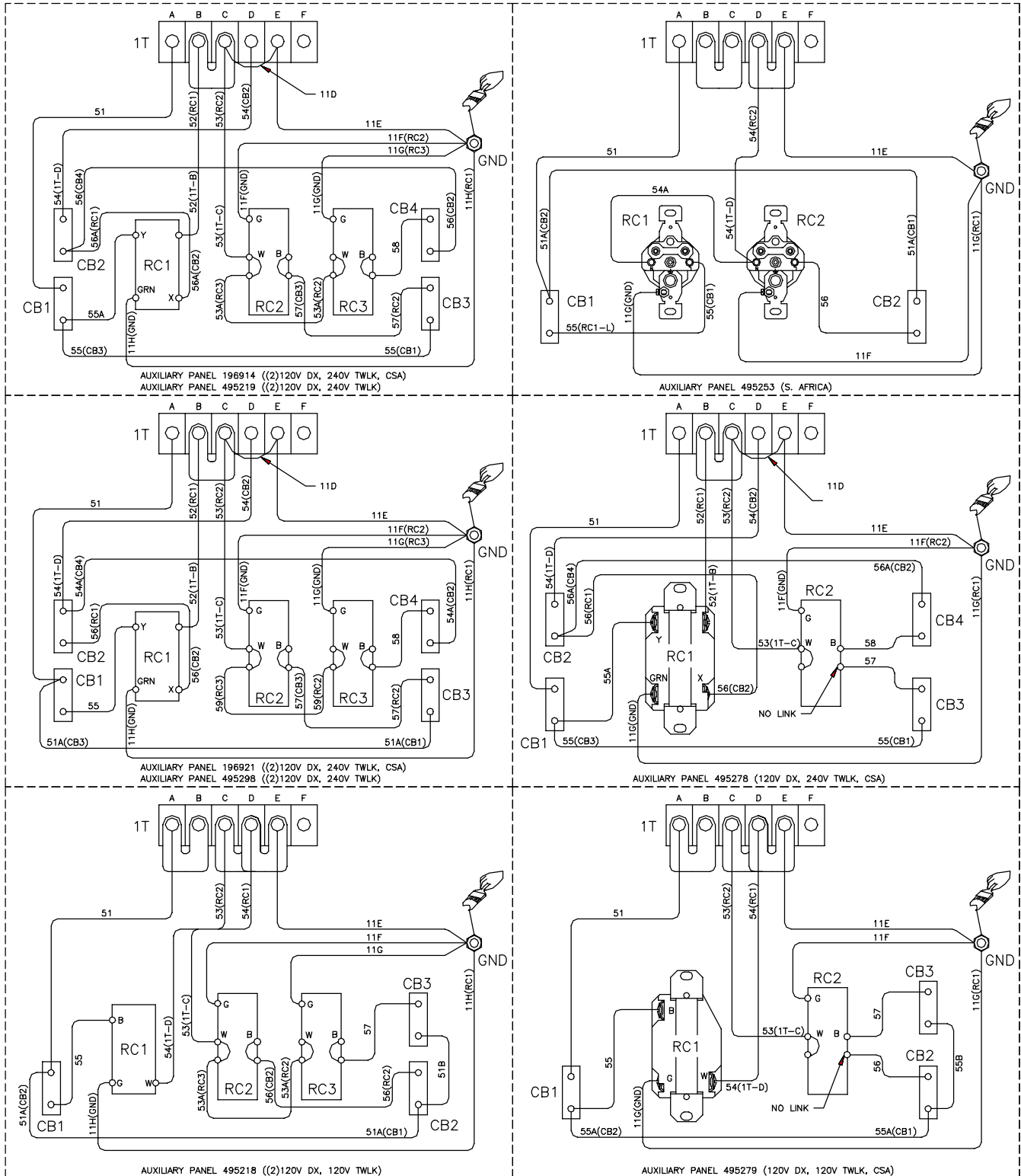



Figure 9-3. Wiring Diagram For Auxiliary Power Panels (1 Of 2)

| | |
|--|--|
|  ⚠ WARNING ELECTRIC SHOCK HAZARD | <ul style="list-style-type: none"> Do not touch live electrical parts. Disconnect input power or stop engine before servicing. Do not operate with covers removed. Have only qualified persons install, use, or service this unit. |
|--|--|

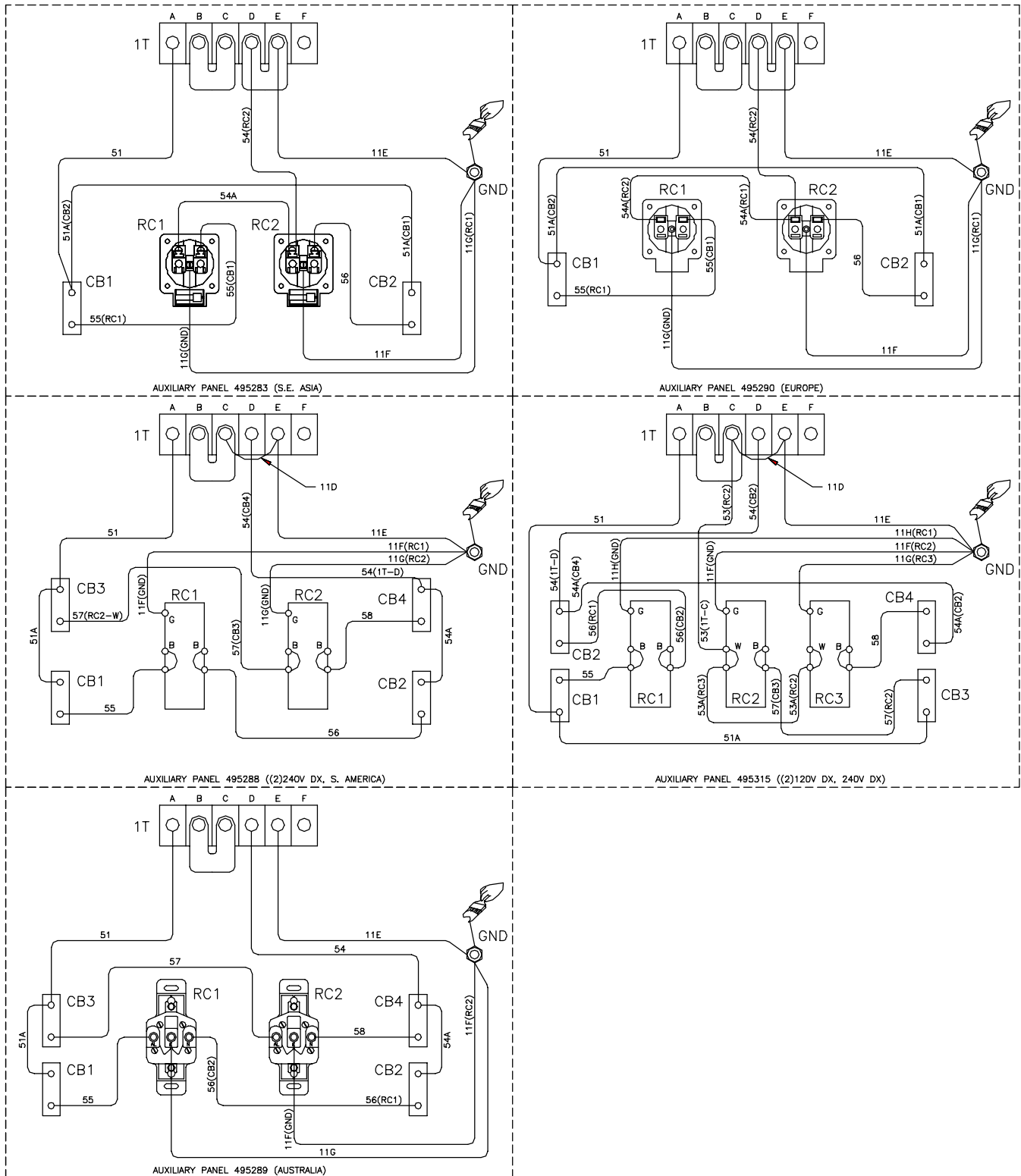

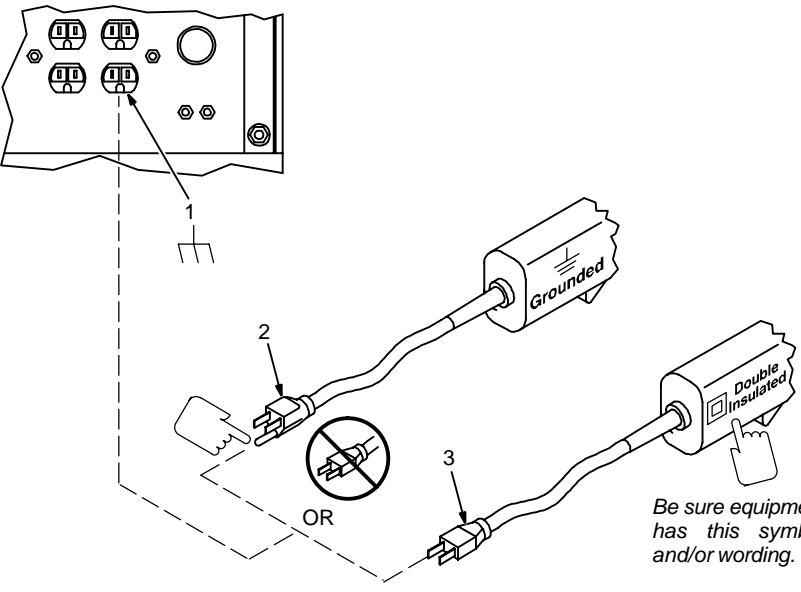

Figure 9-4. Wiring Diagram For Auxiliary Power Panels (2 Of 2)

SECTION 10 – AUXILIARY POWER GUIDELINES

10-1. Selecting Equipment





Be sure equipment has this symbol and/or wording.

- 1 Auxiliary Power Receptacles – Neutral Bonded To Frame
- 2 3-Prong Plug From Case Grounded Equipment
- 3 2-Prong Plug From Double Insulated Equipment

aux_pwr 2/99 – Ref. ST-159 730 / ST-800 577

10-2. Grounding Generator To Truck Or Trailer Frame

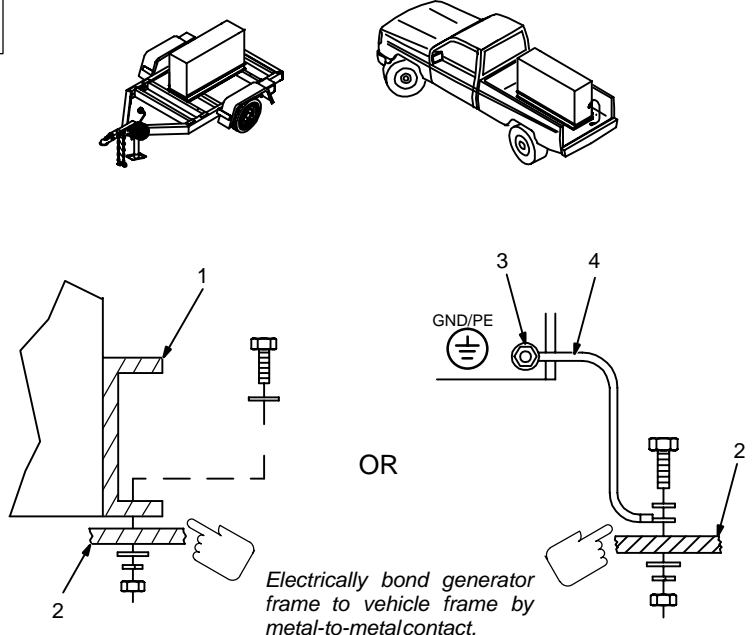

Electrically bond generator frame to vehicle frame by metal-to-metal contact.

- 1 Generator Base
- 2 Metal Vehicle Frame
- 3 Equipment Grounding Terminal
- 4 Grounding Cable

Use #10 AWG or larger insulated copper wire.

▲ If unit does not have GFCI receptacles, use GFCI-protected extension cord.

S-0854

10-3. Grounding When Supplying Building Systems

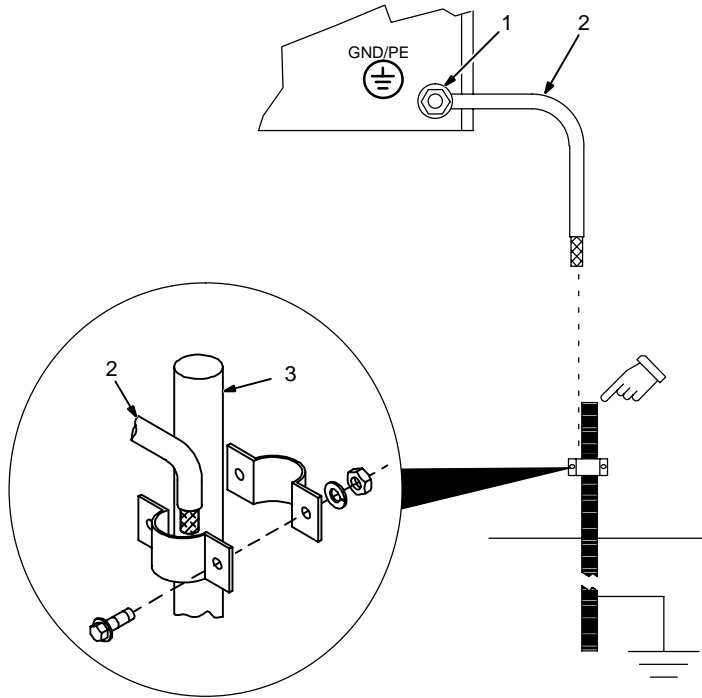

- 1 Equipment Grounding Terminal
 - 2 Grounding Cable
Use #10 AWG or larger insulated copper wire.
 - 3 Ground Device
- ▲ **Ground generator to system earth ground if supplying power to a premises (home, shop, farm) wiring system.**

Use ground device as stated in electrical codes.

ST-800 576-B

10-4. How Much Power Does Equipment Require?

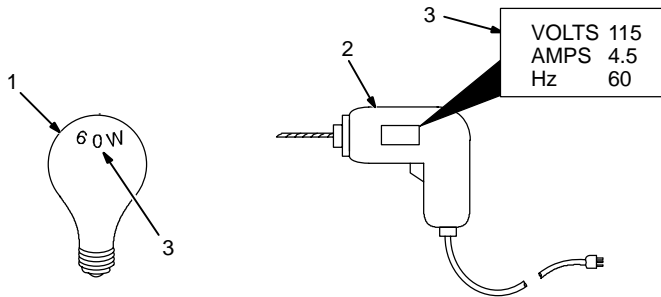

- 1 Resistive Load
A light bulb is a resistive load and requires a constant amount of power.
- 2 Non-Resistive Load
Equipment with a motor is a non-resistive load and requires approximately six times more power while starting the motor than when running (see Section 10-8).
- 3 Rating Data
Rating shows volts and amperes, or watts required to run equipment.

AMPERES x VOLTS = WATTS

EXAMPLE 1: If a drill uses 4.5 amperes at 115 volts, calculate its running power requirement in watts.

$$4.5 \text{ A} \times 115 \text{ V} = 520 \text{ W}$$

The load applied by the drill is 520 watts.

EXAMPLE 2: If three 200 watt flood lamps are used with the drill from Example 1, add the individual loads to calculate total load.

$$(200 \text{ W} + 200 \text{ W} + 200 \text{ W}) + 520 \text{ W} = 1120 \text{ W}$$

The total load applied by the three flood lamps and drill is 1120 watts.

S-0623

10-5. Approximate Power Requirements For Industrial Motors

| Industrial Motors | Rating | Starting Watts | Running Watts |
|-------------------------------|----------|----------------|---------------|
| Split Phase | 1/8 HP | 800 | 300 |
| | 1/6 HP | 1225 | 500 |
| | 1/4 HP | 1600 | 600 |
| | 1/3 HP | 2100 | 700 |
| | 1/2 HP | 3175 | 875 |
| Capacitor Start-Induction Run | 1/3 HP | 2020 | 720 |
| | 1/2 HP | 3075 | 975 |
| | 3/4 HP | 4500 | 1400 |
| | 1 HP | 6100 | 1600 |
| | 1-1/2 HP | 8200 | 2200 |
| | 2 HP | 10550 | 2850 |
| | 3 HP | 15900 | 3900 |
| | 5 HP | 23300 | 6800 |
| | 1-1/2 HP | 8100 | 2000 |
| Capacitor Start-Capacitor Run | 5 HP | 23300 | 6000 |
| | 7-1/2 HP | 35000 | 8000 |
| | 10 HP | 46700 | 10700 |
| Fan Duty | 1/8 HP | 1000 | 400 |
| | 1/6 HP | 1400 | 550 |
| | 1/4 HP | 1850 | 650 |
| | 1/3 HP | 2400 | 800 |
| | 1/2 HP | 3500 | 1100 |

10-6. Approximate Power Requirements For Farm/Home Equipment

| Farm/Home Equipment | Rating | Starting Watts | Running Watts |
|----------------------------|----------|----------------|---------------|
| Stock Tank De-Icer | | 1000 | 1000 |
| Grain Cleaner | 1/4 HP | 1650 | 650 |
| Portable Conveyor | 1/2 HP | 3400 | 1000 |
| Grain Elevator | 3/4 HP | 4400 | 1400 |
| Milk Cooler | | 2900 | 1100 |
| Milker (Vacuum Pump) | 2 HP | 10500 | 2800 |
| FARM DUTY MOTORS | 1/3 HP | 1720 | 720 |
| Std. (e.g. Conveyors, | 1/2 HP | 2575 | 975 |
| Feed Augers, Air | 3/4 HP | 4500 | 1400 |
| Compressors) | 1 HP | 6100 | 1600 |
| | 1-1/2 HP | 8200 | 2200 |
| | 2 HP | 10550 | 2850 |
| | 3 HP | 15900 | 3900 |
| | 5 HP | 23300 | 6800 |
| High Torque (e.g. Barn | 1-1/2 HP | 8100 | 2000 |
| Cleaners, Silo Unloaders, | 5 HP | 23300 | 6000 |
| Silo Hoists, Bunk Feeders) | 7-1/2 HP | 35000 | 8000 |
| | 10 HP | 46700 | 10700 |
| 3-1/2 cu. ft. Mixer | 1/2 HP | 3300 | 1000 |
| High Pressure 1.8 Gal/Min | 500 PSI | 3150 | 950 |
| Washer 2 gal/min | 550 PSI | 4500 | 1400 |
| 2 gal/min | 700 PSI | 6100 | 1600 |
| Refrigerator or Freezer | | 3100 | 800 |
| Shallow Well Pump | 1/3 HP | 2150 | 750 |
| | 1/2 HP | 3100 | 1000 |
| Sump Pump | 1/3 HP | 2100 | 800 |
| | 1/2 HP | 3200 | 1050 |

10-7. Approximate Power Requirements For Contractor Equipment

| Contractor | Rating | Starting Watts | Running Watts |
|----------------------|------------------|----------------|---------------|
| Hand Drill | 1/4 in | 350 | 350 |
| | 3/8 in | 400 | 400 |
| | 1/2 in | 600 | 600 |
| Circular Saw | 6-1/2 in | 500 | 500 |
| | 7-1/4 in | 900 | 900 |
| | 8-1/4 in | 1400 | 1400 |
| Table Saw | 9 in | 4500 | 1500 |
| | 10 in | 6300 | 1800 |
| Band Saw | 14 in | 2500 | 1100 |
| Bench Grinder | 6 in | 1720 | 720 |
| | 8 in | 3900 | 1400 |
| | 10 in | 5200 | 1600 |
| Air Compressor | 1/2 HP | 3000 | 1000 |
| | 1 HP | 6000 | 1500 |
| | 1-1/2 HP | 8200 | 2200 |
| | 2 HP | 10500 | 2800 |
| Electric Chain Saw | 1-1/2 HP, 12 in | 1100 | 1100 |
| | 2 HP, 14 in | 1100 | 1100 |
| Electric Trimmer | Standard 9 in | 350 | 350 |
| | Heavy Duty 12 in | 500 | 500 |
| Electric Cultivator | 1/3 HP | 2100 | 700 |
| Elec. Hedge Trimmer | 18 in | 400 | 400 |
| Flood Lights | HID | 125 | 100 |
| | Metal Halide | 313 | 250 |
| | Mercury | 1000 | |
| | Sodium | 1400 | |
| | Vapor | 1250 | 1000 |
| Submersible Pump | 400 gph | 600 | 200 |
| Centrifugal Pump | 900 gph | 900 | 500 |
| Floor Polisher | 3/4 HP, 16 in | 4500 | 1400 |
| | 1 HP, 20 in | 6100 | 1600 |
| High Pressure Washer | 1/2 HP | 3150 | 950 |
| | 3/4 HP | 4500 | 1400 |
| | 1 HP | 6100 | 1600 |
| 55 gal Drum Mixer | 1/4 HP | 1900 | 700 |
| Wet & Dry Vac | 1.7 HP | 900 | 900 |
| | 2-1/2 HP | 1300 | 1300 |

10-8. Power Required To Start Motor

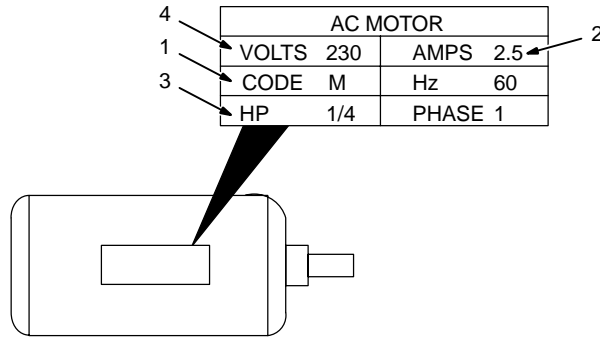

- 1 Motor Start Code
- 2 Running Amperage
- 3 Motor HP
- 4 Motor Voltage

To find starting amperage:

Step 1: Find code and use table to find kVA/HP. If code is not listed, multiply running amperage by six to find starting amperage.

Step 2: Find Motor HP and Volts.

Step 3: Determine starting amperage (see example).

Welding generator amperage output must be at least twice the motor's running amperage.

Single-Phase Induction Motor Starting Requirements

| Motor Start Code | G | H | J | K | L | M | N | P |
|------------------|-----|-----|-----|-----|------|------|------|------|
| KVA/HP | 6.3 | 7.1 | 8.0 | 9.0 | 10.0 | 11.2 | 12.5 | 14.0 |

$$\frac{\text{kVA/HP} \times \text{HP} \times 1000}{\text{VOLTS}} = \text{STARTING AMPERAGE}$$

EXAMPLE: Calculate the starting amperage required for a 230 V, 1/4 HP motor with a motor start code of M.

Volts = 230 HP = 1/4 Using Table, Code M results in kVA/HP = 11.2

$$\frac{11.2 \times 1/4 \times 1000}{230} = 12.2 \text{ A} \quad \text{Starting the motor requires 12.2 amperes.}$$

S-0624

10-9. How Much Power Can Generator Supply?

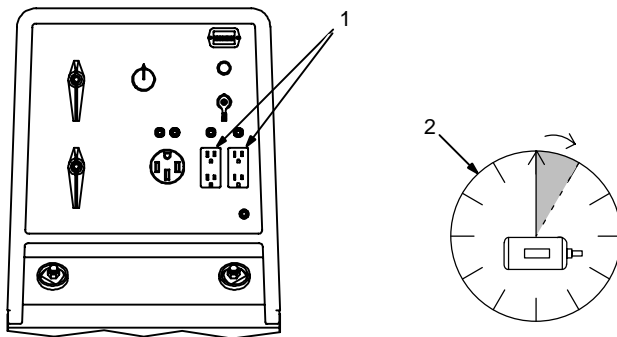

- 1 Limit Load To 90% Of Generator Output

Always start non-resistive (motor) loads in order from largest to smallest, and add resistive loads last.

- 2 5 Second Rule

If motor does not start within 5 seconds, turn off power to prevent motor damage. Motor requires more power than generator can supply.

Ref. ST-800 396-A / S-0625

10-10. Typical Connections To Supply Standby Power



☞ *Customer-supplied equipment is required if generator is to supply standby power during emergencies or power outages.*

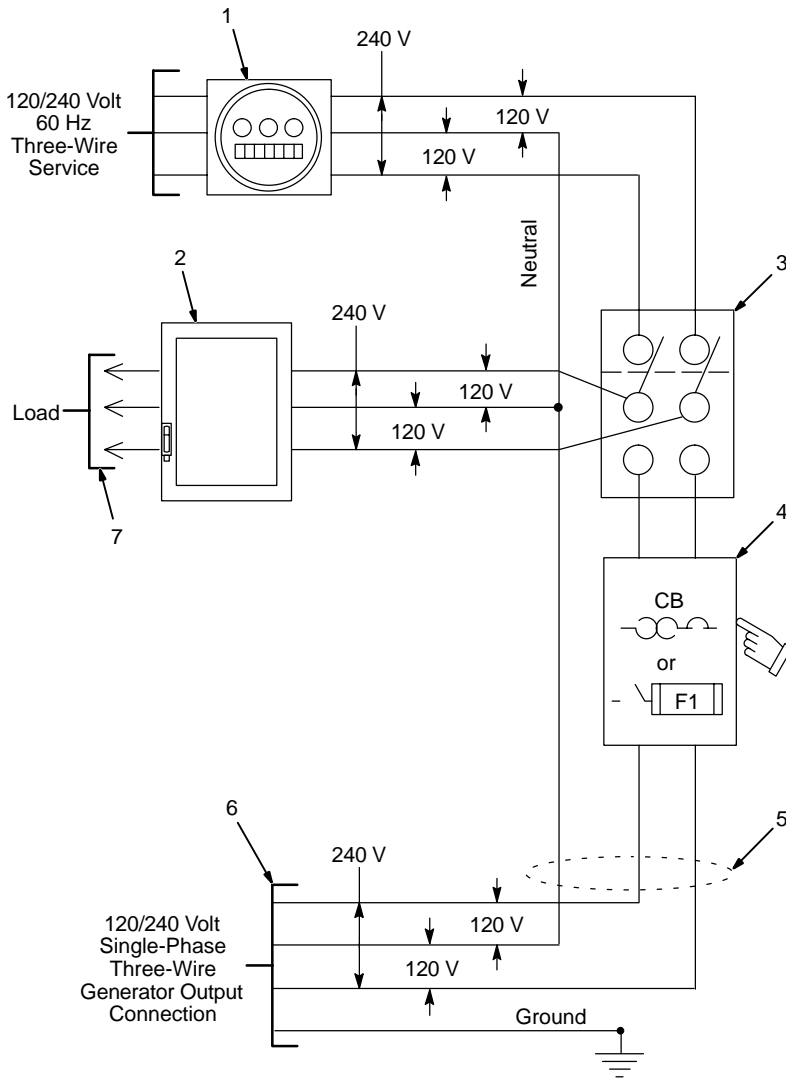

- 1 Power Company Service Meter
- 2 Main and Branch Overcurrent Protection
- 3 Double-Pole, Double-Throw Transfer Switch

Obtain and install correct switch. Switch rating must be same as or greater than the branch overcurrent protection.

- 4 Circuit Breakers or Fused Disconnect Switch

Obtain and install correct switch.

- 5 Extension Cord

Select as shown in Section 10-11.

- 6 Generator Connections

Connect terminals or plug of adequate amperage capacity to cord. Follow all applicable codes and safety practices.

Turn off or unplug all equipment connected to generator before starting or stopping engine. When starting or stopping, the engine has low speed which causes low voltage and frequency.

- 7 Load Connections

Item 4 is not necessary if circuit protection is already present in welding generator auxiliary power output circuit.

10-11. Selecting Extension Cord (Use Shortest Cord Possible)



| Cord Lengths for 120 Volt Loads | | | | | | | |
|--|--------------|---|-----------|-----------|----------|----------|----------|
| ▲ If unit does not have GFCI receptacles, use GFCI-protected extension cord. | | | | | | | |
| Current (Amperes) | Load (Watts) | Maximum Allowable Cord Length in ft (m) for Conductor Size (AWG)* | | | | | |
| | | 4 | 6 | 8 | 10 | 12 | 14 |
| 5 | 600 | | | 350 (106) | 225 (68) | 137 (42) | 100 (30) |
| 7 | 840 | | 400 (122) | 250 (76) | 150 (46) | 100 (30) | 62 (19) |
| 10 | 1200 | 400 (122) | 275 (84) | 175 (53) | 112 (34) | 62 (19) | 50 (15) |
| 15 | 1800 | 300 (91) | 175 (53) | 112 (34) | 75 (23) | 37 (11) | 30 (9) |
| 20 | 2400 | 225 (68) | 137 (42) | 87 (26) | 50 (15) | 30 (9) | |
| 25 | 3000 | 175 (53) | 112 (34) | 62 (19) | 37 (11) | | |
| 30 | 3600 | 150 (46) | 87 (26) | 50 (15) | 37 (11) | | |
| 35 | 4200 | 125 (38) | 75 (23) | 50 (15) | | | |
| 40 | 4800 | 112 (34) | 62 (19) | 37 (11) | | | |
| 45 | 5400 | 100 (30) | 62 (19) | | | | |
| 50 | 6000 | 87 (26) | 50 (15) | | | | |

*Conductor size is based on maximum 2% voltage drop

| Cord Lengths for 240 Volt Loads | | | | | | | |
|--|--------------|---|-----------|-----------|-----------|----------|----------|
| ▲ If unit does not have GFCI receptacles, use GFCI-protected extension cord. | | | | | | | |
| Current (Amperes) | Load (Watts) | Maximum Allowable Cord Length in ft (m) for Conductor Size (AWG)* | | | | | |
| | | 4 | 6 | 8 | 10 | 12 | 14 |
| 5 | 1200 | | | 700 (213) | 450 (137) | 225 (84) | 200 (61) |
| 7 | 1680 | | 800 (244) | 500 (152) | 300 (91) | 200 (61) | 125 (38) |
| 10 | 2400 | 800 (244) | 550 (168) | 350 (107) | 225 (69) | 125 (38) | 100 (31) |
| 15 | 3600 | 600 (183) | 350 (107) | 225 (69) | 150 (46) | 75 (23) | 60 (18) |
| 20 | 4800 | 450 (137) | 275 (84) | 175 (53) | 100 (31) | 60 (18) | |
| 25 | 6000 | 350 (107) | 225 (69) | 125 (38) | 75 (23) | | |
| 30 | 7000 | 300 (91) | 175 (53) | 100 (31) | 75 (23) | | |
| 35 | 8400 | 250 (76) | 150 (46) | 100 (31) | | | |
| 40 | 9600 | 225 (69) | 125 (38) | 75 (23) | | | |
| 45 | 10,800 | 200 (61) | 125 (38) | | | | |
| 50 | 12,000 | 175 (53) | 100 (31) | | | | |

*Conductor size is based on maximum 2% voltage drop

SECTION 11 – STICK WELDING (SMAW) GUIDELINES



11-1. Stick Welding Procedure

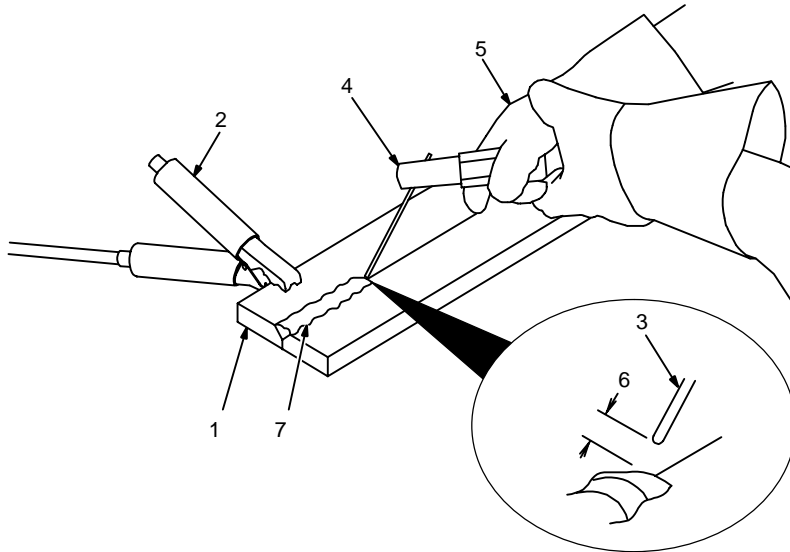

▲ Weld current starts when electrode touches workpiece.

▲ Weld current can damage electronic parts in vehicles. Disconnect both battery cables before welding on a vehicle. Place work clamp as close to the weld as possible.

1 Workpiece

Make sure workpiece is clean before welding.

2 Work Clamp

3 Electrode

A small diameter electrode requires less current than a large one. Follow electrode manufacturer's instructions when setting weld amperage (see Section 11-2).

4 Insulated Electrode Holder

5 Electrode Holder Position

6 Arc Length

Arc length is the distance from the electrode to the workpiece. A short arc with correct amperage will give a sharp, crackling sound.

7 Slag

Use a chipping hammer and wire brush to remove slag. Remove slag and check weld bead before making another weld pass.

Tools Needed:

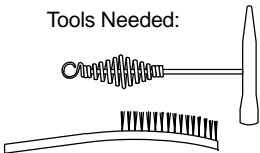

11-2. Electrode and Amperage Selection Chart

| ELECTRODE | DIAMETER | AMPERAGE RANGE | | | | | | | | |
|-------------|----------|----------------|-----|-----|-----|-----|-----|-----|-----|-----|
| | | 50 | 100 | 150 | 200 | 250 | 300 | 350 | 400 | 450 |
| 6010 & 6011 | 3/32 | | | | | | | | | |
| | 1/8 | | | | | | | | | |
| | 5/32 | | | | | | | | | |
| | 3/16 | | | | | | | | | |
| | 7/32 | | | | | | | | | |
| 6013 | 1/4 | | | | | | | | | |
| | 1/16 | | | | | | | | | |
| | 5/64 | | | | | | | | | |
| | 3/32 | | | | | | | | | |
| | 1/8 | | | | | | | | | |
| | 5/32 | | | | | | | | | |
| | 3/16 | | | | | | | | | |
| 7014 | 7/32 | | | | | | | | | |
| | 1/4 | | | | | | | | | |
| | 3/32 | | | | | | | | | |
| | 1/8 | | | | | | | | | |
| | 5/32 | | | | | | | | | |
| 7018 | 3/16 | | | | | | | | | |
| | 7/32 | | | | | | | | | |
| | 1/4 | | | | | | | | | |
| | 3/32 | | | | | | | | | |
| | 1/8 | | | | | | | | | |
| 7024 | 5/32 | | | | | | | | | |
| | 3/16 | | | | | | | | | |
| | 7/32 | | | | | | | | | |
| | 1/4 | | | | | | | | | |
| | 3/32 | | | | | | | | | |
| Ni-CI | 1/8 | | | | | | | | | |
| | 5/32 | | | | | | | | | |
| | 3/16 | | | | | | | | | |
| 308L | 3/32 | | | | | | | | | |
| | 1/8 | | | | | | | | | |
| | 5/32 | | | | | | | | | |

| ELECTRODE | DC* | AC | POSITION | PENETRATION | USAGE |
|-----------|-------|----|-------------------|-------------|----------------------|
| 6010 | EP | | ALL | DEEP | MIN. PREP, ROUGH |
| 6011 | EP | ✓ | ALL | DEEP | HIGH SPATTER |
| 6013 | EP,EN | ✓ | ALL | LOW | GENERAL |
| 7014 | EP,EN | ✓ | ALL | MED | SMOOTH, EASY, FAST |
| 7018 | EP | ✓ | ALL | LOW | LOW HYDROGEN, STRONG |
| 7024 | EP,EN | ✓ | FLAT HORIZ FILLET | LOW | SMOOTH, EASY, FASTER |
| NI-CL | EP | ✓ | ALL | LOW | CAST IRON |
| 308L | EP | ✓ | ALL | LOW | STAINLESS |

*EP = ELECTRODE POSITIVE (REVERSE POLARITY)
EN = ELECTRODE NEGATIVE (STRAIGHT POLARITY)

Ref. S-087 985-A

11-3. Striking an Arc – Scratch Start Technique

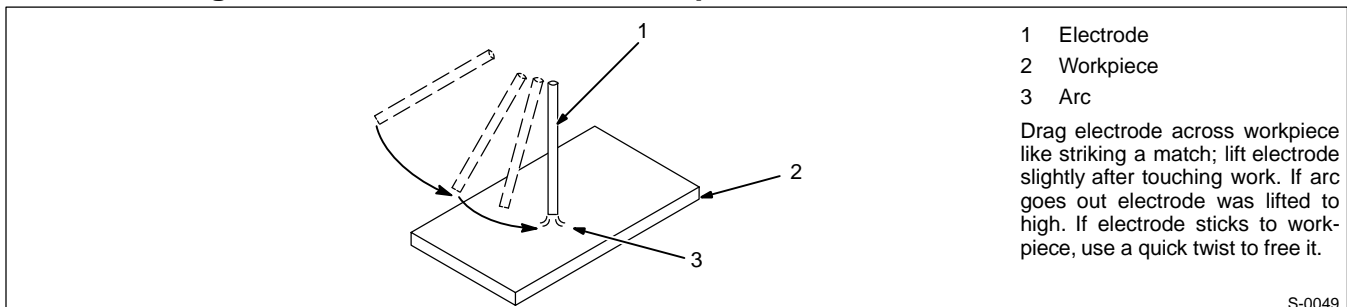

S-0049

11-4. Striking an Arc – Tapping Technique

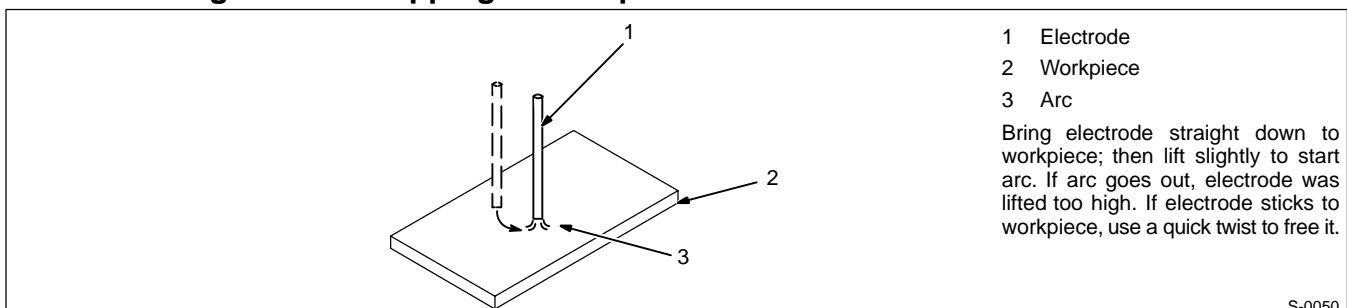

S-0050

11-5. Positioning Electrode Holder

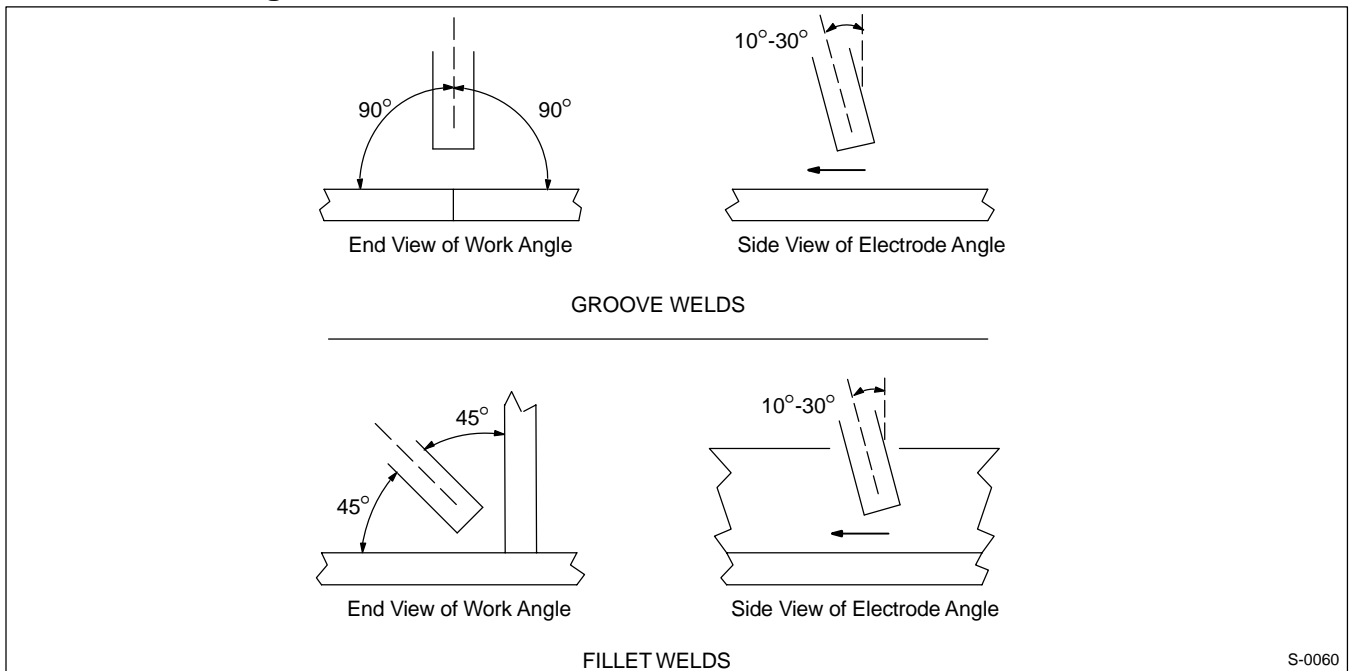

S-0060

11-6. Poor Weld Bead Characteristics

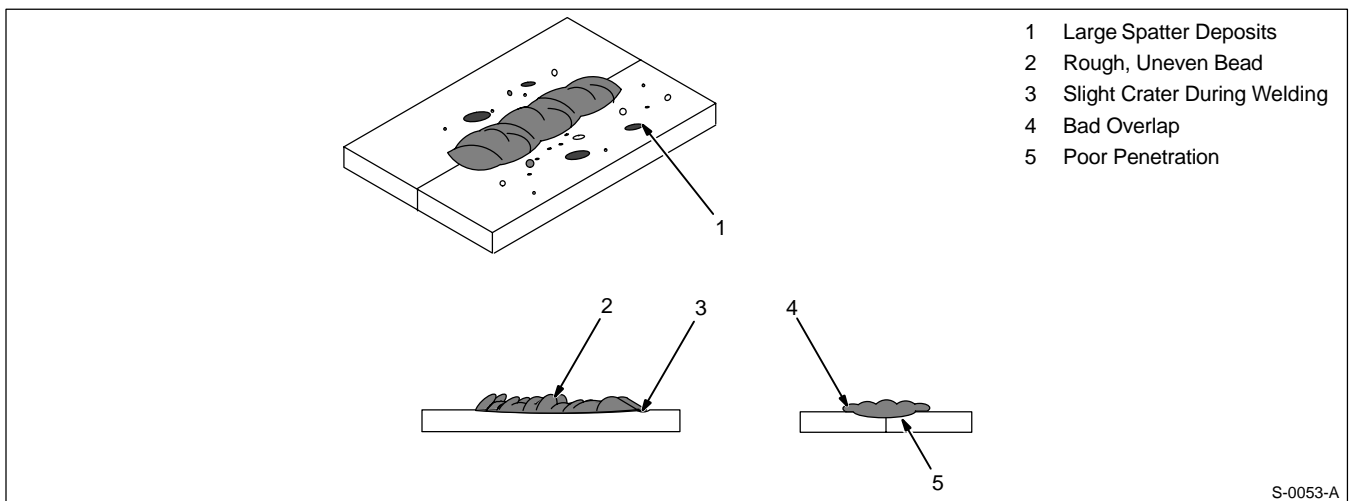

S-0053-A

11-7. Good Weld Bead Characteristics

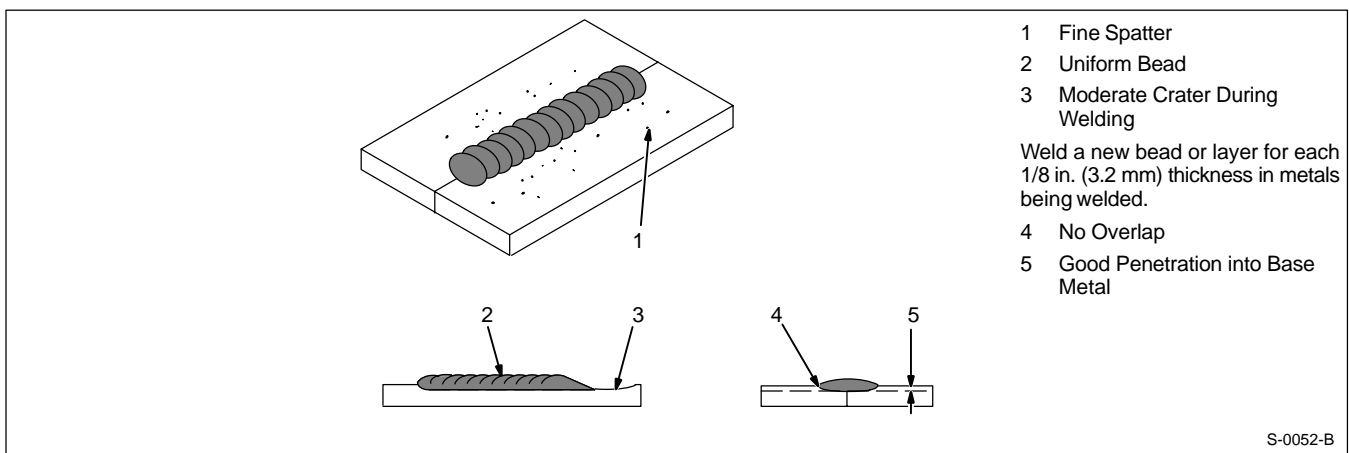

S-0052-B

11-8. Conditions That Affect Weld Bead Shape

NOTE

Weld bead shape is affected by electrode angle, arc length, travel speed, and thickness of base metal.

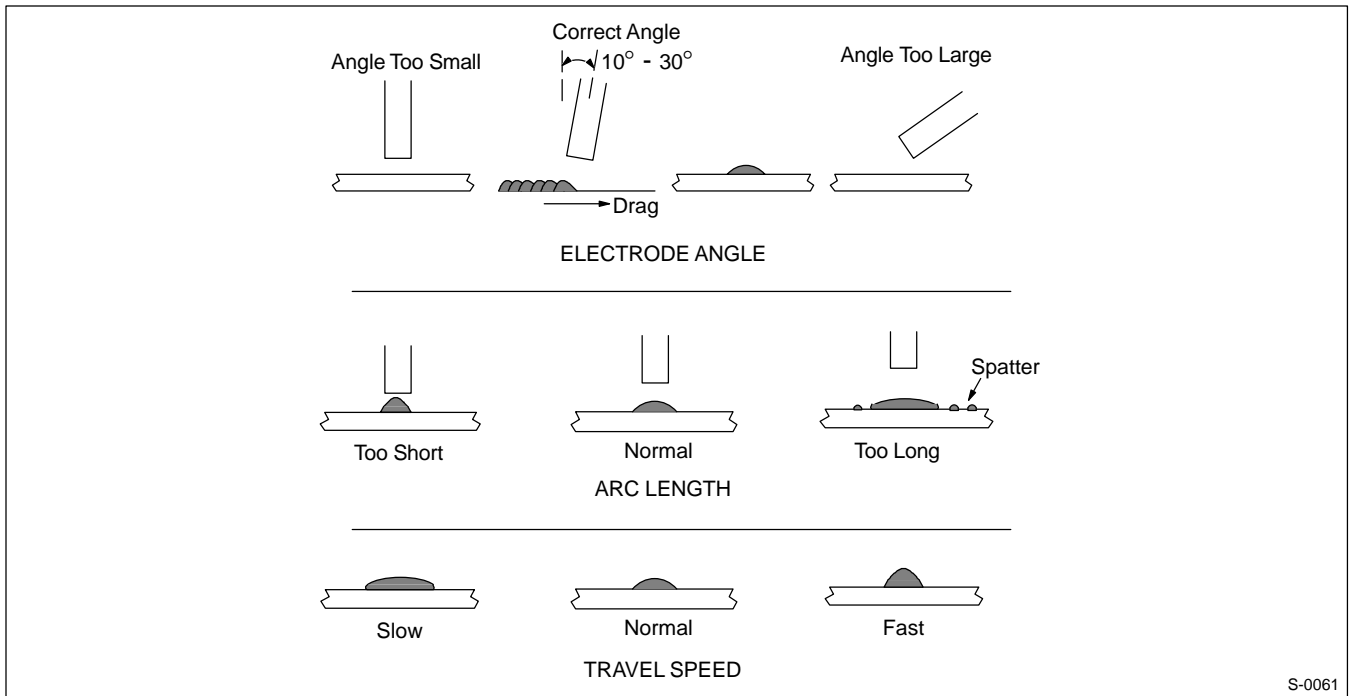

11-9. Electrode Movement During Welding

NOTE

Normally, a single stringer bead is satisfactory for most narrow groove weld joints; however, for wide groove weld joints or bridging across gaps, a weave bead or multiple stringer beads work better.

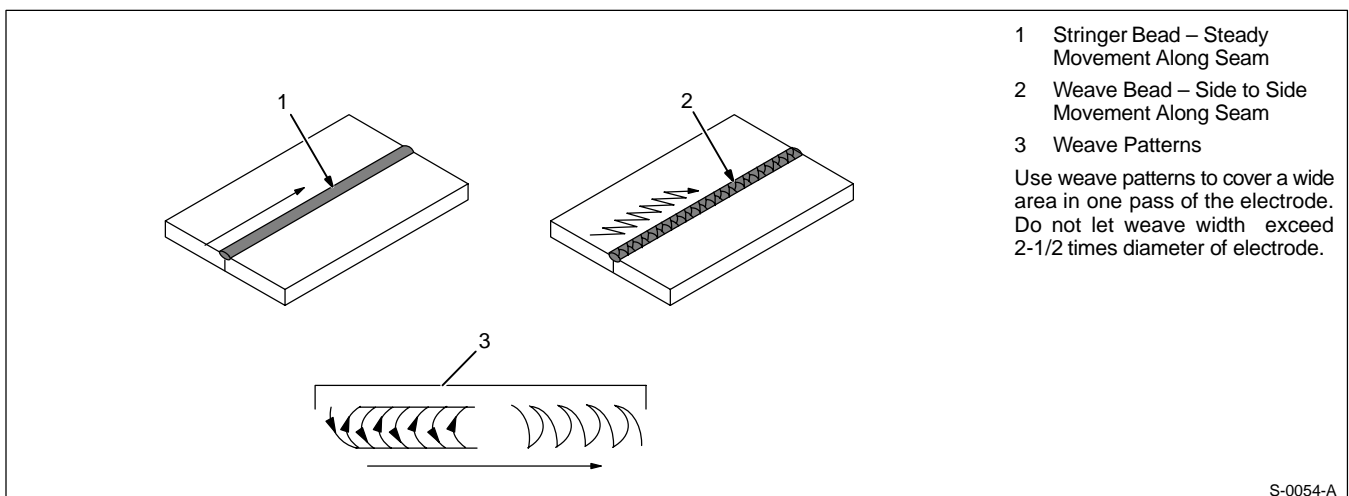

11-10. Butt Joints

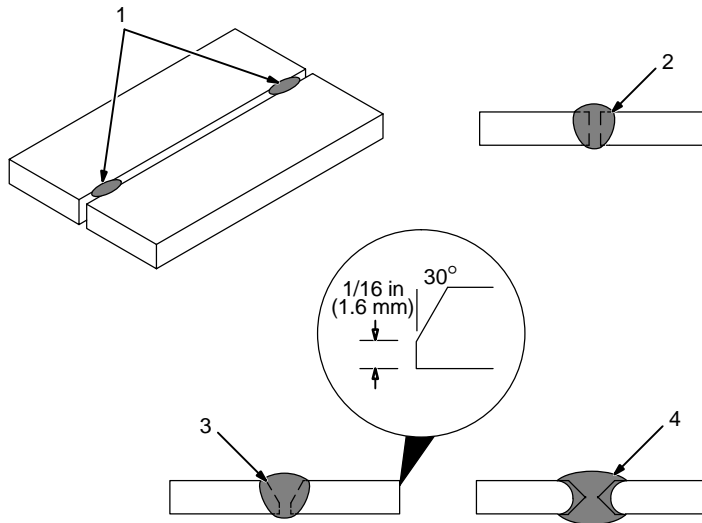

1 Tack Welds

Prevent edges of joint from drawing together ahead of electrode by tack welding the materials in position before final weld.

2 Square Groove Weld

Good for materials up to 3/16 in (5 mm) thick.

3 Single V-Groove Weld

Good for materials 3/16 – 3/4 in (5-19 mm) thick. Cut bevel with oxy-acetylene or plasma cutting equipment. Remove scale from material after cutting. A grinder can also be used to prepare bevels.

Create 30 degree angle of bevel on materials in V-groove welding.

4 Double V-Groove Weld

Good for materials thicker than 3/16 in (5 mm).

S-0662

11-11. Lap Joint

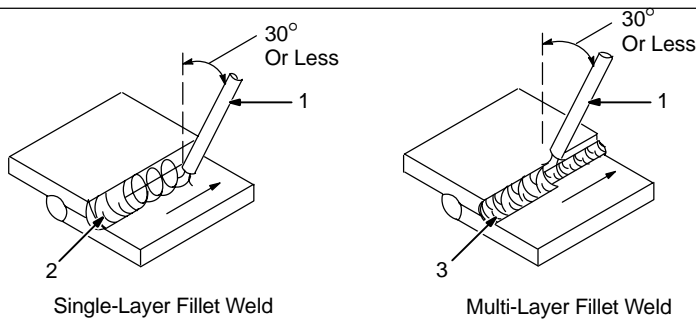

1 Electrode

2 Single-Layer Fillet Weld

Move electrode in circular motion.

3 Multi-Layer Fillet Weld

Weld a second layer when a heavier fillet is needed. Remove slag before making another weld pass. Weld both sides of joint for maximum strength.

S-0063 / S-0064

11-12. Tee Joint

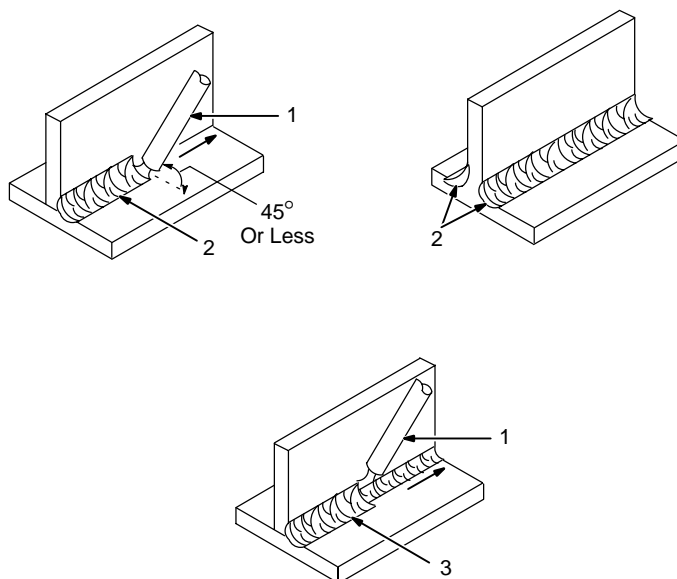

1 Electrode

2 Fillet Weld

Keep arc short and move at definite rate of speed. Hold electrode as shown to provide fusion into the corner. Square edge of the weld surface.

For maximum strength weld both sides of upright section.

3 Multi-Layer Deposits

Weld a second layer when a heavier fillet is needed. Use any of the weaving patterns shown in Section 11-9. Remove slag before making another weld pass.

S-0060 / S-0058-A / S-0061

11-13. Weld Test

1 Vise
2 Weld Joint
3 Hammer

Strike weld joint in direction shown. A good weld bends over but does not break.

S-0057-B

11-14. Troubleshooting – Porosity

Porosity – small cavities or holes resulting from gas pockets in weld metal.

| Possible Causes | Corrective Actions |
|----------------------|---|
| Arc length too long. | Reduce arc length. |
| Damp electrode. | Use dry electrode. |
| Workpiece dirty. | Remove all grease, oil, moisture, rust, paint, coatings, slag, and dirt from work surface before welding. |

11-15. Troubleshooting – Excessive Spatter

Excessive Spatter – scattering of molten metal particles that cool to solid form near weld bead.

| Possible Causes | Corrective Actions |
|--|---|
| Amperage too high for electrode. | Decrease amperage or select larger electrode. |
| Arc length too long or voltage too high. | Reduce arc length or voltage. |

11-16. Troubleshooting – Incomplete Fusion

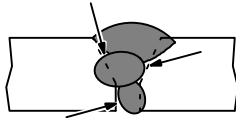
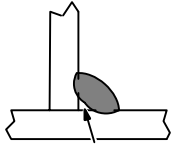

Incomplete Fusion – failure of weld metal to fuse completely with base metal or a preceding weld bead.

| Possible Causes | Corrective Actions |
|-----------------------------|---|
| Insufficient heat input. | Increase amperage. Select larger electrode and increase amperage. |
| Improper welding technique. | Place stringer bead in proper location(s) at joint during welding. |
| | Adjust work angle or widen groove to access bottom during welding. |
| | Momentarily hold arc on groove side walls when using weaving technique. |
| | Keep arc on leading edge of weld puddle. |
| Workpiece dirty. | Remove all grease, oil, moisture, rust, paint, coatings, slag, and dirt from work surface before welding. |

11-17. Troubleshooting – Lack Of Penetration

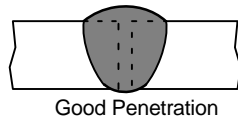
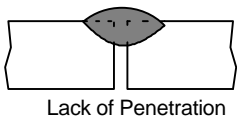

Lack Of Penetration – shallow fusion between weld metal and base metal.

| Possible Causes | Corrective Actions |
|-----------------------------|---|
| Improper joint preparation. | Material too thick. Joint preparation and design must provide access to bottom of groove. |
| Improper weld technique. | Keep arc on leading edge of weld puddle. |
| Insufficient heat input. | Increase amperage. Select larger electrode and increase amperage. |
| | Reduce travel speed. |

11-18. Troubleshooting – Excessive Penetration

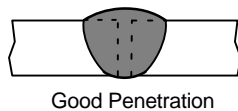
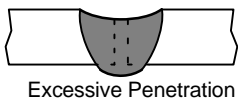

Excessive Penetration – weld metal melting through base metal and hanging underneath weld.

| Possible Causes | Corrective Actions |
|-----------------------|---|
| Excessive heat input. | Select lower amperage. Use smaller electrode. |
| | Increase and/or maintain steady travel speed. |

11-19. Troubleshooting – Burn-Through

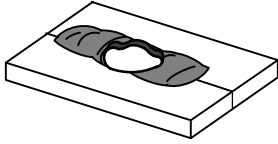

Burn-Through – weld metal melting completely through base metal resulting in holes where no metal remains.

| Possible Causes | Corrective Actions |
|-----------------------|---|
| Excessive heat input. | Select lower amperage. Use smaller electrode. |
| | Increase and/or maintain steady travel speed. |

11-20. Troubleshooting – Waviness Of Bead

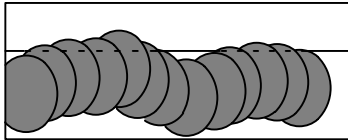

Waviness Of Bead – weld metal that is not parallel and does not cover joint formed by base metal.

| Possible Causes | Corrective Actions |
|-----------------|------------------------------------|
| Unsteady hand. | Use two hands. Practice technique. |

11-21. Troubleshooting – Distortion

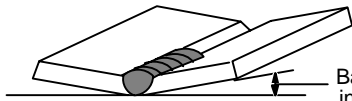

Base metal moves in the direction of the weld bead.

Distortion – contraction of weld metal during welding that forces base metal to move.

| Possible Causes | Corrective Actions |
|-----------------------|--|
| Excessive heat input. | Use restraint (clamp) to hold base metal in position. |
| | Make tack welds along joint before starting welding operation. |
| | Select lower amperage for electrode. |
| | Increase travel speed. |
| | Weld in small segments and allow cooling between welds. |

SECTION 12 – PARTS LIST

 Hardware is common and not available unless listed.

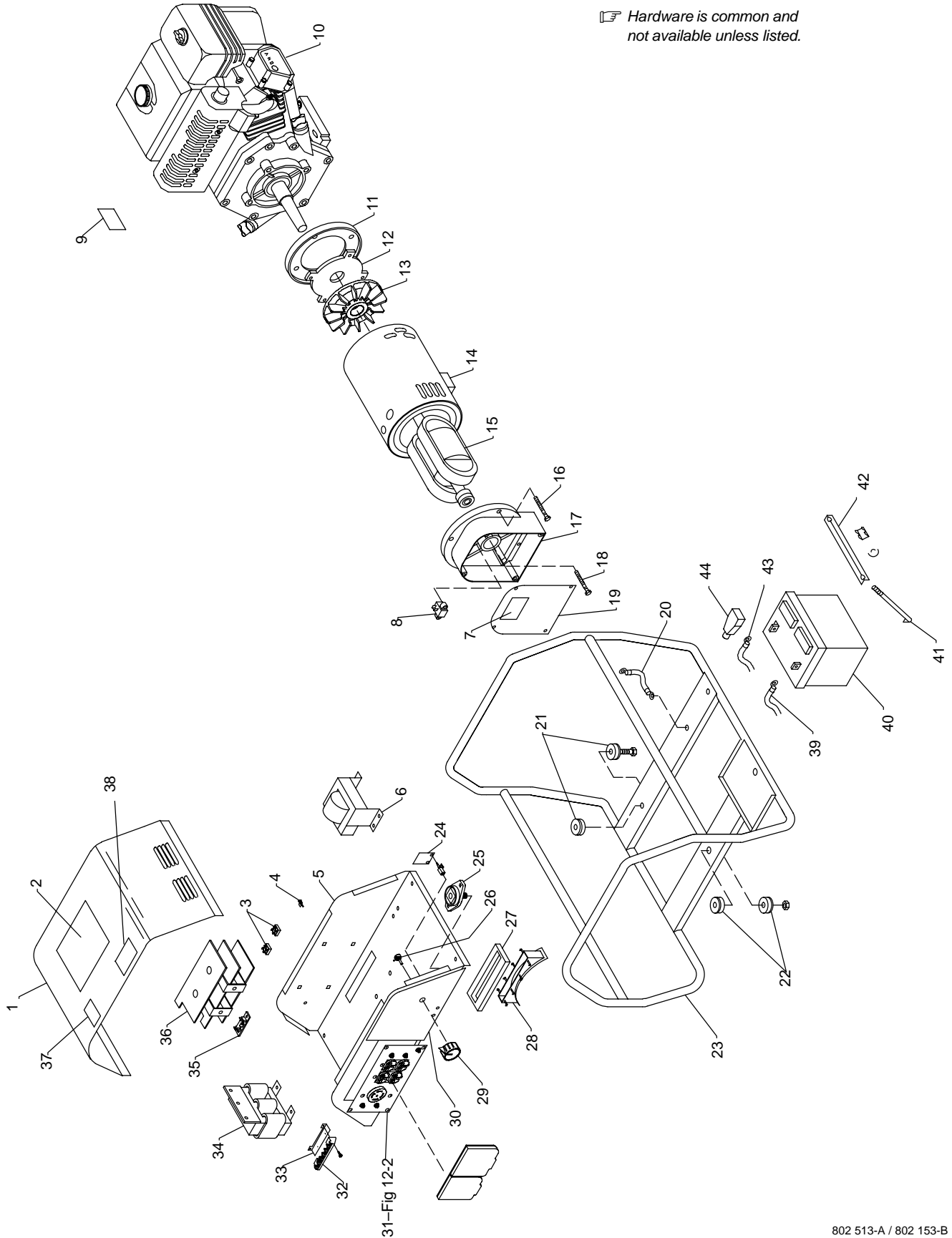

Figure 12-1. Main Assembly

802 513-A / 802 153-B

| Item No. | Dia. Mkgs. | Part No. | Description | Quantity |
|----------|------------|----------|-------------|----------|
|----------|------------|----------|-------------|----------|

Figure 12-1. Main Assembly

| | | | | |
|----|----------|-------------|---|---|
| 1 | | +495 247 | TOP, control box (specify color) | 1 |
| 2 | | 495 096 | LABEL, precautionary | 1 |
| 3 | CR1, CR2 | 200 759 | RECTIFIER, silicon | 2 |
| 4 | | 134 201 | STAND-OFF, support | 4 |
| 5 | | 495 236 | BASE, control box | 1 |
| 6 | L3 | 495 200 | REACTOR, stabilizing | 1 |
| 7 | | 204 140 | LABEL, moving parts | 1 |
| 8 | | 493 509 | BRUSHHOLDER, assembly | 1 |
| 9 | | 204 138 | LABEL, warning fuel (also supplied with engine) | 1 |
| 10 | | +195 557 | ENGINE, gas Kohler 8.5HP (recoil start) | 1 |
| | | *203 952 | FILTER, air Kohler cs 8.5 & 12 | 1 |
| | | *203 954 | FILTER, air pre Kohler cs 8.5 & 12 | 1 |
| | | *203 955 | CAP, fuel Kohler cs 8.5 & 12 | 1 |
| | | *203 956 | TANK, fuel Kohler cs 8.5 & 12 | 1 |
| | | *203 957 | STRAINER, fuel Kohler cs 8.5 & 12 | 1 |
| | | *203 958 | MUFFLER, exhaust engine Kohler cs 8.5 & 12 | 1 |
| | | *203 959 | GASKET, muffler Kohler cs 8.5 & 12 | 1 |
| | | *203 960 | SPARK PLUG, Kohler cs 8.5 & 12 | 1 |
| 10 | | +184 556 | ENGINE, Honda 9HP (recoil start) | 1 |
| 10 | | +184 555 | ENGINE, Honda 9HP (electric start) | 1 |
| 11 | | 494 606 | ADAPTER, engine | 1 |
| 12 | | 494 629 | GUARD, generator | 1 |
| 13 | | 194 509 | FAN, generator (Kohler) | 1 |
| 13 | | 493 868 | FAN, generator (Honda) | 1 |
| 14 | | 495 213 | GENERATOR, w/stator assembly | 1 |
| 15 | L1-D | 494 574 | ROTOR, assembly | 1 |
| 16 | | 495 349 | SCREW, 1/4-20 HWH | 4 |
| 17 | | 494 587 | CARRIER, bearing | 1 |
| 18 | | 495 348 | SCREW, 5/16-24 HWH | 1 |
| 19 | | +494 628 | PANEL, end generator | 1 |
| 20 | | 495 113 | LEAD, bonding | 1 |
| 21 | | 495 257 | MOUNT, shock w/bushing | 2 |
| 22 | | 495 256 | MOUNT, shock generator | 1 |
| 23 | | 194 504 | FRAME, mtg assembly (Kohler) | 1 |
| 23 | | 495 132 | FRAME, mtg assembly (Honda) | 1 |
| 24 | PC1 | 148 608 | BOARD, PC filter (CSA only) | 1 |
| 25 | | 494 613 | TERMINAL, output | 2 |
| 26 | R1 | 494 618 | RHEOSTAT, 35 ohm 100W | 1 |
| 27 | | 495 214 | SEAL, air duct | 1 |
| 28 | | 495 255 | DUCT, air | 1 |
| 29 | | 097 924 | KNOB, pointer | 1 |
| 30 | | | NAMEPLATE, overlay (order by model and serial number) | 1 |
| 31 | | Figure 12-2 | PANEL, aux power assembly (CSA) | 1 |
| 32 | 1T | 172 661 | BLOCK, terminal | 1 |
| 33 | | 495 193 | BRACKET, mtg terminal block | 1 |
| 34 | L2 | 495 202 | REACTOR, weld assembly | 1 |
| 35 | R2/VR1 | 046 819 | SUPPRESSOR, assembly | 1 |
| 36 | CR3 | 495 188 | RECTIFIER, assembly | 1 |
| 37 | | 201 223 | LABEL, warning electric shock power still present | 1 |
| 38 | | 494 976 | LABEL, current selection | 1 |
| 39 | | 495 112 | LEAD, battery neg (electric start) | 1 |
| 40 | | | BATTERY, 12V (electric start) | 1 |
| 41 | | 494 604 | BOLT, hold down (electric start) | 1 |
| 42 | | 493 057 | CLAMP, battery (electric start) | 1 |
| 43 | | 495 111 | LEAD, battery pos (electric start) | 1 |
| 44 | | 494 039 | COVER, battery cable (electric start) | 1 |

+When ordering a part displaying a precautionary label, order label also. *Recommended Spare Parts.

To maintain the factory original performance of your equipment, use only Manufacturer's Suggested Replacement Parts. Model and serial number required when ordering parts from your local distributor.

Hardware is common and not available unless listed.

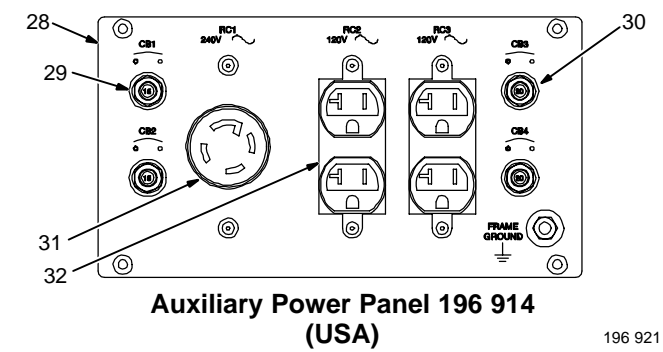
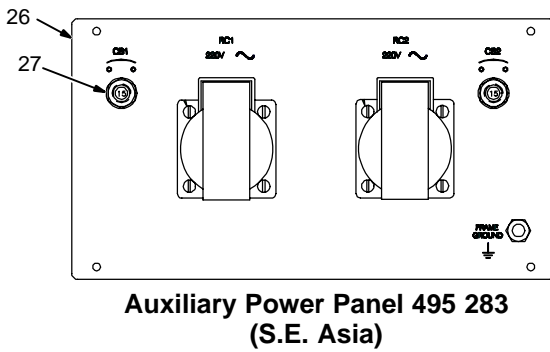
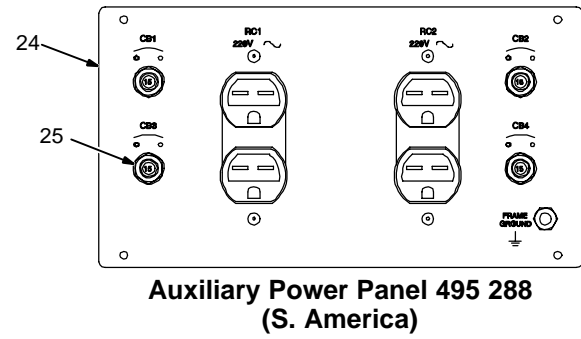
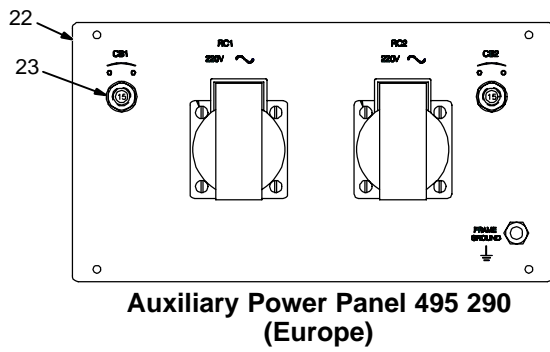
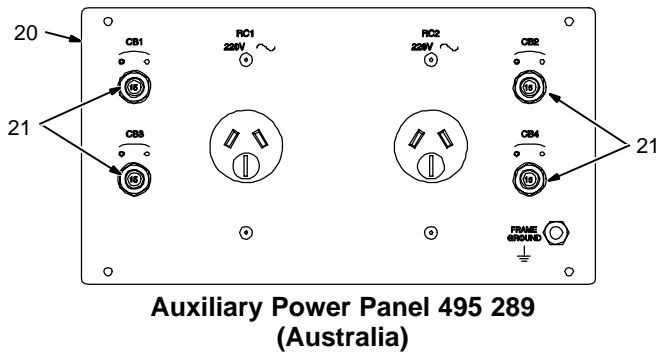
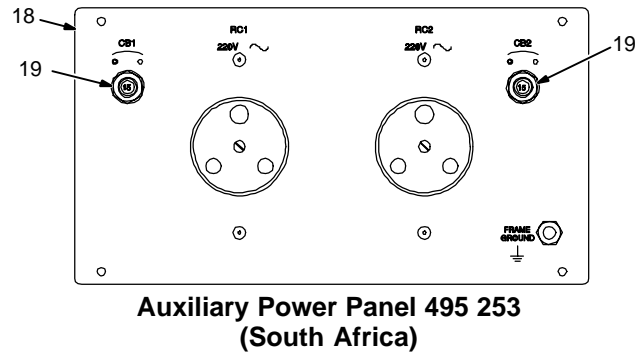
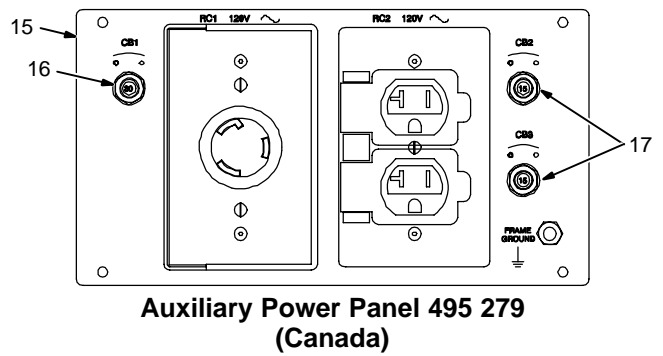
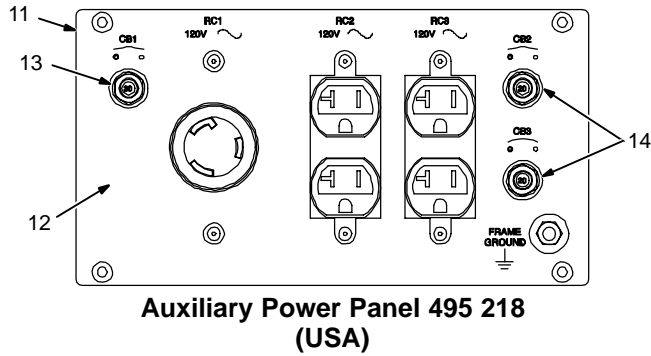
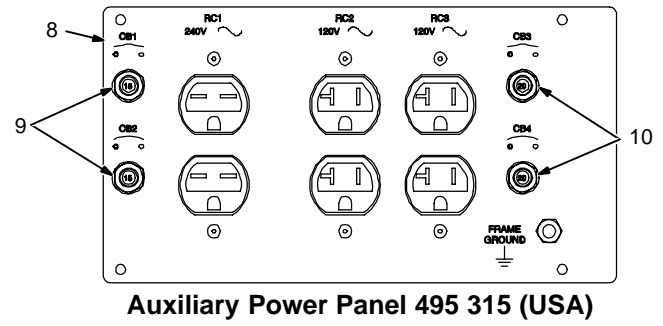
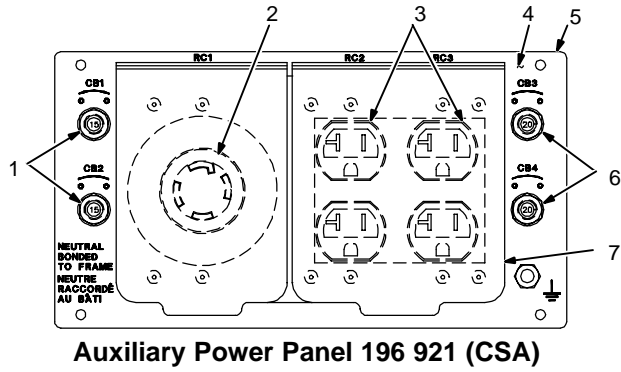

Figure 12-2. Auxiliary Power Panels

| Item No. | Dia. Mkgs. | Part No. | Description | Quantity |
|----------|------------|----------|-------------|----------|
|----------|------------|----------|-------------|----------|

Figure 12-2. Auxiliary Power Panels (Figure 12-1, Item 31)

Auxiliary Power Panel 196 921 (CSA)

| | | | | |
|-------|-------------|--------------|-------------------------------------|---|
| ... 1 | .. CB1, CB2 | ... 495 245 | .. Circuit Breaker, 15A | 2 |
| ... 2 | RC1 | 407 749 | .. Receptacle, Twistlock 240V U.S. | 1 |
| ... 3 | .. RC2, RC3 | ... 408 898 | .. Receptacle, Duplex 115V 20A U.S. | 2 |
| ... 4 | | 196 909 | .. Label, 120/240V Aux Power Panel | 1 |
| ... 5 | | 196 911 | .. Panel, 120/240V Aux Power | 1 |
| ... 6 | .. CB3, CB4 | ... 495 246 | .. Circuit Breaker, 20A | 2 |
| ... 7 | | 188 039 | .. Cover, Receptacle W/Gasket | 1 |

Auxiliary Power Panel 495 315

| | | | | |
|--------|-------------|-------------|------------------------------------|---|
| ... 8 | | 495 314 | .. Panel, auxiliary power assembly | 1 |
| ... 9 | .. CB1, CB2 | ... 495 245 | .. Circuit Breaker, 15A | 2 |
| ... 10 | .. CB3, CB4 | ... 495 246 | .. Circuit Breaker, 20A | 2 |

Auxiliary Power Panel 495 218

| | | | | |
|--------|-------------|--------------|------------------------------------|---|
| ... 11 | | 495 220 | .. Panel, auxiliary power assembly | 1 |
| ... 12 | | 495 216 | .. Overlay | 1 |
| ... 13 | CB1 | 495 183 | .. Circuit Breaker, 30A | 1 |
| ... 14 | .. CB2, CB3 | ... 495 246 | .. Circuit Breaker, 20A | 2 |

Auxiliary Power Panel 495 279 (Canada)

| | | | | |
|--------|-------------|--------------|------------------------------------|---|
| ... 15 | | 495 284 | .. Panel, auxiliary power assembly | 1 |
| ... 16 | CB1 | 495 183 | .. Circuit Breaker, 30A | 1 |
| ... 17 | .. CB2, CB3 | ... 495 246 | .. Circuit Breaker, 20A | 2 |

Auxiliary Power Panel 495 253 (South Africa)

| | | | | |
|--------|-------------|-------------|------------------------------------|---|
| ... 18 | | 495 252 | .. Panel, auxiliary power assembly | 1 |
| ... 19 | .. CB1, CB2 | ... 495 245 | .. Circuit Breaker, 15A | 2 |

Auxiliary Power Panel 495 289 (Australia)

| | | | | |
|--------|--------------|-------------|------------------------------------|---|
| ... 20 | | 495 254 | .. Panel, auxiliary power assembly | 1 |
| ... 21 | .. CB1 - CB4 | ... 495 245 | .. Circuit Breaker, 15A | 4 |

Auxiliary Power Panel 495 290 (Europe)

| | | | | |
|--------|-------------|-------------|------------------------------------|---|
| ... 22 | | 495 282 | .. PANEL, auxiliary power assembly | 1 |
| ... 23 | .. CB1, CB2 | ... 495 245 | .. CIRCUIT BREAKER, 15A | 2 |

Auxiliary Power Panel 495 288 (S. America)

| | | | | |
|--------|------------|--------------|------------------------------------|---|
| ... 24 | | 495 287 | .. PANEL, auxiliary power assembly | 1 |
| ... 25 | CB1-4 | 495 245 | .. CIRCUIT BREAKER, 15A | 4 |

Auxiliary Power Panel 495 283 (S.E. Asia)

| | | | | |
|--------|-------------|-------------|------------------------------------|---|
| ... 26 | | 495 282 | .. PANEL, auxiliary power assembly | 1 |
| ... 27 | .. CB1, CB2 | ... 495 245 | .. CIRCUIT BREAKER, 15A | 2 |

Auxiliary Power Panel 196 914 (USA)

| | | | | |
|--------|-------------|--------------|--|---|
| ... 28 | | 495 220 | .. PANEL, auxiliary power assembly | 1 |
| ... 29 | .. CB1, CB2 | ... 495 245 | .. CIRCUIT BREAKER, 15A | 2 |
| ... 30 | .. CB3, CB4 | ... 495 246 | .. CIRCUIT BREAKER, 20A | 2 |
| ... 31 | RC1 | 129 067 | .. RECEPTACLE, tw lk grd 3P4W 30A 125/250V | 1 |
| ... 32 | | 088 898 | .. PLUG, tw lk grd 3P4W 30A 125/250V | 1 |
| ... 32 | .. RC2, RC3 | ... 141 432 | .. RECEPTACLE, str dx grd 2P3W 20A 125V | 2 |
| ... 32 | | 073 690 | .. PLUG, str grd armd 2P3W 15A 125V | 2 |

*Recommended Spare Parts.

NOTE: Replacement receptacles not listed can be found at your local hardware or electrical supply store.

To maintain the factory original performance of your equipment, use only Manufacturer's Suggested Replacement Parts. Model and serial number required when ordering parts from your local distributor.

HOBART 5/3/1 WARRANTY

Effective October 1, 1999

Warranty Questions?

Call
1-877-HOBART1
for your local
Hobart distributor.

Service

You always get the fast, reliable response you need. Most replacement parts can be in your hands in 24 hours.

Support

Need fast answers to the tough welding questions? Contact your distributor or call 1-800-332-3281. The expertise of the distributor and Hobart is there to help you, every step of the way.

5/3/1 WARRANTY applies to all Handler 135 and 175 models, Airforce 250, 250A, and 375 models, and Champion 10,000 models. This warranty also applies to the Beta-Mig 1800, Champ 1435, 2060, 8500 models, Ironman 250, Stickmate models, Tigmate models, and HSW-15 and HSW-25 spot welder models effective with Serial No. KK200262 and newer.

This limited warranty supersedes all previous Hobart warranties and is exclusive with no other guarantees or warranties expressed or implied.

Hobart products are serviced by Hobart or Miller Authorized Service Agencies.

LIMITED WARRANTY – Subject to the terms and conditions below, Hobart/Miller Electric Mfg. Co., Appleton, Wisconsin, warrants to its original retail purchaser that new Hobart equipment sold after the effective date of this limited warranty is free of defects in material and workmanship at the time it is shipped by Hobart. THIS WARRANTY IS EXPRESSLY IN LIEU OF ALL OTHER WARRANTIES, EXPRESS OR IMPLIED, INCLUDING THE WARRANTIES OF MERCHANTABILITY AND FITNESS.

Within the warranty periods listed below, Hobart/Miller will repair or replace any warranted parts or components that fail due to such defects in material or workmanship. Hobart/Miller must be notified in writing within thirty (30) days of such defect or failure, at which time Hobart/Miller will provide instructions on the warranty claim procedures to be followed.

Hobart/Miller shall honor warranty claims on warranted equipment listed below in the event of such a failure within the warranty time periods. All warranty time periods start on the date that the equipment was delivered to the original retail purchaser, or one year after the equipment is sent to a North American distributor or eighteen months after the equipment is sent to an International distributor.

1. 5 Years — Parts and Labor
 - * Original Main Power Rectifiers
 - * Transformers
 - * Stabilizers
 - * Reactors
 - * Rotors, Stators and Brushes
2. 3 Years — Parts and Labor
 - * Drive Systems
 - * PC Boards
 - * Idle Module
 - * Solenoid Valves
 - * Switches and Controls
 - * Spot Welder Transformer
3. 1 Year — Parts and Labor (90 days for industrial use)
 - * Motor-Driven Guns
 - * MIG Guns/TIG Torches
 - * Relays
 - * Contactors
 - * Regulators
 - * Water Coolant Systems
 - * HF Units
 - * Running Gear/Trailers
 - * Plasma Cutting Torches
 - * Remote Controls
 - * Replacement Parts (No labor)
 - * Accessories
 - * Field Options

(NOTE: Field options are covered for the remaining warranty period of the product they are installed in, or for a minimum of one year — whichever is greater.)

4. Engines, batteries and tires are warranted separately by the manufacturer.

Hobart's 5/3/1 Limited Warranty shall not apply to:

1. **Consumable components such as contact tips, cutting nozzles, slip rings, drive rolls, gas diffusers, plasma torch tips and electrodes, weld cables, and tongs and tips, or parts that fail due to normal wear.**
2. Items furnished by Hobart/Miller, but manufactured by others, such as engines or trade accessories. These items are covered by the manufacturer's warranty, if any.
3. Equipment that has been modified by any party other than Hobart/Miller, or equipment that has been improperly installed, improperly operated or misused based upon industry standards, or equipment which has not had reasonable and necessary maintenance, or equipment which has been used for operation outside of the specifications for the equipment.

HOBART PRODUCTS ARE INTENDED FOR PURCHASE AND USE BY COMMERCIAL/INDUSTRIAL USERS AND PERSONS TRAINED AND EXPERIENCED IN THE USE AND MAINTENANCE OF WELDING EQUIPMENT.

In the event of a warranty claim covered by this warranty, the exclusive remedies shall be, at Hobart's/Miller's option: (1) repair; or (2) replacement; or, where authorized in writing by Hobart/Miller in appropriate cases, (3) the reasonable cost of repair or replacement at an authorized Hobart/Miller service station; or (4) payment of or credit for the purchase price (less reasonable depreciation based upon actual use) upon return of the goods at customer's risk and expense. Hobart's/Miller's option of repair or replacement will be F.O.B., Factory at Appleton, Wisconsin, or F.O.B. at a Hobart/Miller authorized service facility as determined by Hobart/Miller. Therefore no compensation or reimbursement for transportation costs of any kind will be allowed.

TO THE EXTENT PERMITTED BY LAW, THE REMEDIES PROVIDED HEREIN ARE THE SOLE AND EXCLUSIVE REMEDIES. IN NO EVENT SHALL HOBART/MILLER BE LIABLE FOR DIRECT, INDIRECT, SPECIAL, INCIDENTAL OR CONSEQUENTIAL DAMAGES (INCLUDING LOSS OF PROFIT), WHETHER BASED ON CONTRACT, TORT OR ANY OTHER LEGAL THEORY.

ANY EXPRESS WARRANTY NOT PROVIDED HEREIN AND ANY IMPLIED WARRANTY, GUARANTY OR REPRESENTATION AS TO PERFORMANCE, AND ANY REMEDY FOR BREACH OF CONTRACT TORT OR ANY OTHER LEGAL THEORY WHICH, BUT FOR THIS PROVISION, MIGHT ARISE BY IMPLICATION, OPERATION OF LAW, CUSTOM OF TRADE OR COURSE OF DEALING, INCLUDING ANY IMPLIED WARRANTY OF MERCHANTABILITY OR FITNESS FOR PARTICULAR PURPOSE, WITH RESPECT TO ANY AND ALL EQUIPMENT FURNISHED BY HOBART/MILLER IS EXCLUDED AND DISCLAIMED BY Hobart/Miller.

Some states in the U.S.A. do not allow limitations of how long an implied warranty lasts, or the exclusion of incidental, indirect, special or consequential damages, so the above limitation or exclusion may not apply to you. This warranty provides specific legal rights, and other rights may be available, but may vary from state to state.

In Canada, legislation in some provinces provides for certain additional warranties or remedies other than as stated herein, and to the extent that they may not be waived, the limitations and exclusions set out above may not apply. This Limited Warranty provides specific legal rights, and other rights may be available, but may vary from province to province.





Owner's Record

Please complete and retain with your personal records.

Model Name

Serial/Style Number

Purchase Date

(Date which equipment was delivered to original customer.)

Distributor

Address

City

State

Zip



Resources Available

Always provide Model Name and Serial/Style Number.

To locate a Distributor, retail or service location:

Call 1-877-Hobart1 or visit our website at www.HobartWelders.com

For technical assistance:

Call 1-800-332-3281

Contact your Distributor for:

Welding Supplies and Consumables

Options and Accessories

Personal Safety Equipment

Service and Repair

Replacement Parts

Training (Schools, Videos, Books)

Technical Manuals (Servicing Information and Parts)

Circuit Diagrams

Welding Process Handbooks

Contact the Delivering Carrier for:

For assistance in filing or settling claims, contact your distributor and/or equipment manufacturer's Transportation Department.

File a claim for loss or damage during shipment.

Hobart Welding Products

An Illinois Tool Works Company
600 West Main Street
Troy, OH 45373 USA

For Technical Assistance:

Call 1-800-332-3281

For Literature Or Nearest Dealer:
Call 1-877-Hobart1