

RIDGID
18V Brad Nailer
Model No. R09890
Repair Sheet

RIDGID
Cloueuse à parquet 18 V
No. de modèle R09890
Feuille de réparation

RIDGID
Clavadora de puntillas de 18 V
Modelo R09890
Listas de piezas de repuesto

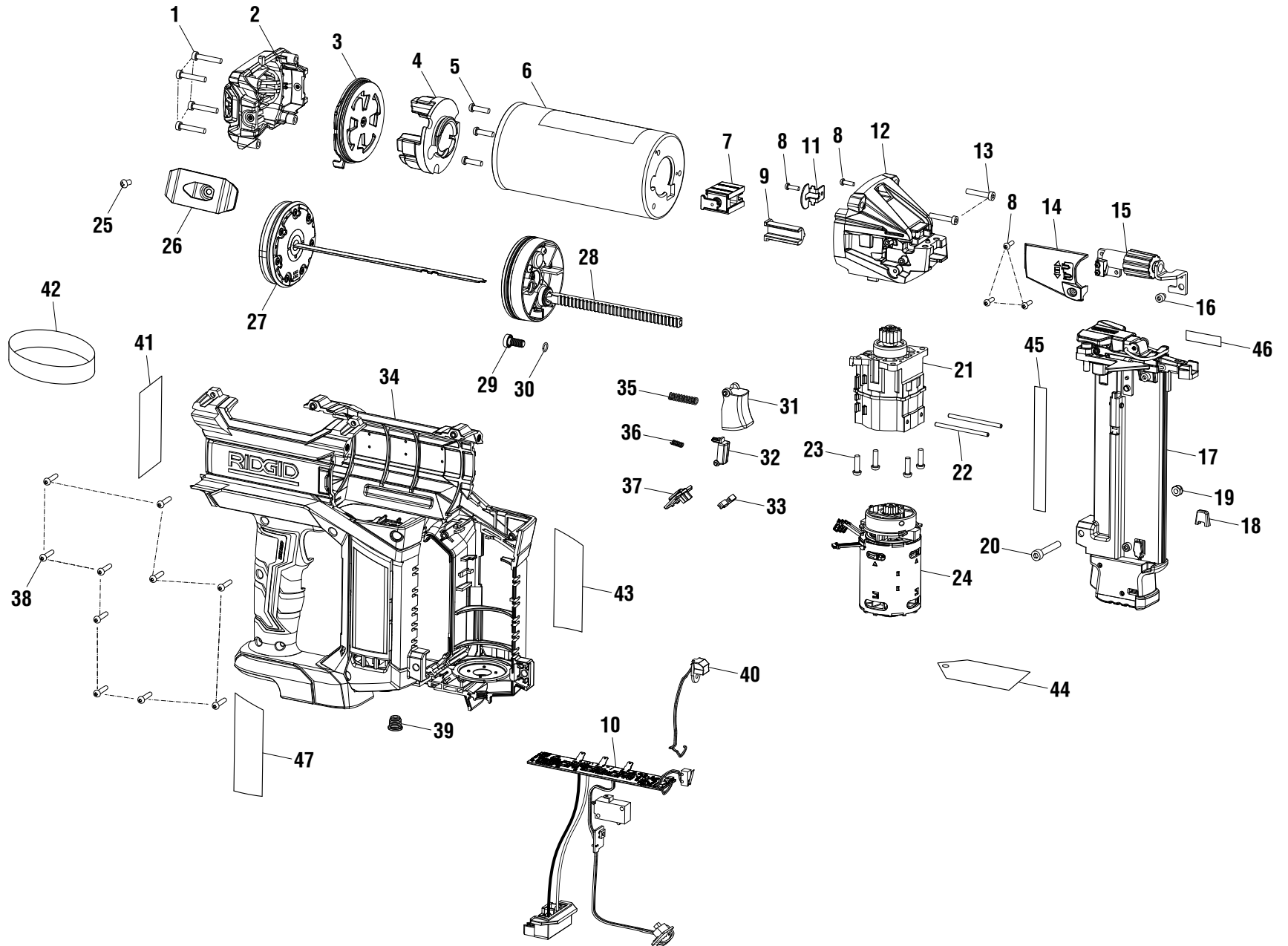



R09890

KEY NO.	PART NUMBER	DESCRIPTION	QTY
1	662225001	Screw (M4 x 22 mm).....	4
2	352131001	End Cap.....	1
3	203663001	Filter Shutter Assembly (Inc. Key No. 1).....	1
4	563577001	Bumper.....	1
5	661923001	Screw (M4 x 15 mm).....	3
6	203715001	Cylinder w/Label.....	1
7	203664001	Latch Assembly.....	1
8	660380008	Screw (M3 x 10 mm).....	5
9	563549001	Rack Guide.....	1
10	203672001	Circuit Board Assembly.....	1
11	636592001	Block Plate.....	1
12	642378001	Cover.....	1
13	660385014	Screw (M5 x 20 mm).....	2
14	528417001	Depth of Drive Cover.....	1
15	203665001	Depth Adjustment Assembly (Inc. Key No. 14).....	1
16	T661853001	Screw (M4 x 4 mm).....	1
17	203666001	Magazine Assembly (Inc. Key Nos. 16, 18-20 and 45-46).....	1
18	525814004	No-Mar Pad.....	1
19	670974002	Hex Nut (M5).....	1
20	661154001	Screw (M5 x 30 mm).....	1
21	203667001	Gearbox Assembly (Inc. Key Nos. 22-23).....	1
22	673225003	Pin.....	2
23	660414015	Screw (M4 x 14 mm).....	4
24	203668001	Motor Assembly.....	1
25	660212001	Screw (M4 x 6 mm).....	1
26	636720001	Belt Hook.....	1
27	203670001	Driver Piston Assembly.....	1
28	203669001	Elevator Piston Assembly.....	1

KEY NO.	PART NUMBER	DESCRIPTION	QTY
29	662023004	Screw (M6 x 13 mm).....	1
30	563347001	O-Ring.....	1
31	524418003	Trigger.....	1
32	524852003	LED Trigger.....	1
33	634401001	Spring Plate.....	1
34	203671001	Housing Assembly (Inc. Key Nos. 43 and 47).....	1
35	694199001	Compression Spring.....	1
36	692784001	Compression Spring.....	1
37	524689003	Mode Trigger.....	1
38	660031029	Screw (M3.5 x 16 mm).....	10
39	529147001	Screw Plug.....	1
40	291524001	LED Assembly.....	1
41	941114129	Instruction Label.....	1
42	941114110	Trigger Wrap Warning Label.....	1
43	941114128	Logo Label.....	1
44	961152369	Hangtag Danger Label.....	1
45	941488137	Data Label.....	1
46	941488138	Fastener Label.....	1
47	941114127	Warning Label.....	1

Not Shown:

991000195	Operator's Manual	
203685001	Maintenance Kit	
203819001	WCE Maintenance Kit	
203673001	Seal Kit (Optional)	
903125001	Tool Bag	
693275001	Nails (1-1/4 in.).....	500
8-18-15	(Rev:01)	

CLÉ NO.	RÉF. DE PIÈCE	DESCRIPTION	QTÉ	CLÉ NO.	RÉF. DE PIÈCE	DESCRIPTION	QTÉ
1	662225001	Vis (M4 x 22 mm)	4	27	203670001	Ensemble du piston d'entraînement.....	1
2	352131001	Capuchon	1	28	203669001	Ensemble du dispositif de levage de piston.....	1
3	203663001	Ensemble de filtre de volet d'air (inclut le pièce 1).....	1	29	662023004	Vis (M6 x 13 mm)	1
4	563577001	Butoir	1	30	563347001	Joint torique.....	1
5	661923001	Vis (M4 x 15 mm)	3	31	524418003	Gâchette	1
6	203715001	Cylindre / étiquette	1	32	524852003	Gâchette de la DEL.....	1
7	203664001	Ensemble loquet	1	33	634401001	Siège de ressort.....	1
8	660380008	Vis (M3 x 10 mm)	5	34	203671001	Ensemble logement (inclut les pièces 43 et 47) ...	1
9	563549001	Guide de portoir.....	1	35	694199001	Ressort de compression.....	1
10	203672001	Ensemble de carte de circuit imprimé.....	1	36	692784001	Ressort de compression.....	1
11	636592001	Plaque de bois	1	37	524689003	Bouton « mode ».....	1
12	642378001	Couvercle.....	1	38	660031029	Vis (M3.5 x 16 mm)	10
13	660385014	Vis (M5 x 24 mm)	2	39	529147001	Bouchon vis.....	1
14	528417001	Couvercle de profondeur d'enfoncement.....	1	40	291524001	Ensemble du DEL	1
15	203665001	Ensemble de réglage de profondeur (inclut le pièce 14).....	1	41	941114129	Étiquette d'instructions.....	1
16	T661853001	Vis (M4 x 4 mm)	1	42	941114110	Autocollant de gâchette.....	1
17	203666001	Ensemble de magasin (inclut les pièces 16, 18-20 et 45-46).....	1	43	941114128	Étiquette de logo.....	1
18	525814004	Coussinet antimarques	1	44	961152369	Étiquette de danger	1
19	670974002	Écrou six pans (M5)	1	45	941488137	Étiquette d'information	1
20	661154001	Vis (M5 x 30 mm)	1	46	941488138	Étiquette d'agrafe	1
21	203667001	Ensemble de boîte d'engrenages (inclut les pièces 22-23).....	1	47	941114127	Étiquette d'avertissement	1
22	673225003	Broche	2	Non illustré :			
23	660414015	Vis (M4 x 14 mm)	4	991000195	Manuel d'utilisation		
24	203668001	Ensemble de moteur.....	1	203685001	Trousse d'entretien		
25	660212001	Vis (M4 x 6 mm)	1	203819001	Trousse d'entretien pour WCE		
26	636720001	Crochet de ceinture	1	203673001	Ensemble de joints (optionnel)		
				903125001	Sac à outils		
				693275001	Clous (1-1/4 po)	500	

NÚM REF.	NÚM PIEZA	DESCRIPCIÓN	CANT.
1	662225001	Tornillo (M4 x 22 mm).....	4
2	352131001	Tapa del extremo	1
3	203663001	Conjunto para filtro de obturador de aire (incl. núm. de ref. 1)	1
4	563577001	Tope	1
5	661923001	Tornillo (M4 x 15 mm).....	3
6	203715001	Cilindro / etiqueta	1
7	203664001	Conjunto de pestillo.....	1
8	660380008	Tornillo (M3 x 10 mm).....	5
9	563549001	Guía de cremallera.....	1
10	203672001	Conjunto de la placa de circuitos	1
11	636592001	Placa de bloque.....	1
12	642378001	Cubierta	1
13	660385014	Tornillo (M5 x 24 mm).....	2
14	528417001	Cubierta de profundidad de introducción.....	1
15	203665001	Conjunto de ajuste de profundidad (incl. núm. de ref 14)	1
16	T661853001	Tornillo (M4 x 4 mm).....	1
17	203666001	Conjunto del cargador (incl. núms. de ref 16, 18-20 y 45-46)	1
18	525814004	Almohadilla protectora.....	1
19	670974002	Tuerca hexagonal (M5).....	1
20	661154001	Tornillo (M5 x 30 mm).....	1
21	203667001	Conjunto del caja de engranajes (incl. núms. de ref. 22-23)	1
22	673225003	Pasador.....	2
23	660414015	Tornillo (M4 x 14 mm).....	4
24	203668001	Conjunto del motor.....	1
25	660212001	Tornillo (M4 x 6 mm).....	1
26	636720001	Gancho para el cinto	1

NÚM REF.	NÚM PIEZA	DESCRIPCIÓN	CANT.
27	203670001	Conjunto del pistón del desarmador	1
28	203669001	Conjunto del pistón de elevación	1
29	662023004	Tornillo (M6 x 13 mm).....	1
30	563347001	Junta tórica	1
31	524418003	Gatillo.....	1
32	524852003	Gatillo del LED	1
33	634401001	Placa del resorte	1
34	203671001	Conjunto de la armazón (incl. núms. de ref. 43 y 47).....	1
35	694199001	Resorte de compresión	1
36	692784001	Resorte de compresión	1
37	524689003	Botón mode	1
38	660031029	Tornillo (M3.5 x 16 mm).....	10
39	529147001	Enchufe de tornillo.....	1
40	291524001	Conjunto del LED.....	1
41	941114129	Etiqueta de instrucciones	1
42	941114110	Etiqueta del gatillo	1
43	941114128	Etiqueta del logotipo.....	1
44	961152369	Etiqueta de peligro.....	1
45	941488137	Etiqueta de datos.....	1
46	941488138	Etiqueta de sujetadores	1
47	941114127	Etiqueta de advertencia.....	1

No se muestra:

991000195	Manual del operador	
203685001	Kit de mantenimiento	
203819001	Kit de mantenimiento para WCE	
203673001	Kit del sello (opcional)	
903125001	Bolsa de herramientas	
693275001	Clavos (1-1/4 pulg.).....	500