

# bühler

## farm king

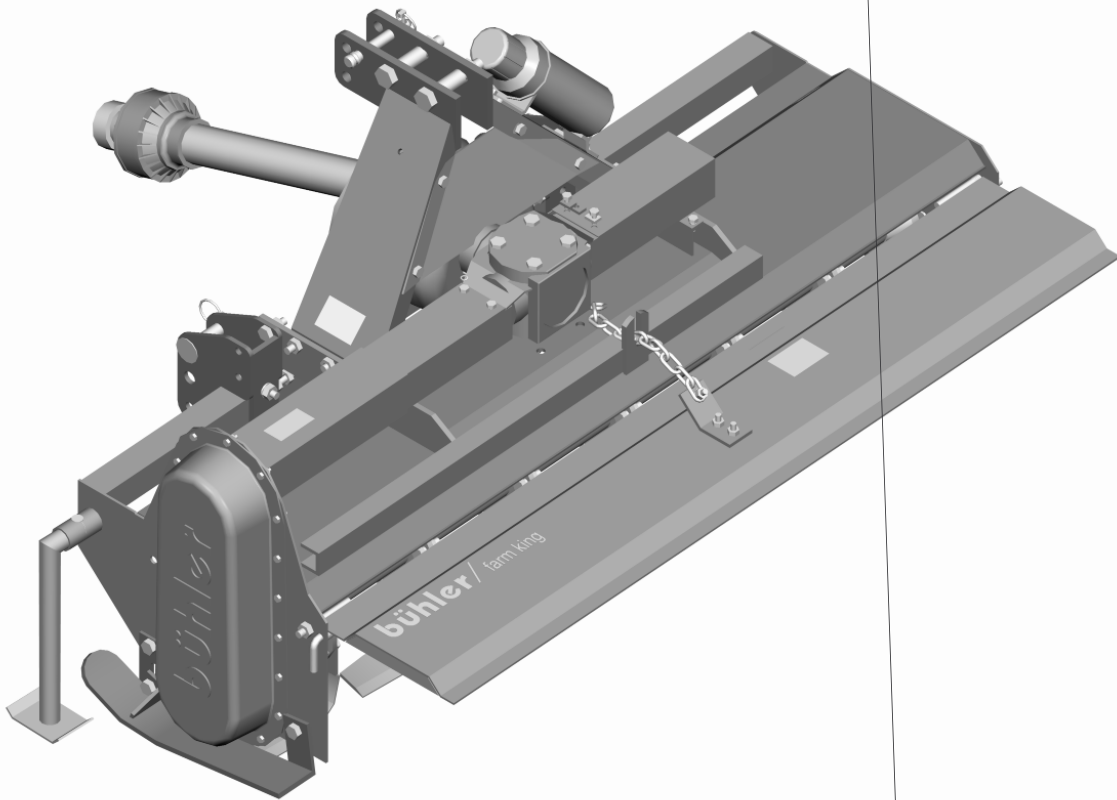

**40", 48" & 60"**  
**25 Series Rotary Tiller**

Operator's and Parts Manual  
FK303

2008



**TABLE OF CONTENTS**

<b>DESCRIPTION</b>	<b>PAGE</b>
<b>WARRANTY</b> .....	1
<b>INTRODUCTION</b> .....	2
<b>SAFETY</b> .....	3
Safety .....	3
General Safety .....	4
Start Up Safety .....	4
Operation Safety .....	4
Transport Safety.....	4
Service & Maintenance Safety .....	5
Storage Safety .....	5
Safety Signs .....	5
Safety Sign Installation.....	5
<b>ASSEMBLY</b>	
Assembly Instructions .....	7
<b>START UP</b> .....	7
Machine Break-In .....	7
<b>OPERATION</b> .....	8
Pre-Operation Checklist .....	8
Machine Components .....	9
Equipment Matching .....	10
Driveline Dimension .....	11
Attaching/Unhooking .....	13
Field Operation.....	14
Transporting .....	17
Storage .....	18
Theory of Operation .....	19
<b>MAINTENANCE</b> .....	20
Service .....	20
Fluids and Lubricants .....	20
Greasing .....	20
Servicing Intervals.....	21
A-Frame Adjustment .....	23
Tine Replacement .....	23
Shear Bolt .....	24
Slip Clutch .....	26
Troubleshooting .....	27
Bolt Torque	

**PARTS LISTS**

Tiller Drawings and Parts List.....	28
PTO (Shear Pin) Drawing & Parts List .....	33
PTO (Slip Clutch) Drawing & Parts List.....	35
Gearbox Drawing & Parts List.....	37

<b>SHIPPING KIT AND BUNDLE NUMBERS .....</b>	<b>38</b>
--	-----------

## WARRANTY POLICY

Buhler Manufacturing products are warranted for a period of twelve (12) months (90 days for commercial application) from original date of purchase, by original purchaser, to be free from defects in material and workmanship under correct, normal agricultural use and proper applications.

Buhler Manufacturing's obligations under this warranty shall be limited to the repair or exchange, at Buhler Manufacturing's option, of any Buhler Manufacturing product or part which proves to be defective as provided. Buhler Manufacturing reserves the right to either inspect the product at the buyer's location or have it returned to the factory for inspection.

The above warranty does not extend to goods damaged or subject to accident, abuse or misuse after shipment from Buhler Manufacturing's factory, nor to goods altered or repaired by anyone other than an authorized Buhler Manufacturing representative.

Buhler Manufacturing makes no Express Warranties other than those, which are specifically described. Any description of goods, including any references and specifications in catalogues, circulars and other written material published, is for the sole purpose of identifying goods and shall conform to such descriptions. Any sample or model is for illustrative purposes only and does not create an Express Warranty that the goods conform to sample or model shown.

The purchaser is solely responsible for determining suitability of goods sold. This warranty is expressly in lieu of all other warranties expressed or implied. Buhler Manufacturing will in no event be liable for any incidental or consequential damages whatsoever. Nor for any sum in excess of the price received for the goods for which liability is claimed.

### **WARRANTY CLAIMS:**

Warranty requests must be prepared on Buhler Manufacturing Warranty Claim Forms with all requested information properly completed. Warranty Claims must be submitted within a thirty (30) day period from date of failure repair.

### **WARRANTY LABOR:**

Any labor subject to warranty **must** be authorized by Buhler Manufacturing. The labor rate for replacing defective parts, where applicable, will be credited at 100% of the dealer's posted shop rate. Defective parts will receive an extra 10% discount to assist with freight or other incidental costs.

### **GOVERNMENT LEGISLATION:**

Warranty terms and conditions are subject to Provincial or State legislation.

### **IMPORTANT FACTS:**

Buckets and Bucket Tines Carry No Warranty  
Bent Spears Carry No Warranty  
Snowblower Fan Shafts Carry No Warranty  
Mower Blades Carry No Warranty  
Portable Auger Parts Have Two (2) Year Warranty  
Loader Parts Have Two (2) Year Warranty

**IMPORTANT NOTE: This warranty does not apply to rentals**

## INTRODUCTION

Buhler Farm King has a collection of rotary tiller models to suit your garden and landscaping needs. The 25 Series Tiller attaches to the 3-point hitch as well as our Cat. 1 Quick Hitch and is designed to fit a variety of tractors from 12 hp to 25 hp. Tilling widths range from 36" to 54" in the 25 Series.

The tilling shaft is equipped with four to six flanges, depending on the model. Flanges on all series are available with four tines. This provides an optimum balance between performance and durability, even in heavy soils and when breaking untilled soil.

Standard on all Buhler Farm King Rotary Tillers, the skid shoes are adjustable so it is easy to set the perfect tilling depth. The automatic chain tightener is standard on all models. This ensures the chain remains tight even under the toughest tilling conditions. Housing within a sealed oil bath, the chain tightener is designed to be reliable and maintenance-free. Getting close to the fences, hedges or covering a tire track is easy with the side shift feature. The entire unit can be pushed to one side, while the PTO shaft remains in line with the tractor to minimize stress on the universal joint. The side shift feature is available on all 25 Series Buhler Farm King Rotary Tillers.

Keep this manual handy for frequent reference. All new operators or owners must review the manual before using the equipment and at least annually thereafter. Contact your Buhler Dealer if you need assistance, information, or additional copies of the manual. Visit our website at [www.buhler.com](http://www.buhler.com) for a complete list of dealers in your area.

The directions left, right, front and rear, as mentioned throughout this manual, are as seen facing in the direction of travel of the implement.

## SAFETY

Remember, YOU are the key to safety. Good safety practices not only protect you, but also the people around you. Make these practices a working part of your safety program. Be certain that everyone operating this equipment is familiar with the recommended operating and maintenance procedures and follows all the safety precautions. Most accidents can be prevented. Do not risk injury or death by ignoring good safety practices.

The alert symbol is used throughout this manual. It indicates attention is required and identifies hazards. Follow the recommended precautions.



The safety alert symbol means...

**ATTENTION! BECOME ALERT! YOUR SAFETY IS INVOLVED!**

## CAUTION

The caution symbol indicates a potentially hazardous situation that, if not avoided, may result in minor or moderate injury. It may also be used to alert against unsafe practices.

## WARNING

The Warning Symbol indicates a potentially hazardous situation that, if not avoided, could result in death or serious injury, and includes hazards that are exposed when guards are removed. It may also be used to alert against unsafe practices.

## DANGER

The Danger Symbol indicates an imminently hazardous situation that, if not avoided will result in death or serious injury. This signal word is to be limited to the most extreme situations, typically for machine components that, for functional purposes, cannot be guarded.

## **GENERAL SAFETY**

Have a first-aid kit available for use and know how to use it.

Have a fire extinguisher available, stored in a highly visible location, and know how to use it.

Wear appropriate protective gear. This list includes but is not limited to:

- a hard hat
- Protective shoes with slip resistant soles
- Protective glasses or goggles
- Heavy gloves
- Wet weather gear
- Hearing protection
- Respirator or filter mask

Read and understand the Operator's Manual and all safety signs before operating, servicing, adjusting, repairing, or unplugging the equipment.

Do not attempt any unauthorized modifications to your Buhler product as this could affect function or safety, and could affect the life of the equipment.

Never start or operate the tiller except from the operator's station on the power unit.

Inspect and clean the working area before operating.

Keep hands, feet, clothing, and hair away from moving parts.

Ensure bystanders are clear of the area before operating.

## **START-UP SAFETY**

Do not let inexperienced operators or children run this equipment.

Place all tractor and machine controls in neutral before starting.

Operate only with ROPS and seatbelt equipped tractors.

Do not operate inside a building unless there is adequate ventilation.

Ensure all shields are in place and in good condition before operating.

Stay clear of PTO shaft and machine when engaging PTO.

## **OPERATING SAFETY**

Do not allow riders.

Do not wear loose fitting clothing during operation.

Never operate over 540 rpm PTO speed.

Never operate the equipment in the raised operation.

## **TRANSPORT SAFETY**

Review Transport Safety instructions in tractor manual before moving.

Check with local authorities regarding transport on public roads. Obey all applicable laws and regulations.

Make sure the SMV (Slow Moving Vehicle) emblem and all the lights and reflectors that are required by the local highway and transport authorities are in place, are clean, and can be seen clearly by all overtaking and oncoming traffic.

Never have the equipment in operation during transport.

Always travel at a safe speed.



## SERVICE AND MAINTENANCE SAFETY

Stop engine, set brake, remove ignition key, and wait for all moving parts to stop before servicing, adjusting, repairing, or unplugging.

Support the equipment with blocks or safety stands before working beneath it.

Follow good shop practices including

- keep service area clean and dry
- be sure electrical outlets and tools are properly grounded
- use adequate light for the job

Use only tools, jacks, and hoists of sufficient capacity for the job.

Replace and secure all shields removed during servicing before operating.

Use heavy leather gloves to handle sharp objects.

## STORAGE SAFETY

Store the unit in an area away from human activity.

Do not permit children to play on or around the stored machine.

Support frame on stands and blocks to provide a secure base.

## SAFETY SIGNS

The following illustration shows the approximate location and detail of safety signs.

Keep all safety signs clean and legible and replace any that are damaged or missing.

When original parts are replaced, any safety signs affixed to those parts should be replaced as well. Replacement safety signs are available from your local dealer.

## INSTALLATION OF SAFETY SIGNS

To install safety signs, ensure the installation area is clean and dry. Decide on the exact position before you remove the backing paper. Remove the smallest portion of the split backing paper and align over the specified area. Carefully, press in place. Slowly peel back the remaining paper and smooth the remaining portion in place. Small air pockets can be pierced with a pin and smoothed out.

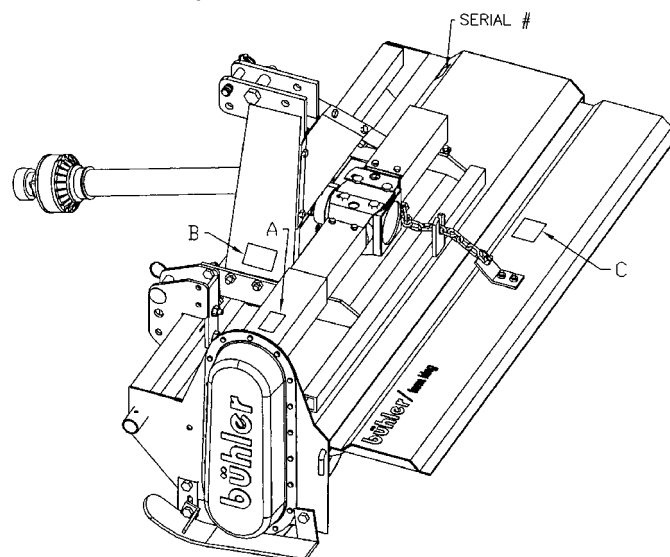

TL-08

**SAFETY SIGN LOCATIONS – cont'd.**

Safety sign "A"

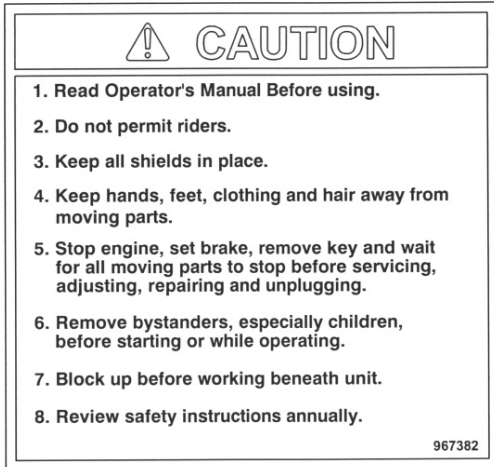

Safety sign "B"



Safety Sign "C"



Replace safety signs immediately should they become damaged, torn or illegible. Obtain replacements from your authorized dealer using the part numbers shown.

## ASSEMBLY

The machine is shipped with the PTO shaft not installed.

To install the PTO driveline on the machine, follow this procedure:

1. Clear the area of bystanders, especially small children.
2. Clean the splines on the yoke and the input shaft.
3. Align the splines on the yoke and the shaft.
4. Attach the driveline to the tiller by removing the tapered pin and sliding the yoke onto the gearbox shaft. Line up the pin with the groove in the gearbox shaft and fasten with the tapered pin. The plastic gearbox PTO guard has a removable door on top to access the pin. The A-frame brace can be removed to improve accessibility. Replace the brace after tightening the nut on the tapered pin.
5. Be sure the yoke is locked in position. Pull on the yoke to be sure the pin clicks into position.
6. Be sure that the PTO shaft is the appropriate length for the tractor/Tiller combination. Refer to Driveline Dimension Section for details.

## START UP

### MACHINE BREAK-IN

Although there are no operational restrictions on the Tiller when used for the first time, it is recommended that the following mechanical items be checked:

- A. After operating for 1/2 hour or after completing 1/2 acre:
  1. Check all nuts, bolts and other fasteners. Tighten to their specified torque level.
  2. Check that the blades are in good condition and bolted securely to the rotor.
  3. Check the oil level in the gearbox. Add as required.
  4. Check that the PTO driveline shield turns freely.
  5. Lubricate all grease points.
- B. After operating for 5 hours and 10 hours:
  1. Repeat items 1 through 5 of Section A.
  2. Then go to the regular service schedule as defined in Section 5.

### PRE-OPERATION CHECKLIST

Efficient and safe operation of the Rotary Tiller requires that each operator reads and understands the operating procedures and all related safety precautions outlined in this section. A pre-operation checklist is provided for the operator. It is important for both personal safety and maintaining the good mechanical condition of the Tiller that this checklist is followed.

Before operating the machine and each time thereafter, the following areas should be checked off:

- Lubricate the machine per the schedule outlined in the Service and Maintenance Section.
- Use only a tractor of adequate power and weight to pull the machine.
- Check that the machine is properly attached to the tractor. Be sure retainers are used on the mounting pins.
- Check the oil level in the gearbox. Add as required.
- Check that the PTO driveline shield turns freely and that the driveline can telescope easily. Clean and lubricate if required.
- Check the blades. Be sure they are not damaged or broken and are bolted securely to the rotor. Repair or replace as required.
- Remove any entangled material on rotating parts.
- Install and secure all guards, doors and covers before starting.
- The four socket set screws on the inside of the PTO clutch assembly must be turned out as far as they go to engage the clutch.

## OPERATION

### TO THE NEW OPERATOR OR OWNER

The Buhler Farm King 25 Series Rotary Tiller is a machine that combines the primary and secondary tillage operation into one machine. It breaks up the soil and prepares the seed bed in one pass. Rotational power to the rotor is provided by the tractor PTO. Be familiar with the machine before starting.

**It is the responsibility of the owner or operator to read this manual and to train all other operators before they start working with the machine. Follow all safety instructions exactly. Safety is everyone's business. By following recommended procedures, a safe working environment is provided for the operator, bystanders and the area around the work site. Untrained operators are not qualified to operate the machine.**

Many features incorporated into this machine are the result of suggestions made by customers like you. Read this manual carefully to learn how to operate the machine safely and how to set it to provide maximum field efficiency. By following the operating instructions in conjunction with a good maintenance program, your Tiller will provide many years of trouble-free service.

### MACHINE COMPONENTS

The Buhler Farm King 25 Series Rotary Tiller consists of a rotating drum that is equipped with bent blades for breaking up and leveling soil. The blades are turned through the soil while the machine moves over the working area. A Drag Shield is used to maintain a level seedbed. Rotational power to the drum is provided by the PTO on the tractor. The power is transmitted through the gearbox in the center of the machine to the chain drive down the side. The A-frame can be moved to offset the machine.

- A Point A-Frame
- B PTO Driveline
- C Gear Box
- D Chain Drive
- E Rotor
- F Blades
- G Skid Plates

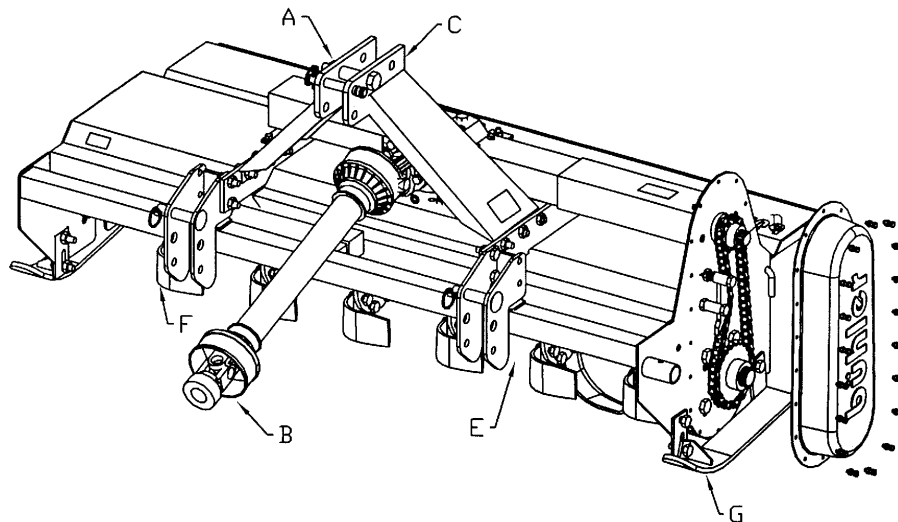

TL-09

**EQUIPMENT MATCHING**

To insure the safe and reliable operation of the Tiller, it is necessary to use a tractor with the correct specifications. Use the following list as a guide in selecting a tractor to use on the machine.

1. **Horsepower:** Use Table 1 as a guide in selecting the tractor horsepower appropriate for your width of machine. Use only small Agricultural tractors on this machine.

**Table 1 Horsepower vs. Width**

Model	Width	Horsepower
40S	40 inches (1.0m)	18
48S	4 feet (1.3m)	22
60S	5 feet (1.5m)	25



**ALERT:** Do not exceed the recommended horsepower levels. The use of horsepower will void the warranty.

2. **3 Point Hitch:**  
The Tiller is equipped with a Category 1, 3 point hitch. Be sure the tractor 3 point hitch is in the Category 1 configuration.

Install the lift arm blocks or shorten the stop chains to place the arms into the non-sway configuration. Refer to the tractor manual for details.

3. **Load Sensing Hydraulics:**  
Many newer tractors are equipped with "Load Sensing" hydraulics. It is the responsibility of the operator to set the tractor hydraulic system to provide "float" on the 3 point hitch.

The float feature will allow the machine to follow the ground contours during operation.

4. **PTO Shaft:**  
The tractor must have a 1 3/8" 6 spline 540 RPM PTO shaft to fit the driveline shaft supplied with the machine. Do not use shaft adapters or operate at any other speed.

It is not recommended that a tractor with variable speed PTO's be used on the Tiller. Operating at speeds faster than 540 RPM will overload the drivetrain and lead to early failures. Attach the safety chains supplied with the PTO shaft, allowing sufficient slack for the Driveline during turns and operation. Check booklet attached to the PTO for instructions.

## DRIVELINE DIMENSION

A PTO driveline is supplied with the machine. To accommodate the variety of 3 point hitch geometry available today, the driveline can be too long for some machines and must be cut. It is very important that the driveline be free to telescope but not bottom out when going through its working range. If the driveline bottoms out, the bearings on both the machine and tractor PTO shaft will be overloaded and fail in a short time.

When cutting the driveline, follow this procedure:

1. Clear the area of bystanders, especially small children.
2. Attach the Tiller to the tractor but do not attach the driveline.
3. Raise the machine until the input shaft is level with the tractor PTO shaft.
4. Measure the dimension between the locking groove on the tractor PTO shaft and the groove on the Tiller input shaft.
5. Measure the same dimensions on the compressed driveline.

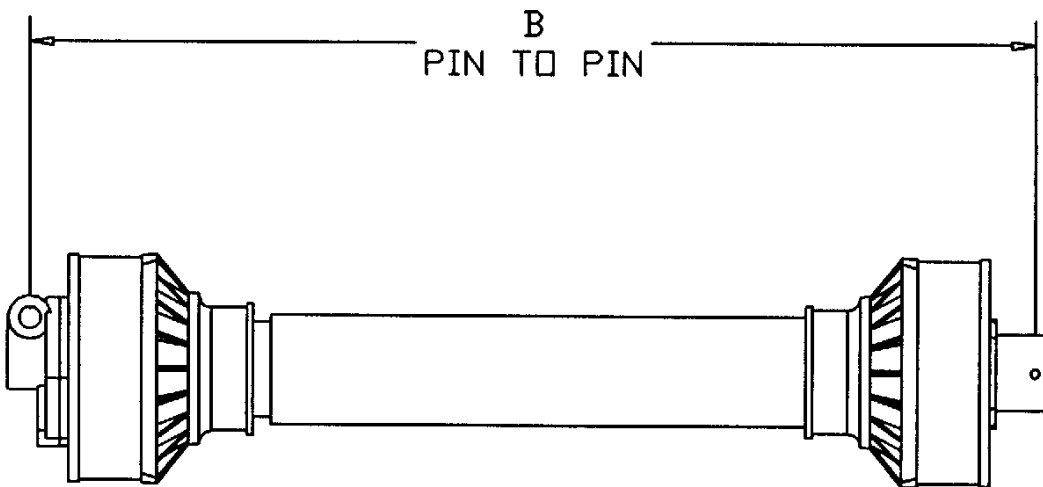

TL-10

6. If the driveline dimension exceeds the machine dimension, the driveline will have to be cut.

**DRIVELINE DIMENSION – cont'd.**

7. Pull the driveline apart and cut 1/2 of the dimension determined in step 5 from each end. Add another 1/2 inch (12MM) to each cut off segment.

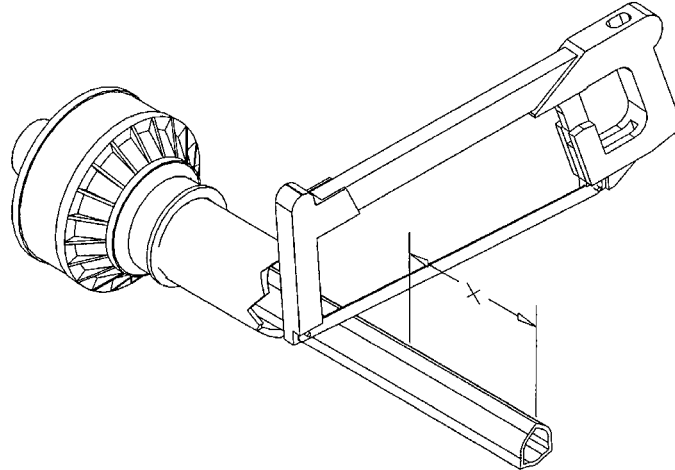

TL-11

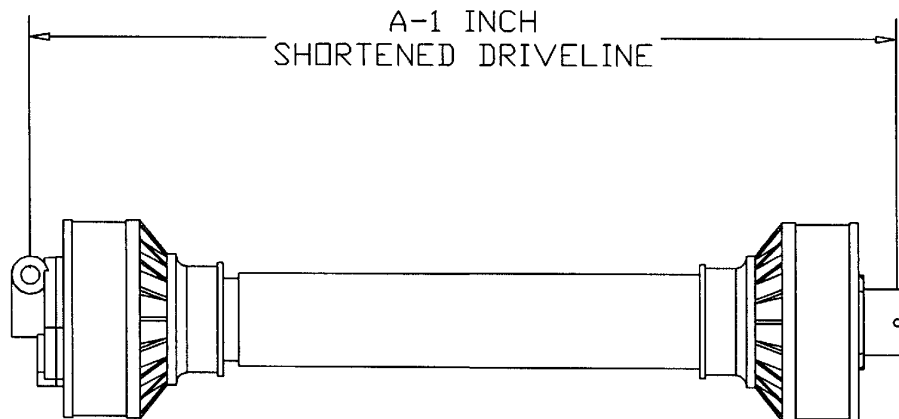



TL-12

8. Be sure to use a hacksaw to cut 1/2 from each end of the separated shaft. Cut both the plastic tube and the metal cores.
9. Use a file to remove the burrs from the edges that were cut.
10. Assemble the two ends of the shaft.
11. Make sure that the shaft can telescope freely. If it does not, separate the two parts and inspect for burrs or cuttings on the shaft ends. Be sure it telescopes freely before installing.
12. Make sure the plastic covering shield is free to rotate on the shaft before installing on the machine.



## ATTACHING/UNHOOKING

The Tiller should always be located on a level, dry area that is free of debris and other foreign objects. When attaching the machine to a tractor, follow this procedure:

1. Clear the area of bystanders, especially small children.
2. Be sure the tractor 3 point hitch is in the Category 1 configuration and the lift arms are in the non-sway configuration (See tractor manual).
3. Make sure there is enough room and clearance to safely back up to the Tiller.
4. Attach the PTO driveline to the Tiller if it was removed for storage (See Assembly).
5. While backing up, align the lift arm balls with the mounting pins on the Tiller.  
 **ALERT:** It may be necessary to add weight to the 3-point hitch to lower the lift arms.
6. Stop tractor, set park brake, remove ignition key and wait for all moving parts to stop before dismounting.
7. If your tractor is not equipped with a Quick Hitch:
  - a. Align the left lower link arm with the mounting pin.
  - b. Slide the ball over the pin and install the Linch Pin.
  - c. Use the screw jack on the right lift arm to align the ball with the pin.
  - d. Slide the ball over the mounting pin and install the Linch Pin.
  - e. Level the frame using the screw jack.
  - f. Remove retainer and pin from the mast.
  - g. Align top link using the turnbuckle.
  - h. Insert pin and install Linch Pin
  - i. Level frame using the turnbuckle.
8. Attach the PTO driveline:
  - a. Check that the driveline telescopes easily and that the shield rotates freely.  
 **CAUTION:** Be sure that the driveline does not bottom out when going through its working angles.
  - b. Attach the driveline to the tractor by retracting the locking pin, slide the yoke over the shaft and push on the yoke until the lock pin clicks into position. Pull on the yoke to be sure it is locked in position.
  - c. Attach the anchor chain on the driveline shield to the frame.
9. Use the 3 point hitch to raise the machine.
10. Remove the blocks from under the Depth Gauge Shoes.
11. Reverse the above procedure when unhooking from the tractor.

## FIELD OPERATION

Buhler Farm King 25 Series Rotary Tillers are designed with the inherent flexibility of operating well in almost any kind of soil and terrain conditions. However, the operator has the responsibility of being familiar with all operating and safety procedures and following them.

Each operator should review this section of the manual at the start of the season and as often as required to be familiar with the machine. When using, follow this procedure:

1. Review and follow the pre-operation Checklist. Review Safety Instructions.
2. Attach the tractor to the machine. See Attaching/Unhooking Section.
3. Before going to the field review Transporting Section.
4. Pull into the field and position the machine in a level area.
5. Lower into working position.
6. Set the machine:
  - a. Level the frame:  
Use the screw jack on the right lift arm to level the frame from side-to-side.
  - b. Depth: Use the Depth Gauge Shoes on each side to set the operating depth. Position the Depth Gauge Shoes in the top hole for shallow tilling and in the bottom hole for deep tilling.

**⚠ ALERT:** In soft soil conditions, the skid plates become less effective and sink into the ground. Use the turnbuckle on the top link to set the frame angle so the bottom of the Depth Gauge Shoes are level when operating.

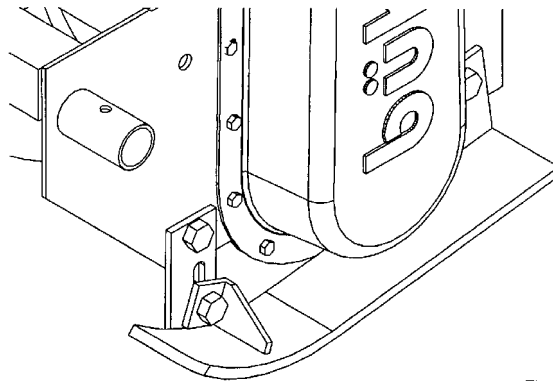

TL-13

### Offset:

The Category Pin Brackets can be moved 3 to 4 inches along the Deck Assembly to either side of center if required. Center the machine for normal operation. Offset if the tire tracks are wider than the machine or when tilling around trees, bushes or other areas.

### c. Drag Shield:

Adjust the chain in the Adjustment Bracket to set the height of the Drag Shield. Set the Drag Shield to just contact the tilled soil when operating.

**FIELD OPERATION - cont'd.**

7. Align the unit with the working area.
8. Starting machine:
  - a. Run the engine at low idle.
  - b. Slowly engage the PTO control to start the machine.
  - c. Slowly bring the engine to the rated PTO speed. Never exceed rated speed.
  - d. Lower the machine to the ground and proceed down the field.
9. Stopping machine:
  - a. Slowly decrease engine speed to low idle.
  - b. Raise machine out of the ground.
  - c. Disengage PTO clutch slowly.



**CAUTION:** Place all controls in neutral, lower machine, stop engine, set park brake remove ignition key and wait for all moving parts to stop before dismounting.

10. Ground Speed:

Travel speed can vary between 2 and 5 mph (3 and 8 km/h) depending on the soil and terrain conditions. It is the responsibility of the operator to note the condition of the job being done and set the speed to obtain a quality tilling job and maintain control of the machine.

The speed can be increased to optimize tilling.

Decrease speed if you want the soil worked to a finer texture.

11. Operating hints:
  - a. Determine the moisture content of the soil before starting. Soil that is too wet will "ball-up" in the rotor blades making tilling impossible. Sandy soils normally can be worked better than heavy clay or loam soils. It is the responsibility of the operator to determine the soil type and moisture content before starting. It may be necessary to wait for the soil to dry out before starting to work.
  - b. Set the length of the Top Link to obtain the quality of the job desired without needlessly using power and fuel in churning the soil. Use the condition of the seedbed as your guide.
  - c. When tilling hard or compacted soils, it is recommended that two passes be used when working. Use the Depth Gauge Shoes on each side of the frame to adjust the tilling depth of the machine. The second pass should be made at an angle to the first to give a consistent job and minimize compaction.
  - d. Always remove heavy crop cover, all grass and weeds, before starting to prevent rotor plugging.

**FIELD OPERATION - cont'd.**

- e. The rotation of the Tines propel the machine in the forward direction. Always use the tractor transmission to control the speed of forward travel.
- f. Always disengage the PTO control and raise the machine out of the ground before depressing the master clutch on the tractor.
- g. Use low gear on the tractor to start the job. Increase the speed of forward travel only as the quality of the job and power available will allow.
- h. If the slip clutch slips, reduce the ground speed or raise the machine slightly out of the ground.

**TRANSPORTING**

When transporting the machine, review and follow these instructions:

1. Be sure all bystanders are clear of the machine.
2. Be sure that the machine is securely attached to the tractor and all retainer pins are installed.
3. Clean the SMV emblem, lights and reflectors and be sure they are working.
4. Be sure you are in compliance with all applicable lighting and marking regulations when transporting. Check with your local authorities.
5. Be sure your machine can clearly be seen by overtaking and oncoming traffic.
6. Keep to the right and yield the right-of-way to allow faster traffic to pass. Drive on the road shoulder if permitted by law.
7. Do not allow riders.
8. Always use hazard flashers on the tractor when transporting unless prohibited by law.
9. Use pilot vehicles front and rear when transporting during times of limited visibility.
10. Never transport the machine faster than 20 mph (32 km/h). The ratio of the tractor weight to the Tiller weight plays an important role in defining acceptable travel speed. Table 2 summarizes the recommended travel speed to weight ratio.

**Table 2 Speed vs. weight Ratio**

Road Speed	Weight of fully equipped or loaded implement(s) relative to weight of towing machine
Up to 32 km/h (20 mph)	1 to 1, or less
Up to 16 km/h (10 mph)	2 to 1, or less
Do not tow	More than 2 to 1

## STORAGE

After the season's use, the machine should be thoroughly inspected and prepared for storage. Repair or replace any worn or damaged components to prevent any unnecessary down time at the start of next season. To insure a long, trouble free life, this procedure should be followed when preparing the unit for storage:

1. Clear the area of bystanders, especially small children.
2. Thoroughly wash the machine using a pressure washer to remove all dirt, mud, debris and residue.
3. Inspect the blades and rotors for damage or entangled material. Repair or replace damaged parts. Remove all entangled material.
4. Change the oil in the gear box.
5. Lubricate all grease fittings. Make sure that all grease cavities have been filled with grease to remove any water residue from the washing.
6. Touch up all paint nicks and scratches to prevent rusting.
7. Move to storage area.
8. Select an area that is dry, level and free of debris.
9. Place blocks under the Depth Gauge Shoes.
10. Unhook from tractor.
11. If the machine cannot be placed inside, cover with a waterproof tarpaulin and tie securely in place.
12. Store the machine in an area away from human activity.
13. Do not allow children to play on or around the stored machine.

THEORY OF OPERATIONS

TINE ROTATION

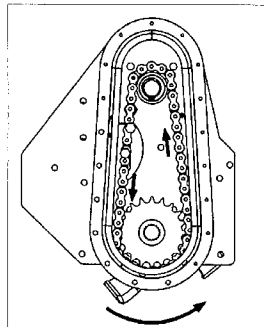

SIDE SHIFT BLADE 2 1/2" TO 17" DEPENDING ON SERIES

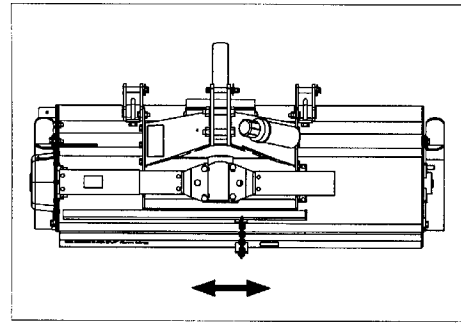

## **MAINTENANCE**

### **SERVICE**

Follow Maintenance Safety Instructions as outlined.

### **FLUIDS AND LUBRICANTS**

1. Hydraulic Oil:  
Use a standard hydraulic oil for all operating conditions.
2. Gear Box Oil:  
Use an SAE 85W90 gear oil for all operating conditions.  
  
Gear Box Capacity: 1 U.S. quart (0.85 liter)
3. Chain Case Grease:  
Use a multi purpose grease for all operating conditions.  
If chain case is removed, refill with 800 grams of grease.
4. Storing Lubricants:  
Your machine can operate at top efficiency only if clean lubricants are used. Use clean containers to handle all lubricants. Store them in an area protected from dust, moisture and other contaminants.

### **GREASING**

Use a Maintenance Checklist to keep a record of all scheduled maintenance.

1. Use a hand-held grease gun for all greasing.
2. Wipe grease fitting with a clean cloth before greasing, to avoid injecting dirt and grit.
3. Replace and repair broken fittings immediately.
4. If fittings will not take grease, remove and clean thoroughly. Also clean lubricant passageway. Replace fitting if necessary.



**SERVICING INTERVALS**

The periods recommended below are based on normal operating conditions. Severe or unusual conditions may require more frequent lubrication or oil changes.

**8 Hours or Daily; Telescoping Tubes and Quick Disconnect 20 Hours**

1. Lubricate PTO driveline (7 locations).

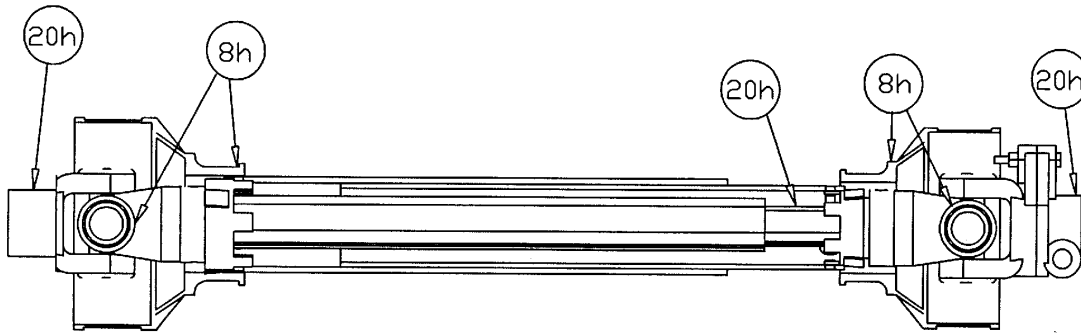

TL-14



**ALERT:** When using the safety chains supplied with the PTO shaft, the shield bearings must be kept lubricated.

**80 hours or once a season:**

2. Lubricate rotor driven end bearing (1 location)
3. Lubricate rotor drive end bearing (1 location).
4. Lubricate chain drive bearing (1 location)



- use 3 squirts only
- push grease in gradually

**SERVICING INTERVALS – cont'd.**

**40 Hours**

1. Check gearbox oil level.  
Add as required

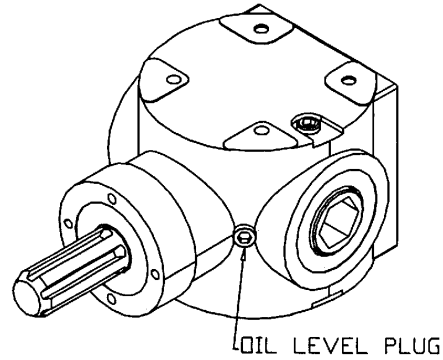

TL-16

2. Add approximately 10 squirts  
of grease in chain case.

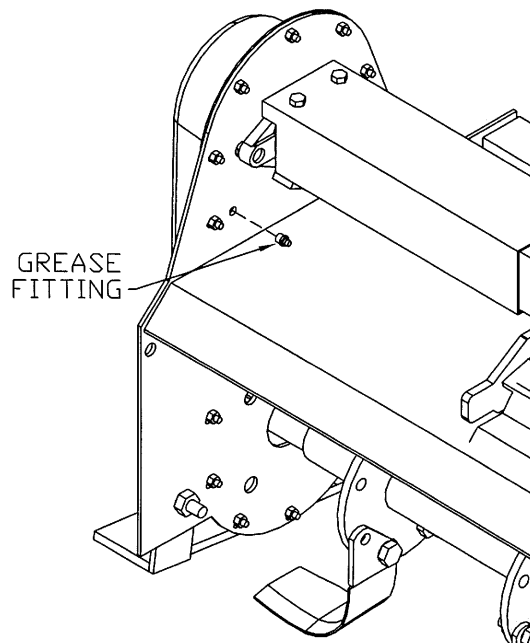

TL-17

**Annually**

1. Change gearbox oil. Refill with SAE 85W90 gear oil.
2. Wash machine.

## MAINTENANCE

By following a careful service and maintenance program for your machine, you will enjoy many years of trouble-free operation.

### A-FRAME ADJUSTMENT

When moving the hitch along the front frame to adjust the offset, follow this procedure:

1. Clear the area of bystanders, especially small children.
2. Raise the machine so it is slightly out of the ground.
3. Loosen the u-bolts through the Category Pin brackets.
4. Slide the A-frame along the Deck until the machine is set at the desired offset.
5. Tighten the clamping bolts to their specified torque.

### TINE REPLACEMENT

When the tines are damaged in any way, they will need to be replaced. When replacing, follow this procedure:

1. Clear the area of bystanders, especially small children.
2. Raise the machine until the tines are slightly above the ground.
3. Stop engine, set park brake, remove ignition key and wait for all moving parts to stop before dismounting.
4. Place blocks under each Depth Gauge Shoe to support the machine.
5. Raise the Drag Shield and secure in the up position.
6. Wear leather or heavy canvas gloves when handling Tines.
7. Remove mounting bolts from Tine.



**ALERT:** An alternate method would be to disconnect the machine from the tractor and tip it forward on its nose.

8. Install a new replacement blade and tighten the mounting bolts to their specified torque.
9. Lower the rear gate.
10. Remove the blocks under the skid plates.

## SHEAR BOLT

A shear pin is provided in the input drive shaft at the gearbox to protect the drive system during an overload. To change the shear pin, follow this procedure:

1. Place all controls in neutral, stop engine, set park brake, remove ignition key and wait for all moving parts to stop before dismounting.
2. Disconnect the PTO shaft from the tractor and lay to the side.
3. Carefully remove remaining shear bolt using a hammer and punch if necessary. Be careful not to enlarge the holes.
4. Install the new shear bolt and tighten. (6mm & 40mm, Gr.5)



**ALERT:** Use only genuine Buhler Farm King parts. These shear bolts are specially designed to provide protection for the drive system. Do not install just any bolt.

## SLIP CLUTCH (OPTIONAL)

During normal operation, the slip clutch can release and slip when encountering an obstruction or when overloaded. It is designed to slip when the load exceeds 3 times its nominal rating. When the clutch slips too frequently during normal operating conditions, it is necessary to replace the clutch linings. **NOTE:** The PTO shafts are shipped with the slip clutch disengaged. There are four socket set screws on the inside of the clutch assembly, which are turned out as far as they go to engage the clutch. Disengage clutch by turning set screws in fully.

To replace clutch linings, follow this procedure:

1. Disengage the clutch by turning the four set screws all the way in.
2. Remove the outside bolts from the clutch assembly and replace the clutch linings.
3. When re-tightening the bolts, stop when the clutch spacer starts to touch the clutch plates. You should be able to just move the spacer by hand when you have the correct bolt torque.
4. Engage clutch by turning out set screws after assembly is complete.

## CLUTCH MAINTENANCE

1. Before first use or after storage of more than one month, the clutch should be checked.
2. Disengage clutch by turning in the four socket set screws.
3. Run the PTO at low idle to slip the clutch linings. This will help remove the dirt, corrosion, and surface gloss from the clutch plates and also ensure that the linings are loose.
4. Engage the clutch by turning out the socket set screws.
5. Normally the clutch will slip at a 20% higher torque after the “run in” than before.
6. Check the temperature of the clutch after running for 20 minutes and every 8 hours after that. If the clutch is hot to the touch or smokes, check that the outside bolts are correctly tightened as explained in slip clutch section. If clutch still slips, linings may have to be replaced.

**TROUBLE SHOOTING**



The Buhler Farm King 25 Series Rotary Tiller moves curved Tines on a turning rotor through the ground to break it up and prepare a seed bed. It is a simple and reliable system that requires minimal maintenance.

In the following section, we have listed many of the problems, causes and solutions to the problems that you may encounter.

If you encounter a problem that is difficult to solve, even after having read through this trouble shooting section, please call your local Buhler Farm King distributor dealer. Before you call, please have this Operator's Manual and the serial number from your Tiller ready.

<b>PROBLEM</b>	<b>CAUSE</b>	<b>SOLUTION</b>
Rotor won't turn.	Slip clutch slipping.	Check that clutch is engaged or replace friction plates.
	PTO clutch slipping.	Set PTO clutch. See tractor manual.
	Broken drive chain.	Repair or replace chain.
****		
Untilled ground behind machine.	3 point hitch not set.	Set 3 point hitch in float. See tractor manual.
	Traveling too fast.	Travel slower.
	Ground very hard.	Slow down. Make 2 passes.
	Machine not leveled.	Adjust screw jack on 3 point arm. Adjust Depth Gauge Shoes.
****		
Seed bed lumpy.	Traveling too fast.	Slow down. Make 2 passes.
****		
Uneven seed bed.	Machine not level.	Level machine.
	Drag Shield too high.	Adjust Drag Shield.

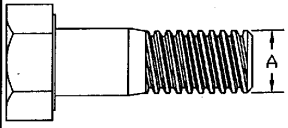
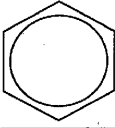
**BOLT TORQUE**

Bolt Torque						
						
Bolt Diameter	SAE2		SAE5		SAE8	
"A"	N.m	lb-ft	N.m	lb-ft	N.m	lb-ft
1/4"	8	6	12	9	17	12
5/16"	13	10	25	19	36	27
3/8"	27	20	45	33	63	45
7/16"	41	30	72	53	100	75
1/2"	61	45	110	80	155	115
9/16"	95	70	155	115	220	165
5/8"	128	95	215	160	305	220
3/4"	225	165	390	290	540	400
7/8"	230	170	570	420	880	650
1"	345	225	850	630	1320	970

40", 48" & 60" 25 SERIES TILLERS

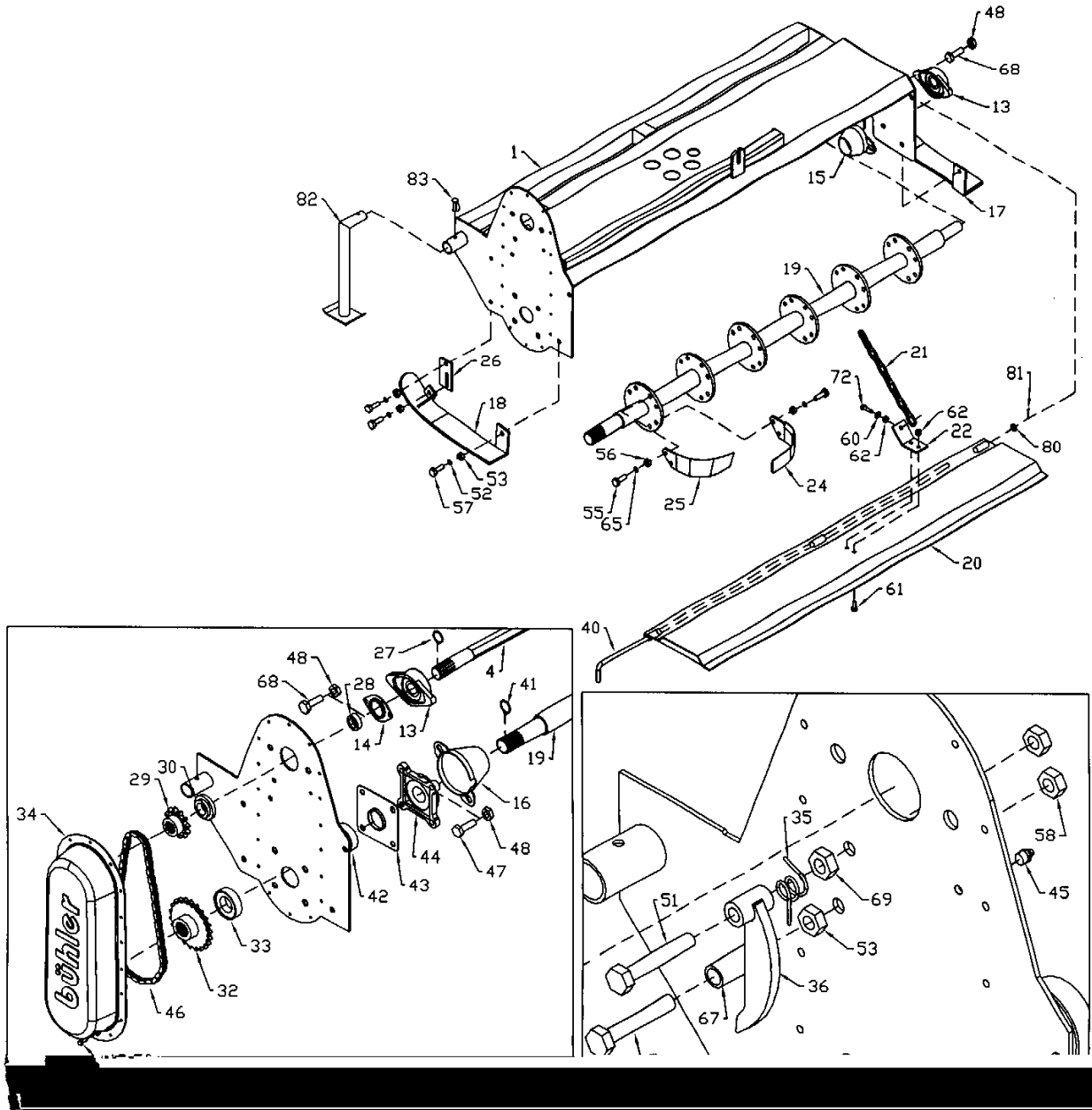



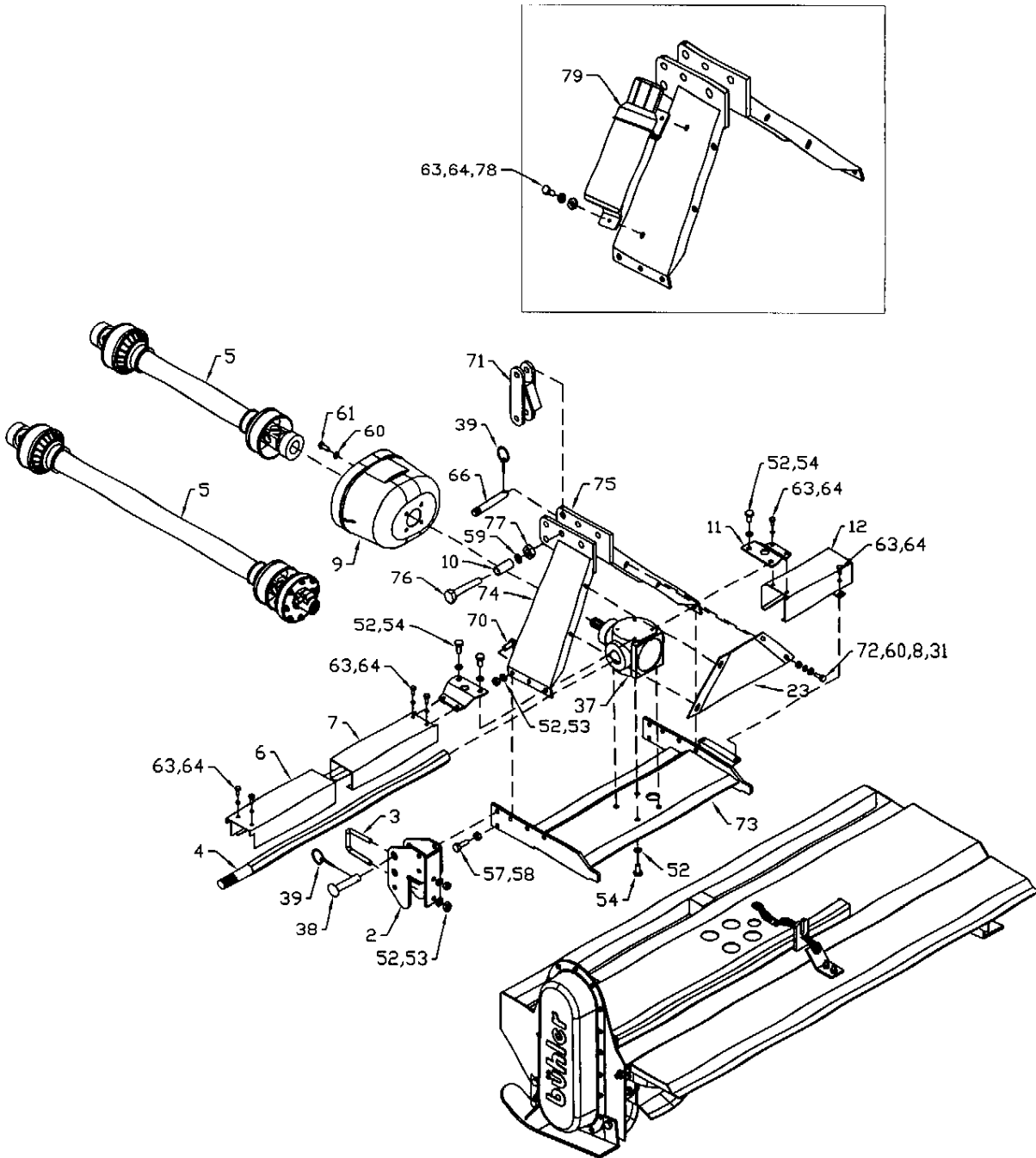

TL-01a

**PARTS LIST**

**WHEN ORDERING PARTS**

Always give your dealer the Model, Color and Serial Number of your machine to assist him in ordering and obtaining the correct parts. Use the exploded view and tabular listing of the area of interest to exactly identify the required part.

**40", 48", & 60" 25 SERIES TILLERS**

<b>ITEM</b>	<b>PART #</b>	<b>DESCRIPTION</b>
1	906290	Deck Weldment (40")
	906291	Deck Weldment (48")
	906292	Deck Weldment (60")
2	967348	Category Pin Bracket Weldment
3	967350	1/2" U-Bolt
4	959224	Hex Drive Shaft (40")
	959225	Hex Drive Shaft (48")
	959226	Hex Drive Shaft (60")
5	F0356	PTO Shaft w/ Slip Clutch
	F0357	PTO Shaft w/ Shear Pin
6	983405211	Drive Shaft Shield - Outer (40")
	983485211	Drive Shaft Shield - Outer (48")
	983605211	Drive Shaft Shield - Outer (60")
7	983405311	Drive Shaft Shield - Inner (40")
	983485311	Drive Shaft Shield - Inner (48")
	983605311	Drive Shaft Shield - Inner (60")
8	81593	3/8" Lock Washer
9	912300165	Gearbox PTO Guard
10	903171	Spacer 1.05" OD x 2 1/4"
11	983005111	Shield Mount Weldment
12	903319	Drive Shaft Shield Weldment - Right
13	912300131	1 1/4" - 2 Bolt Flange Bearing
	961676	1 1/4" Bearing Only (greasable)
14	983006222	1 1/4" Oil Seal Plate
15	983006300	Shaft Cover - Right
16	967353	Bearing Cover - Left
17	983000200	Depth Gauge Shoe Weldment - Right
18	983000250	Depth Gauge Shoe Weldment - Left
19	967354	Rotor Shaft Weldment (40")
	967355	Rotor Shaft Weldment (48")
	967356	Rotor Shaft Weldment (60")
20	909729	Drag Shield (40")
	909730	Drag Shield (48")
	909731	Drag Shield (60")

21	983000471	1/4" X 11 Link Chain
22	967357	Drag Shield Bracket
23	903156	A-Frame Brace Plate
24	967483	Tine - Right
25	967484	Tine - Left
26	983000241	Depth Gauge Shoe Bracket
27	967386	1 1/4" Retainer Ring
28	912303405	1 1/4" Oil Seal
29	912300172	60-B-12 Sprocket
30	959222	Top Sprocket Spacer 2 1/2"OD x 13/16" long
31	81592	3/8" Hex Nut
32	967359	60-B-22 Sprocket
33	959223	Bottom Sprocket Spacer 3"OD x 13/16" long
34	903209	Chain Guard
35	982005711	Tension Spring
36	967377	Chain Tensioner Weldment
37	912300164	4033 B Gearbox
38	967361	7/8" x 4" Clevis Pin
39	965911	7/16" Linch Pin
40	909710	Drag Shield Hinge Rod (40")
	909711	Drag Shield Hinge Rod (48")
	909712	Drag Shield Hinge Rod (60")
41	912301557	1 5/8" Retainer Ring
42	912303601	1 5/8" Oil Seal
43	982006422	1 5/8" Oil Seal Plate
44	967363	1 5/8" 4-Bolt Flange Bearing
	967364	1 5/8" Bearing only
45	967164	Pound-In Grease Fitting
46	906313	60H Roller Chain (55 Link w/ Connector & Offset)
47	84299	5/8" x 2" Hex Bolt
48	812482	5/8" Lock Nut
49	81525	1/4" x 3/4" Hex Bolt
50	84498	1/4" Lock Nut
51	81627	1/2" x 3" Hex Bolt
52	81637	1/2" Lock Washer
53	81636	1/2" Hex Nut
54	81619	1/2" x 1" Hex Bolt
55	812763	1/2" x 1 1/2" GR.8 Hex Bolt (NF)
56	812765	1/2" GR.8 Hex Nut (NF)
57	84277	1/2" x 1 1/2" Hex Bolt
58	812364	1/2" Lock Nut
59	81701	3/4" Lock Washer
60	84000	3/8" B.S. Flat Washer
61	84072	3/8" x 3/4" Hex Bolt
62	812363	3/8" Lock Nut
63	812026	5/16" x 1" Hex Bolt

---

64	81569	5/16" Lock Washer
65	9812767	1/2" GR.8 Lock Washer
66	965807	CAT. 1 Top Link Pin
67	967279	Tension Spring Spacer (1 5/8" Long)
68	84270	5/8" x 1 3/4" Hex Bolt
69	984077	1/2" Hex Jam Nut
70	81620	1/2" x 1 1/4" Hex Bolt
71	902676	Adapter Weldment Category 1 to 0
72	86170	3/8" x 1" Hex Bolt
73	903158	A-Frame Bottom Weldment
74	903159	A-Frame Top Left Hand Weldment
75	903160	A-Frame Top Right Hand Weldment
76	811790	3/4" x 4 1/2" Hex Bolt
77	81700	3/4" Hex Nut
78	81568	5/16" Hex Nut
79	909277	Manual Holder
80	84048	1/2" Flat Washer
81	9812433	1 1/2" Cotter Pin
82	982000500	Side Stand Weldment
83	912301660	Snapper Clip

25 SERIES TILLER PTO (SHEAR PIN)

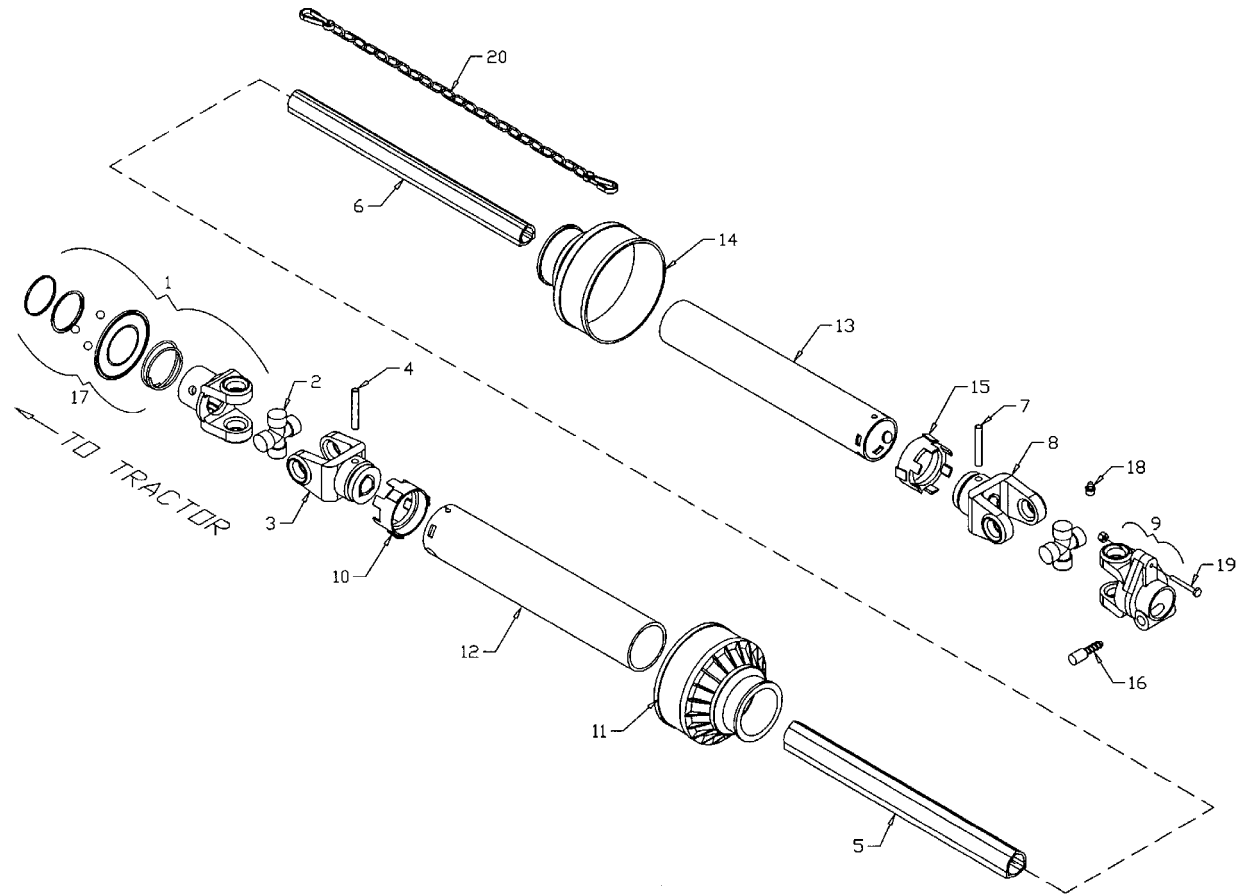

TL-02

**25 SERIES TILLER PTO PARTS LIST (SHEAR PIN)**

<b>ITEM</b>	<b>PART NO.</b>	<b>DESCRIPTION</b>
	F0357	Shaft Complete
	908251	Outer Half Shaft - Tractor
	908252	Inner Half Shaft w/Shear - Implement
1	907290	Yoke RS
2	920-002	Ser 2 Repair Kit
3	920-004	Outer Tube Yoke
4	920-006	Flexible Pin
5	920-009	Outer Cardan Tube
6	920-010	Inner Cardan Tube
7	930-109	Flexible Pin
8	920-003	Inner Tube Yoke
9	908245	Shear Assembly
10	920-013	Outer Bearing
11	936300	Outer Cone Set
12	920-018	CM. Shield Tube (Outer)
13	920-012	CM. Shield Tube (Inner)
14	936305	Inner Cone Set
15	920-015	Inner Bearing
16	966213	Complete Push Button
17	908244	Ball Collar Kit
18	908247	Grease Zerk
19	920-020	Shear Pin & Nut
20	936402	Safety Chain

25 SERIES TILLER PTO (SLIP CLUTCH)

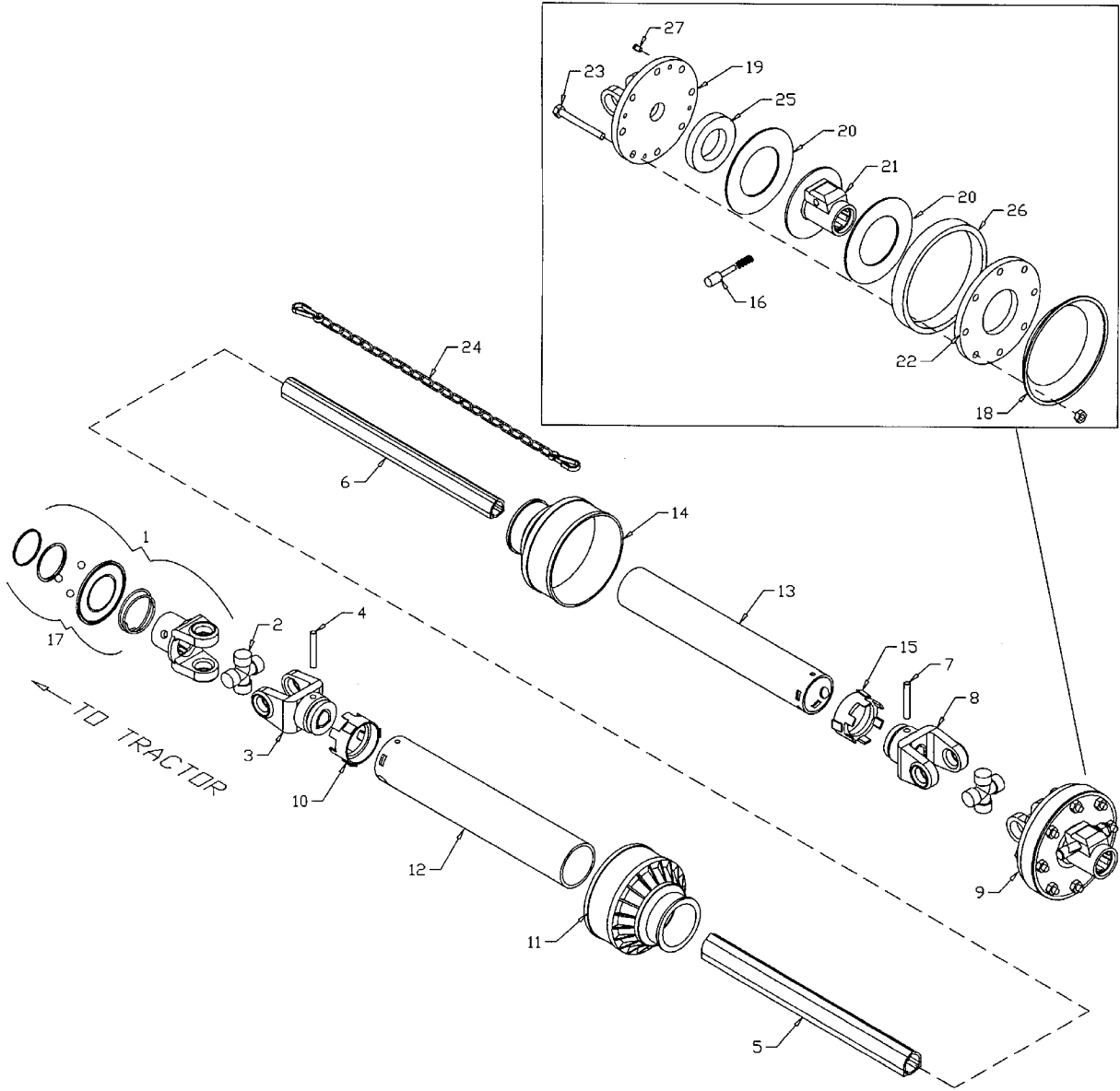

TL-03

**25 SERIES TILLER PTO PARTS LIST (SLIP CLUTCH)**

<b>ITEM</b>	<b>PART NO.</b>	<b>DESCRIPTION</b>
	F0356	Shaft Complete
	908258	Outer Half Shaft
	936515	Inner Half Shaft
1	907290	Yoke
2	920-002	Ser 2 Repair Kit
3	920-004	Outer Tube Yoke
4	920-006	Flexible Pin
5	936560	Outer Cardan Tube
6	936561	Inner Cardan Tube
7	930-109	Flexible Pin
8	920-003	Inner Tube Yoke
9	936503	Torque Lim, DF
10	920-013	Outer Bearing
11	936300	Outer Cone Set
12	936504	Outer Safety Tube
13	936505	Inner Safety Tube
14	936506	Inner Cone Set
15	920-015	Inner Shield Support
16	966213	Complete Push Button
17	908244	Ball & Collar Kit
18	936513	Spring
19	936508	Flange Yoke
20	936340	Clutch Lining
21	936511	Hub c/w Q.D.
22	936510	Pressure Plate
23	936507	Clutch Screw
24	936402	Safety Chain
25	966223	Anti-Friction Sleeve
26	936514	Cover
*27	936512	Set Screw

\* Set Screw should be backed out all the way to engage clutch



**25 SERIES TILLER GEARBOX**

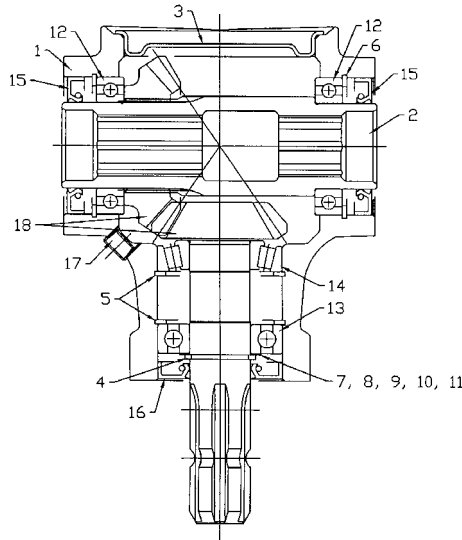

TL-04

**25 SERIES TILLER GEARBOX PARTS LIST**

ITEM	PART NO.	DESCRIPTION	QUANTITY
	912300164	Gearbox Complete	1
1	967300	Housing	1
2	967301	Hex Shaft 35.2mm Diameter	1
3	967302	Cover 110mm Diameter	1
4	967303	Snap Ring, E.35, DIN 471/2	1
5	967304	Snap Ring, I.72, DIN 472	2
6	967305	Snap Ring, I.80, DIN 472	2
7	967314	Ring, 35.2 x 44.7 x .6	As Required
8	967315	Ring, 35.2 x 44.7 x .8	As Required
9	967316	Ring, 35.2 x 44.7 x 1.0	As Required
10	967317	Ring, 35.2 x 44.7 x .3	As Required
11	967318	Ring, 35.2 x 44.7 x .4	As Required
12	967306	Ball Bearing, 6010	2
13	966542	Ball Bearing, 6207	1
14	967308	Bearing Cone & Cup, 30207	1
15	967309	Oil Seal, 50 x 80 x 10	2
16	967310	Oil Seal, 35 x 72 x 10	1
17	967312	Oil Plug, 3/8" Ga. 2, DIN 906	3
18	967313	Gear Set, R=1.46	1

**SHIPPING KIT AND BUNDLE NUMBERS**

The following is a list of Kit Numbers for this product and the Bundle Numbers, Descriptions and Quantities for each Kit.

**QUANTITY                      BUNDLE NO.                      DESCRIPTION**

**C2540    40" Tiller c/w slip clutch PTO**

1	F0852	Deck Assembly
1	F0356	PTO

**C2548    48" Tiller c/w slip clutch PTO**

1	F0853	Deck Assembly
1	F0356	PTO

**C2560    60" Tiller c/w slip clutch PTO**

1	F0854	Deck Assembly
1	F0356	PTO

**C2540S    40" Tiller c/w shear pin PTO**

1	F0852	Deck Assembly
1	F0357	PTO

**C2548S    48" Tiller c/w shear pin PTO**

1	F0853	Deck Assembly
1	F0357	PTO

**C2560S    60" Tiller c/w shear pin PTO**

1	F0854	Deck Assembly
1	F0357	PTO

**Options:**

The following is a list of options available for the Kits listed above.

902676            Adaptor kit (Cat. 1 to Cat. 0)



## DIVISION LOCATIONS

Farm King Division  
301 Mountain Street S.  
Morden, MB R6M 1X7  
Ph.: (204) 822-4467  
Fax: (204) 822-6348

Allied/Inland Division  
1260 Clarence Avenue  
Winnipeg, MB R3T 1T2  
Ph.: (204) 284-6100  
Fax: (204) 477-2325

B.I.I. Division  
1330 43<sup>rd</sup> Street N.W.  
Fargo, ND 58102  
Ph: (701) 282-7014  
Fax: (701) 282-5865

## U.S. WAREHOUSES

AR, West Memphis  
(870) 732-3132

GA, Stone Mountain  
(770) 908-9439

ID, Meridian  
(208) 887-6006

IN, Clarksville  
(812) 284-3376

KS, Wichita  
(316) 265-9577

MN, Lakeville  
(952) 469-5267

MT, Billings  
(406) 248-7771

ND, Bismarck  
(701) 223-1886

ND, Fargo  
(701) 282-7003

NE, Blair  
(402) 426-8211

OH, Youngstown  
(330) 793-0862

OR, Beaverton  
(503) 641-1865

SD, Huron  
(605) 352-8616

TX, Houston  
(713) 928-2632

UT, Salt Lake City  
(801) 972-4321

WI, Portage  
(608) 742-1370

## CANADIAN WAREHOUSES

B.C., Abbotsford  
(604) 864-2665

AB, Edmonton  
(780) 962-6991

SK, Regina  
(306) 781-2300

ON, Woodstock  
(519) 539-0435

QC, Dorion  
(450) 455-4840

## OFFSHORE WAREHOUSES

Burando Hill  
Katanning  
W. Australia  
011-618-98-214422

Chihuahua, Mexico  
011-52-158-90306

John Kerr Equipment Ltd.  
Wilcoxholm Farm  
Linlithgow, W. Lothian  
Scotland  
011-441-506-842280

Skovde, Sweden  
011-46-500-452651

Naestved, Denmark  
011-45-557-29511

# bühler

**Buhler Manufacturing**

**301 Mountain Street S.  
Morden MB.  
R6M 1X7  
Ph.: (204) 822-4467  
Fax: (204) 822-6348  
[www.buhler.com](http://www.buhler.com)**