

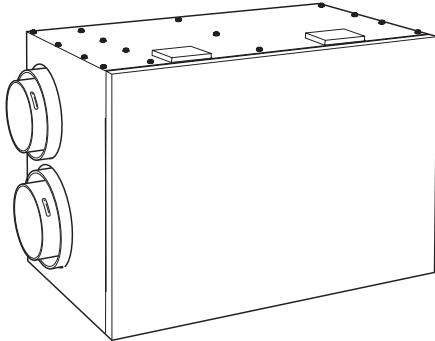

SINGLE-PACKAGE ELECTRIC HEATING COOLING UNITS

HRVBBLHU HRVBBSVC HRVBBLVU

Heat Recovery Ventilators



HRVBBLHU

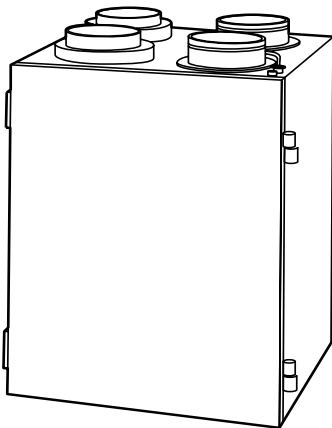

HRVBBSVC

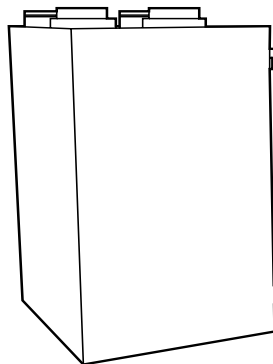

HRVBBLVU

The Heat Recovery Ventilation (HRV) system offered by Bryant is the finest unit on the market today.

The HRVB provides efficient and cost-effective heat recovery during the heating season when needed most.

As temperatures drop below 23°F (-5°C), indoor air is recirculated periodically through the heat exchanger core to prevent frost from forming. Competitors' methods of supplementary electric defrost waste energy. Unlike rotary wheel heat exchangers which mix air streams, these cross flow or counterflow heat exchangers ensure that there is no mixing of the stale air stream with the fresh outdoor air stream.

A filter installed on the incoming outdoor air stream removes large airborne particles from the intake air stream before they enter the heat exchanger and reduces the maintenance required.

The units' acoustically engineered design makes them the quietest on the market and ensures that comfort is felt, not heard.

Unlatching 2 suitcase style latches allows easy removal of the filters and core for cleaning.

FEATURES

- Energy saving defrost cycle
- Cross flow, counterflow heat exchangers
- Two filters on incoming outdoor air stream to protect the HRV core
- Acoustical design
- No-tools maintenance
- Polypropylene heat exchanger core

Model number nomenclature

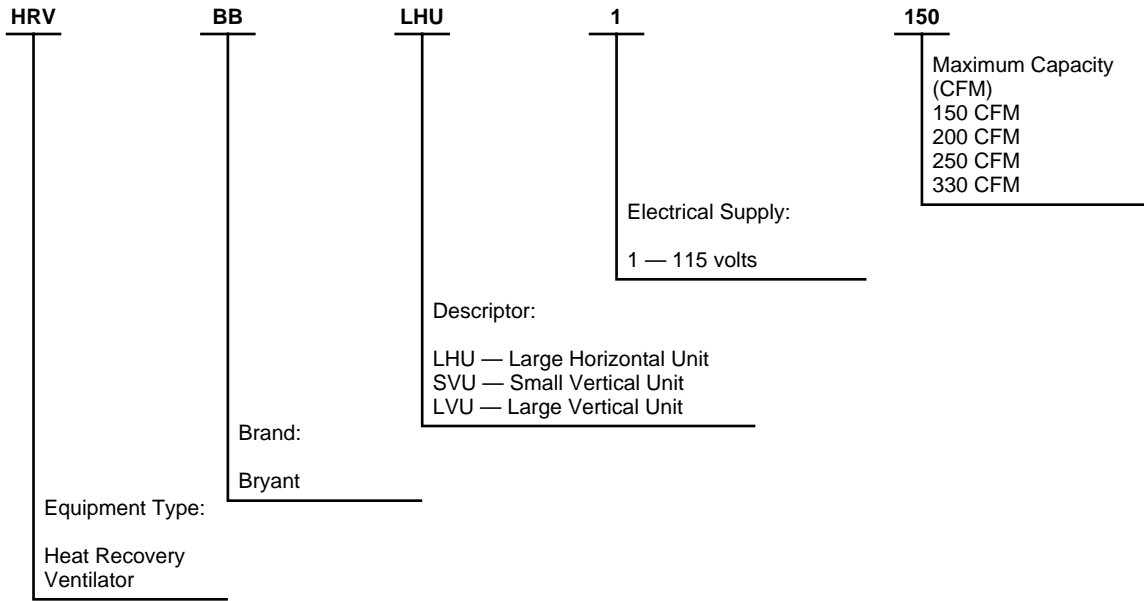

Climate Map for Energy and Heat Recovery Ventilators

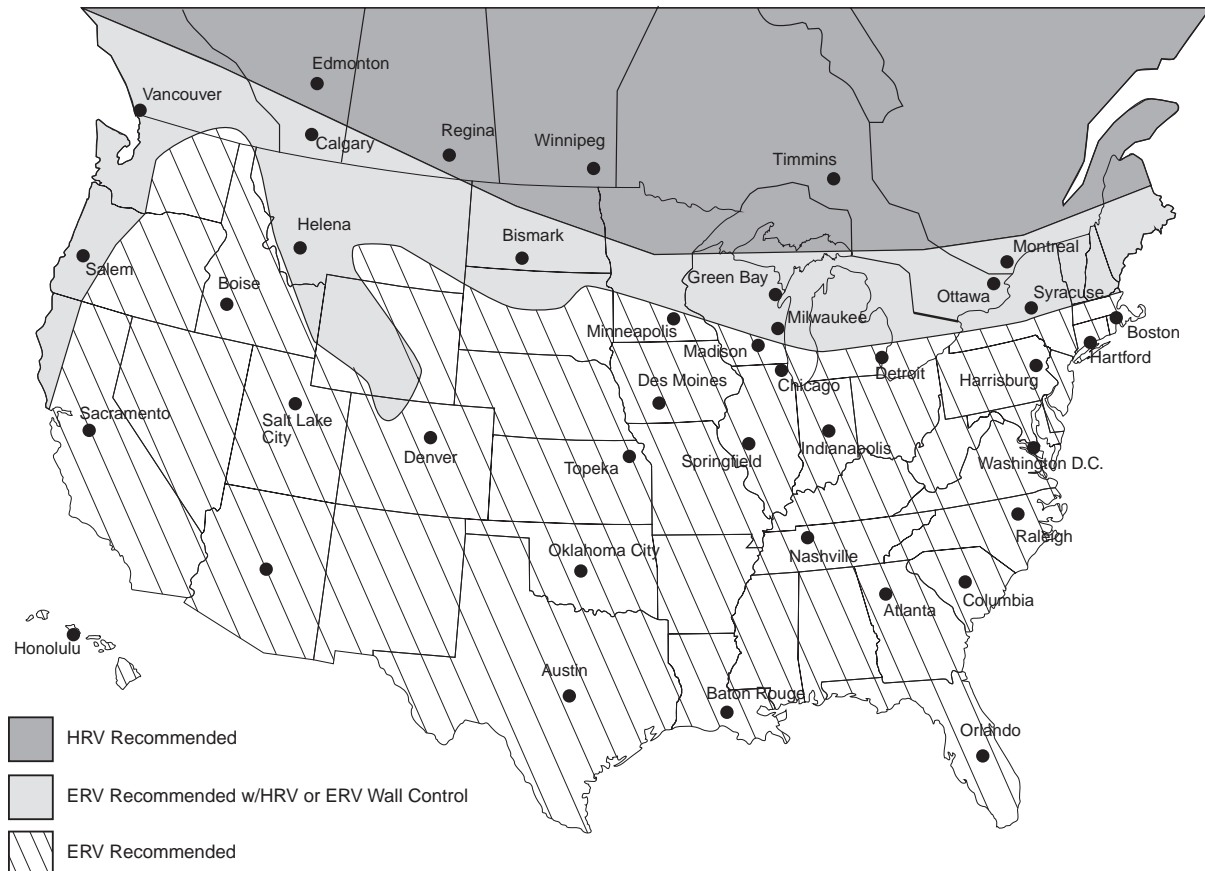

Controls and accessories part no. nomenclature

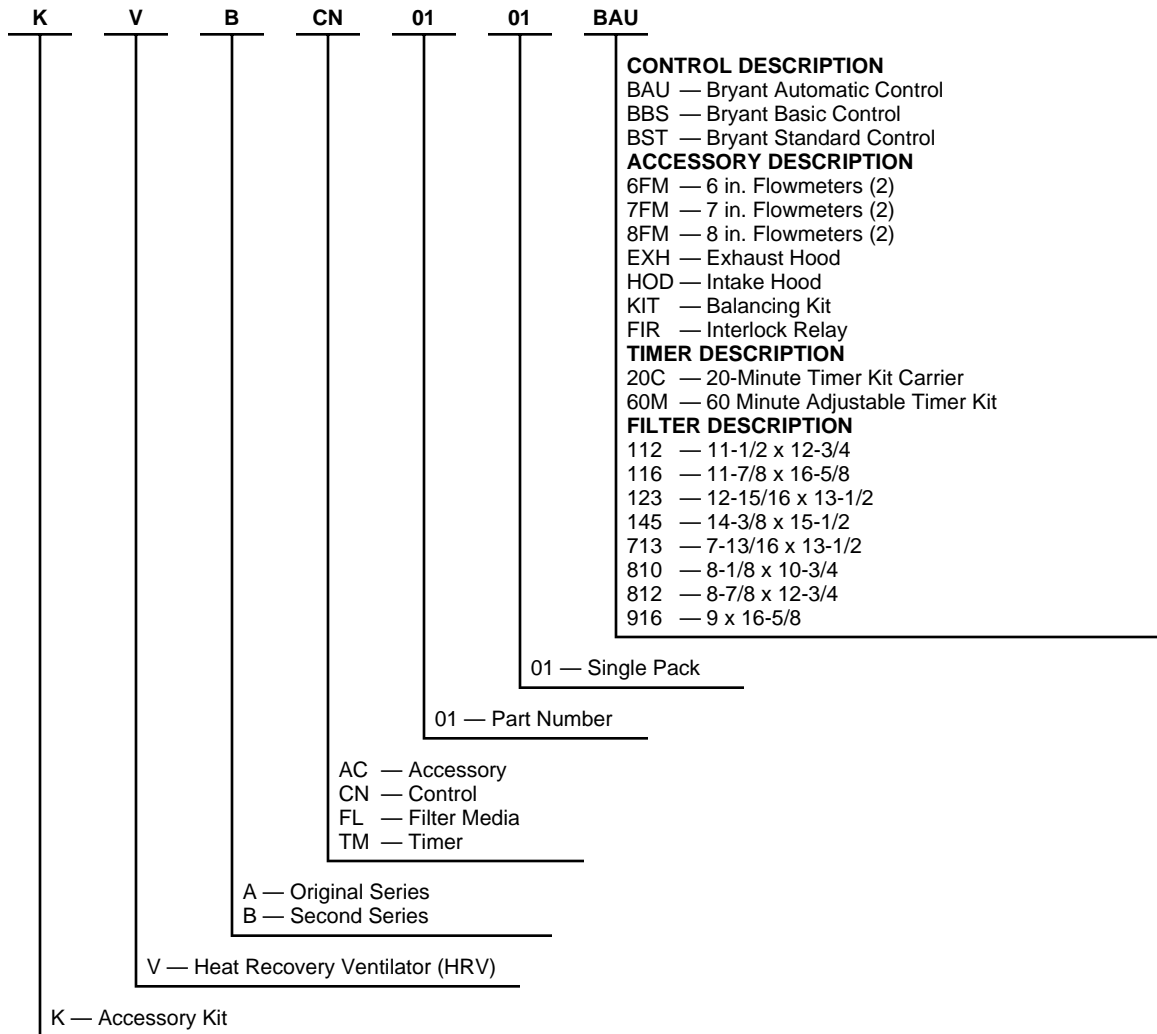

ACCESSORIES

Kit Number	Description	Where Used
KVBCN0101CBS	Basic HRV Control	Used with all HRVs
KVBCN0101CST	Standard HRV Control	Used with all HRVs
KVBCN0101CAU	Automatic HRV Control	HRVBLSVU, HRVBBLVU
KVAAC0101FIR	Interlock Relay	When combining an HRV with a Furnace or Fan Coil
KVATM010120C	20 Minute Push Button Timer	Used with all HRVs when 20 minute manual operation is required
KVATM010160M	60 Minute Timer	Used with all HRVs, time is adjustable between 10 and 60 minutes
KVAAC0101HOD	Exterior Intake and Exhaust Hood	2 Required
KVAAC0101KIT	Start up Balancing Kit	Start up Balancing Kit, includes (2) 6 in. Flow Meter Collars & Magnehelic Gage
KVAAC01016FM	6 in. Flow Meter Collar	At start up, when 6 in. duct work is connected to HRV
KVAAC01017FM	7 in. Flow Meter Collar	At start up, when 7 in. duct work is connected to HRV
KVAAC01018FM	8 in. Flow Meter Collar	At start up, when 8 in. duct work is connected to HRV
KVAFK0101150	Internal Filter	Used with HRVBBLHU 1150 Unit 11 3/4 x 12 7/8 x 3/4 (2)
KVAFK0201200	Internal Filter	Used with HRVBBLHU 1250 Unit 11 3/4 x 16 3/4 x 3/4 (2)
KVAFL0101713	Internal Filter	Used with HRVBBSVU 1150 Unit 7 13/16 x 13 1/2 (2)
KVAFL0101123	Internal Filter	Used with HRVBBSVU 1200 Unit 12 15/16 x 13 1/2 (2)
KVAFL0101123	Internal Filter	Used with HRVBBLVU 1200 Unit 12 15/16 x 13 1/2 (2)
KVAFL0101145	Internal Filter	Used with HRVBBLVU 1200 Unit 14 3/8 x 15 1/2
KVAFL0101810	Internal Filter	Used with HRVBBLVU 1330 Unit 8 1/8 x 10 3/4 (1)
KVAFL0101145	Internal Filter	Used with HRVBBLVU 1330 Unit 14 3/8 x 15 1/2 (1)
KVAFL0101810	Internal Filter	Used with HRVBBLVU 1200 Unit 8 1/8 x 10 3/4 (1)

CONTROL FEATURES

Basic Control: Allows the user to manually set fan speed to low or high as required to maximize comfort.

Standard Control: Offers automatic dehumidistat control and the option to select continuous or intermittent fan operation. Setting the wall control to low will activate the continuous mode.

Automatic Control: In addition to the features found with standard control, this package offers a recirculation mode. These controls may only be used to operate stand-alone units with the defrost option which enables the recirculation feature.

CONTROL DESCRIPTION	FAN SPEED CONTROL	DEHUMIDISTAT CONTROL	CONTINUOUS MODE*	INTERMITTENT MODE*	CIRCULATION MODE†
Basic	Yes	No	Yes	No	No
Standard	Yes	Yes	Yes	Yes	No
Automatic‡	Yes	Yes	Yes	Yes	Yes

* Air exchange with outside.

† No air exchange with outside.

‡ Use only on units with defrost.

CONTROL DESCRIPTION AND USAGE

Fan Speed Control — Enables user to modulate fan speed from low to high air exchange with outside.

Dehumidistat Control — Allows the user to select the relative humidity level at which the unit would change fan speed for dehumidification in the winter months.

Continuous Mode — If the relative humidity inside the building is lower than selected, air exchange occurs with the outside at low speed. If the relative humidity inside the house is higher than selected, air exchange occurs with the outside at high speed. Ensures continuous air exchange for constant air quality.

Intermittent Mode — If the relative humidity inside the building is lower than selected, no air exchange occurs and the system turns off. If the relative humidity inside the house is higher than selected, air exchange occurs with the outside at high speed. Ensures minimum air exchange level when the building is unoccupied to minimize operating costs.

Circulation Mode — If the relative humidity inside the building is lower than selected, the ambient air would be circulated and filtered at high speed. If the relative humidity inside the house is higher than selected, air exchange would occur with the outside at high speed. Ensures continuous movement and filtration of air for maximum comfort. Available with automatic control only.

AUTOMATIC DEFROST CYCLE FEATURES

All models offer a non-electric defrost cycle feature which prevents frost and ice buildup within the heat recovery core. When the outside air temperature falls below 23°F (–5°C) it is electronically sensed and the dampers close the outside air ports. This allows warm indoor air to recirculate within the heat recovery core. The frequency of this cycle increases as the outside air temperature decreases.

MODEL	23°F TO 55°F (–5°C TO –15°C)		4°F TO –17°F (–15.6°C TO –27.3°C)		BELOW –18°F (–27.8°C)	
	DEFROST*	EXCHANGE†	DEFROST*	EXCHANGE†	DEFROST*	EXCHANGE†
HRVBBLHU	6 Minutes	60 Minutes	6 Minutes	32 Minutes	6 Minutes	20 Minutes
HRVBBSVU	6 Minutes	60 Minutes	6 Minutes	32 Minutes	6 Minutes	20 Minutes
HRVBBLVU	6 Minutes	60 Minutes	6 Minutes	32 Minutes	6 Minutes	20 Minutes

* All defrost times are in the standard mode (as shipped)

† Time between defrost when within specified temperature range

DIMENSIONS

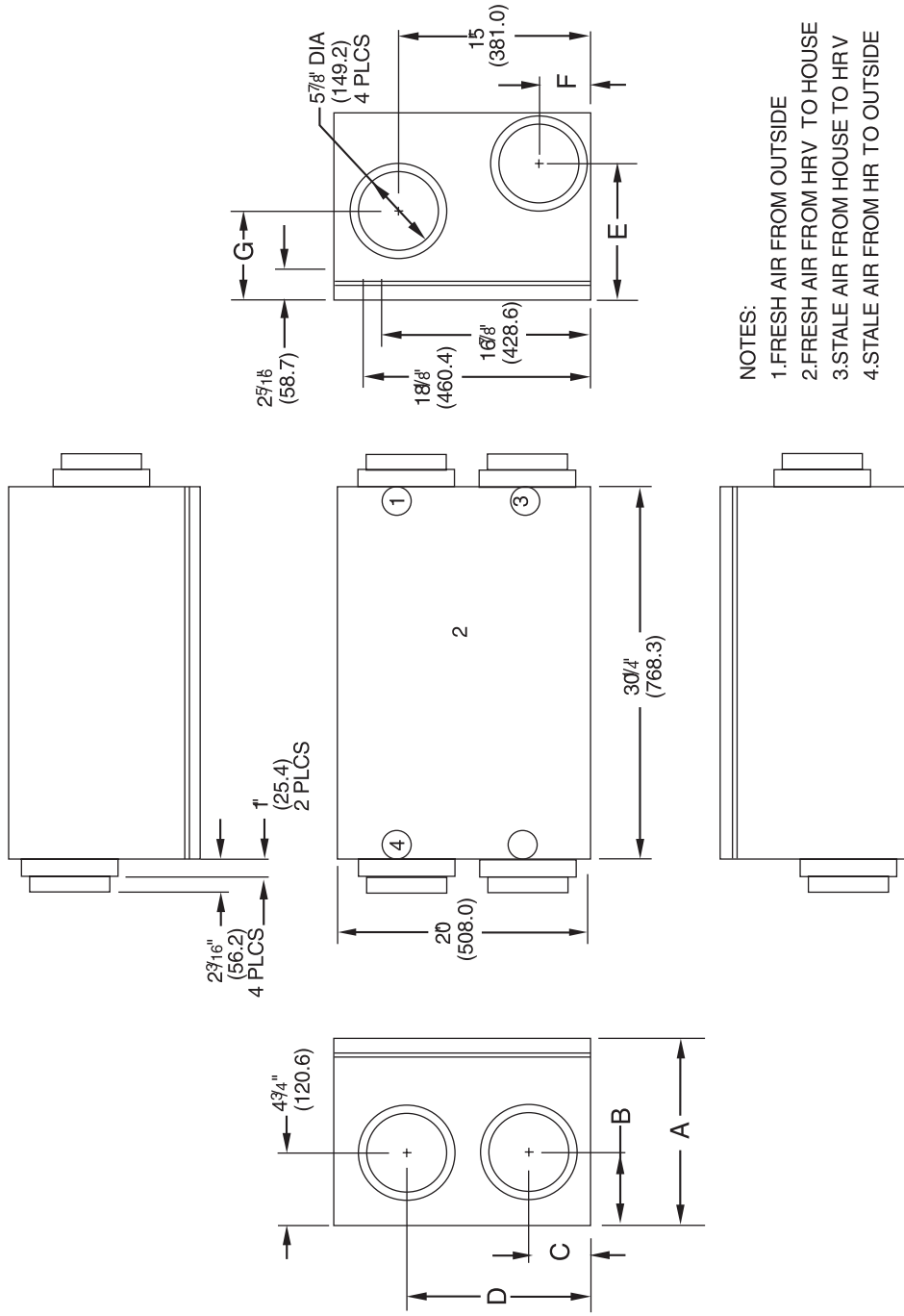

A98002

MODEL NO.	A		B		C		D		E		F		G	
	in.	mm	in.	mm	in.	mm	in.	mm	in.	mm	in.	mm	in.	mm
HRVBBLHU1150	15-1/8	384.2	4-1/16	104	5/58	143.3	14-1/2	368.9	10-3/8	288.9	4-3/8	111.3	7-3/4	196.9
HRVBBLHU1250	19	483	5-13/16	147.7	5-1/16	128.1	14-1/2	368.9	11-3/16	283.9	4-3/8	111.3	10-1/16	255.6

DIMENSIONS (continued)

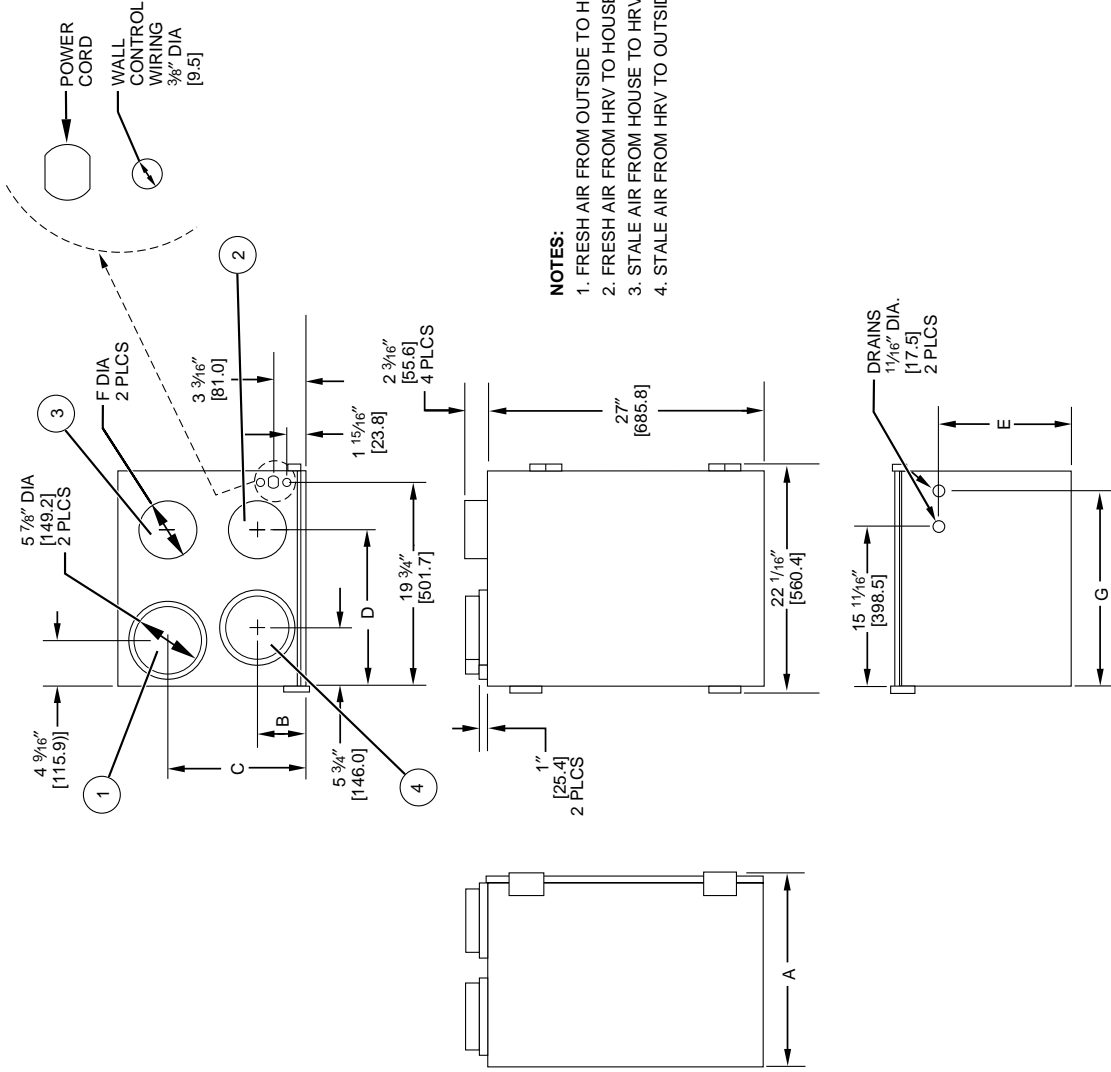

MODEL NO.	A		B		C		D		E		F		G	
	in.	mm	in.	mm	in.	mm	in.	mm	in.	mm	in.	mm	in.	mm
HRVBSVU1150	18-1/2	469.9	4-11/16	119.1	13-5/16	388.2	15-7/16	392.1	13-9/16	344.5	5-7/8	149.2	19-15/16	506.2
HRVBSVU1200	24-1/2	622.2	8-3/16	208.0	19-5/16	490.6	14-9/16	369.9	16-15/16	430.2	6-7/8	174.6	19-15/16	506.2

DIMENSIONS (continued)

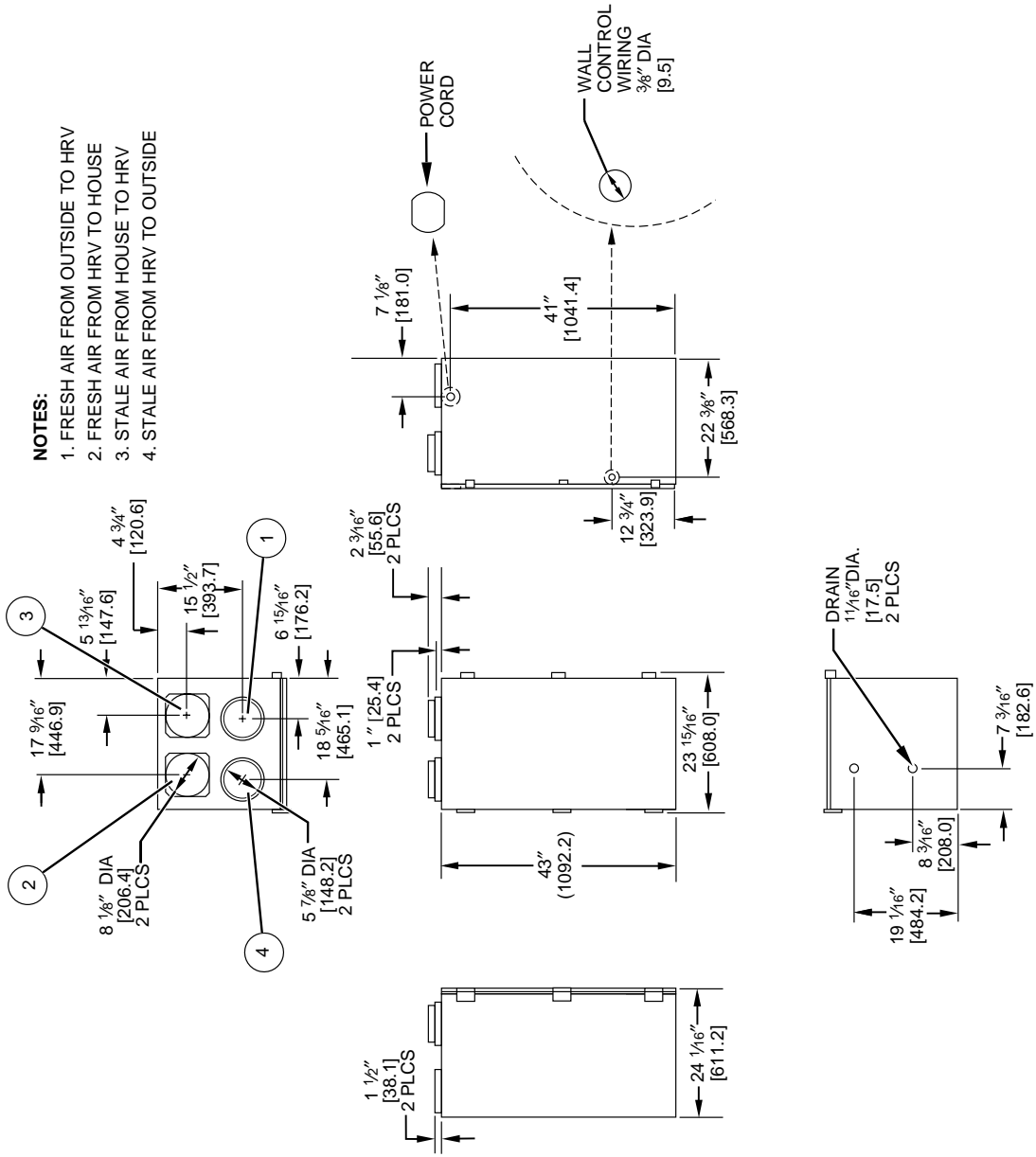

HRVBBLVU1200 or HRVBBLVU1330

PHYSICAL DATA

MODEL DESCRIPTION	CONVENTIONAL		COMPACT		HIGH EFFICIENCY		
Model No.	HRVBBVHU1150	HRVBBVHU1260	HRVBBSVC1150	HRVBBSVC1200	HRUBBLVU1150	HRUBBLVU1200	HRUBBLVU1330
Port Locations	Sides	Sides	Top	Top	Top	Top	Top
Core Type	Polypropylene Cross Flow	Polypropylene Cross Flow	Polypropylene Cross Flow	Polypropylene Cross Flow	Polypropylene Cross Flow	Polypropylene Counterflow	Polypropylene Counterflow
Weight — lb (kg)	65 (29.5)	73 (33.2)	60 (27)	80 (36.3)	80 (36.3)	120 (54.5)	120 (54.5)
Shipping Weight — lb (kg)	75 (34)	83 (37.6)	75 (34)	89 (40.4)	89 (40.4)	143 (64.9)	143 (64.9)
Shipping Dimensions (in.)							
Height	23 1/16	22 15/16	31.5	31.5	31.5	47.5	47.5
Width	36 1/16	35 1/16	23.25	23.25	23.25	26.0	26.0
Depth	17 13/16	22 5/16	26.00	26.00	26.00	26.0	26.0

PERFORMANCE DATA

MODEL DESCRIPTION	CONVENTIONAL		COMPACT		HIGH EFFICIENCY		
Model No.	HRVBBLHU1150	HRVBBLHU1250	HRVBBSVC1150	HRVBBSVC1200	HRVBBLVU1150	HRVBBLVU1200	HRVBBLVU1330
Capacity — CFM @ 0.5–0.3ESP (in. wc)	130–168	191–210	106–150	177–211	123–141	189–209	300–334
Efficiency (Sensible) — percent							
32°F (0°C)	65	65	69	77	81	84	80
–13°F (–25°C)	65	60	60	67	69	72	74
Efficiency (Latent) — percent @ all temperatures	0	0	0	0	0	0	0
Heat Core Exchange Area — cu ft (cu m)	120 3.4	166 4.7	90 8.4	144 13.3	144 13.3	210 19.5	210 19.5

ELECTRICAL DATA

	CONVENTIONAL		COMPACT		HIGH EFFICIENCY		
Model	HRVBBLHU1150	HRVBBLHU1250	HRVBBSVC1150	HRVBBSVC1200	HRVBBLVU1150	HRVBBLVU1200	HRVBBLVU1330
Voltage	120	120	120	120	120	120	120
Max Power — watts	150	218	115	195	115	250	500
Max Amps	1.4	1.9	1.2	1.8	1.2	2.2	5.4

METHODS TO SIZE HRV'S

METHOD 1

1. Calculate cu ft of occupied space.
2. Multiply by recommended air changes per hr (AC/h).
3. Divide by 60 minutes per hr to convert to CFM.

EXAMPLE: 2000 sq ft with 8 ft ceiling
0.35 air changes per hr (AC/h)

$$(2000 \text{ sq ft} \times 8 \text{ ft ceiling} \times 0.35 \text{ AC/h}) / 60 \text{ min/h} = 93.3 \text{ CFM}$$

METHOD 2

1. Multiply number of people times 15 CFM/person.
2. Multiply number of bath rooms 20 CFM/each.
3. Add 25 CFM for kitchen.

EXAMPLE: 2 people
2 baths
1 kitchen

$$(2 \times 15) + (2 \times 20) + 25 = 95 \text{ CFM}$$

ADDITIONAL HEATING AND COOLING LOAD CHARTS

Although the ventilators process the outside air before it enters the home, additional heating and cooling loads need to be considered.

HEATING LOAD BTU

Outside Temp °F	Heat Load (Btuh) @ Inside Design Temp 72°F						
	HRVBBLHU1150	HRVBBSVC1250	HRVBBSVC1150	HRVBBSVC1200	HRVBBLVU1150	HRVBBLVU1200	HRVBBLVU1330
-25	4,688	8,165	6,970	7,690	5,500	6,650	9,990
-20	4,466	7,744	6,470	7,090	5,030	6,070	9,310
-15	4,598	8,008	5,990	6,520	4,590	5,510	8,650
-10	4,334	7,547	5,520	5,970	4,160	4,970	8,000
-5	4,069	7,087	5,070	5,440	3,750	4,470	7,380
0	3,805	6,627	4,550	4,840	3,300	3,910	6,640
5	3,541	6,167	4,130	4,360	2,940	3,470	6,060
10	3,502	6,100	3,730	3,900	2,600	3,050	5,500
15	3,220	5,608	3,290	3,400	2,240	2,600	4,870
20	2,938	5,116	2,930	3,000	1,940	2,240	4,350
25	2,950	5,138	2,580	2,610	1,670	1,910	3,850
30	2,636	4,591	2,240	2,250	1,410	1,600	3,370
35	2,322	4,045	1,900	1,880	1,160	1,300	2,870
40	2,009	3,498	1,600	1,560	940	1,040	2,430

The heating load chart shows the heating loads in Btuh for a range of winter design temperatures for each model of ventilator.

EXAMPLE: The heating design temperature for Milwaukee, WI is -4°F. At -5°F, the additional heating load of the HRVBBLHU1250 is 8417 Btuh. This additional load should be taken into consideration when sizing the heating equipment.

COOLING LOAD BTU

Outside Enthalpy Btu/lb	Cooling Load (Btuh) @ Inside Design Temp 75°F and 50% Relative Humidity						
	HRVBBLHU1150	HRVBBLHU1250	HRVBBSVC1150	HRVBBSVC1200	HRVBBLVU1150	HRVBBLVU1200	HRVBBLVU1330
30	670	1,071	780	990	770	990	1,390
31	1,090	1,741	1,300	1,650	1,290	1,650	2,310
32	1,509	2,411	1,820	2,310	1,800	2,310	3,240
33	1,928	3,080	2,340	2,970	2,310	2,970	4,170
34	2,347	3,750	2,860	3,630	2,830	3,630	5,090
35	2,766	4,419	3,380	4,290	3,340	4,290	6,020
36	3,185	5,089	3,910	4,950	3,860	4,950	6,940
37	3,604	5,759	4,430	5,610	4,370	5,610	7,870
38	4,023	6,428	4,950	6,270	4,890	6,270	8,790
39	4,442	7,098	5,470	6,930	5,400	6,930	9,720
40	4,861	7,767	5,990	7,590	5,910	7,590	10,650
41	5,280	8,437	6,510	8,250	6,430	8,250	11,570
42	5,699	9,107	7,030	8,910	6,940	8,910	12,500

The cooling load chart shows loads in Btuh as well. To use the cooling load chart, first find the design enthalpy from a psychrometric chart using the design dry bulb and wet bulb temperatures. (See psychrometric chart on p. 11.) The cooling load can then be found for a range of enthalpies for each ventilator.

EXAMPLE: The cooling design dry bulb temperature for Milwaukee, WI is 87°F and the average wet bulb at that temperature is 73°F. On the psychrometric chart the enthalpy is about 37.7 Btu/lb of dry air which will round up to 38 Btu/lb of dry air. In the left column, at 38 Btu/lb the HRVBBLHU1250 would have an additional cooling load of 6428 Btuh. This additional load should be taken into account when sizing the air cooling equipment.

PSYCHROMETRIC CHART

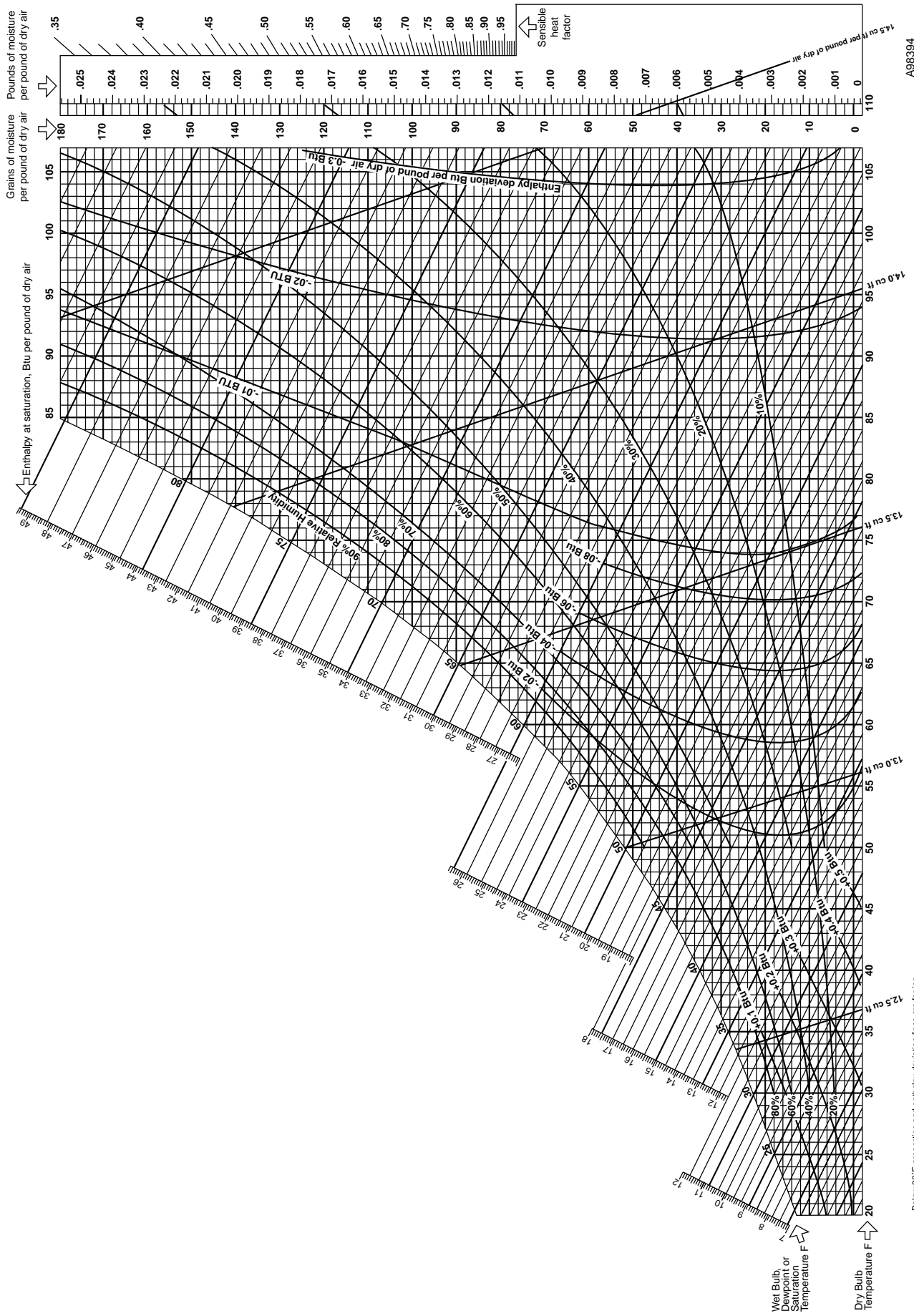

Below 32 F, properties and enthalpy deviation lines are for ice.

A98394

HRV INSTALLED WITH FORCED AIR SYSTEM

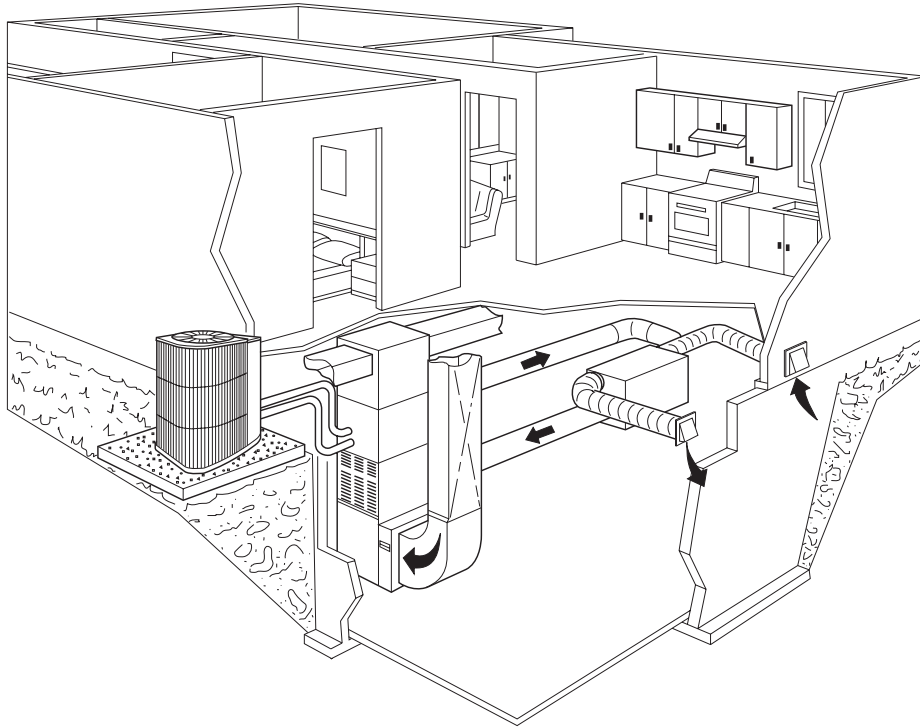

A99297

HRV INSTALLED WITH INDEPENDENT AIR DISTRIBUTION

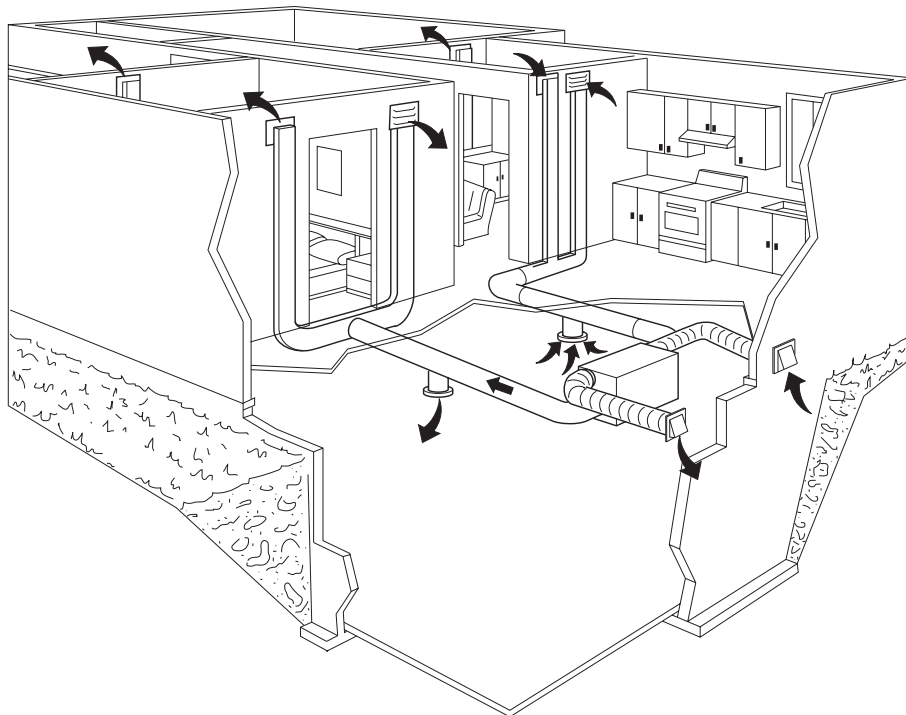

A99298

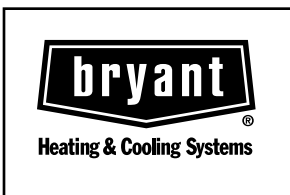

SPECIFICATIONS SUBJECT TO CHANGE WITHOUT NOTICE

UNIT MUST BE INSTALLED IN ACCORDANCE
WITH INSTALLATION INSTRUCTIONS

Cancels: New

FORM PDS HRV.71.1