



user's information manual

582A
Sizes 018-060

SINGLE-PACKAGED GAS HEATING/ELECTRIC COOLING

583A
Sizes 024-060

Cancels: OM10-17

OM10-22
1/1/03

NOTE TO INSTALLER

This manual should be left with the equipment owner.

FOR YOUR SAFETY

Do not store or use gasoline or other flammable vapors and liquids in the vicinity of this or any other appliance.

⚠ WARNING: Improper installation, adjustment, alteration, service or maintenance can cause injury or property damage. Refer to this manual. For assistance or additional information, consult a qualified installer, service agency, or the gas supplier.

FOR YOUR SAFETY

WHAT TO DO IF YOU SMELL GAS

- Do not try to light any appliance.
- Do not touch any electrical switch; do not use any phone in your building.
- Immediately call your gas supplier from a neighbor's phone. Follow the gas supplier's instructions.
- If you cannot reach your gas supplier, call the fire department.

⚠ WARNING: Before performing recommended maintenance, be sure gas supply and main power switch to unit are turned off. Electrical shock could cause personal injury.

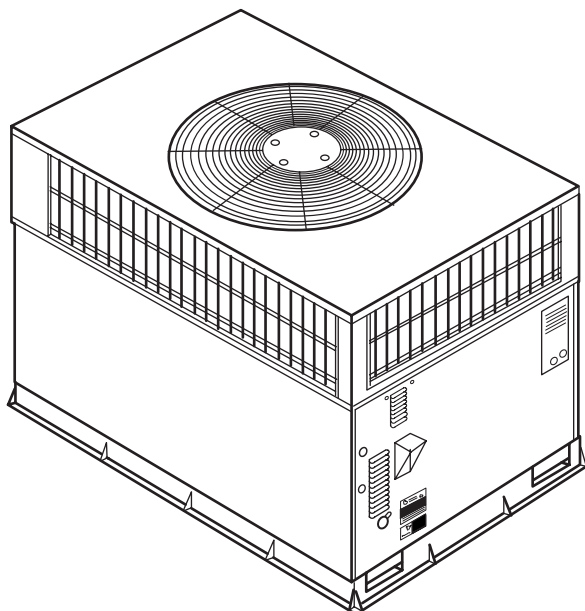

Model 582A with Standard Wire Grille

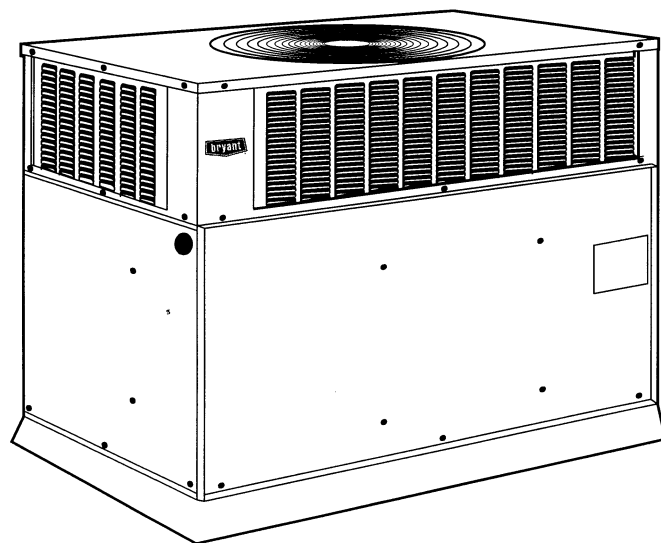

Model 583A with Optional Louvered Grille

Your combination heating/cooling unit is equipped with an automatic direct spark ignition and power combustion blower.

⚠ WARNING: Do not attempt to light by hand; personal injury may result.

TO LIGHT UNIT

⚠ DANGER:

1. Do not turn off the electrical power to unit without first turning off the gas supply.
2. Before attempting to start the gas heating section, familiarize yourself with all the procedures that must be followed.

If you do not follow these instructions exactly, a fire or explosion may result, causing property damage, injury, or loss of life.

Refer to Fig. 1. See Fig. 2 for location of gas valve. Refer to Fig. 3 while proceeding with the following steps.

I. Step 1

Set the temperature selector on room thermostat to the lowest temperature setting and set system switch to HEAT.

II. Step 2

Close the external manual shutoff valve.

III. Step 3

Turn off the electrical supply to the unit.

IV. Step 4

Remove the front access panel with a $\frac{5}{16}$ -in. nut driver.

V. Step 5

Move the selector switch on the internal gas valve to the OFF position and wait 5 minutes.

VI. Step 6

Move the selector switch on the internal gas valve to the ON position.

VII. Step 7

Replace the front access panel.

VIII. Step 8

Turn on the electrical supply to unit.

IX. Step 9

Open the external manual shutoff valve.

X. Step 10

Set the temperature selector on room thermostat slightly above room temperature to start unit. The induced-draft combustion-air fan will start. Main gas valve will open and main burners should ignite within 5 seconds. If the burner does not light within 5 seconds, the ignition module will go into a Retry mode after a period of approximately 22 seconds (following the 5-second ignition period).

If the burners do not light within 15 minutes of the initial call for heat, there is a lockout.

XI. Step 11

Set the temperature selector on room thermostat to desired setting.

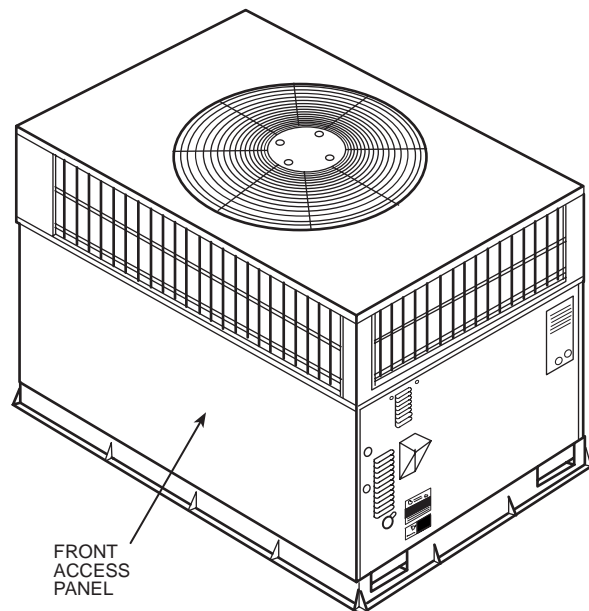

Fig. 1 — Gas Heating/Electric Cooling Unit

⚠ WARNING:

1. If the main burners fail to light, or the blower fails to start, shut down gas heating section and call your dealer for service.
2. Never attempt to manually light the main burners on unit with a match, lighter, or any other flame. If the electric sparking device fails to light the main burners, refer to the following shutdown procedures, then call your dealer as soon as possible.

Failure to follow these requirements could result in serious personal injury.

TO SHUT UNIT OFF

⚠ WARNING: Do not turn off the electrical power to unit without first turning off the gas supply.

Failure to follow these procedures can result in serious fire or personal injury.

NOTE: If unit is being shut down because the heating season has ended, make sure to turn on power to cooling system.

If unit is being shut down because of a malfunction, call your dealer as soon as possible.

Should overheating occur or the gas supply fail to shut off, shut off the manual gas valve to the unit before shutting off the electrical supply.

Do not use this unit if any part has been under water. Immediately call a qualified service technician to inspect the unit and to replace any part of the control system and any gas control which has been under water.

Refer to Fig. 4 while proceeding with the following steps.

I. Step 1

Set the temperature selector on room thermostat to lowest temperature setting and set system switch to OFF.

II. Step 2

Close the external manual shutoff valve.

III. Step 3

Turn off the electrical power supply to the unit.

IV. Step 4

Remove the front access panel.

V. Step 5

Move the selector switch on the internal gas valve to the OFF position.

VI. Step 6

Replace the front access panel.

VII. Step 7

Restore electrical power to the unit and set system switch to COOL to ensure operation of the cooling system during the cooling season.

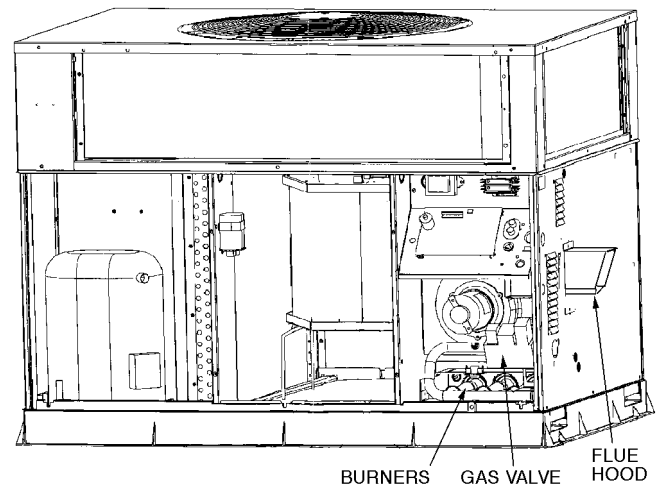

Fig. 2 — Gas Heating/Electric Cooling Unit (Internal View)

ROUTINE MAINTENANCE

All routine maintenance should be handled by skilled, experienced personnel. Your dealer can help you establish a standard procedure.

For your safety, keep the unit area clear and free of combustible materials, gasoline, and other flammable liquids and vapors.

To assure proper functioning of the unit, flow of combustion and ventilating air must not be obstructed from reaching the unit. Clearance of at least 30 in. is required on all sides except the duct side.

MAINTENANCE AND CARE FOR THE EQUIPMENT OWNER

Before proceeding with those things you might want to maintain yourself, please carefully consider the following:

⚠ WARNING:

1. TURN OFF GAS SUPPLY AND ELECTRICAL POWER TO YOUR UNIT BEFORE SERVICING OR PERFORMING MAINTENANCE.
2. Do not turn off electrical power to this unit without first turning off the gas supply.
3. When removing access panels or performing maintenance functions inside your unit, be aware of sharp sheet metal parts and screws. Although special care is taken to reduce sharp edges to a minimum, be extremely careful when handling parts or reaching into the unit.

I. Air Filters

Air filter(s) should be checked at least every 3 or 4 weeks and changed or cleaned whenever it becomes dirty. Dirty filters produce excessive stress on the blower motor and can cause the motor to overheat and shut down. Table 1 indicates the correct filter size for your unit. Refer to Fig. 5 to access the filter(s).

To replace or inspect filter(s) (or accessory filter rack when supplied):

1. Remove the filter access panel using a 5/16-in. nut driver.
2. Remove the filter(s) by pulling the filter(s) out of the unit.
If the filter(s) is dirty, clean or replace with new one.

When installing the new filter(s), note the direction of the air-flow arrows on the filter frame.

If you have difficulty in locating your air filter(s), or if you have questions concerning proper filter maintenance, contact your dealer for instructions. When replacing filters, always use the same size and type of filter that was supplied originally by the installer.

Table 1 — Indoor-Air Filter Data*

UNIT SIZE	FILTER SIZE
582A018-030	20x24
582A036-042	20x24
582A048-060	24x30
583A024-030	20x20
583A036	20x24
583A042-060	24x30

*For filter grille installations only.

⚠ WARNING: Never operate your unit without filters in place. Failure to heed this warning may result in damage to the blower motor and/or compressor. An accumulation of dust and lint on internal parts of your unit can cause loss of efficiency and, in some cases, fire.

II. Heat Exchanger

To ensure dependable and efficient heating operation, the heat exchanger should be checked by a qualified maintenance person before each heating season, and cleaned when necessary. This checkout should not be attempted by anyone not having the required expertise and equipment to properly do the job. Checking and/or cleaning the heat exchanger involves removing the gas controls assembly and the flue collector box cover and, when completed, reinstalling the gas controls assembly for proper operation. Also, the flue collector box cover must be replaced correctly so that a proper seal is maintained. Contact your dealer for the required periodic maintenance.

III. Fans and Fan Motor

Periodically check the condition of fan wheels and housings and fan-motor shaft bearings. No lubrication of condenser- or evaporator-fan bearings or motors is required or recommended.

IV. Evaporator and Condenser Coils

Cleaning of the coils should only be done by qualified service personnel. Contact your dealer for the required annual maintenance.

V. Condensate Drain

The drain pan and condensate drain line should be checked and cleaned at the same time the cooling coils are checked by your dealer.

VI. Compressor

All compressors are factory-shipped with a normal charge of the correct type refrigeration grade oil in them and should rarely require additional oil. The service person must be certain the proper oil level is maintained in the compressor when it is installed and running.

VII. Condenser Fan

 **WARNING:** Do not poke sticks, screwdrivers, or any other object into revolving fan blades. Severe bodily injury may result.

The fan must be kept free of all obstructions to ensure proper cooling. Contact your dealer for any required service.

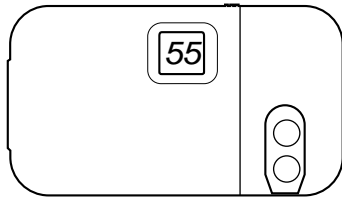

STEP 1

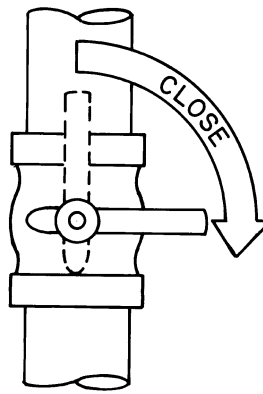

STEP 2

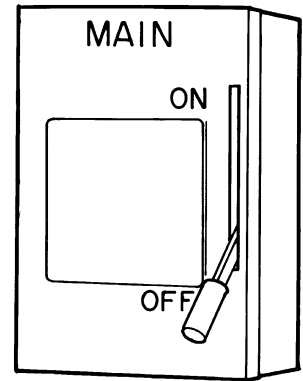

STEP 3

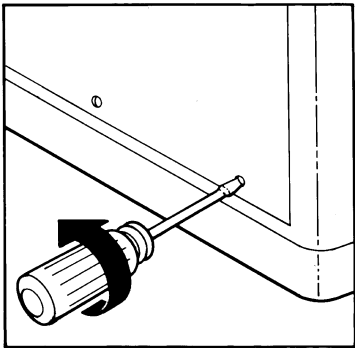

STEP 4

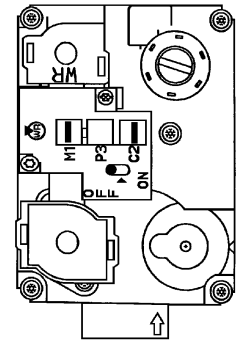
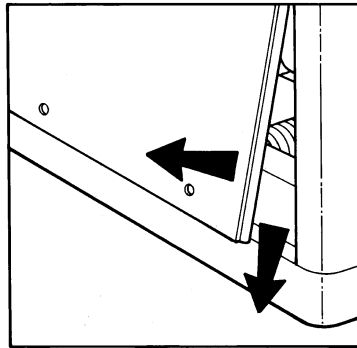

STEP 5

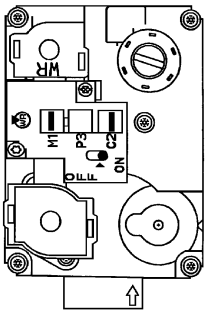

STEP 6

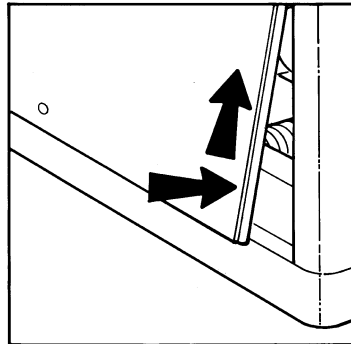

STEP 7

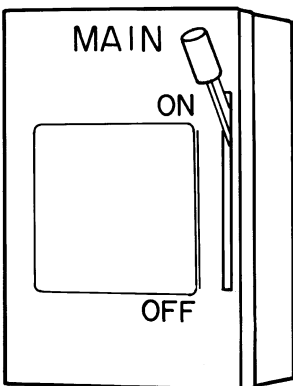
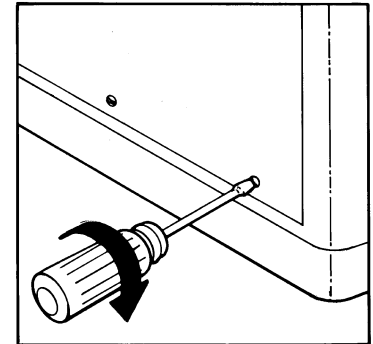

STEP 8

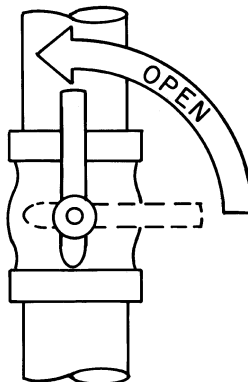

STEP 9

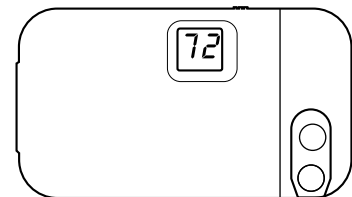

STEP 10

Fig. 3 — To Light Unit

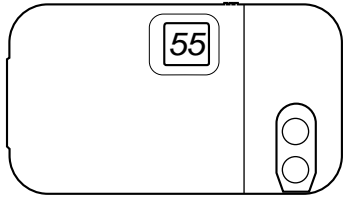

STEP 1

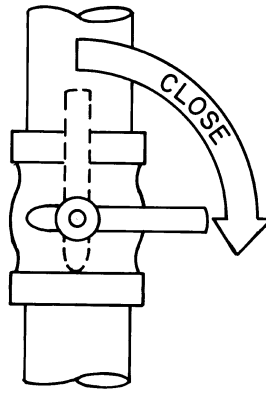

STEP 2

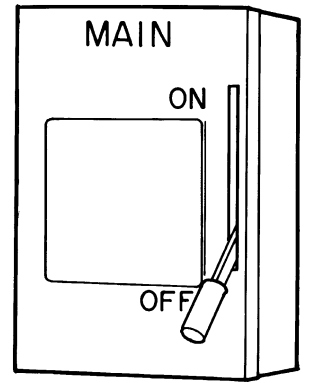

STEP 3

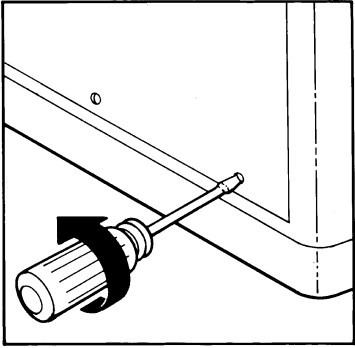

STEP 4

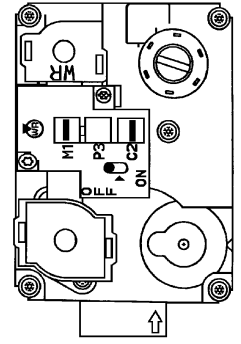
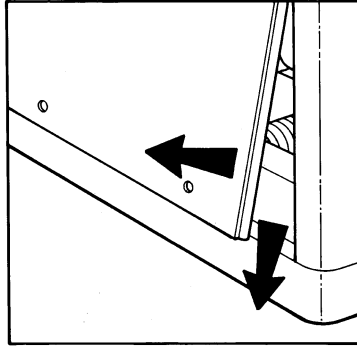

STEP 5

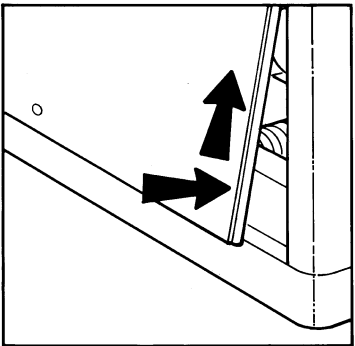

STEP 6

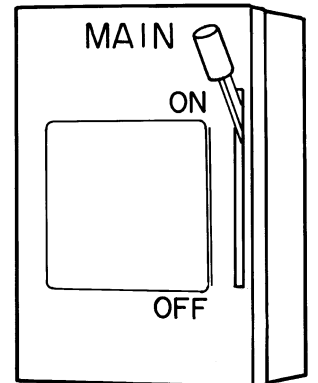
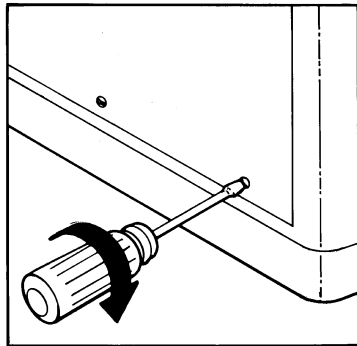

STEP 7

Fig. 4 — To Shut Unit Off

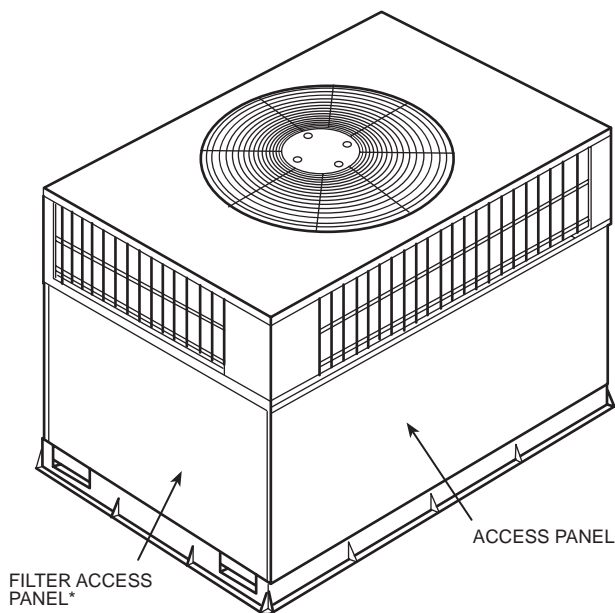

*For accessory filter rack.

Fig. 5 — Filter Access Panel — Vertical Supply Shown

VIII. Electrical Controls and Wiring

Electrical controls are difficult to check without proper instrumentation; therefore, if there are any discrepancies in the operating cycle, contact your dealer and request service.

IX. Refrigerant Circuit

The refrigerant circuit is difficult to check for leaks without the proper equipment; therefore, if inadequate cooling is suspected, contact your local dealer for service.

X. Combustion Area and Vent System

The combustion area and vent system should be inspected visually before each heating season. The normal accumulation of dirt, soot, rust, and scale can result in loss of efficiency and improper performance if allowed to build up.

⚠ CAUTION: If your unit makes an especially loud noise when the main burners are ignited, shut down the heating section and call your dealer.

Proceed as follows to inspect the combustion area and power-venting system of your unit.

1. Turn off electrical power and gas supply to your unit.
2. Remove burner access panel. (See Fig. 1.)
3. Using a flashlight, carefully inspect the burner areas for dirt, soot, rust, or scale. See Fig. 2.

⚠ CAUTION: If dirt, soot, rust, or scale accumulations are found, call your dealer and do not operate your heating section.

4. When you have completed your inspection, follow the start-up procedures in this manual to restore your unit to operation.
5. Observe unit heating operation.

⚠ WARNING: Components in heat section may be hot after unit has been started up. When observing flame, be careful not to get close to or touch heating components or serious personal injury may result.

Watch the burner flame to see if it is bright blue. If you observe a suspected malfunction or if the burner flames are not bright blue, call your dealer.

6. Replace burner access panel.

XI. Unit Panels

After performing any maintenance or service on the unit, be sure all panels are fastened securely in place to prevent rain from entering unit cabinet and to prevent disruption of the correct unit airflow pattern.

REGULAR DEALER MAINTENANCE

In addition to the type of routine maintenance you might be willing to perform, your unit should be inspected regularly by a properly trained service technician. An inspection (preferably each year, but at least every other year) should include the following:

1. Inspection of all flue product passages — including the burners, heat exchanger, and flue collector box.
2. Inspection of all combustion- and ventilation-air passages and openings.
3. Close inspection of all gas pipes leading to and inside of your unit.
4. Inspection and, if required, cleaning of the condenser and evaporator coils.
5. Inspection and, if required, cleaning of the evaporator drain pan.
6. Inspection and cleaning of blower wheel housing and motor.
7. Inspection of all supply-air and return-air ducts for leaks, obstructions, and insulation integrity. Any problems found should be resolved at this time.
8. Inspection of the unit base to ensure that no cracks, gaps, etc., exist which may cause a hazardous condition.
9. Inspection of the unit casing for signs of deterioration.
10. Inspection of all electrical wiring and components to assure proper connection.
11. Inspection for leaks in the refrigerant circuit. Pressure-check to determine appropriate refrigerant charge.
12. Inspection of compressor oil level.
13. Operational check of the unit to determine working conditions. Repair or adjustment should be made at this time.

Your servicing dealer may offer an economical service contract that covers seasonal inspections. Ask for further details.

Complete service instructions can be found in the unit Installation, Start-Up and Service Instructions.

WARRANTIES

Units 582A and 583A have warranties located at the back of this book. Be sure to read the warranty carefully to determine the coverage for your unit.

**BEFORE YOU CALL FOR SERVICE,
CHECK FOR SEVERAL EASILY SOLVED
PROBLEMS**

If insufficient heating or cooling is suspected:

() Check for sufficient airflow. Check the air filter for dirt. Check for blocked return-air or supply-air grilles. Be sure they are open and unobstructed. If these checks do not reveal the cause, call your servicing dealer.

If your unit is not operating at all, check the following list for easy solutions:

() Check to be sure that your thermostat temperature selector is set above the indoor temperature during the heating season, or below the indoor temperature during the cooling season. Be sure the system switch is in the proper HEAT or COOL position and not in the OFF position.

() Is the electrical supply switch ON? Are any fuses blown, or has the circuit breaker tripped?

() During the heating season, check the external manual shutoff valve. Is this lever parallel with the pipe, indicating that the valve is open? Or is the lever at a right angle, indicating that the valve is closed? If closed, has the gas been shut off for safety reasons? Otherwise, you may open the valve and follow the start-up procedures listed in this manual.

NOTE: Before proceeding with the next check, turn OFF the gas supply, then the electrical power supply to the unit. Remove the control access door.

() During the heating season, check the control dial on the internal gas valve. Is it in the ON position? If it is not, be sure it was not turned off for the purpose of safety. If no safety hazards exist, follow the start-up procedures in this manual.

() If your unit still fails to operate, call your servicing dealer for troubleshooting and repairs. Specify the model and serial numbers of your unit. (Record them in this manual in the space provided.) If the dealer knows exactly which unit you have, he may be able to offer suggestions over the phone, or save valuable time through knowledgeable preparation for the service call.

IN CASE OF TROUBLE

If after performing the above and unit performance is still unsatisfactory, shut off the unit and call your dealer.

Dealer's Name _____

Telephone _____

Unit Model _____

Unit Serial Number _____