

BRINKMANN®

*Grand
Elite Series™*

4905

**ROTISSERIE
OWNER'S MANUAL**

ASSEMBLY AND OPERATING INSTRUCTIONS

**SAVE THIS
MANUAL FOR
FUTURE REFERENCE**

⚠WARNING

**READ AND FOLLOW ALL
WARNINGS AND INSTRUCTIONS IN
THIS MANUAL TO AVOID PERSONAL
INJURY, INCLUDING DEATH OR
PROPERTY DAMAGE.**

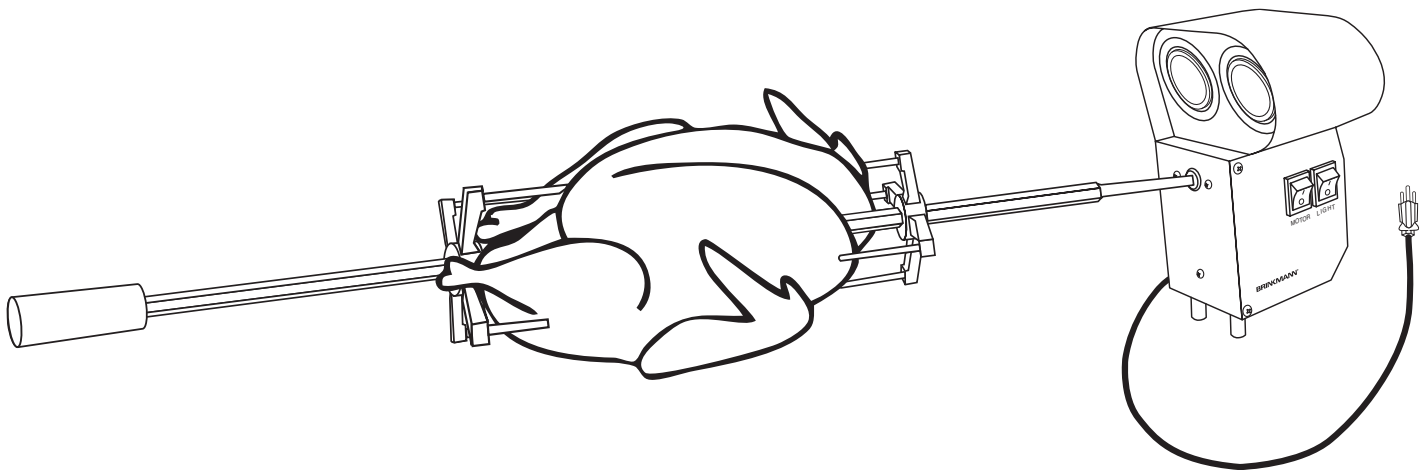



IMPORTANT SAFETY WARNINGS

WE WANT YOU TO ASSEMBLE AND USE YOUR ROTISSERIE AS SAFELY AS POSSIBLE. THE PURPOSE OF THIS SAFETY ALERT SYMBOL  IS TO ATTRACT YOUR ATTENTION TO POSSIBLE HAZARDS AS YOU ASSEMBLE AND USE YOUR ROTISSERIE.

WHEN YOU SEE THE SAFETY ALERT SYMBOL  PAY CLOSE ATTENTION TO THE INFORMATION WHICH FOLLOWS!

 READ ALL SAFETY WARNINGS AND INSTRUCTIONS CAREFULLY BEFORE ASSEMBLING AND OPERATING YOUR ROTISSERIE.

WARNING

ELECTRICAL GROUNDING INSTRUCTIONS:

This appliance (roastisserie motor) is equipped with a three-prong (grounding) plug for your protection against electrical shock hazard. It should be plugged directly into a properly grounded three-prong receptacle. DO NOT cut or remove the grounding prong from this plug.

- Always check the grill prior to each use as indicated in the “Pre-Start Check List” section of the Grand Elite Series™ Owner’s Manual.
- Keep children and pets away. DO NOT allow children to use or play near the grill or roastisserie.
- DO NOT leave the grill unattended while in use.
- DO NOT use the side burner when using a roastisserie. Burner lid could be hot from prior use.
- To avoid body injury, DO NOT touch spit rod while in use or soon after use, rod can be EXTREMELY HOT.
- Keep any electrical supply cords away from water or hot surfaces.
- DO NOT operate with a damaged cord or plug.
- Turn roastisserie motor switch to “OFF” before removing plug from outlet.
- Unplug the roastisserie motor when not in use and before cleaning.
- DO NOT exceed 12 lbs. of food on the roastisserie.
- Keep a fire extinguisher acceptable for use with gas products close by. Refer to your local authority to determine proper size and type.
- For household use only. DO NOT use the grill or this roastisserie for anything other than its intended purpose.
- DO NOT use while under the influence of drugs or alcohol.
- When using an AC current roastisserie, it must be electrically grounded in accordance with local codes, or in the absence of local codes:
 - In the US: The National Electrical Code – ANSI-NFPA No. 70 – Latest Edition
 - In Canada: the Canadian Electrical Code – CSA C22.1

 USE CAUTION AND COMMON SENSE WHEN OPERATING YOUR GAS GRILL. FAILURE TO ADHERE TO THE SAFETY WARNINGS AND GUIDELINES IN THIS MANUAL COULD RESULT IN SEVERE BODILY INJURY OR PROPERTY DAMAGE.

SAVE THIS MANUAL FOR FUTURE REFERENCE.

ASSEMBLY INSTRUCTIONS

⚠ READ ALL SAFETY WARNINGS & ASSEMBLY INSTRUCTIONS CAREFULLY BEFORE ASSEMBLING OR OPERATING YOUR ROTISSERIE.

READ THE OWNERS MANUAL TO THE GRILL BEFORE ASSEMBLING OR USING THIS ROTISSERIE.

No tools are required to assemble this Brinkmann Grand Elite Series™ Rotisserie:

PARTS LIST:

- | | | |
|---|---|-------------|
| ① | 1 | Motor |
| ② | 1 | Spit Rod |
| ③ | 2 | Forks |
| ④ | 2 | Lock Screws |

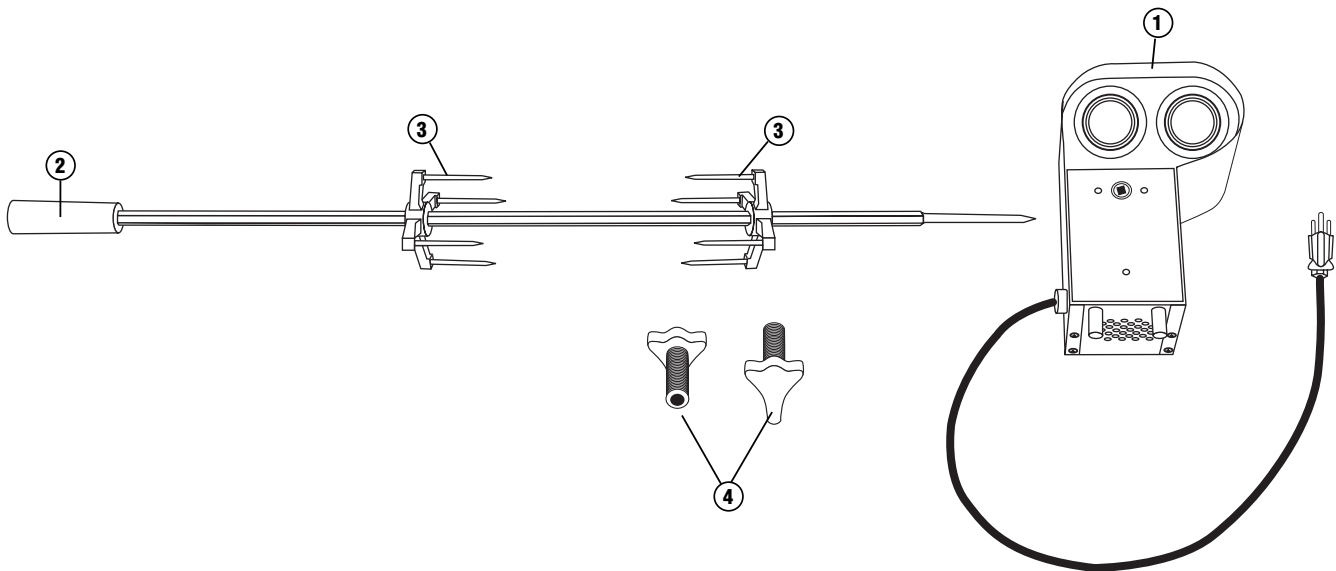

FOR MISSING PARTS, PLEASE CALL CUSTOMER SERVICE AT 800-527-0717.

(Proof of purchase will be required.)

Inspect contents of the box to ensure all parts are included and undamaged.

ASSEMBLY STEPS

Step 1

Open grill hood and remove cooking grills. Refer to your Grand Elite Series owners manual.

Step 2

Install the rotisserie onto the right side grill bracket by inserting post into bracket holes. Lock into position using the two screws provided.

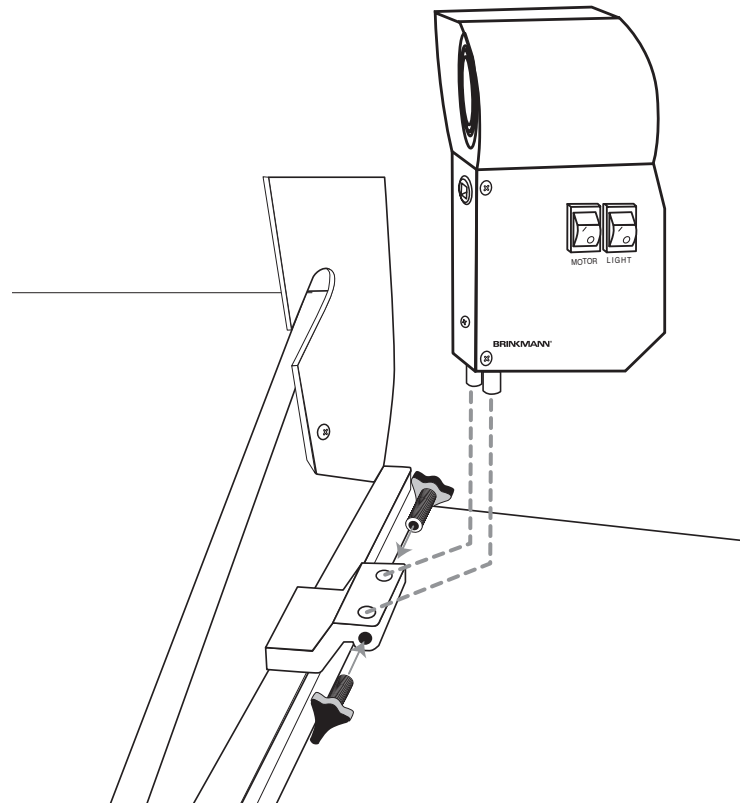

READ ALL WARNINGS ON PAGE 1 AND IN THE OWNERS MANUAL TO THE GRILL.

⚠ WARNING

ELECTRICAL GROUNDING INSTRUCTIONS:

This appliance (rotisserie motor) is equipped with a three-prong (grounding) plug for your protection against electrical shock hazard. It should be plugged directly into a properly grounded three-prong receptacle. **DO NOT** cut or remove the grounding prong from this plug.

OPERATING THE ROTISSERIE:

1. Your grill was pre-drilled from the factory to include mounting holes for the Brinkmann Grand Elite Series™ Rotisserie.
2. Install the rotisserie motor onto the motor mount bracket.
3. Ensure that the rotisserie motor is turned to “OFF.”

Note: Rotisserie motor is capable of turning up to a 12 lb. cut of meat or poultry.

4. Place one fork onto the spit rod with the prongs facing away from the wooden handle. Do not tighten set screw at this time.
5. Skewer meat with the spit rod and slide to the center of the rod.
6. Place second fork onto the spit rod with the prongs facing the meat.
7. Slide both forks tightly against the meat and securely tighten the fork set screws.
8. Check the balance of the food on the rod by rotating the loaded spit rod loosely in your hands. The rod should rotate evenly with little effort. Adjust the food on the spit to achieve a balanced assembly.
9. Place the loaded spit rod into the motor assembly and support bracket.
10. Close the grill lid and turn the rotisserie motor “ON.”

Note: Erratic noises from the motor are a sign of an unbalanced spit rod. Which could cause severe damage to motor gears.

⚠ WARNING: Always use oven mitts/gloves to protect your hands. Metal parts become hot during use. Use extreme caution when handling spit rod and forks.

11. Always turn the rotisserie motor to “OFF” before opening the grill lid.

ROTISSERIE COOKING CONTINUED:

12. When food is done, use oven mitts/gloves to remove spit rod from motor assembly.
13. Loosen fork set screws and remove meat by sliding off the end of the spit rod.

GRILLING TO PROPER TEMPERATURE:

- Use a meat thermometer to be sure food has reached a safe internal temperature. You may order a Commercial-quality thermometer from Brinkmann. For more information on this product and other Brinkmann accessories, please refer to the accessory pages at the end of this manual.
- The US Department of Agriculture recommends the minimum temperature be reached for the following food items:

Pork ----- 160° F

Poultry ----- 180° F

Roasts ----- 145° F

HELPFUL HINTS

- If you pre-cook meat or poultry, do so immediately before grilling.
- Never defrost meat at room temperature or on a countertop.
- Refrigerate leftovers within 2 hours of taking food off the grill.

For additional information, please phone the USDA's toll free Meat & Poultry Hotline at:

800-535-4555

CLEANING AND MAINTENANCE:

- Spit rod and forks can be disassembled and washed in dish soap and warm water.

Note: All metal parts, with exception of the motor, are dishwasher safe.

- After first use, it is likely that the stainless steel adjacent to the burner will darken. This is a normal property of stainless steel used on the rotisserie.
- Store motor and other parts in a cool, clean and dry place.
- To prevent electrical shock hazard, DO NOT immerse the motor or cord in water.

1-YEAR LIMITED WARRANTY

For 1-year from date of purchase, The Brinkmann Corporation warrants the Brinkmann Grand Elite Series™ Rotisserie against defects due to workmanship or materials to the original purchaser. The Brinkmann Corporation's obligations under this warranty are limited to the following guidelines:

- This warranty does not cover rotisserie that have been altered or damaged due to: normal wear, rust, abuse, improper maintenance, improper use, disassembly of parts and/or attempted repair by anyone other than an authorized employee of The Brinkmann Corporation.
- This warranty does not cover surface scratches, rust or heat damage/discoloration to the finish, which is considered normal wear.
- The Brinkmann Corporation may elect to repair or replace damaged units covered by the terms of this warranty.
- This warranty extends to the original purchaser only and is not transferable or assignable to subsequent purchasers.

The Brinkmann Corporation requires reasonable proof of purchase. Therefore, we strongly recommend that you retain your sales receipt or invoice. To obtain replacement parts for your Brinkmann Grand Elite Series™ Rotisserie under the terms of this warranty, please call Customer Service Department at 800-527-0717. **A receipt will be required. The Brinkmann Corporation will not be responsible for any rotisseries forwarded to us without prior authorization.**

EXCEPT AS ABOVE STATED, THE BRINKMANN CORPORATION MAKES NO OTHER EXPRESS WARRANTY.

THE IMPLIED WARRANTIES OF MERCHANTABILITY AND FITNESS FOR A PARTICULAR PURPOSE ARE LIMITED IN DURATION TO 1-YEAR FROM THE DATE OF PURCHASE. SOME STATES DO NOT ALLOW LIMITATIONS ON HOW LONG AN IMPLIED WARRANTY LASTS, SO THE ABOVE LIMITATION MAY NOT APPLY TO YOU.

ANY LIABILITY FOR INDIRECT, INCIDENTAL OR CONSEQUENTIAL DAMAGES ARISING FROM THE FAILURE OF THE BRINKMANN GRAND ELITE SERIES™ ROTISSERIE TO COMPLY WITH THIS WARRANTY OR ANY IMPLIED WARRANTY IS EXCLUDED. CUSTOMER ACKNOWLEDGES THAT THE PURCHASE PRICE CHARGED IS BASED UPON THE LIMITATIONS CONTAINED IN THE WARRANTY SET OUT ABOVE. SOME STATES DO NOT ALLOW THE EXCLUSION OR LIMITATION OF INCIDENTAL OR CONSEQUENTIAL DAMAGES, SO THE ABOVE LIMITATION OR EXCLUSION MAY NOT APPLY TO YOU. THIS WARRANTY GIVES YOU SPECIFIC LEGAL RIGHTS, AND YOU MAY ALSO HAVE OTHER RIGHTS WHICH VARY FROM STATE TO STATE.