

Hoshizaki America, Inc.

Dishwasher

Models

JWE-2400CUA-L-25B

JWE-2400CUA-R-25B



“A Superior Degree
of Reliability”

www.hoshizaki.com

PARTS LIST



Number: J002-3446
Issued: 3 -1 - 2011
Revised: 10-26-2012

Auxiliary Codes

JWE-2400CUA-L-25B

JWE-2400CUA-R-25B

A-1 March 2011

B-0 January 2012

B-1 April 2012

Auxiliary Code Breakdown

The auxiliary code is the first two characters in the serial number. The first character indicates the year. Years progress or regress in alphabetical order. The series runs from "A" through "V" and the letters "I" and "O" are skipped. The second character indicates significant part changes within a year. Base is "0" and this number advances for each change. In cases where there is a letter in parentheses, this designates the month. This is the last character in the serial number. The series runs from "(A)" through "(M)" and the letter "(I)" is skipped. This designation is only included when identifying a parts change within an auxiliary code.

Note About Ordering Parts

Most assemblies cannot be ordered as complete units; parts in the assemblies generally must be ordered separately.

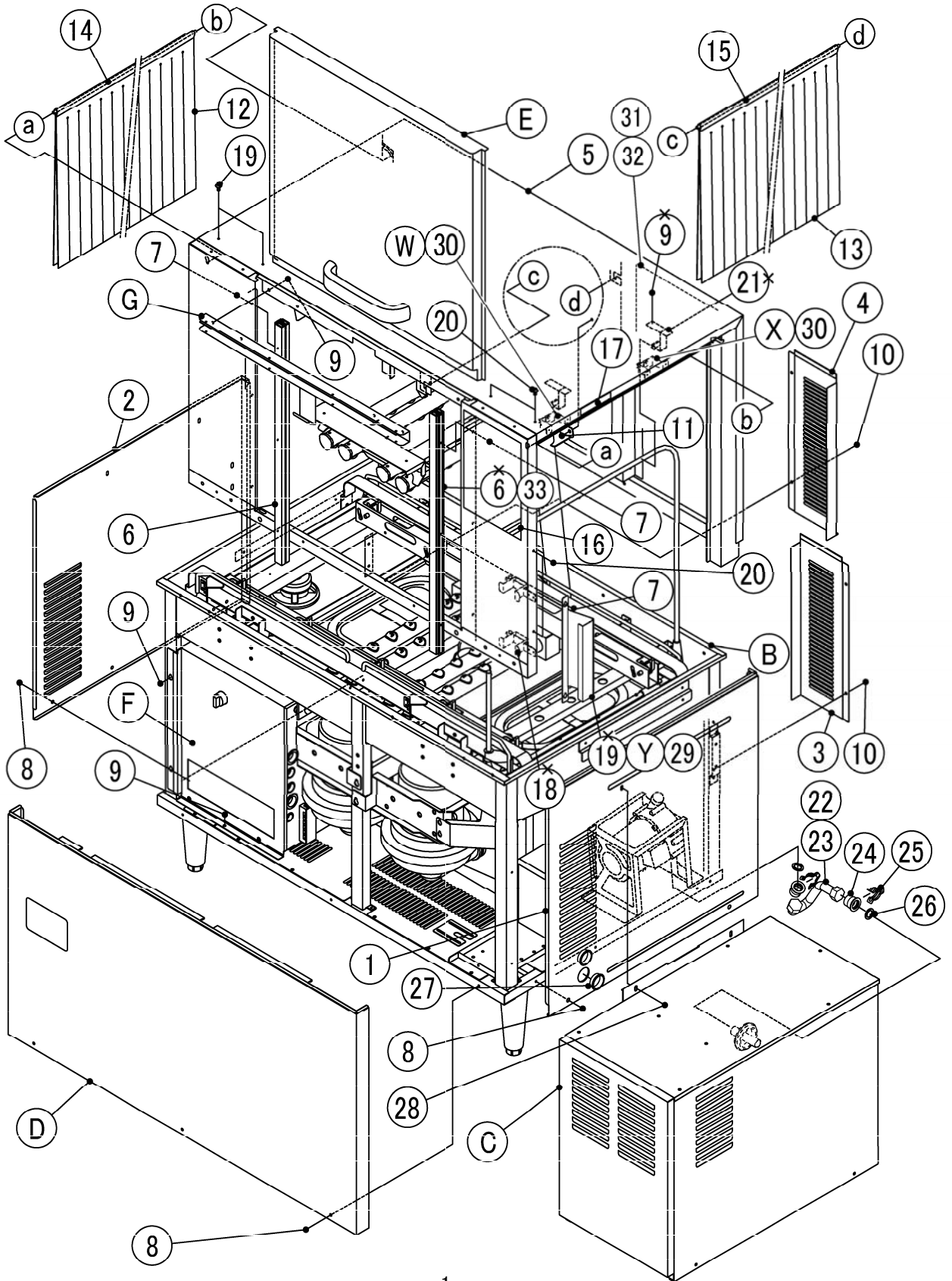

HA

| MODEL : JWE-2400CUA-L-25B | | TITLE : A. DISHWASHER ASSY | | | | | |
|---------------------------|--------------------------|----------------------------|-------------|--------------|-----|--|--|
| INDEX NO. | DESCRIPTION | MATERIAL OR MODEL NUMBER | PART NUMBER | REQ'D NUMBER | | | |
| | | | | A-1 B-0 | B-1 | | |
| B | TANK ASSY | - | 1H4641007 | 1 | 1 | | |
| C | BOOSTER ASSY | - | 1H4673A01 | 1 | 1 | | |
| D | FRONT PANEL ASSY | - | 2H9952A01 | 1 | 1 | | |
| E | SERVICE PANEL ASSY | - | 2H8185A02 | 1 | 1 | | |
| F | CONTROL BOX ASSY | - | 1H4674A01 | 1 | 1 | | |
| G | HOOK ASSY | - | 3Y2348A01 | 1 | 1 | | |
| W | RINSE BRACKET A - ASSY | | 3Y6625A01 | | 1 | | |
| X | RINSE BRACKET B - ASSY | | 3Y6626A01 | | 1 | | |
| Y | RINSE BRACKET C - ASSY | | 3Y6629A01 | | 1 | | |
| Z | ACCESSORIES | - | A02280-01 | 1 | 1 | | |
| 1 | SIDE PANEL (R-L) | S.S | 3Y5367G01 | 1 | 1 | | |
| 2 | SIDE PANEL (L-L) | S.S | 3Y5342A01 | 1 | 1 | | |
| 3 | REAR PANEL (R-L) | S.S | 3Y5052M01 | 1 | 1 | | |
| 4 | REAR PANEL (L-L) | S.S | 3Y5379M01 | 1 | 1 | | |
| 5 | TOP PANEL (L) | S.S | 1H4675G01 | 1 | - | | |
| | | | 1H5149G01 | | 1 | | |
| 6 | RAIL | PVC | 3Y2211P01 | 2 | 1 | | |
| 7 | TRUSS HEAD TAPPING SCREW | S.S | FT20408M0 | 6 | 6 | | |
| 8 | TRUSS HEAD MACHINE SCREW | S.S | P01647-01 | 7 | 7 | | |
| 9 | HEX HEAD BOLT W/ WASHERS | S.S | FBK0408S0 | 13 | 9 | | |
| 10 | FLANGE BOLT | S.S | FTF0408S0 | 4 | 4 | | |
| 11 | HEX HEAD BOLT W/ WASHERS | S.S | FBK0512S0 | 24 | 24 | | |
| 12 | CURTAIN (S) | TPE | 2X0869P01 | 2 | 2 | | |
| 13 | CURTAIN (L) | TPE | 2X0870P01 | 1 | 1 | | |
| 14 | SHAFT-CURTAIN | S.S | 4Y4129M01 | 2 | 2 | | |
| 15 | SHAFT-CURTAIN | S.S | 4Y4129M02 | 1 | 1 | | |
| 16 | MAINTENANCE LABEL | - | 373615L01 | 1 | 1 | | |
| 17 | WARNING LABEL | - | 474626L01 | 2 | 2 | | |
| 18 | SUPPORT-RINSE BRACKET | S.S | 4Y4497M02 | 2 | - | | |
| 19 | GUARD-RINSE (L) | S.S | 3Y5377M01 | 1 | - | | |
| 20 | HEX HEAD BOLT W/ WASHERS | S.S | FBK0412S0 | 2 | 2 | | |
| 21 | BRACKET - RINSE PIPE | S.S | 4Y6884G01 | 2 | - | | |

HA

| MODEL : JWE-2400CUA-L-25B | | TITLE : A. DISHWASHER ASSY | | | | | |
|---------------------------|---|----------------------------|-------------|--------------|-----|--|--|
| INDEX NO. | DESCRIPTION | MATERIAL OR MODEL NUMBER | PART NUMBER | REQ'D NUMBER | | | |
| | | | | A-1 B-0 | B-1 | | |
| 22 | FLEXIBLE PIPE | S.S | 442363-12 | 1 | 1 | | |
| 23 | PACKING | - | 442363F01 | 2 | 2 | | |
| 24 | BUSH - BOOSTER (OUT) | S.S | 4Y6911M01 | 2 | 2 | | |
| 25 | QUICK FASTENER | 16B-R3 | 456912-07 | 2 | 2 | | |
| 26 | U-PACKING | EPDM | 4Y3371-03 | 2 | 2 | | |
| 27 | BUSHING | SB-1500-21 | 420470-06 | 2 | 2 | | |
| 28 | HEX HEAD BOLT W/ WASHERS | S.S | FBK0510S0 | 2 | 2 | | |
| 29 | HEX HEAD BOLT (SPRING WASHER AND FLAT WASHER) | | FBK0408S1 | | 4 | | |
| 30 | SCREW | | 4Y1319-05 | | 4 | | |
| 31 | GUARD - REAR | | 3Y6612M01 | | 1 | | |
| 32 | HEX HEAD BOLT (SPRING WASHER AND FLAT WASHER) | | FBK0510S1 | | 6 | | |
| 33 | RAIL | | 3Y6624P01 | | 1 | | |
| | | | | | | | |
| | | | | | | | |
| | | | | | | | |
| | | | | | | | |
| | | | | | | | |
| | | | | | | | |
| | | | | | | | |
| | | | | | | | |
| | | | | | | | |
| | | | | | | | |
| | | | | | | | |
| | | | | | | | |
| | | | | | | | |
| | | | | | | | |
| | | | | | | | |
| | | | | | | | |
| | | | | | | | |
| | | | | | | | |
| | | | | | | | |
| | | | | | | | |
| | | | | | | | |
| | | | | | | | |
| | | | | | | | |
| | | | | | | | |
| | | | | | | | |
| | | | | | | | |

B. TANK ASSY (1/2)

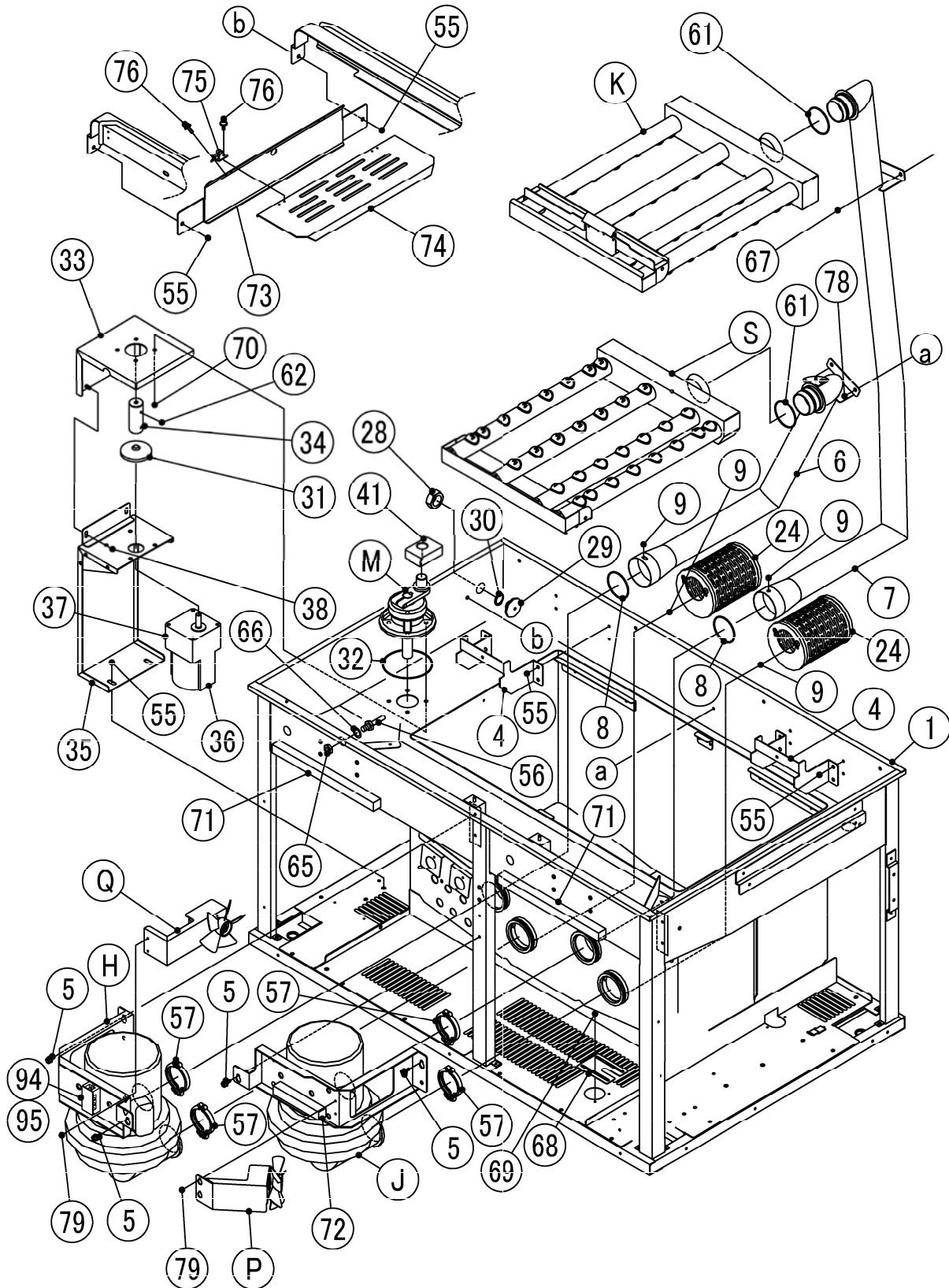

B. TANK ASSY (2/2)

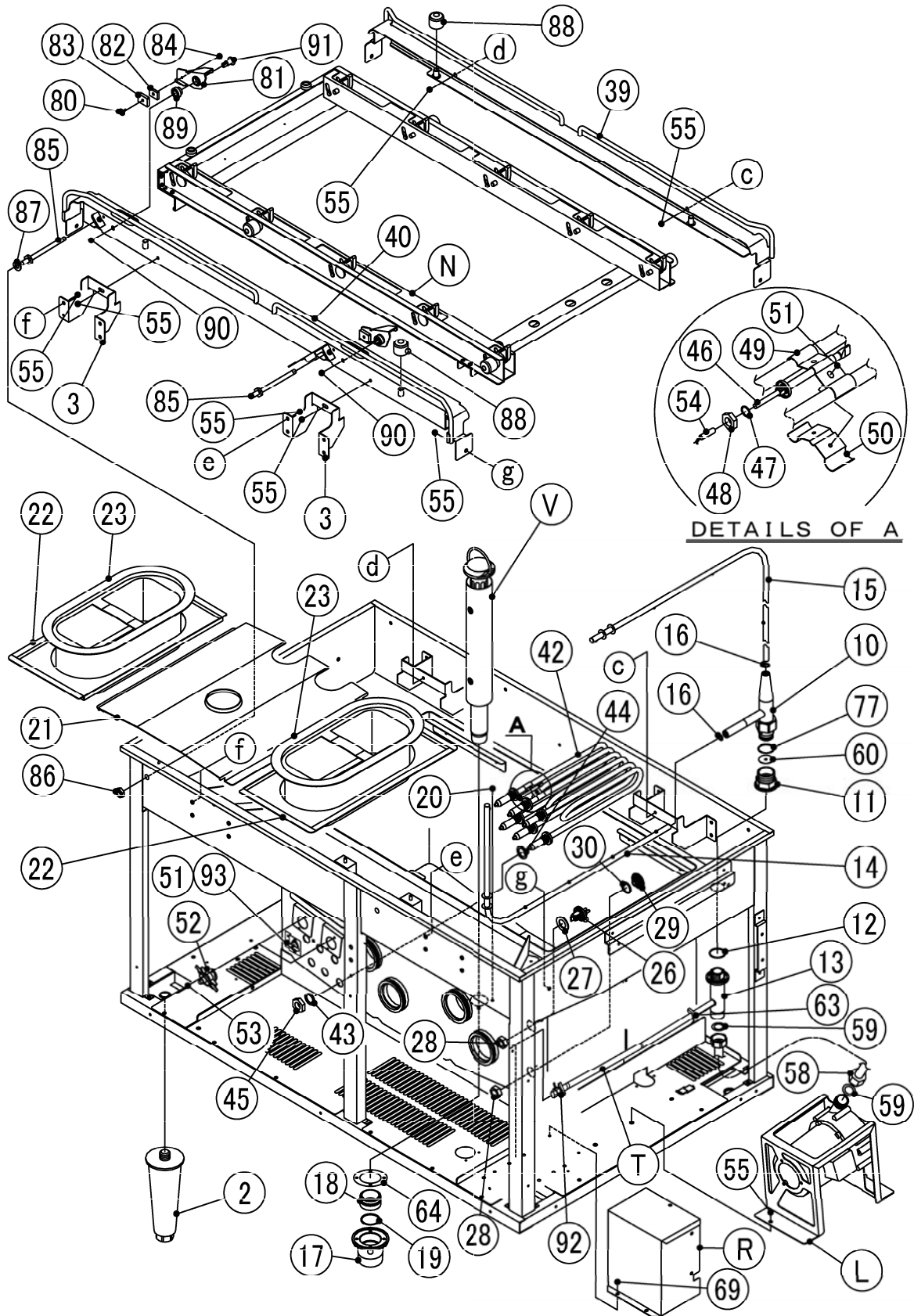

HA

| MODEL : JWE-2400CUA-L-25B TITLE : B. TANK ASSY | | | | | | | |
|--|--------------------------|--------------------------|-------------|--------------|-----|--|--|
| INDEX NO. | DESCRIPTION | MATERIAL OR MODEL NUMBER | PART NUMBER | REQ'D NUMBER | | | |
| | | | | A-1 B-0 | B-1 | | |
| H | WASH PUMP (B) ASSY | - | 3Y2257A02 | 1 | 1 | | |
| J | WASH PUMP (A) ASSY | - | 3Y2256A02 | 1 | 1 | | |
| K | SPRAY ARM (UP) ASSY | - | 3Y2572A02 | 1 | 1 | | |
| L | RINSE PUMP ASSY | - | 3Y5396A01 | 1 | 1 | | |
| M | CRANK UNIT ASSY | - | 2X0331A02 | 1 | 1 | | |
| N | CONVEYOR RAIL ASSY | - | 1H4648A02 | 1 | 1 | | |
| P | FAN MOTOR ASSY | - | 4Y4175A02 | 1 | 1 | | |
| Q | FAN MOTOR (B) ASSY | - | 4Y4242A02 | 1 | 1 | | |
| R | FAN MOTOR (C) ASSY | - | 4Y6603A01 | 1 | 1 | | |
| S | SPRAY ARM (LO) ASSY | - | 3Y2573A02 | 1 | 1 | | |
| T | HOSE - CLEANSER ASSY | - | 4Y4186A02 | 1 | 1 | | |
| V | OVERFLOW PIPE ASSY | | 3Y6607A01 | 1 | 1 | | |
| 1 | FLUSH TANK (L) | S.S | 1H4736G01 | 1 | 1 | | |
| 2 | ADJUSTABLE LEG | SD-240HF-D | P01591-01 | 4 | 4 | | |
| 3 | BRACKET (B) - RAIL | S.S | 4Y6418M02 | 2 | 2 | | |
| 4 | BRACKET (A) - RAIL | S.S | 4Y6417M02 | 2 | 2 | | |
| 5 | HEX HEAD BOLT W/ WASHERS | S.S | FBK0512S1 | 6 | 6 | | |
| 6 | WASH PIPE (LO) | S.S | 2H8701G02 | 1 | 1 | | |
| 7 | WASH PIPE (UP) | S.S | 2H8155G02 | 1 | 1 | | |
| 8 | O-RING | NBR | 7611-G055 | 2 | 2 | | |
| 9 | HEX HEAD BOLT W/ WASHERS | S.S | FBK0408S0 | 6 | 6 | | |
| 10 | CLEAN PIPE (C) | S.S | 3Y2820G01 | 1 | 1 | | |
| 11 | JOINT - CLEAN PIPE | S.S | 4Y4548M01 | 1 | 1 | | |
| 12 | O-RING | NBR | 7611-P028 | 1 | 1 | | |
| 13 | CLEAN PIPE (B) | S.S | 4Y6919G01 | 1 | 1 | | |
| 14 | RINSE PIPE (LO) | S.S | 3Y2223G01 | 1 | - | | |
| | | | 3Y6568G01 | | 1 | | |
| 15 | RINSE PIPE (UP) | S.S | 3Y2225G01 | 1 | - | | |
| | | | 3Y6567G01 | | 1 | | |
| 16 | U-PACKING | EPDM | 4Y3371-04 | 2 | 2 | | |
| 17 | DRAIN PIPE | S.S | 3Y5054M01 | 1 | 1 | | |
| 18 | JOINT - OVERFLOW | PE | 4Y3176-01 | 1 | 1 | | |

HA

| MODEL : JWE-2400CUA-L-25B TITLE : B. TANK ASSY | | | | | | | |
|--|------------------------|--------------------------|-------------|--------------|-----|--|--|
| INDEX NO. | DESCRIPTION | MATERIAL OR MODEL NUMBER | PART NUMBER | REQ'D NUMBER | | | |
| | | | | A-1 B-0 | B-1 | | |
| 19 | O-RING | NBR | 7611-G050 | 1 | 1 | | |
| 20 | SCREW | S.S | 4Y1319-06 | 4 | 4 | | |
| 21 | SEPARATOR (A) | S.S | 2H8101M02 | 1 | 1 | | |
| 22 | SEPARATOR (B) | S.S | 3Y2237M02 | 2 | 2 | | |
| 23 | TANK FILTER | S.S | 3Y0673G02 | 2 | 2 | | |
| 24 | PUMP GUARD | S.S | 4Y3344G01 | 2 | 2 | | |
| 25 | OVERFLOW PIPE | S.S | 3Y5804G01 | - | - | | |
| 26 | LEVEL SENSOR | | 3X4140G01 | 1 | 1 | | |
| 27 | PACKING (B) - SENSOR | SI.R | 4X5112-01 | 1 | 1 | | |
| 28 | NUT | M22 | 4Y3670-01 | 3 | 3 | | |
| 29 | CAP | PPS | 4Y3177-01 | 2 | 2 | | |
| 30 | O-RING | EPDM | 7614-G025 | 2 | 2 | | |
| 31 | FRINGER | NBR | 4Y6567R01 | 1 | 1 | | |
| 32 | O-RING | NBR | 7611-P070 | 1 | 1 | | |
| 33 | BRACKET (A) - GM | S.S | 4Y7052G02 | 1 | 1 | | |
| 34 | COUPLING (B) | S.S | 4Y7051M01 | 1 | 1 | | |
| 35 | BRACKET (J) - GM | S.S | 3Y3094G02 | 1 | 1 | | |
| 36 | GEARMOTOR | M9MX40G4YG | P01695-01 | 1 | 1 | | |
| 37 | GEARHEAD | MX9G60B | P01696-01 | 1 | 1 | | |
| 38 | U-NUT | S.S | FNU106S0 | 2 | 2 | | |
| 39 | RACK RAIL (B-L) | S.S | 3Y4825G02 | 1 | 1 | | |
| 40 | RACK RAIL (A-L) | S.S | 3Y4824G01 | 1 | 1 | | |
| 41 | SLIDE BLOCK | PE | 4Y4138P01 | 1 | 1 | | |
| 42 | SHEATH HEATER | HU23280D | P01721-01 | 6 | 6 | | |
| 43 | WASHER | S.S | P01721F01 | 12 | 12 | | |
| 44 | PACKING | SI.R | P01721F02 | 12 | 12 | | |
| 45 | NUT | S.S | P01721F03 | 12 | 12 | | |
| 46 | THERMISTOR PIPE - WELD | S.S | 4Y3183G01 | 1 | 1 | | |
| 47 | O-RING | EPDM | 7614-P007 | 1 | 1 | | |
| 48 | NUT | S.S | FNH106S0 | 1 | 1 | | |
| 49 | THERMOSTAT PLATE (UP) | S.S | 4Y3164-01 | 4 | 4 | | |
| 50 | THERMOSTAT PLATE (LO) | S.S | 4Y3163-01 | 4 | 4 | | |

HA

| MODEL : JWE-2400CUA-L-25B TITLE : B. TANK ASSY | | | | | | | |
|--|-----------------------------------|--------------------------|-------------|--------------|-----|--|--|
| INDEX NO. | DESCRIPTION | MATERIAL OR MODEL NUMBER | PART NUMBER | REQ'D NUMBER | | | |
| | | | | A-1 B-0 | B-1 | | |
| 51 | PAN HEAD MACHINE SCREW W/ WASHERS | S.S | FSK0305S0 | 10 | 10 | | |
| 52 | THERMOSTAT | CR-1 | 4Y1929-02 | 4 | 4 | | |
| 53 | PAN HEAD MACHINE SCREW W/ WASHERS | S.S | FSK0408S0 | 8 | 8 | | |
| 54 | THERMISTOR (A) - ASSY | NTFC-51F-H20-2 | 449758-02 | 1 | 1 | | |
| 55 | HEX HEAD BOLT W/ WASHERS | S.S | FBK0612S1 | 27 | 27 | | |
| 56 | REED SWITCH | HC10 | P00205-01 | 1 | 1 | | |
| 57 | BAND - PUMP | S.S | 4Y7714A02 | 4 | 4 | | |
| 58 | FLEXIBLE PIPE | S.S | 442363-13 | 1 | 1 | | |
| 59 | PACKING - TUBE | | 4H9792-01 | 3 | 3 | | |
| 60 | SPACER (B) - RINSE PUMP | S.S | 4Y4549M02 | 1 | 1 | | |
| 61 | O-RING | NBR | 7611-P045 | 2 | 2 | | |
| 62 | HEX SOCKET SET SCREW (FLAT PO | S.S | FSC0505S0 | 4 | 4 | | |
| 63 | HOSE CLAMP | SNP-7 | 435947-01 | 1 | 1 | | |
| 64 | PACKING - JOINT | EPDM | 4Y3165-01 | 1 | 1 | | |
| 65 | NUT | S.S | P00205F01 | 1 | 1 | | |
| 66 | PACKING | SI.R | P00205F02 | 1 | 1 | | |
| 67 | HEX HEAD BOLT W/ WASHERS | S.S | FBK0512S0 | 2 | 2 | | |
| 68 | SLIDE COVER | S.S | 447336-01 | 1 | 1 | | |
| 69 | FLANGE BOLT | S.S | FBF0408S0 | 5 | 5 | | |
| 70 | HEX HEAD BOLT W/ WASHERS | S.S | FBK0512S1 | 4 | 4 | | |
| 71 | CUSHION (A) | PE | 4Y4369P01 | 2 | 2 | | |
| 72 | CUSHION (B) | PE | 4Y4370P01 | 1 | 1 | | |
| 73 | COVER (A) - FRAME | S.S | 3Y2618M02 | 1 | 1 | | |
| 74 | COVER (B) - FRAME | S.S | 3Y2619M02 | 1 | 1 | | |
| 75 | HINGE | S.S | 443721-01 | 2 | 2 | | |
| 76 | SCREW | S.S | 4Y4752M01 | 8 | 8 | | |
| 77 | O-RING | NBR | 7611AP022 | 1 | 1 | | |
| 78 | HEX HEAD BOLT W/ WASHERS | S.S | FBK0512S0 | 2 | 2 | | |
| 79 | HEX HEAD BOLT W/ WASHERS | S.S | FBK0412S1 | 4 | 4 | | |
| 80 | SCREW | S.S | 4Y1319-06 | 2 | 2 | | |
| 81 | SWITCH PLATE (L) | S.S | 4Y6424G01 | 2 | 2 | | |
| 82 | MAGNET | | P00206-01 | 2 | 2 | | |

HA

| MODEL : JWE-2400CUA-L-25B | | | | | | | | TITLE : B. TANK ASSY | | | | | | | |
|---------------------------|--------------------------|--------------------------|-------------|--------------|-----|--|--|----------------------|--|--|--|--|--|--|--|
| INDEX NO. | DESCRIPTION | MATERIAL OR MODEL NUMBER | PART NUMBER | REQ'D NUMBER | | | | | | | | | | | |
| | | | | A-1 B-0 | B-1 | | | | | | | | | | |
| 83 | MAGNET BRACKET (C) | S.S | 4Y6427M01 | 2 | 2 | | | | | | | | | | |
| 84 | U-NUT | S.S | FNU104S0 | 2 | 2 | | | | | | | | | | |
| 85 | REED SWITCH | HC20 | P01709-01 | 2 | 2 | | | | | | | | | | |
| 86 | NUT | S.S | P01709F01 | 2 | 2 | | | | | | | | | | |
| 87 | PACKING | SI.R | P01709F02 | 2 | 2 | | | | | | | | | | |
| 88 | ROLLER - CONVEYOR RAIL | PE | 4Y4137P01 | 4 | 4 | | | | | | | | | | |
| 89 | SLEEVE (A) - HOOK | PE | 4Y4136P01 | 2 | 2 | | | | | | | | | | |
| 90 | CAPPED U NUT | S.S | FNC108S0 | 2 | 2 | | | | | | | | | | |
| 91 | SHAFT - SWITCH PLATE | S.S | 4Y6428M01 | 2 | 2 | | | | | | | | | | |
| 92 | CLAMP | 4253 | 427902-05 | 1 | 1 | | | | | | | | | | |
| 93 | THERMOSTAT | 05N-V035-090 | P02207-01 | 1 | 1 | | | | | | | | | | |
| 94 | TERMINAL BLOCK | T3052-1-3P-CL1S | P01375-01 | 1 | 1 | | | | | | | | | | |
| 95 | TRUSS HEAD MACHINE SCREW | S.S | FST0410S0 | 2 | 2 | | | | | | | | | | |
| | | | | | | | | | | | | | | | |
| | | | | | | | | | | | | | | | |
| | | | | | | | | | | | | | | | |
| | | | | | | | | | | | | | | | |
| | | | | | | | | | | | | | | | |
| | | | | | | | | | | | | | | | |
| | | | | | | | | | | | | | | | |
| | | | | | | | | | | | | | | | |
| | | | | | | | | | | | | | | | |
| | | | | | | | | | | | | | | | |
| | | | | | | | | | | | | | | | |
| | | | | | | | | | | | | | | | |
| | | | | | | | | | | | | | | | |
| | | | | | | | | | | | | | | | |
| | | | | | | | | | | | | | | | |
| | | | | | | | | | | | | | | | |
| | | | | | | | | | | | | | | | |
| | | | | | | | | | | | | | | | |
| | | | | | | | | | | | | | | | |

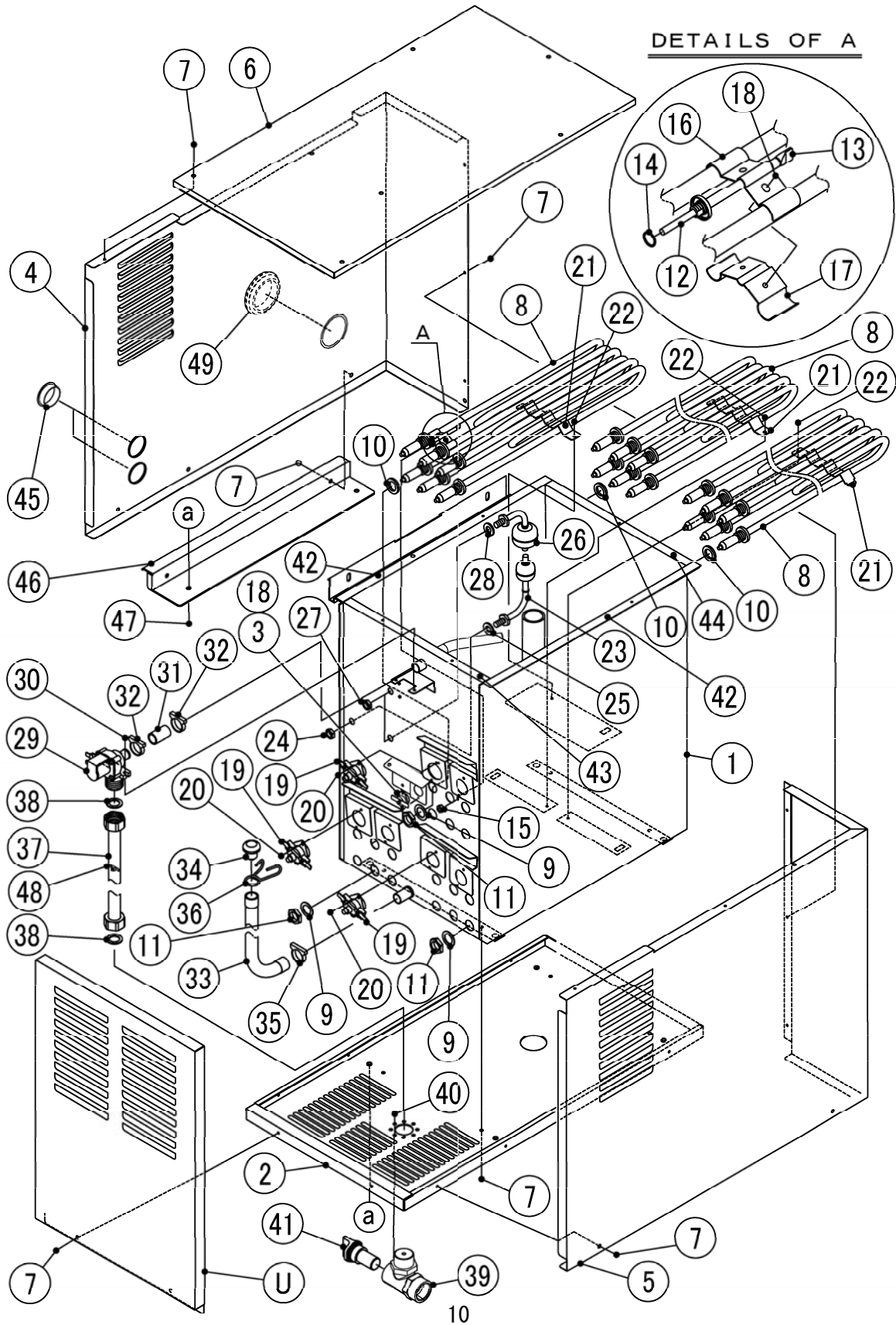

HA

| MODEL : JWE-2400CUA-L-25B TITLE : C. BOOSTER ASSY | | | | | | | |
|---|--------------------------------------|--------------------------|-------------|--------------|-----|--|--|
| INDEX NO. | DESCRIPTION | MATERIAL OR MODEL NUMBER | PART NUMBER | REQ'D NUMBER | | | |
| | | | | A-1 B-0 | B-1 | | |
| U | FRONT PANEL - BOOSTER | - | 3Y5363A01 | 1 | 1 | | |
| 1 | BOOSTER TANK | S.S | 3Y5055G01 | 1 | 1 | | |
| 2 | BASE - BOOSTER | S.S | 3Y5056M01 | 1 | 1 | | |
| 3 | THERMOSTAT | 05N-V035-090 | P02207-01 | 1 | 1 | | |
| 4 | SIDE PANEL (R) - BOOSTER | S.S | 2H9955M01 | 1 | 1 | | |
| 5 | SIDE PANEL (L) - BOOSTER | S.S | 2H9956M01 | 1 | 1 | | |
| 6 | TOP PANEL - BOOSTER | S.S | 3Y5057M01 | 1 | 1 | | |
| 7 | TRUSS HEAD MACHINE SCREW | S.S | FST0408S0 | 19 | 19 | | |
| 8 | SHEATH HEATER | HV-23280D | P01721-01 | 9 | 9 | | |
| 9 | WASHER | S.S | P01721F01 | 18 | 18 | | |
| 10 | PACKING | SI.R | P01721F02 | 18 | 18 | | |
| 11 | NUT | S.S | P01721F03 | 18 | 18 | | |
| 12 | THERMISTOR (C) - ASSY | NTFC-51F-H5-2 | P00574-01 | 1 | 1 | | |
| 13 | THERMISTOR PIPE - WELD | S.S | 4Y3183G01 | 1 | 1 | | |
| 14 | O-RING | EPDM | 7614-P007 | 1 | 1 | | |
| 15 | NUT | S.S | FNH106S0 | 1 | 1 | | |
| 16 | THERMOSTAT PLATE (UP) | S.S | 4Y3164-01 | 1 | 1 | | |
| 17 | THERMOSTAT PLATE (LO) | S.S | 4Y3163-01 | 1 | 1 | | |
| 18 | PAN HEAD MACHINE SCREW W/ WASHERS | S.S | FSK0305S0 | 4 | 4 | | |
| 19 | THERMOSTAT | CR-1 | 4Y1929-02 | 6 | 6 | | |
| 20 | PAN HEAD MACHINE SCREW W/ WASHERS | S.S | FSK0408S0 | 12 | 12 | | |
| 21 | BAND - HEATER | S.S | 4Y6604M01 | 3 | 3 | | |
| 22 | HEX HEAD BOLT W/ WASHERS | S.S | FBK0408S1 | 3 | 3 | | |
| 23 | FLOAT SWITCH | OLV-20-E | 449401-01 | 1 | 1 | | |
| 24 | NUT | S.S | 449401F01 | 1 | 1 | | |
| 25 | PACKING | SI.R | 449401F02 | 1 | 1 | | |
| 26 | FLOAT SWITCH | OLV-20-C1 | 4Y2820-01 | 2 | 2 | | |
| 27 | NUT | S.S | 4Y2820F01 | 2 | 2 | | |
| 28 | PACKING | SI.R | 4Y2820F02 | 2 | 2 | | |
| 29 | WATER VALVE | J248-076F | 456461-01 | 1 | 1 | | |
| 30 | TRUSS HEAD MACHINE SCREW | S.S | FST0410S0 | 2 | 2 | | |
| 31 | HOSE - WV | | 4Y3492-01 | 1 | 1 | | |

HA

| MODEL : JWE-2400CUA-L-25B TITLE : C. BOOSTER ASSY | | | | | | | |
|---|--------------------------|--------------------------|-------------|--------------|-----|--|--|
| INDEX NO. | DESCRIPTION | MATERIAL OR MODEL NUMBER | PART NUMBER | REQ'D NUMBER | | | |
| | | | | A-1 B-0 | B-1 | | |
| 32 | HOSE CLAMP | SNP-14-HSO | P00728-01 | 2 | 2 | | |
| 33 | HOSE (B) - RESERVOIR | EPDM | 4X4283-01 | 1 | 1 | | |
| 34 | CAP (A) | EPDM | 4X3337-01 | 1 | 1 | | |
| 35 | HOSE CLAMP | SNP-16-HSO | P00728-02 | 1 | 1 | | |
| 36 | HOSE BAND | S.S | 427443-06 | 1 | 1 | | |
| 37 | PIPE - WV | S.S | 3Y5058G01 | 1 | 1 | | |
| 38 | PACKING - TUBE | | 4H9792-01 | 2 | 2 | | |
| 39 | STRAINER | S.S | 3Y3522M01 | 1 | 1 | | |
| 40 | FLANGE BOLT (C-TITE) | S.S | FTR0408M0 | 2 | 2 | | |
| 41 | FILTER | | 442086F01 | 1 | 1 | | |
| 42 | PACKING (A) | SI.R | 4Y6605R01 | 2 | 2 | | |
| 43 | PACKING (B) | SI.R | 4Y6606R01 | 1 | 1 | | |
| 44 | PACKING (C) | SI.R | 4Y6607R01 | 1 | 1 | | |
| 45 | BUSHING | SB-1500-21 | 420470-06 | 2 | 2 | | |
| 46 | BRACKET (B) - BOOSTER | S.S | 3Y5059M01 | 1 | 1 | | |
| 47 | HEX HEAD BOLT W/ WASHERS | S.S | FBK0612S0 | 2 | 2 | | |
| 48 | CABLE TIE | CV-150A | 7920-0021 | 1 | 1 | | |
| 49 | GROMMET | EPDM | 410666-17 | 1 | 1 | | |
| | | | | | | | |
| | | | | | | | |
| | | | | | | | |
| | | | | | | | |
| | | | | | | | |
| | | | | | | | |
| | | | | | | | |
| | | | | | | | |
| | | | | | | | |
| | | | | | | | |
| | | | | | | | |
| | | | | | | | |
| | | | | | | | |
| | | | | | | | |
| | | | | | | | |
| | | | | | | | |
| | | | | | | | |

D. FRONT PANEL ASSY

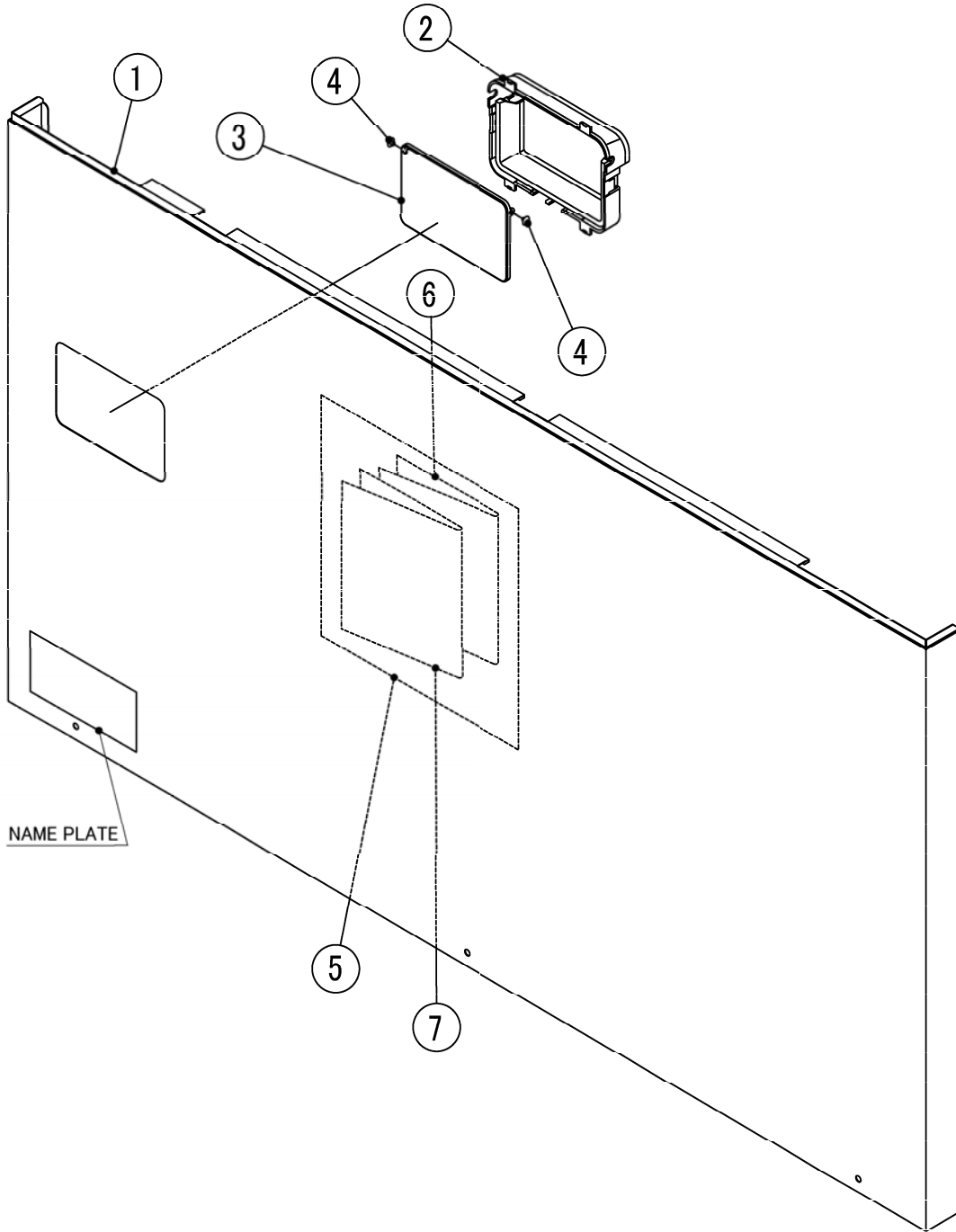

HA

| MODEL : JWE-2400CUA-L-25B TITLE : D. FRONT PANEL ASSY | | | | | | | |
|---|--------------------|--------------------------|-------------|--------------|-----|--|--|
| INDEX NO. | DESCRIPTION | MATERIAL OR MODEL NUMBER | PART NUMBER | REQ'D NUMBER | | | |
| | | | | A-1 B-0 | B-1 | | |
| 1 | FRONT PANEL | S.S | 1H4677M01 | 1 | 1 | | |
| 2 | GUIDE FRAME | ABS | 114731-02 | 1 | 1 | | |
| 3 | COVER - GFCI | S.S | 3Y0753-01 | 1 | 1 | | |
| 4 | PUSH RIVET | PA | 411399-07 | 2 | 2 | | |
| 5 | VINYL CASE | PE | 4X0420-01 | 1 | 1 | | |
| 6 | WIRING LABEL | | 2H9957L01 | 1 | 1 | | |
| 7 | LABEL - CONTROLLER | | 253215L01 | 1 | 1 | | |
| | | | | | | | |
| | | | | | | | |
| | | | | | | | |
| | | | | | | | |
| | | | | | | | |
| | | | | | | | |
| | | | | | | | |
| | | | | | | | |
| | | | | | | | |
| | | | | | | | |
| | | | | | | | |
| | | | | | | | |
| | | | | | | | |
| | | | | | | | |
| | | | | | | | |
| | | | | | | | |
| | | | | | | | |
| | | | | | | | |
| | | | | | | | |
| | | | | | | | |
| | | | | | | | |
| | | | | | | | |
| | | | | | | | |
| | | | | | | | |
| | | | | | | | |
| | | | | | | | |
| | | | | | | | |
| | | | | | | | |
| | | | | | | | |
| | | | | | | | |
| | | | | | | | |
| | | | | | | | |
| | | | | | | | |
| | | | | | | | |
| | | | | | | | |
| | | | | | | | |
| | | | | | | | |
| | | | | | | | |
| | | | | | | | |

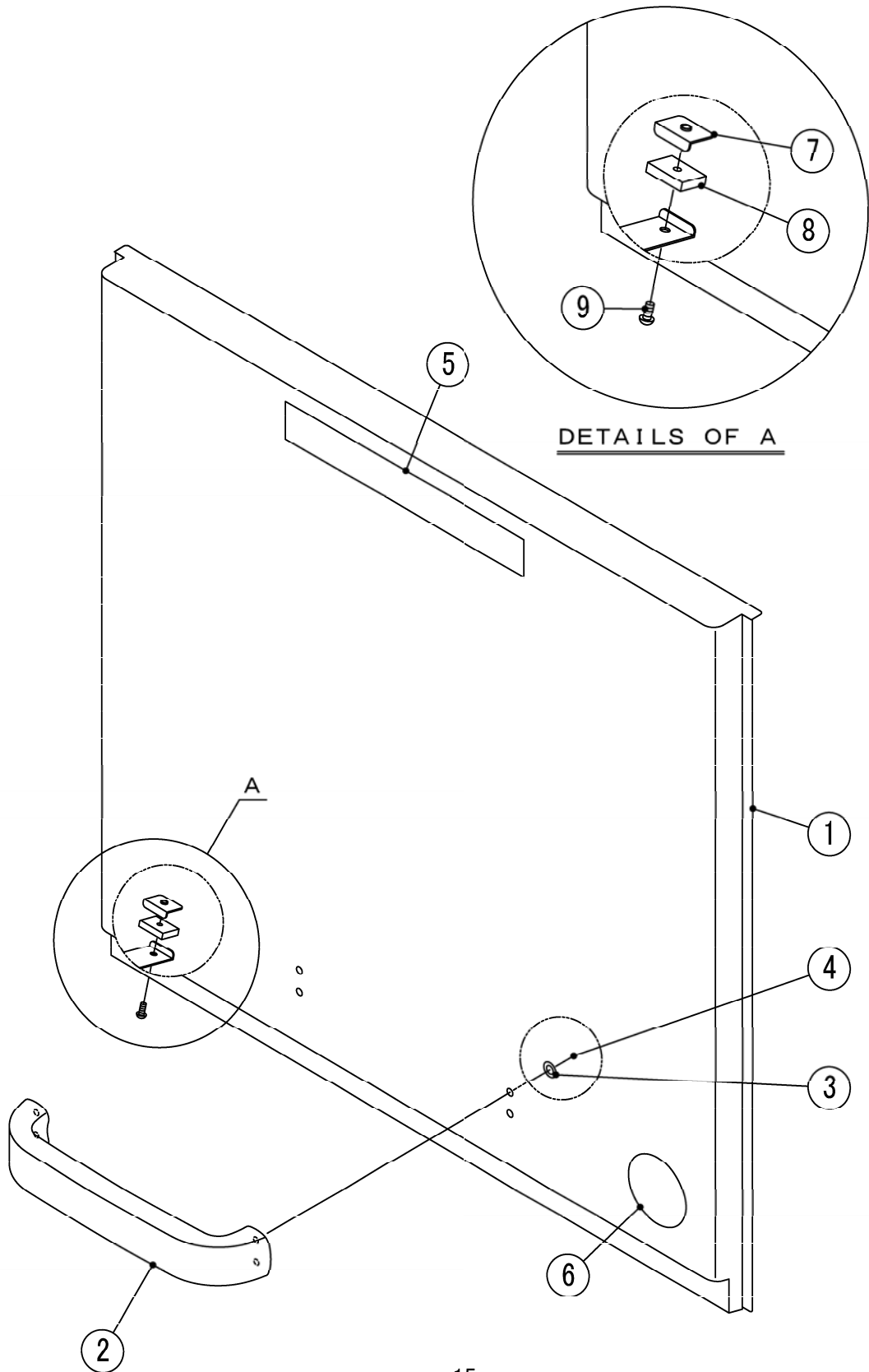

HA

| MODEL : JWE-2400CUA-L-25B | | | | TITLE : E. SERVICE PANEL ASSY | | | |
|---------------------------|--------------------------|--------------------------------|----------------|-------------------------------|-----|--|--|
| INDEX NO. | DESCRIPTION | MATERIAL OR MODEL NUMBER | PART NUMBER | REQ'D NUMBER | | | |
| | | | | A-1 B-0 | B-1 | | |
| 1 | SERVICE PANEL | S.S | 2H8363G02 | 1 | 1 | | |
| 2 | HANDLE | PA | 2H2403G01 | 1 | 1 | | |
| 3 | SEAL WASHER | | 437306-01 | 4 | 4 | | |
| 4 | HEX HEAD BOLT W/ WASHERS | S.S | FBK0516S0 | 4 | 4 | | |
| 5 | EMBLEM | | 340842-01 | 1 | 1 | | |
| 6 | LABEL - PENGUIN | | 453783-01 | 1 | 1 | | |
| 7 | MAGNET BRACKET (B) | S.S | 4Y4222M01 | 1 | 1 | | |
| 8 | MAGNET | | P00206-01 | 1 | 1 | | |
| 9 | SCREW | S.S | 4Y1319-06 | 1 | 1 | | |
| | | | | | | | |
| | | | | | | | |
| | | | | | | | |
| | | | | | | | |
| | | | | | | | |
| | | | | | | | |
| | | | | | | | |
| | | | | | | | |
| | | | | | | | |
| | | | | | | | |
| | | | | | | | |
| | | | | | | | |
| | | | | | | | |
| | | | | | | | |
| | | | | | | | |
| | | | | | | | |
| | | | | | | | |
| | | | | | | | |
| | | | | | | | |
| | | | | | | | |

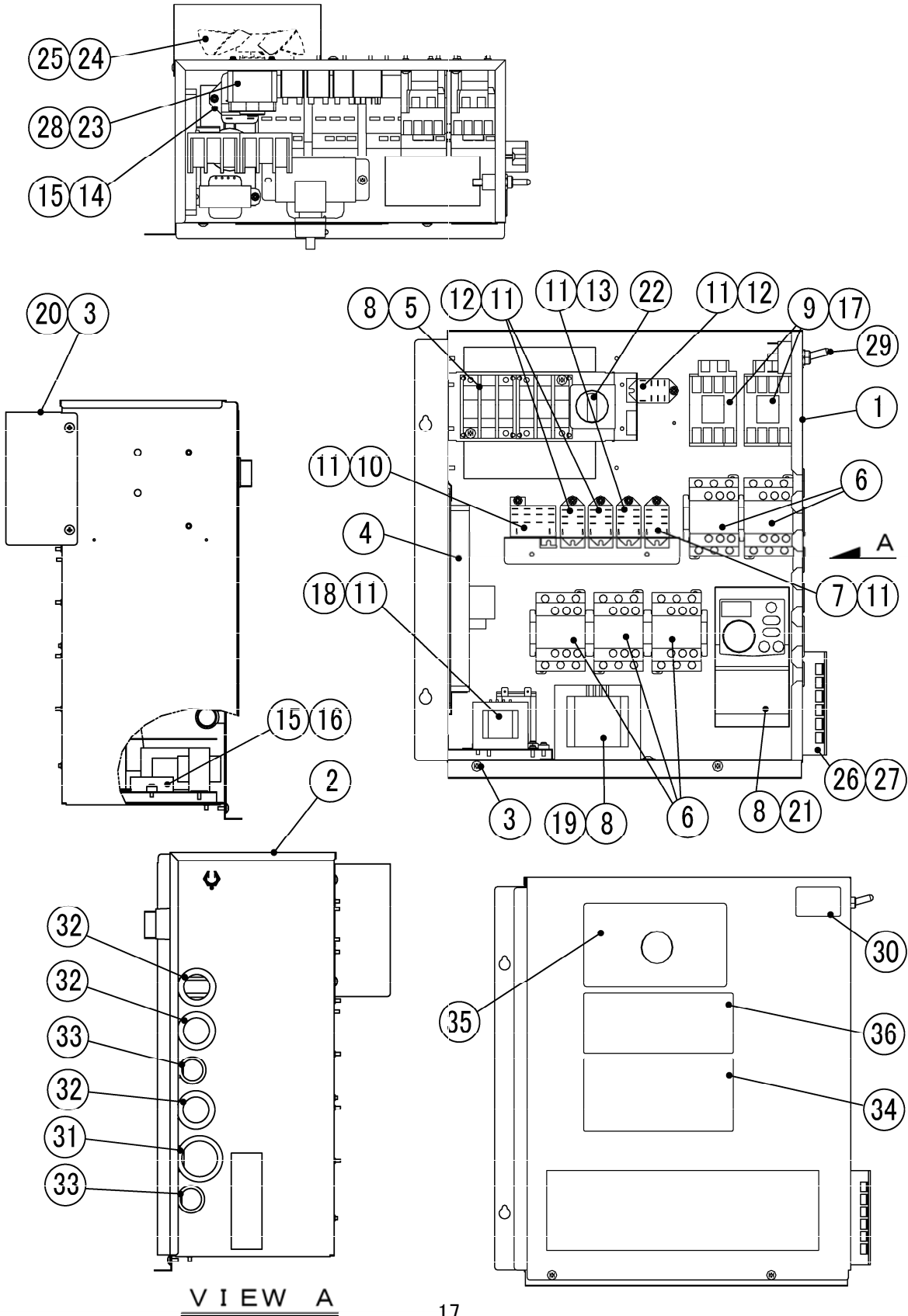

HA

| MODEL : JWE-2400CUA-L-25B | | | | | | | | TITLE : F. CONTROL BOX ASSY | | | | | | | |
|---------------------------|--------------------------------------|--------------------------|-------------|--------------|-----|--|--|-----------------------------|--|--|--|--|--|--|--|
| INDEX NO. | DESCRIPTION | MATERIAL OR MODEL NUMBER | PART NUMBER | REQ'D NUMBER | | | | | | | | | | | |
| | | | | A-1 B-0 | B-1 | | | | | | | | | | |
| 1 | CONTROL BOX | S.S | 2H9958G01 | 1 | 1 | | | | | | | | | | |
| 2 | COVER - CONTROL BOX | S.S | 3Y5060G01 | 1 | 1 | | | | | | | | | | |
| 3 | TRUSS HEAD TAPPING SCREW | S.S | FT20408M0 | 6 | 6 | | | | | | | | | | |
| 4 | CONTROLLER BOARD | HSTZZD0095 | P01831-01 | 1 | 1 | | | | | | | | | | |
| 5 | TERMINAL BLOCK | 1413400 | 4A5358-01 | 2 | 2 | | | | | | | | | | |
| 6 | MAGNETIC CONTACTOR | LC1D186L7-HS | 4Y2392-02 | 5 | 5 | | | | | | | | | | |
| 7 | RELAY | LY2ZF | 406132-05 | 1 | 1 | | | | | | | | | | |
| 8 | TRUSS HEAD MACHINE SCREW | S.S | FST0408S0 | 6 | 6 | | | | | | | | | | |
| 9 | MAGNETIC CONTACTOR | S-N11 | 4Y3365-01 | 2 | 2 | | | | | | | | | | |
| 10 | RELAY | LY4F | 406133-02 | 1 | 1 | | | | | | | | | | |
| 11 | TP TAPPING SCREW | S.S | 431415-01 | 7 | 7 | | | | | | | | | | |
| 12 | RELAY | LY1F | 418271-02 | 3 | 3 | | | | | | | | | | |
| 13 | RELAY | LY2F | 406132-02 | 1 | 1 | | | | | | | | | | |
| 14 | RELAY - PHASE REVERSAL | RDR-S230-M | P01000-01 | 1 | 1 | | | | | | | | | | |
| 15 | TP TAPPING SCREW | S.S | 431415-03 | 4 | 4 | | | | | | | | | | |
| 16 | BUZZER | PKB5-3A24-ASSY | 463024-01 | 1 | 1 | | | | | | | | | | |
| 17 | TRUSS HEAD MACHINE SCREW | S.S | FST0416S0 | 4 | 4 | | | | | | | | | | |
| 18 | TRANSFORMER | 10012 | P01763-01 | 1 | 1 | | | | | | | | | | |
| 19 | TRANSFORMER | HO4118-000 | P02049-01 | 1 | 1 | | | | | | | | | | |
| 20 | COVER (C) -FAN MOTOR | S.S | 4Y4264M01 | 1 | 1 | | | | | | | | | | |
| 21 | INVERTER | FR-D720-0.1K-60 | P01775-01 | 1 | 1 | | | | | | | | | | |
| 22 | SELECT SWITCH | A22-3M | P00202-01 | 1 | 1 | | | | | | | | | | |
| 23 | FAN MOTOR | F3042R | P01203-01 | 1 | 1 | | | | | | | | | | |
| 24 | FAN | PP | 449942-01 | 1 | 1 | | | | | | | | | | |
| 25 | SPEED NUT | S.S | 449942F01 | 1 | 1 | | | | | | | | | | |
| 26 | TERMINAL BLOCK | T3052-1-6P-CS | P01375-04 | 1 | 1 | | | | | | | | | | |
| 27 | TRUSS HEAD MACHINE SCREW | S.S | FST0412S0 | 2 | 2 | | | | | | | | | | |
| 28 | PAN HEAD MACHINE SCREW W/ WASHERS | S.S | FSK0308S0 | 2 | 2 | | | | | | | | | | |
| 29 | VOLTAGE TAP SWITCH | WD11019F | P01446-01 | 1 | 1 | | | | | | | | | | |
| 30 | LABEL-VOLTAGE TAP | | 474063L01 | 1 | 1 | | | | | | | | | | |
| 31 | BUSHING | SB-1375-16 | 420470-04 | 2 | 2 | | | | | | | | | | |
| 32 | BUSHING | OCB-1000 | 428394-05 | 3 | 3 | | | | | | | | | | |

G. HOOK ASSY

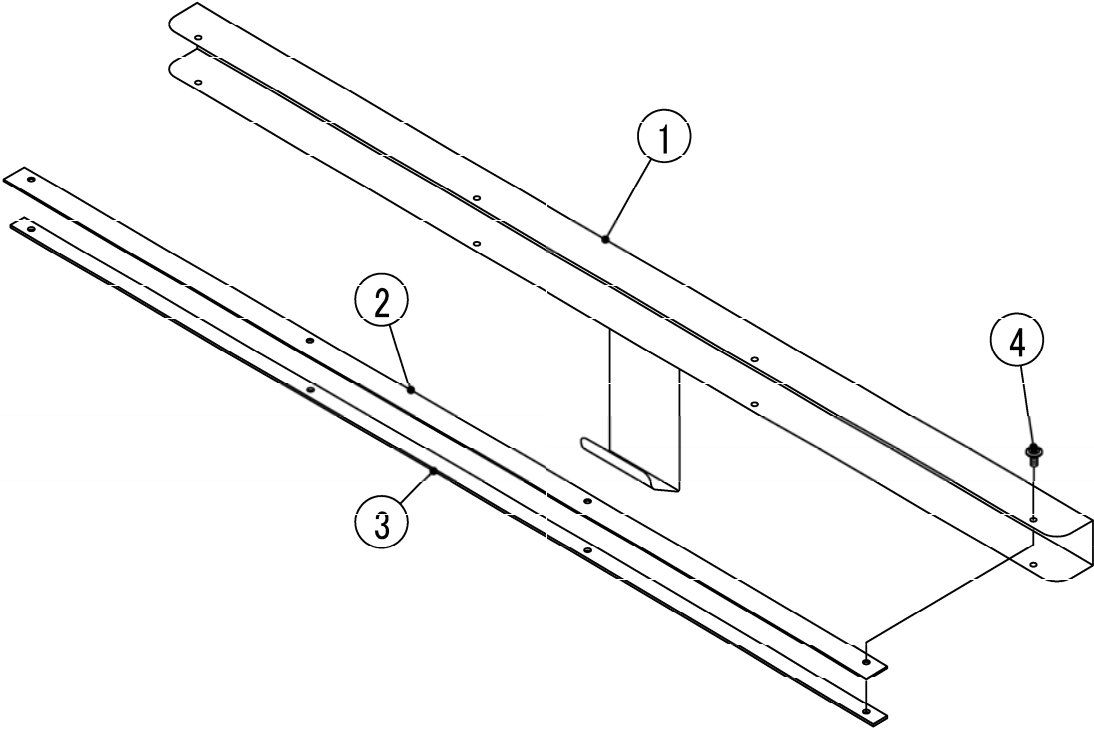

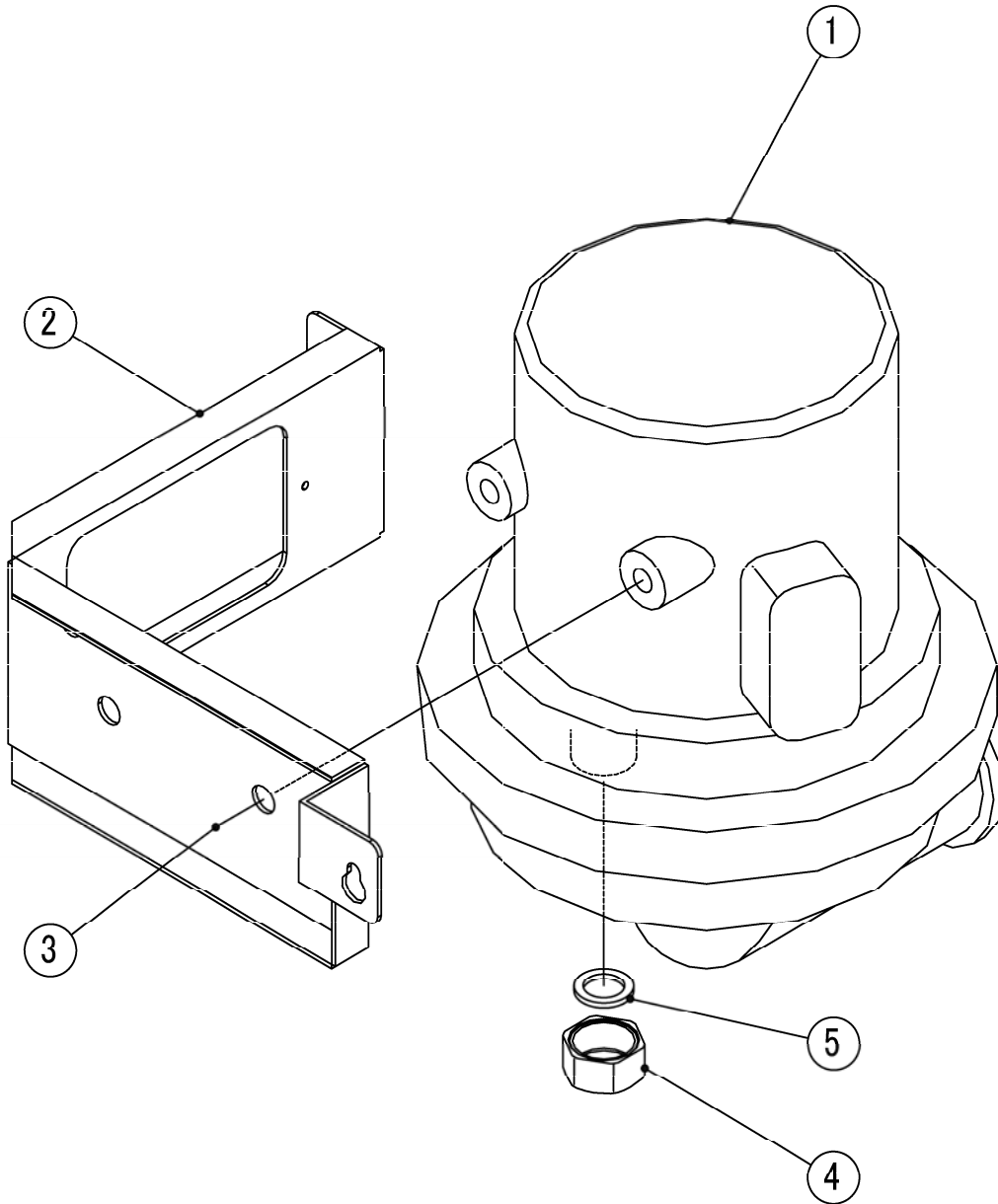

HA

| MODEL : JWE-2400CUA-L-25B | | TITLE : H. WASH PUMP (B) ASSY | | | | | |
|----------------------------------|-------------------------------|--------------------------------------|-------------|--------------|-----|--|--|
| INDEX NO. | DESCRIPTION | MATERIAL OR MODEL NUMBER | PART NUMBER | REQ'D NUMBER | | | |
| | | | | A-1 B-0 | B-1 | | |
| 1 | PUMP MOTOR | 50LPS-3756HUL | P01548-01 | 1 | 1 | | |
| 2 | SUPPORT (B) / WASH PUMP MOTOR | S.S | 3Y2247M02 | 1 | 1 | | |
| 3 | HEX HEAD BOLT W/ WASHERS | S.S | FBK1016S0 | 2 | 2 | | |
| 4 | NUT / WASH PUMP MOTOR | S.S | 4Y4183M01 | 1 | 1 | | |
| 5 | PACKING - TUBE | | 4H9792-01 | 1 | 1 | | |
| | | | | | | | |
| | | | | | | | |
| | | | | | | | |
| | | | | | | | |
| | | | | | | | |
| | | | | | | | |
| | | | | | | | |
| | | | | | | | |
| | | | | | | | |
| | | | | | | | |
| | | | | | | | |
| | | | | | | | |
| | | | | | | | |
| | | | | | | | |
| | | | | | | | |
| | | | | | | | |
| | | | | | | | |
| | | | | | | | |
| | | | | | | | |
| | | | | | | | |
| | | | | | | | |
| | | | | | | | |
| | | | | | | | |
| | | | | | | | |
| | | | | | | | |
| | | | | | | | |

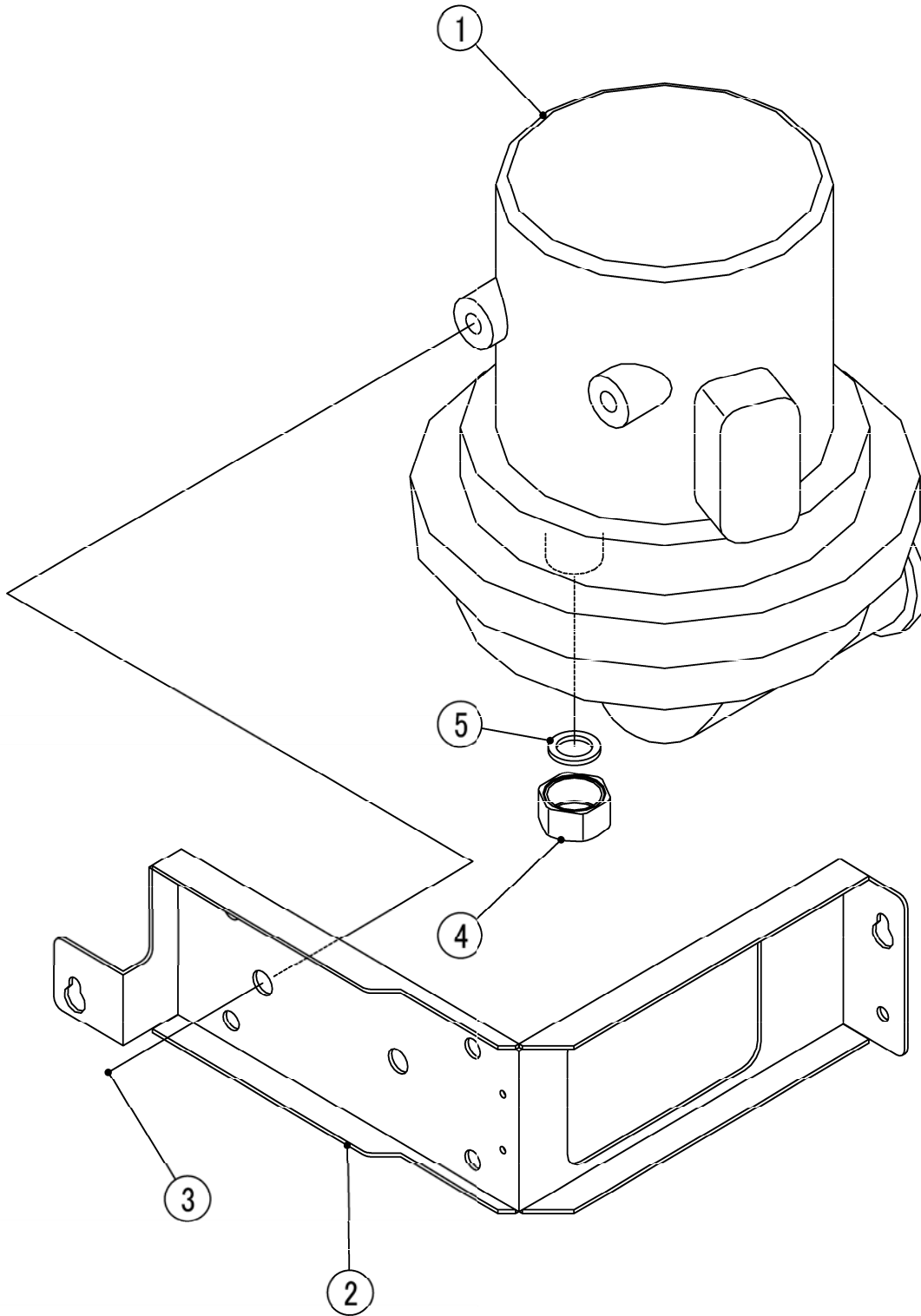

HA

| MODEL : JWE-2400CUA-L-25B | | | | | | | | TITLE : J. WASH PUMP (A) ASSY | | | |
|----------------------------------|-------------------------------|--------------------------|-------------|--------------|-----|--|--|--------------------------------------|--|--|--|
| INDEX NO. | DESCRIPTION | MATERIAL OR MODEL NUMBER | PART NUMBER | REQ'D NUMBER | | | | | | | |
| | | | | A-1 B-0 | B-1 | | | | | | |
| 1 | PUMP MOTOR | 50LPS-3756HUL | P01548-01 | 1 | 1 | | | | | | |
| 2 | SUPPORT (A) / WASH PUMP MOTOR | S.S | 3Y2246M02 | 1 | 1 | | | | | | |
| 3 | HEX HEAD BOLT W/ WASHERS | S.S | FBK1016S0 | 2 | 2 | | | | | | |
| 4 | NUT / WASH PUMP MOTOR | S.S | 4Y4183M01 | 1 | 1 | | | | | | |
| 5 | PACKING - TUBE | | 4H9792-01 | 1 | 1 | | | | | | |
| | | | | | | | | | | | |
| | | | | | | | | | | | |
| | | | | | | | | | | | |
| | | | | | | | | | | | |
| | | | | | | | | | | | |
| | | | | | | | | | | | |
| | | | | | | | | | | | |
| | | | | | | | | | | | |
| | | | | | | | | | | | |
| | | | | | | | | | | | |
| | | | | | | | | | | | |
| | | | | | | | | | | | |
| | | | | | | | | | | | |
| | | | | | | | | | | | |
| | | | | | | | | | | | |
| | | | | | | | | | | | |
| | | | | | | | | | | | |
| | | | | | | | | | | | |
| | | | | | | | | | | | |
| | | | | | | | | | | | |
| | | | | | | | | | | | |
| | | | | | | | | | | | |
| | | | | | | | | | | | |

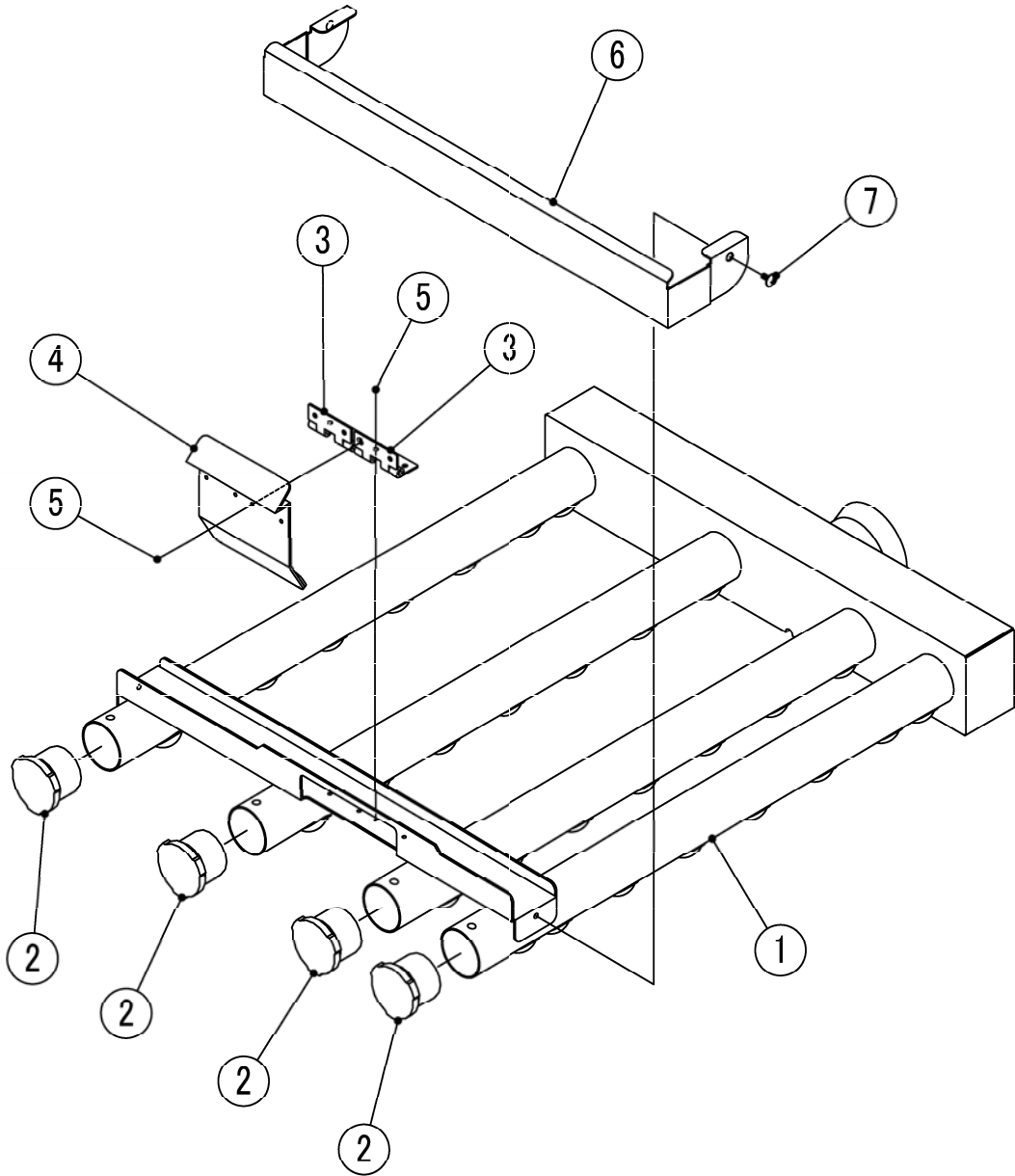

HA

| MODEL : JWE-2400CUA-L-25B | | | | TITLE : K. SPRAY ARM (UP) ASSY | | | |
|----------------------------------|-----------------------|--------------------------|-------------|---------------------------------------|-----|--|--|
| INDEX NO. | DESCRIPTION | MATERIAL OR MODEL NUMBER | PART NUMBER | REQ'D NUMBER | | | |
| | | | | A-1 B-0 | B-1 | | |
| 1 | WASH SPRAY ARM (UP) | S.S | 2H8389G01 | 1 | 1 | | |
| 2 | CAP - SPRAY ARM | POM | 3X1245-01 | 4 | 4 | | |
| 3 | HINGE | S.S | 443721-02 | 2 | 2 | | |
| 4 | HOOK - SPRAY ARM (UP) | S.S | 4Y4168M02 | 1 | 1 | | |
| 5 | SCREW | S.S | 4Y4752M01 | 8 | 8 | | |
| 6 | COVER - CAP (UP) | S.S | 4Y4836M02 | 1 | 1 | | |
| 7 | SCREW - TRUSS | S.S | 441582-04 | 2 | 2 | | |
| | | | | | | | |
| | | | | | | | |
| | | | | | | | |
| | | | | | | | |
| | | | | | | | |
| | | | | | | | |
| | | | | | | | |
| | | | | | | | |
| | | | | | | | |
| | | | | | | | |
| | | | | | | | |
| | | | | | | | |
| | | | | | | | |
| | | | | | | | |
| | | | | | | | |
| | | | | | | | |
| | | | | | | | |
| | | | | | | | |
| | | | | | | | |
| | | | | | | | |
| | | | | | | | |
| | | | | | | | |

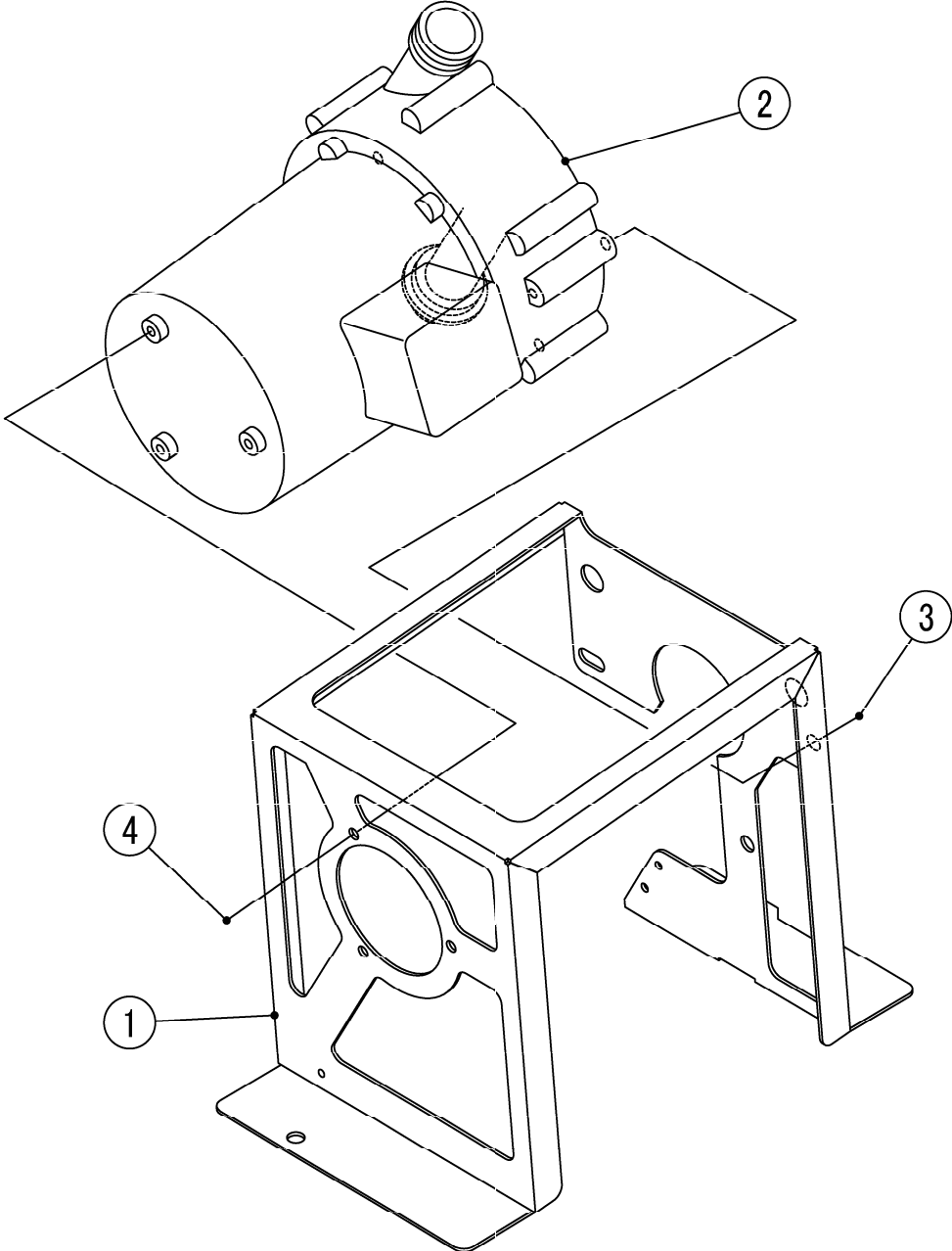

HA

| MODEL : JWE-2400CUA-L-25B | | TITLE : L. RINSE PUMP ASSY | | | | | |
|----------------------------------|-----------------------------------|-----------------------------------|-------------|--------------|-----|--|--|
| INDEX NO. | DESCRIPTION | MATERIAL OR MODEL NUMBER | PART NUMBER | REQ'D NUMBER | | | |
| | | | | A-1 B-0 | B-1 | | |
| 1 | BRACKET - RINSE PUMP MOTOR | S.S | 2H8161M02 | 1 | 1 | | |
| 2 | PUMP MOTOR | PMD-1023BHZ4 | P01834-01 | 1 | 1 | | |
| 3 | PAN HEAD MACHINE SCREW W/ WASHERS | S.S | P01834F01 | 3 | 3 | | |
| 4 | HEX HEAD BOLT W/ WASHERS | S.S | FBK0406S0 | 3 | 3 | | |
| | | | | | | | |
| | | | | | | | |
| | | | | | | | |
| | | | | | | | |
| | | | | | | | |
| | | | | | | | |
| | | | | | | | |
| | | | | | | | |
| | | | | | | | |
| | | | | | | | |
| | | | | | | | |
| | | | | | | | |
| | | | | | | | |
| | | | | | | | |
| | | | | | | | |
| | | | | | | | |
| | | | | | | | |
| | | | | | | | |
| | | | | | | | |
| | | | | | | | |
| | | | | | | | |
| | | | | | | | |
| | | | | | | | |
| | | | | | | | |
| | | | | | | | |
| | | | | | | | |
| | | | | | | | |
| | | | | | | | |

M. CRANK UNIT ASSY

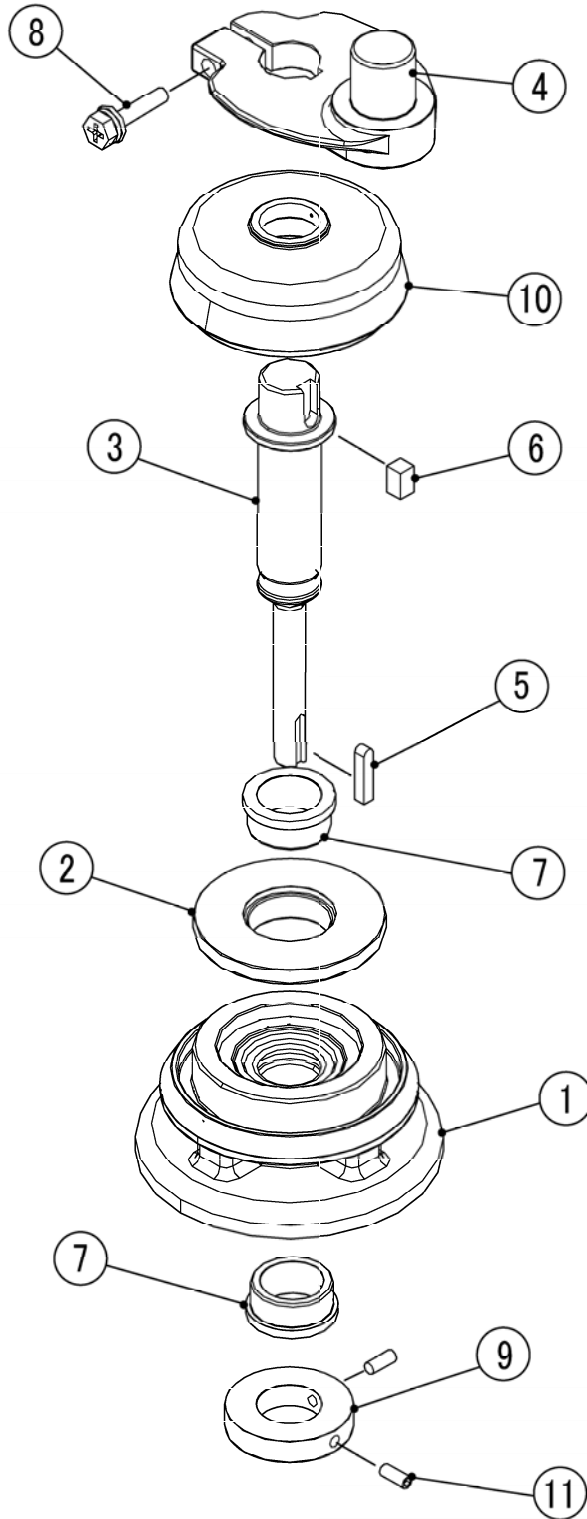

HA

| MODEL : JWE-2400CUA-L-25B | | TITLE : M. CRANK UNIT ASSY | | | | | |
|---------------------------|-----------------------------------|----------------------------|-------------|--------------|-----|--|--|
| INDEX NO. | DESCRIPTION | MATERIAL OR MODEL NUMBER | PART NUMBER | REQ'D NUMBER | | | |
| | | | | A-1 B-0 | B-1 | | |
| 1 | HOUSING | S.S | 3Y5638A01 | 1 | 1 | | |
| 2 | HOUSING (UP) | S.S | 4Y7048M01 | 1 | 1 | | |
| 3 | CRANKSHAFT | S.S | 4Y7050M01 | 1 | 1 | | |
| 4 | CRANK ARM (A) | S.S | 3Y5448M01 | 1 | 1 | | |
| 5 | KEY | S.S | 4Y4787M01 | 1 | 1 | | |
| 6 | KEY | S.S | 4Y4185M02 | 1 | 1 | | |
| 7 | SLEEVE BEARING | PPS | 4Y3237-05 | 2 | 2 | | |
| 8 | HEX HEAD BOLT W/ WASHERS | S.S | FBK0625S1 | 1 | 1 | | |
| 9 | STOPPER - CRANKSHAFT | S.S | 4Y7260M01 | 1 | 1 | | |
| 10 | COVER - HOUSING | PE | 3Y5450P01 | 1 | 1 | | |
| 11 | HEX SOCKET SET SCREW (FLAT POINT) | S.S | FSC0510S0 | 2 | 2 | | |
| | | | | | | | |
| | | | | | | | |
| | | | | | | | |
| | | | | | | | |
| | | | | | | | |
| | | | | | | | |
| | | | | | | | |
| | | | | | | | |
| | | | | | | | |
| | | | | | | | |
| | | | | | | | |
| | | | | | | | |
| | | | | | | | |
| | | | | | | | |
| | | | | | | | |
| | | | | | | | |
| | | | | | | | |
| | | | | | | | |
| | | | | | | | |
| | | | | | | | |
| | | | | | | | |
| | | | | | | | |

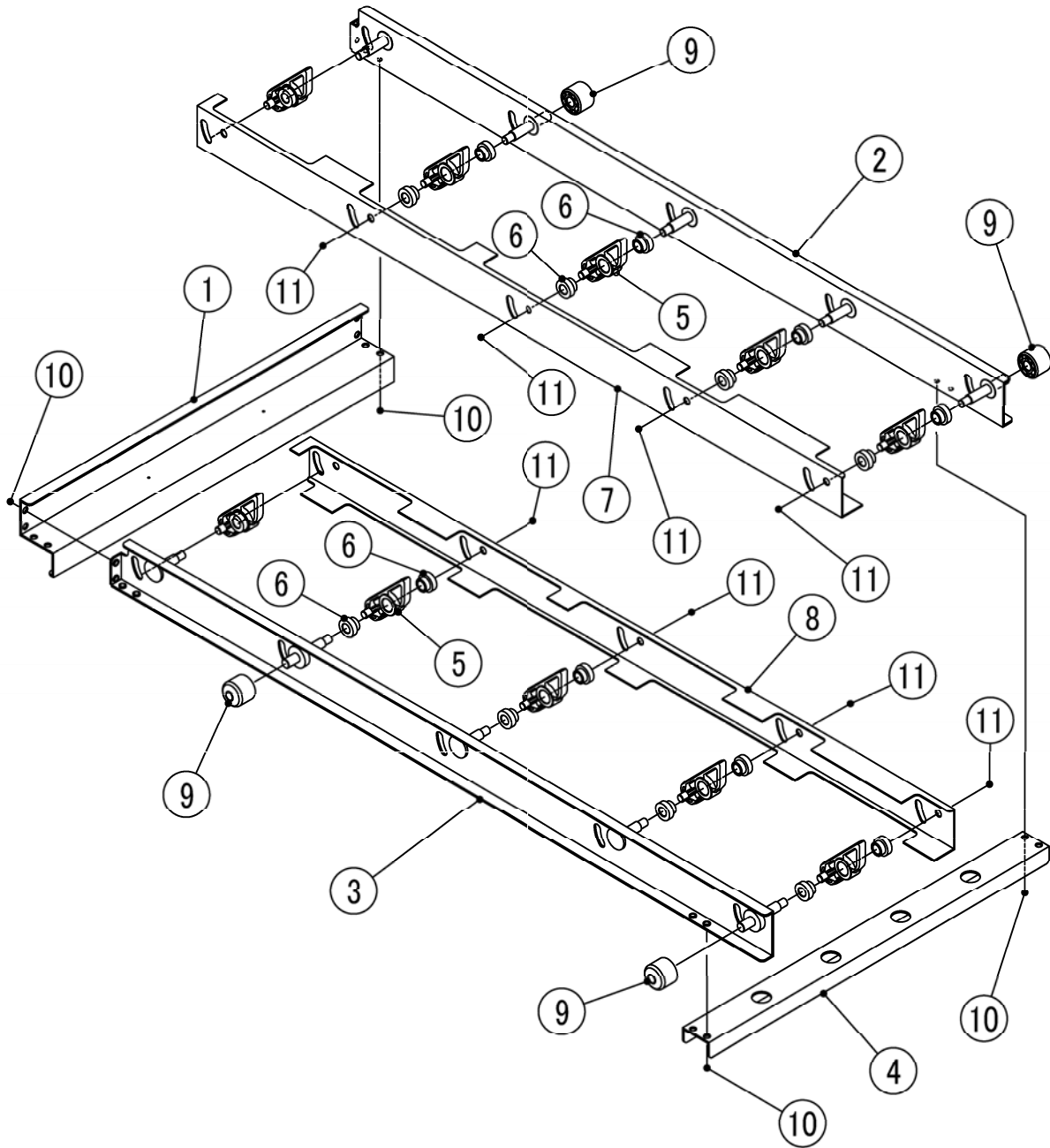

HA

| MODEL : JWE-2400CUA-L-25B | | | | TITLE : N. CONVEYOR RAIL ASSY | | | |
|---------------------------|---------------------------|--------------------------|-------------|-------------------------------|-----|--|--|
| INDEX NO. | DESCRIPTION | MATERIAL OR MODEL NUMBER | PART NUMBER | REQ'D NUMBER | | | |
| | | | | A-1 B-0 | B-1 | | |
| 1 | FRAME (A) - CONVEYOR RAIL | S.S | 3Y2241G02 | 1 | 1 | | |
| 2 | CONVEYOR RAIL (A) | S.S | 3Y4834G02 | 1 | 1 | | |
| 3 | CONVEYOR RAIL (B) | S.S | 3Y4835G02 | 1 | 1 | | |
| 4 | FRAME (B) - CONVEYOR RAIL | S.S | 3Y2242M02 | 1 | 1 | | |
| 5 | HOOK - CONVEYOR | S.S | 3Y2221M01 | 10 | 10 | | |
| 6 | SLEEVE (A) - HOOK | PE | 4Y4136P01 | 20 | 20 | | |
| 7 | GUIDE (A) - CONVEYOR RAIL | S.S | 2H9852M02 | 1 | 1 | | |
| 8 | GUIDE (B) - CONVEYOR RAIL | S.S | 2H9853M02 | 1 | 1 | | |
| 9 | ROLLER - CONVEYOR RAIL | PE | 4Y4137P01 | 4 | 4 | | |
| 10 | SCREW - BOLT | S.S | 449879-03 | 12 | 12 | | |
| 11 | CAPPED U NUT | S.S | FNC108S0 | 10 | 10 | | |
| 12 | GUAID - FLAME | PE | 4Y4439P01 | 2 | 2 | | |
| 13 | TRUSS HEAD MACHINE SCREW | S.S | FST0408S0 | 2 | 2 | | |
| | | | | | | | |
| | | | | | | | |
| | | | | | | | |
| | | | | | | | |
| | | | | | | | |
| | | | | | | | |
| | | | | | | | |
| | | | | | | | |
| | | | | | | | |
| | | | | | | | |
| | | | | | | | |
| | | | | | | | |
| | | | | | | | |
| | | | | | | | |
| | | | | | | | |
| | | | | | | | |
| | | | | | | | |
| | | | | | | | |
| | | | | | | | |

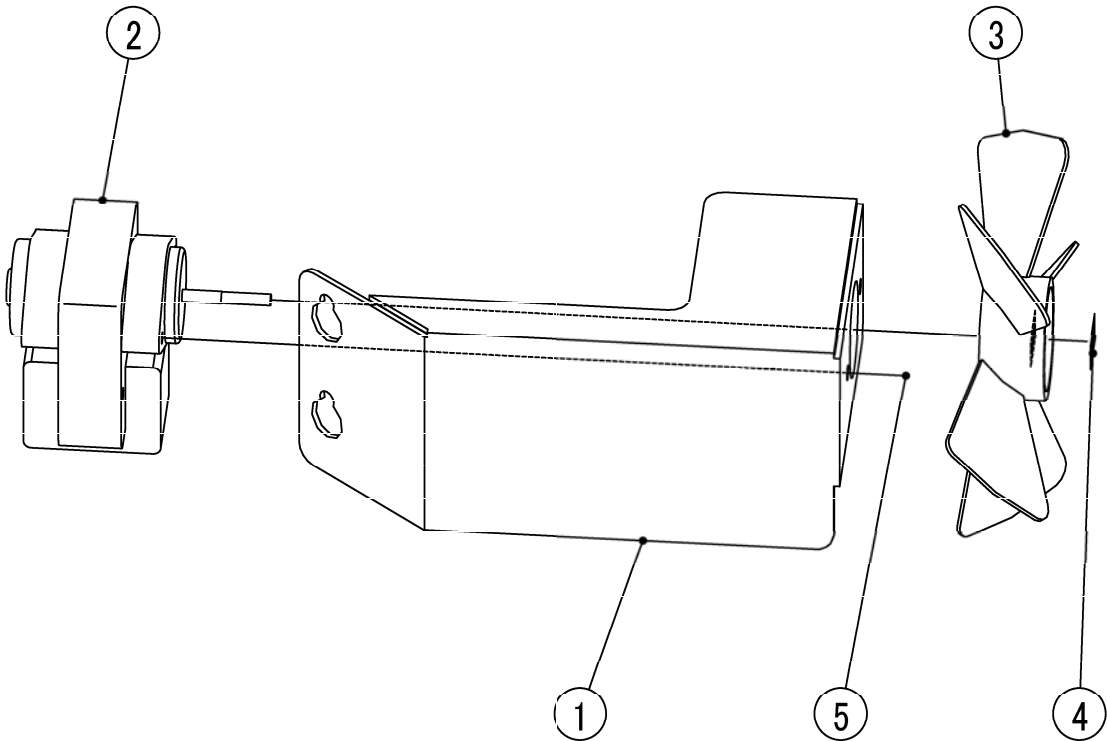

HA

| MODEL : JWE-2400CUA-L-25B TITLE : P. FAN MOTOR ASSY | | | | | | | |
|---|--------------------------------------|--------------------------|-------------|--------------|-----|--|--|
| INDEX NO. | DESCRIPTION | MATERIAL OR MODEL NUMBER | PART NUMBER | REQ'D NUMBER | | | |
| | | | | A-1 B-0 | B-1 | | |
| 1 | BRACKET (A) - FAN MOTOR | S.S | 4Y4328M02 | 1 | 1 | | |
| 2 | FAN MOTOR | F3042R | P01203-01 | 1 | 1 | | |
| 3 | FAN | PP | 449942-01 | 1 | 1 | | |
| 4 | SPEED NUT | S.S | 449942F01 | 1 | 1 | | |
| 5 | PAN HEAD MACHINE SCREW W/ WASHERS | S.S | FSK0306S0 | 2 | 2 | | |
| | | | | | | | |
| | | | | | | | |
| | | | | | | | |
| | | | | | | | |
| | | | | | | | |
| | | | | | | | |
| | | | | | | | |
| | | | | | | | |
| | | | | | | | |
| | | | | | | | |
| | | | | | | | |
| | | | | | | | |
| | | | | | | | |
| | | | | | | | |
| | | | | | | | |
| | | | | | | | |
| | | | | | | | |
| | | | | | | | |
| | | | | | | | |
| | | | | | | | |
| | | | | | | | |
| | | | | | | | |
| | | | | | | | |
| | | | | | | | |
| | | | | | | | |
| | | | | | | | |
| | | | | | | | |
| | | | | | | | |

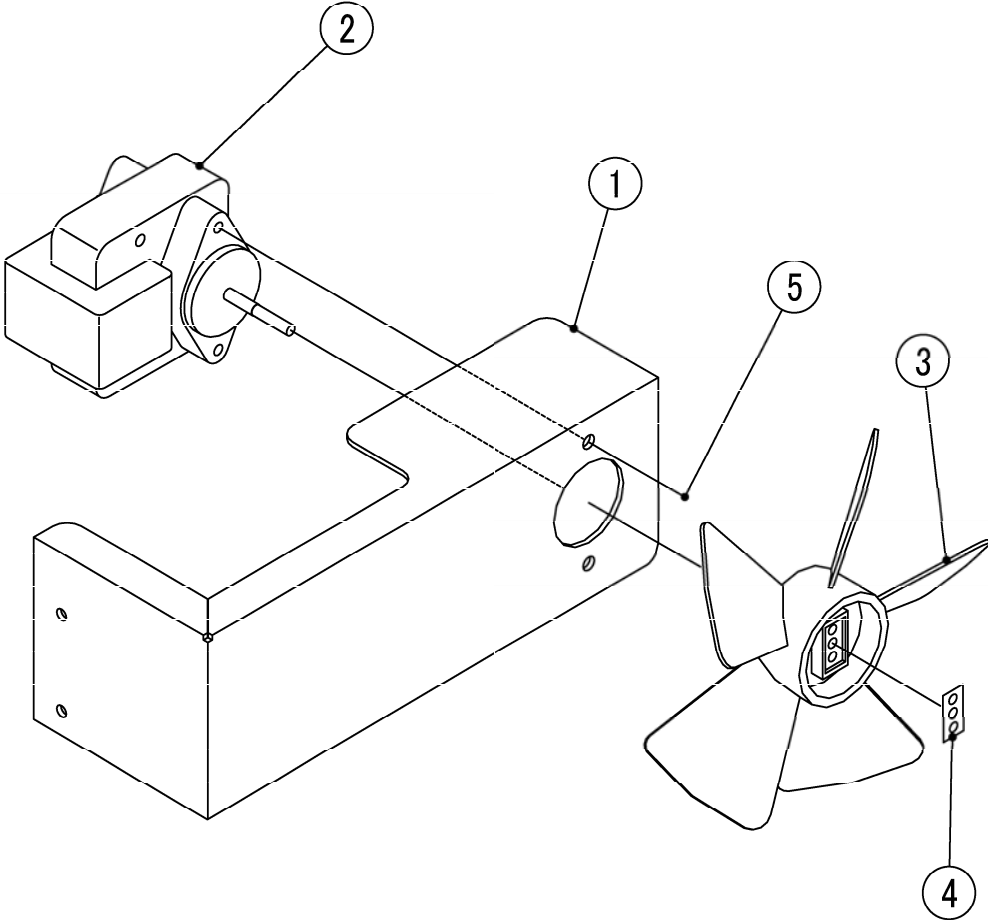

HA

| MODEL : JWE-2400CUA-L-25B TITLE : Q. FAN MOTOR (B) ASSY | | | | | | | |
|---|--------------------------------------|--------------------------|-------------|--------------|-----|--|--|
| INDEX NO. | DESCRIPTION | MATERIAL OR MODEL NUMBER | PART NUMBER | REQ'D NUMBER | | | |
| | | | | A-1 B-0 | B-1 | | |
| 1 | BRACKET (B) - FAN MOTOR | S.S | 4Y4329M02 | 1 | 1 | | |
| 2 | FAN MOTOR | F3042R | P01203-01 | 1 | 1 | | |
| 3 | FAN | PP | 449942-01 | 1 | 1 | | |
| 4 | SPEED NUT | S.S | 449942F01 | 1 | 1 | | |
| 5 | PAN HEAD MACHINE SCREW W/ WASHERS | S.S | FSK0306S0 | 2 | 2 | | |
| | | | | | | | |
| | | | | | | | |
| | | | | | | | |
| | | | | | | | |
| | | | | | | | |
| | | | | | | | |
| | | | | | | | |
| | | | | | | | |
| | | | | | | | |
| | | | | | | | |
| | | | | | | | |
| | | | | | | | |
| | | | | | | | |
| | | | | | | | |
| | | | | | | | |
| | | | | | | | |
| | | | | | | | |
| | | | | | | | |
| | | | | | | | |
| | | | | | | | |
| | | | | | | | |
| | | | | | | | |
| | | | | | | | |
| | | | | | | | |
| | | | | | | | |
| | | | | | | | |
| | | | | | | | |
| | | | | | | | |
| | | | | | | | |
| | | | | | | | |
| | | | | | | | |
| | | | | | | | |
| | | | | | | | |
| | | | | | | | |
| | | | | | | | |

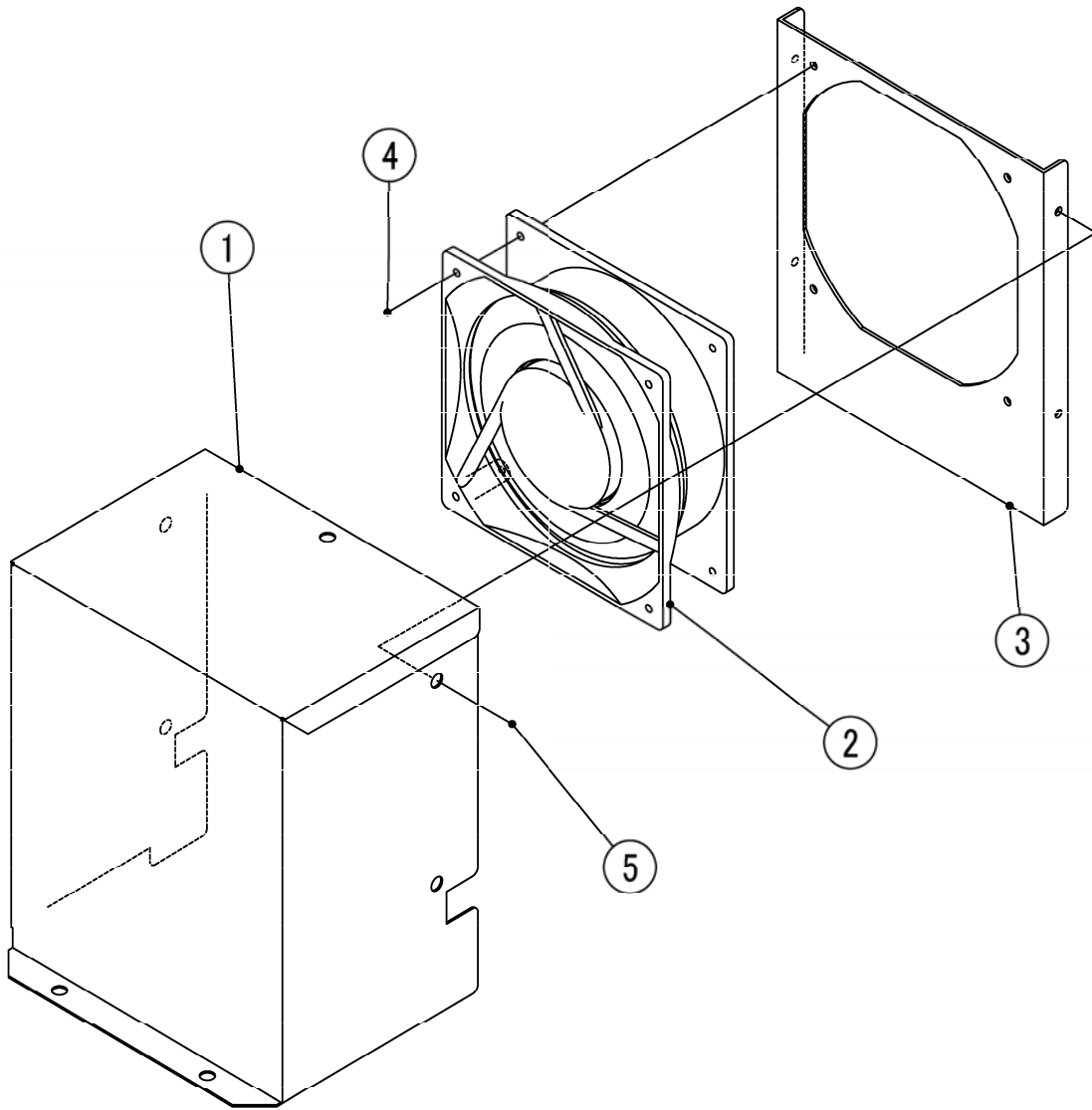

HA

| MODEL : JWE-2400CUA-L-25B | | TITLE : R. FAN MOTOR (C) ASSY | | | | | |
|---------------------------|--------------------------|-------------------------------|-------------|--------------|-----|--|--|
| INDEX NO. | DESCRIPTION | MATERIAL OR MODEL NUMBER | PART NUMBER | REQ'D NUMBER | | | |
| | | | | A-1 B-0 | B-1 | | |
| 1 | DUCT - FAN MOTOR | S.S | 3Y5061M01 | 1 | 1 | | |
| 2 | FAN MOTOR | CN60B5 | P01836-01 | 1 | 1 | | |
| 3 | BRACKET - FAN MOTOR | S.S | 3Y5378M01 | 1 | 1 | | |
| 4 | TRUSS HEAD MACHINE SCREW | S.S | FST0445S0 | 4 | 4 | | |
| 5 | HEX HEAD BOLT W/ WASHERS | S.S | FBK0408S0 | 4 | 4 | | |
| | | | | | | | |
| | | | | | | | |
| | | | | | | | |
| | | | | | | | |
| | | | | | | | |
| | | | | | | | |
| | | | | | | | |
| | | | | | | | |
| | | | | | | | |
| | | | | | | | |
| | | | | | | | |
| | | | | | | | |
| | | | | | | | |
| | | | | | | | |
| | | | | | | | |
| | | | | | | | |
| | | | | | | | |
| | | | | | | | |
| | | | | | | | |
| | | | | | | | |
| | | | | | | | |
| | | | | | | | |
| | | | | | | | |
| | | | | | | | |

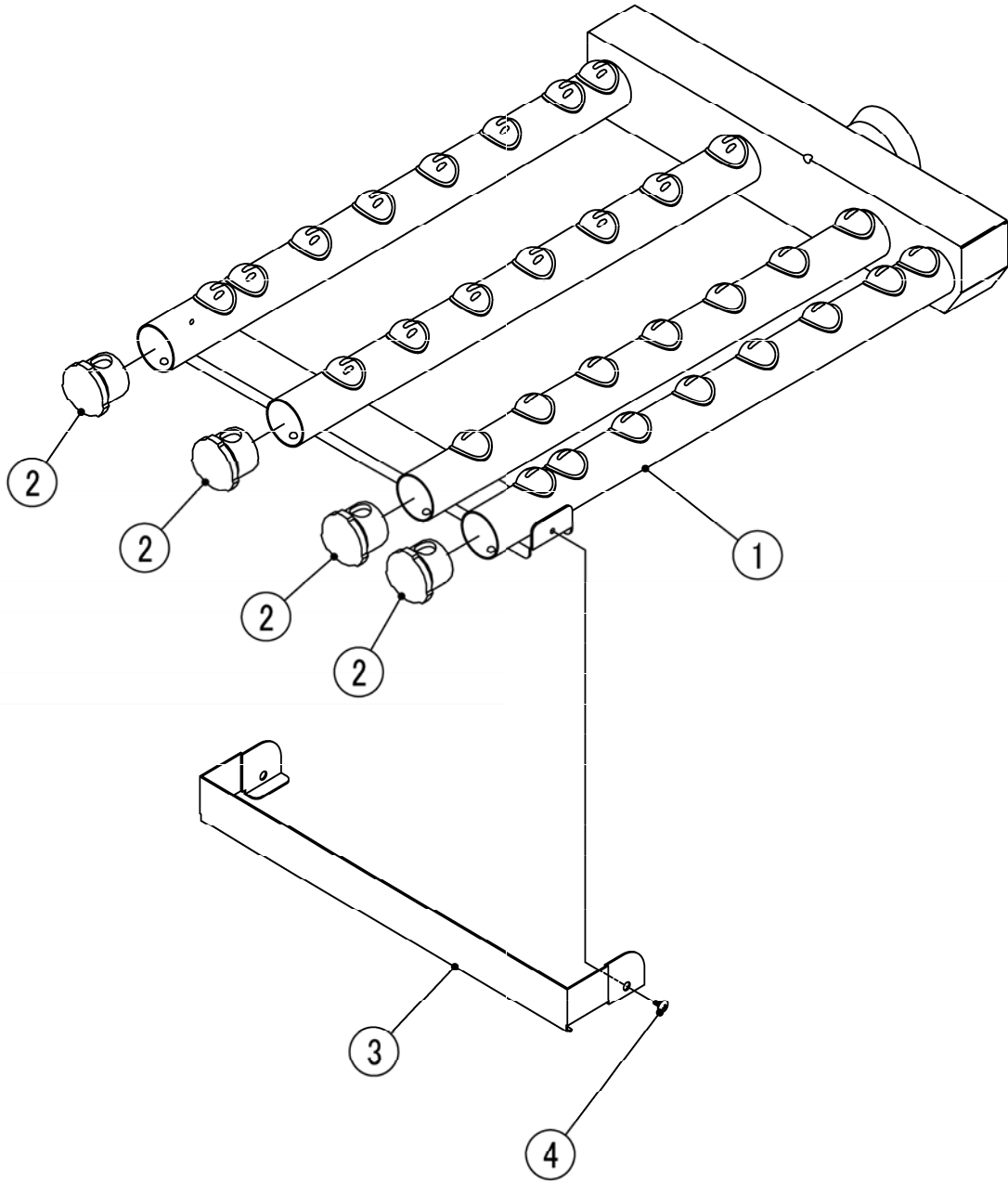

HA

| MODEL : JWE-2400CUA-L-25B | | TITLE : S. SPRAY ARM (LO) ASSY | | | | | |
|----------------------------------|---------------------|---------------------------------------|-------------|--------------|-----|--|--|
| INDEX NO. | DESCRIPTION | MATERIAL OR MODEL NUMBER | PART NUMBER | REQ'D NUMBER | | | |
| | | | | A-1 B-0 | B-1 | | |
| 1 | WASH SPRAY ARM (LO) | S.S | 2H8390G01 | 1 | 1 | | |
| 2 | CAP - SPRAY ARM | POM | 3X1245-01 | 4 | 4 | | |
| 3 | COVER - CAP (LO) | S.S | 4Y4835M02 | 1 | 1 | | |
| 4 | SCREW - TRUSS | S.S | 441582-04 | 2 | 2 | | |
| | | | | | | | |
| | | | | | | | |
| | | | | | | | |
| | | | | | | | |
| | | | | | | | |
| | | | | | | | |
| | | | | | | | |
| | | | | | | | |
| | | | | | | | |
| | | | | | | | |
| | | | | | | | |
| | | | | | | | |
| | | | | | | | |
| | | | | | | | |
| | | | | | | | |
| | | | | | | | |
| | | | | | | | |
| | | | | | | | |
| | | | | | | | |
| | | | | | | | |
| | | | | | | | |
| | | | | | | | |
| | | | | | | | |
| | | | | | | | |
| | | | | | | | |
| | | | | | | | |
| | | | | | | | |
| | | | | | | | |
| | | | | | | | |
| | | | | | | | |
| | | | | | | | |
| | | | | | | | |
| | | | | | | | |
| | | | | | | | |
| | | | | | | | |
| | | | | | | | |
| | | | | | | | |
| | | | | | | | |
| | | | | | | | |
| | | | | | | | |
| | | | | | | | |
| | | | | | | | |

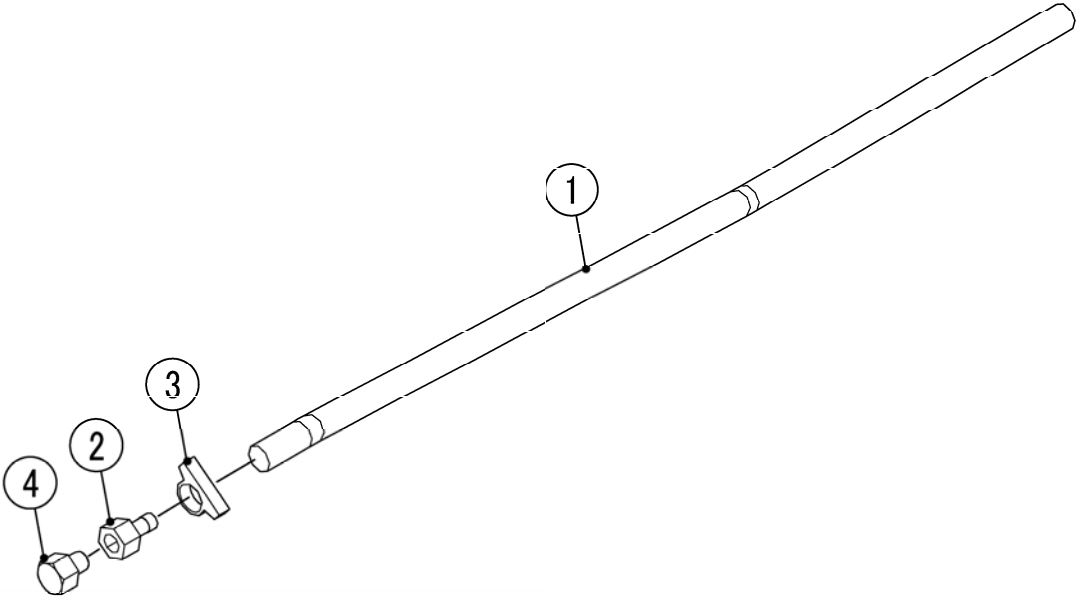

HA

| MODEL : JWE-2400CUA-L-25B | | | | | | | | TITLE : T. HOSE - CLEANSER ASSY | | | | | | | |
|----------------------------------|--------------------|--------------------------|-------------|--------------|-----|--|--|--|--|--|--|--|--|--|--|
| INDEX NO. | DESCRIPTION | MATERIAL OR MODEL NUMBER | PART NUMBER | REQ'D NUMBER | | | | | | | | | | | |
| | | | | A-1 B-0 | B-1 | | | | | | | | | | |
| 1 | HOSE - CLEANSER | SI.R | 4H8168-07 | 1 | 1 | | | | | | | | | | |
| 2 | JOINT - RINSE PUMP | | 4X0889-01 | 1 | 1 | | | | | | | | | | |
| 3 | HOSE CLAMP | SNP-7 | 435947-01 | 1 | 1 | | | | | | | | | | |
| 4 | RINSE PLUG | | 4X8858-01 | 1 | 1 | | | | | | | | | | |
| | | | | | | | | | | | | | | | |
| | | | | | | | | | | | | | | | |
| | | | | | | | | | | | | | | | |
| | | | | | | | | | | | | | | | |
| | | | | | | | | | | | | | | | |
| | | | | | | | | | | | | | | | |
| | | | | | | | | | | | | | | | |
| | | | | | | | | | | | | | | | |
| | | | | | | | | | | | | | | | |
| | | | | | | | | | | | | | | | |
| | | | | | | | | | | | | | | | |
| | | | | | | | | | | | | | | | |
| | | | | | | | | | | | | | | | |
| | | | | | | | | | | | | | | | |
| | | | | | | | | | | | | | | | |
| | | | | | | | | | | | | | | | |
| | | | | | | | | | | | | | | | |
| | | | | | | | | | | | | | | | |
| | | | | | | | | | | | | | | | |
| | | | | | | | | | | | | | | | |
| | | | | | | | | | | | | | | | |
| | | | | | | | | | | | | | | | |
| | | | | | | | | | | | | | | | |
| | | | | | | | | | | | | | | | |

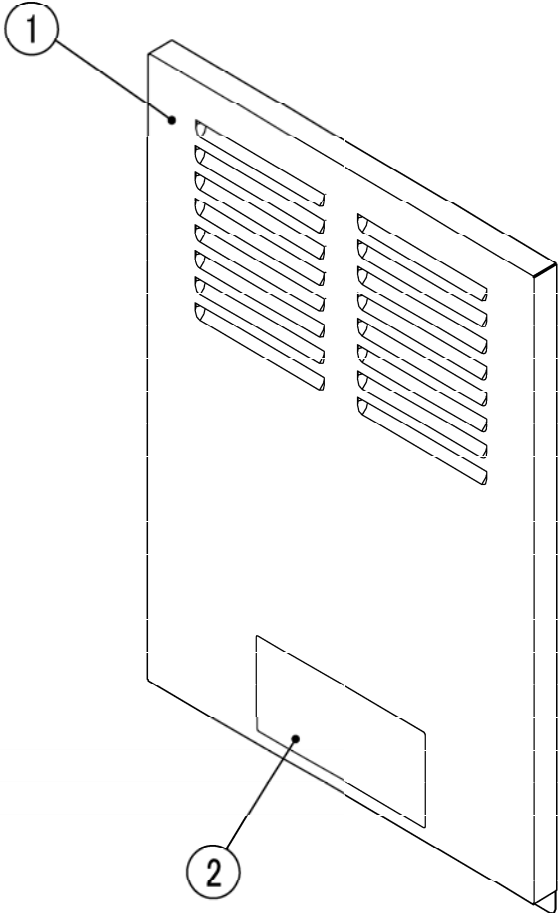

HA

| MODEL : JWE-2400CUA-L-25B TITLE : U. FRONT PANEL - BOOSTER | | | | | | | |
|---|-------------------------|--------------------------|-------------|--------------|-----|--|--|
| INDEX NO. | DESCRIPTION | MATERIAL OR MODEL NUMBER | PART NUMBER | REQ'D NUMBER | | | |
| | | | | A-1 B-0 | B-1 | | |
| 1 | FRONT PANEL - BOOSTER | S.S | 2H9954M01 | 1 | 1 | | |
| 2 | WARNING LABEL - SERVICE | | 472727L01 | 1 | 1 | | |
| | | | | | | | |
| | | | | | | | |
| | | | | | | | |
| | | | | | | | |
| | | | | | | | |
| | | | | | | | |
| | | | | | | | |
| | | | | | | | |
| | | | | | | | |
| | | | | | | | |
| | | | | | | | |
| | | | | | | | |
| | | | | | | | |
| | | | | | | | |
| | | | | | | | |
| | | | | | | | |
| | | | | | | | |
| | | | | | | | |
| | | | | | | | |
| | | | | | | | |
| | | | | | | | |
| | | | | | | | |
| | | | | | | | |
| | | | | | | | |
| | | | | | | | |
| | | | | | | | |
| | | | | | | | |
| | | | | | | | |
| | | | | | | | |
| | | | | | | | |
| | | | | | | | |

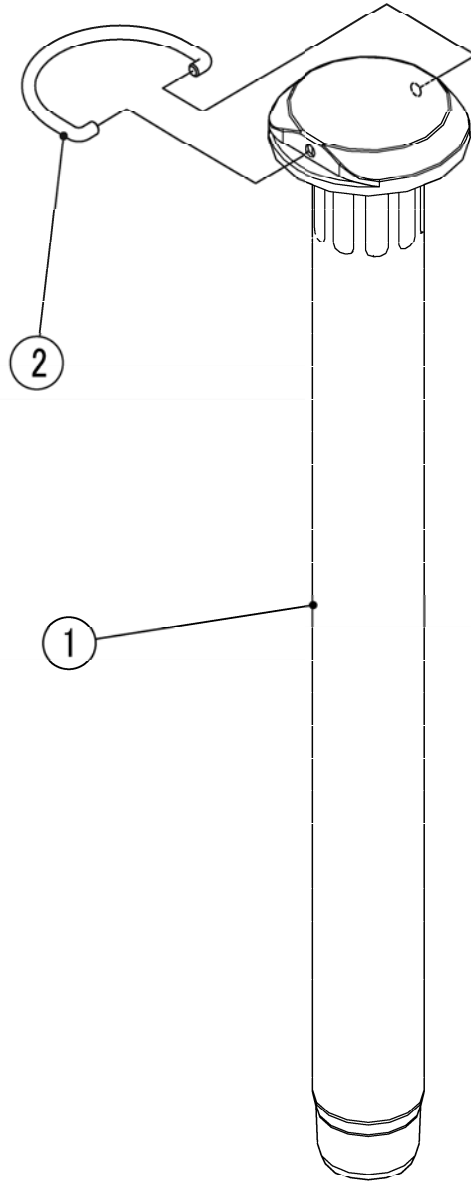

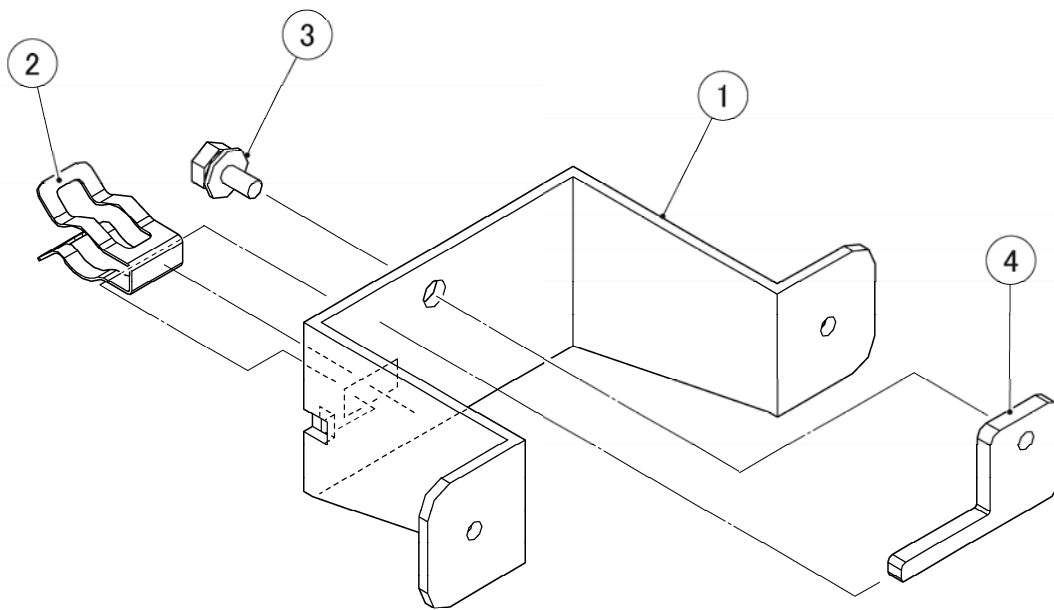

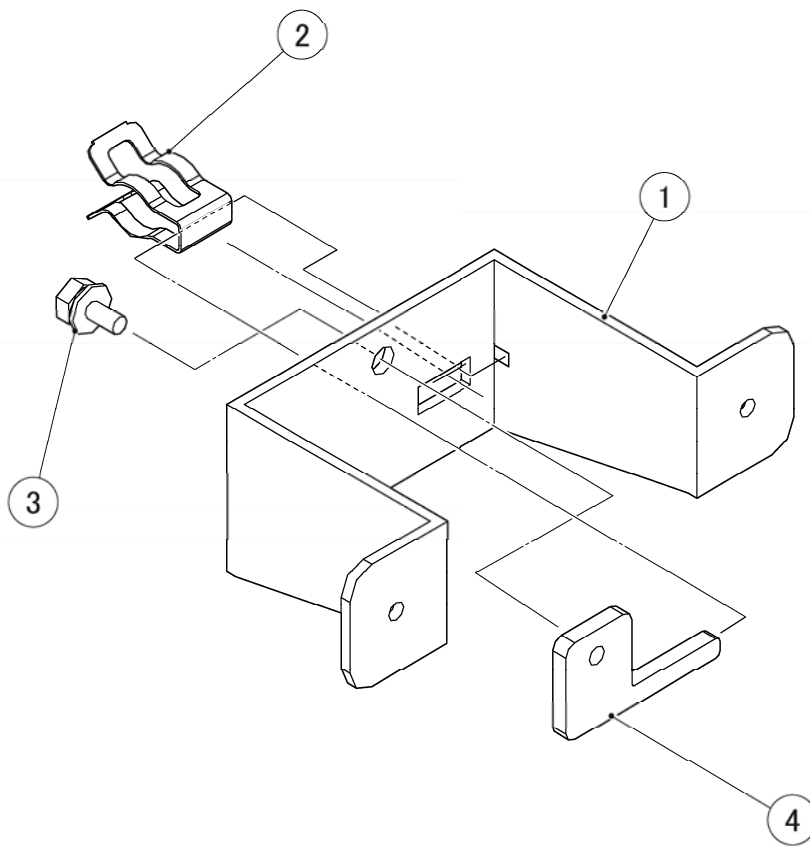

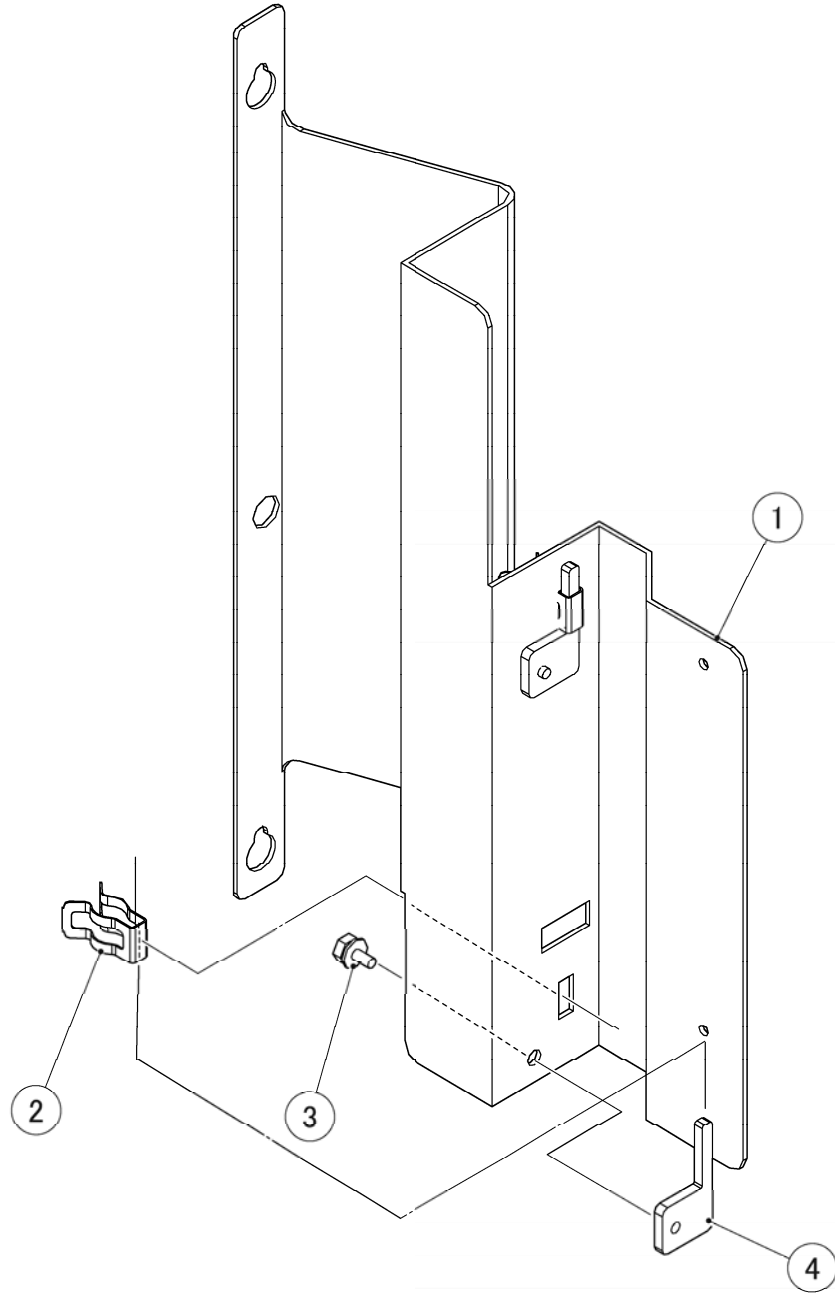

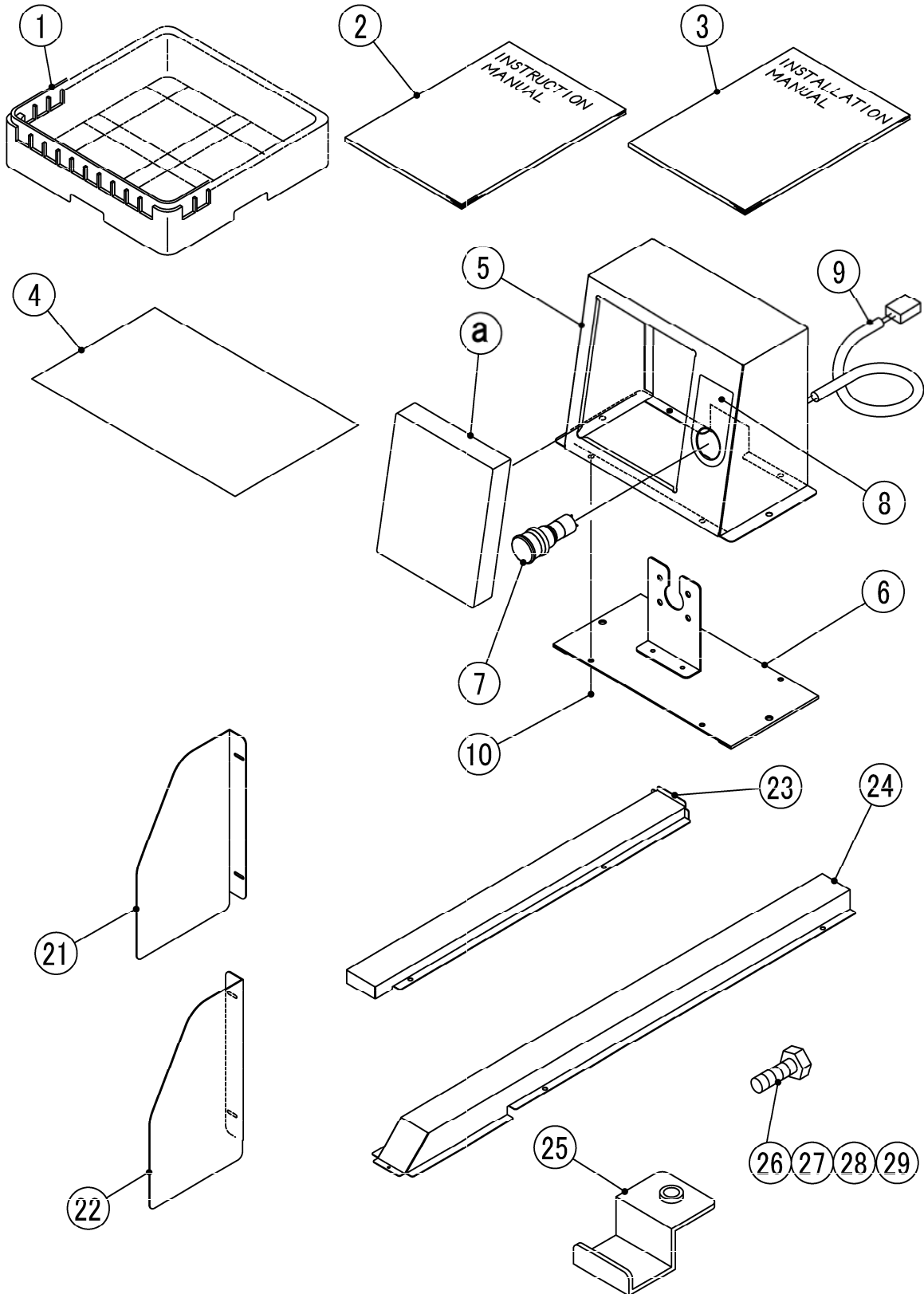

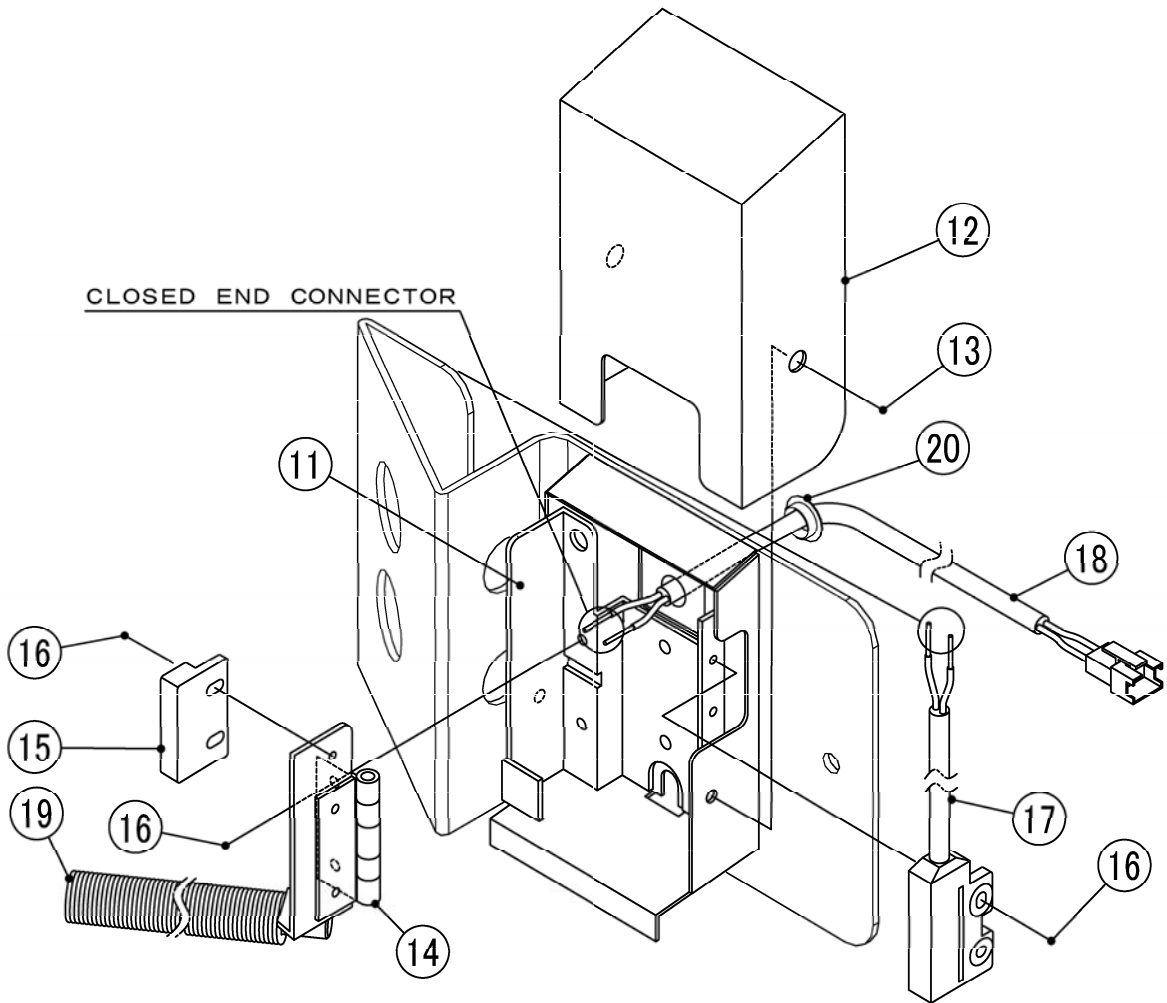

HA

| MODEL : JWE-2400CUA-L-25B TITLE : Z. ACCESSORIES | | | | | | | |
|--|--------------------------------------|--------------------------|-------------|--------------|-----|--|--|
| INDEX NO. | DESCRIPTION | MATERIAL OR MODEL NUMBER | PART NUMBER | REQ'D NUMBER | | | |
| | | | | A-1 B-0 | B-1 | | |
| a | OPERATION PANEL ASSY | - | 2H9959A01 | 1 | 1 | | |
| 1 | RACK | PP | 1H0790-01 | 1 | 1 | | |
| 2 | INSTRUCTION MANUAL | | L1J002111 | 1 | 1 | | |
| 3 | INSTALLATION MANUAL | | L2J002111 | 1 | 1 | | |
| 4 | MAINTENANCE SHEET | | 258202L01 | 1 | 1 | | |
| 5 | OPERATION BOX (A-L) | S.S | 3Y5053G01 | 1 | 1 | | |
| 6 | COVER - OPERATION BOX (A-L) | S.S | 4Y6609G01 | 1 | 1 | | |
| 7 | EMERGENCY STOP BUTTON | HN1E-BV402R | 463704-01 | 1 | 1 | | |
| 8 | LABEL - EMERGENCY STOP | | 474704L01 | 1 | 1 | | |
| 9 | CABLE - EMERGENCY STOP | | 4Y7053A01 | 1 | 1 | | |
| 10 | SCREW | S.S | 4Y1319-01 | 4 | 4 | | |
| 11 | BOX - TABLE LIMIT SWITCH | S.S | 3Y5062G01 | 1 | 1 | | |
| 12 | COVER - TABLE LIMIT SWITCH | S.S | 3Y2551M01 | 1 | 1 | | |
| 13 | TRUSS HEAD MACHINE SCREW | S.S | FST0408S0 | 2 | 2 | | |
| 14 | BRACKET (L) - MAGNET | S.S | 4Y4387G01 | 1 | 1 | | |
| 15 | MAGNET | | 436974-01 | 1 | 1 | | |
| 16 | PAN HEAD MACHINE SCREW W/ WASHERS | S.S | FSK0308S0 | 6 | 6 | | |
| 17 | REED SWITCH | PS-0074-502B | 453861-02 | 1 | 1 | | |
| 18 | CABLE (B) - TABLE LIMIT SWITCH | | 4Y7054A01 | 1 | 1 | | |
| 19 | SPRING | S.S | 4Y6610M01 | 1 | 1 | | |
| 20 | BUSHING | SB-562-7 | 420470-09 | 1 | 1 | | |
| 21 | GUARD (L) | S.S | 3Y5063M01 | 1 | 1 | | |
| 22 | GUARD (R) | S.S | 3Y5064M01 | 1 | 1 | | |
| 23 | CABLE COVER (A) | S.S | 3Y5065G01 | 1 | 1 | | |
| 24 | CABLE COVER (B) | S.S | 2H9960G01 | 1 | 1 | | |
| 25 | HOOK - DRAIN | S.S | 4Y6611M01 | 1 | 1 | | |
| 26 | HEX HEAD BOLT W/ WASHERS | S.S | FBK0612S0 | 1 | 1 | | |
| 27 | HEX HEAD BOLT W/ WASHERS | S.S | FBK0512S0 | 3 | 3 | | |
| 28 | HEX HEAD BOLT W/ WASHERS | S.S | FNH105S0 | 3 | 3 | | |
| 29 | HEX HEAD BOLT W/ WASHERS | S.S | FBK0408S0 | 11 | 11 | | |
| | | | | | | | |
| | | | | | | | |

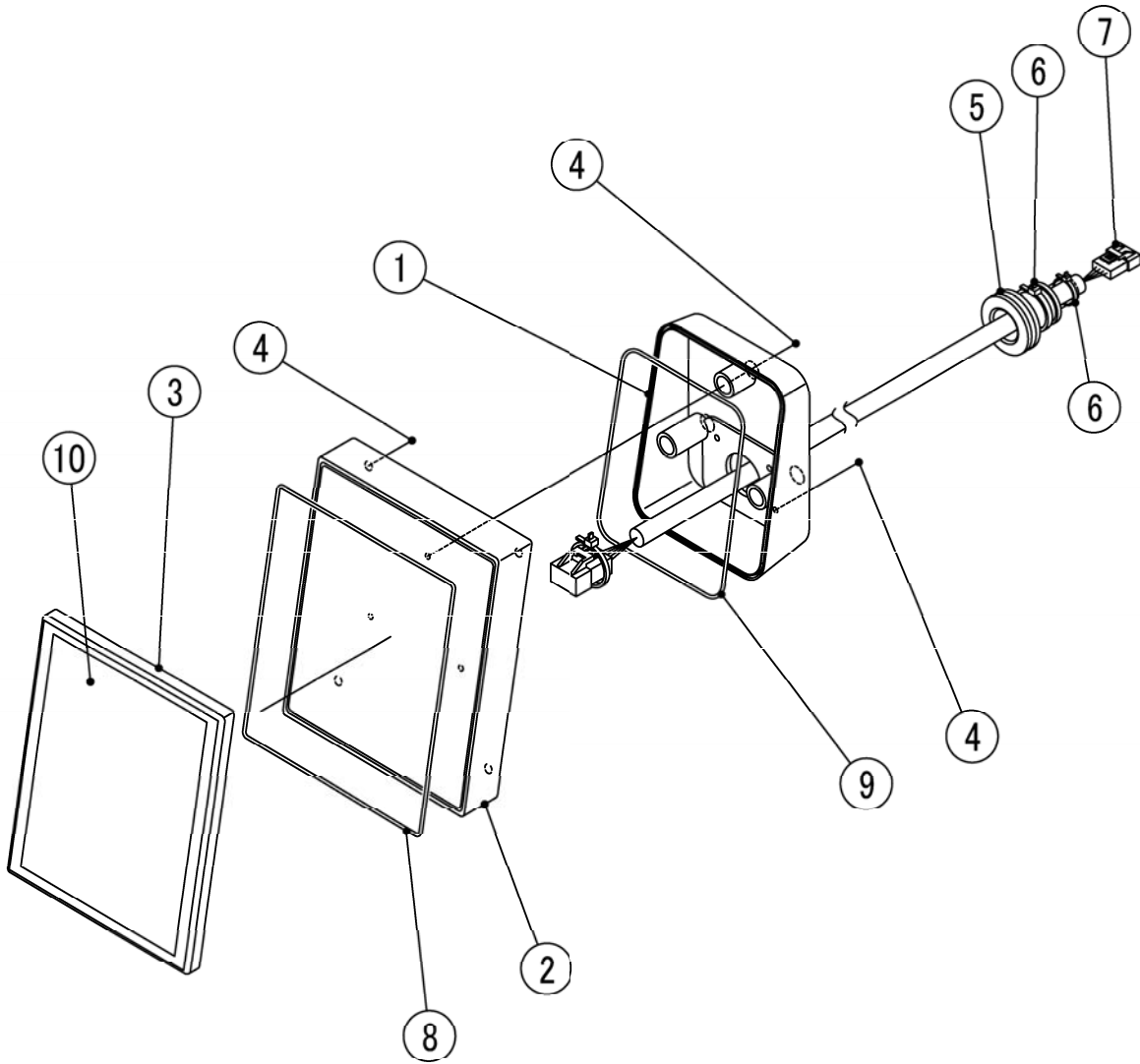

HA

| MODEL : JWE-2400CUA-L-25B | | TITLE : a. OPERATION PANEL ASSY | | | | | |
|----------------------------------|--------------------------|--|-------------|--------------|-----|--|--|
| INDEX NO. | DESCRIPTION | MATERIAL OR MODEL NUMBER | PART NUMBER | REQ'D NUMBER | | | |
| | | | | A-1 B-0 | B-1 | | |
| 1 | JOINT - OPERATION (B) | ABS | 2H4683-01 | 1 | 1 | | |
| 2 | OPERATION BOARD | HSTZZD0086 | P00999-01 | 1 | 1 | | |
| 3 | OPERATION PANEL (B) | ABS | 1H4359P01 | 1 | 1 | | |
| 4 | TRUSS HEAD TAPPING SCREW | S.S | FT20412M0 | 7 | 7 | | |
| 5 | GROMMET | NBR | 4H2568-01 | 1 | 1 | | |
| 6 | CABLE TIE | CV-100 | 7920-0002 | 1 | 1 | | |
| 7 | CABLE - OPERATION | | 3X4524A13 | 1 | 1 | | |
| 8 | TUBE (A) | SI.R | 2H9959-08 | 1 | 1 | | |
| 9 | TUBE (B) | SI.R | 2H9959-09 | 1 | 1 | | |
| 10 | OPERATION LABEL | | 373703L01 | 1 | 1 | | |
| | | | | | | | |
| | | | | | | | |
| | | | | | | | |
| | | | | | | | |
| | | | | | | | |
| | | | | | | | |
| | | | | | | | |
| | | | | | | | |
| | | | | | | | |
| | | | | | | | |
| | | | | | | | |
| | | | | | | | |
| | | | | | | | |
| | | | | | | | |
| | | | | | | | |
| | | | | | | | |
| | | | | | | | |
| | | | | | | | |
| | | | | | | | |
| | | | | | | | |
| | | | | | | | |
| | | | | | | | |
| | | | | | | | |
| | | | | | | | |

HA

| MODEL : JWE-2400CUA-L-25B | | | | TITLE : JWE-2400CUA-R-25B ONLY | | | |
|----------------------------------|------------------------------|--------------------------|-------------|---------------------------------------|-----|--|--|
| INDEX NO. | DESCRIPTION | MATERIAL OR MODEL NUMBER | PART NUMBER | REQ'D NUMBER | | | |
| | | | | A-1 B-0 | B-1 | | |
| A-1 | SIDE PANEL (R-R) | S.S | 3Y5477A01 | 1 | 1 | | |
| A-2 | SIDE PANEL (L-R) | S.S | 3Y5476G01 | 1 | 1 | | |
| A-3 | REAR PANEL (R-R) | S.S | 3Y5478M01 | 1 | 1 | | |
| A-4 | REAR PANEL (L-R) | S.S | 3Y5479M01 | 1 | 1 | | |
| A-5 | TOP PANEL (R) | S.S | 1H4775G01 | 1 | 1 | | |
| A-19 | GUARD - RINSE (R) | S.S | 3Y5480M01 | 1 | 1 | | |
| B-1 | FLUSH TANK (R) | S.S | 1H4771G01 | 1 | 1 | | |
| B-14 | RINSE PIPE (LO) | S.S | 3Y2352G01 | 1 | 1 | | |
| B-15 | RINSE PIPE (UP) | S.S | 3Y2354G01 | 1 | 1 | | |
| B-39 | RACK RAIL (B-R) | S.S | 3Y4827G02 | 1 | 1 | | |
| B-40 | RACK RAIL (A-R) | S.S | 3Y4826G01 | 1 | 1 | | |
| B-81 | SWITCH PLATE (R) | S.S | 4Y6430G01 | 2 | 2 | | |
| C-1 | BOOSTER TANK (R) | S.S | 3Y5471G01 | 1 | 1 | | |
| C-2 | BASE - BOOSTER (R) | S.S | 3Y5474M01 | 1 | 1 | | |
| C-4 | SIDE PANEL (R) - BOOSTER (R) | S.S | 2X0310M01 | 1 | 1 | | |
| C-5 | SIDE PANEL (L) - BOOSTER (R) | S.S | 2X0311M01 | 1 | 1 | | |
| C-46 | BRACKET (B) - BOOSTER (R) | S.S | 3Y5475M01 | 1 | 1 | | |
| K-1 | WASH SPRAY ARM (UP-R) | S.S | 2H8382G01 | 1 | 1 | | |
| S-1 | WASH SPRAY ARM (LO-R) | S.S | 2H8383G01 | 1 | 1 | | |
| Z-5 | OPERATION BOX (A-R) | S.S | 3Y5481G01 | 1 | 1 | | |
| Z-6 | COVER - OPERATION BOX (A-R) | S.S | 4Y7044G01 | 1 | 1 | | |
| Z-11 | BOX - TABLE LIMIT SWITCH (R) | S.S | 3Y5484G01 | 1 | 1 | | |
| Z-14 | BRACKET (R) - MAGNET | S.S | 4Y4390G01 | 1 | 1 | | |
| | | | | | | | |
| | | | | | | | |
| | | | | | | | |
| | | | | | | | |
| | | | | | | | |
| | | | | | | | |
| | | | | | | | |
| | | | | | | | |
| | | | | | | | |
| | | | | | | | |
| | | | | | | | |
| | | | | | | | |
| | | | | | | | |