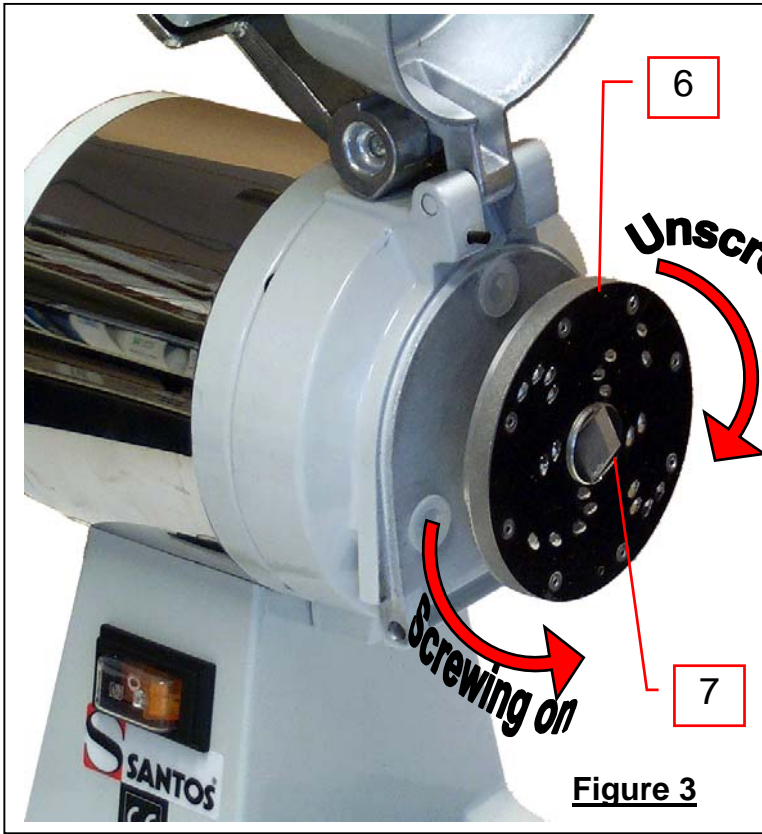

**Figure 1**



**Figure 2**



**Figure 3**

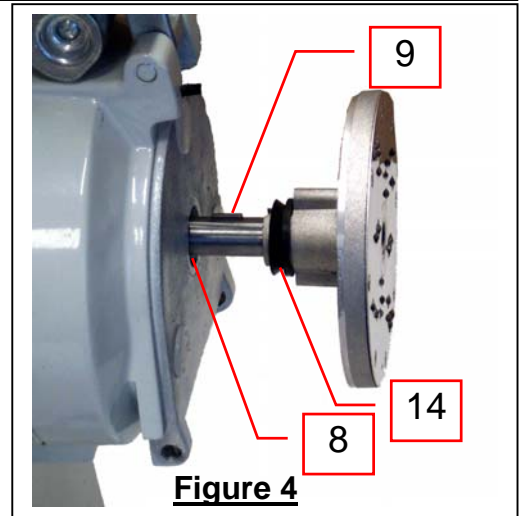

**Figure 4**

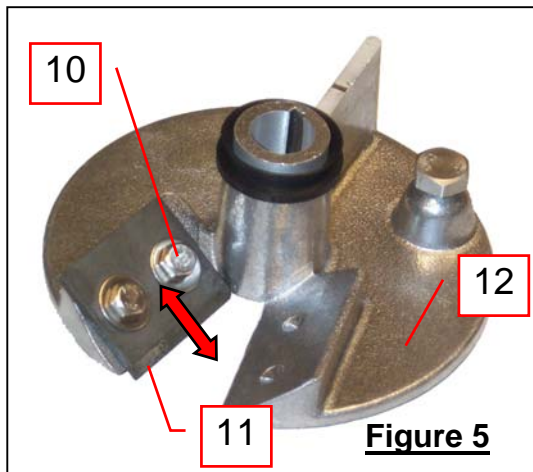

**Figure 5**

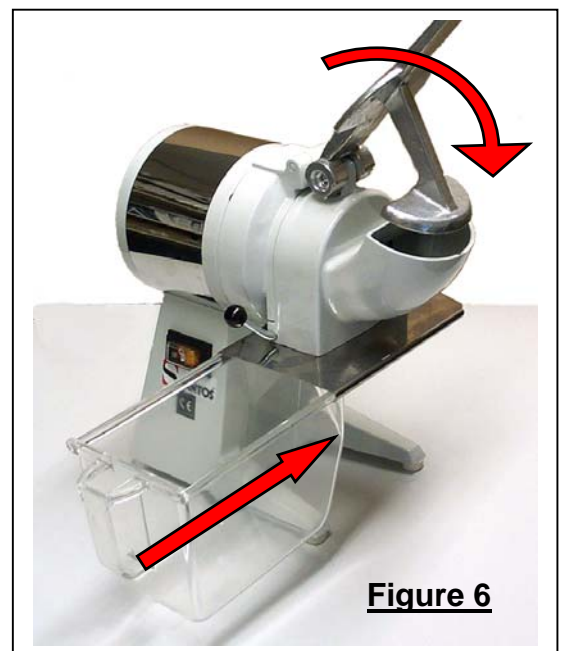

**Figure 6**



110-120V 50/60Hz wiring diagram

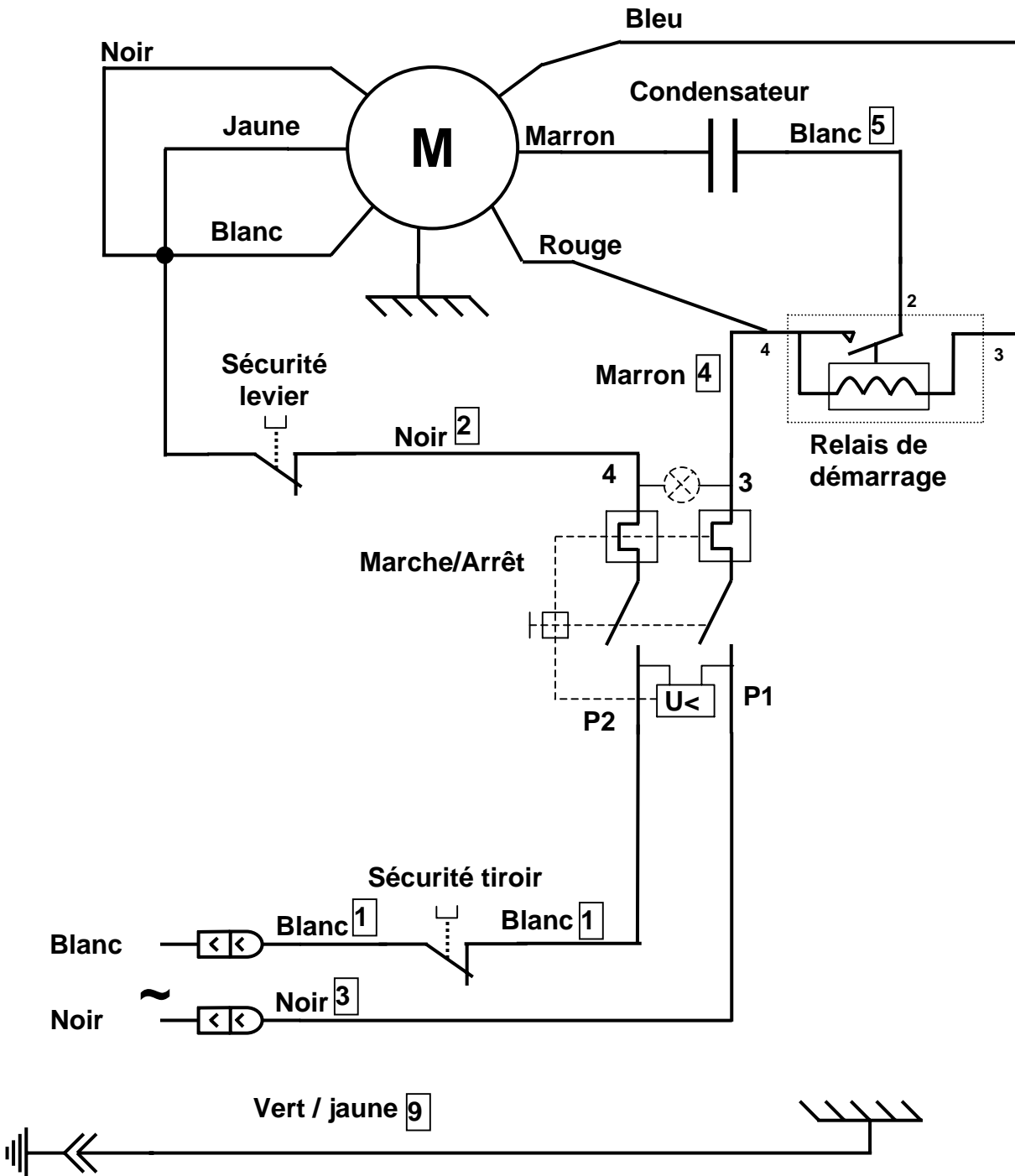

220-240V 60Hz wiring diagram

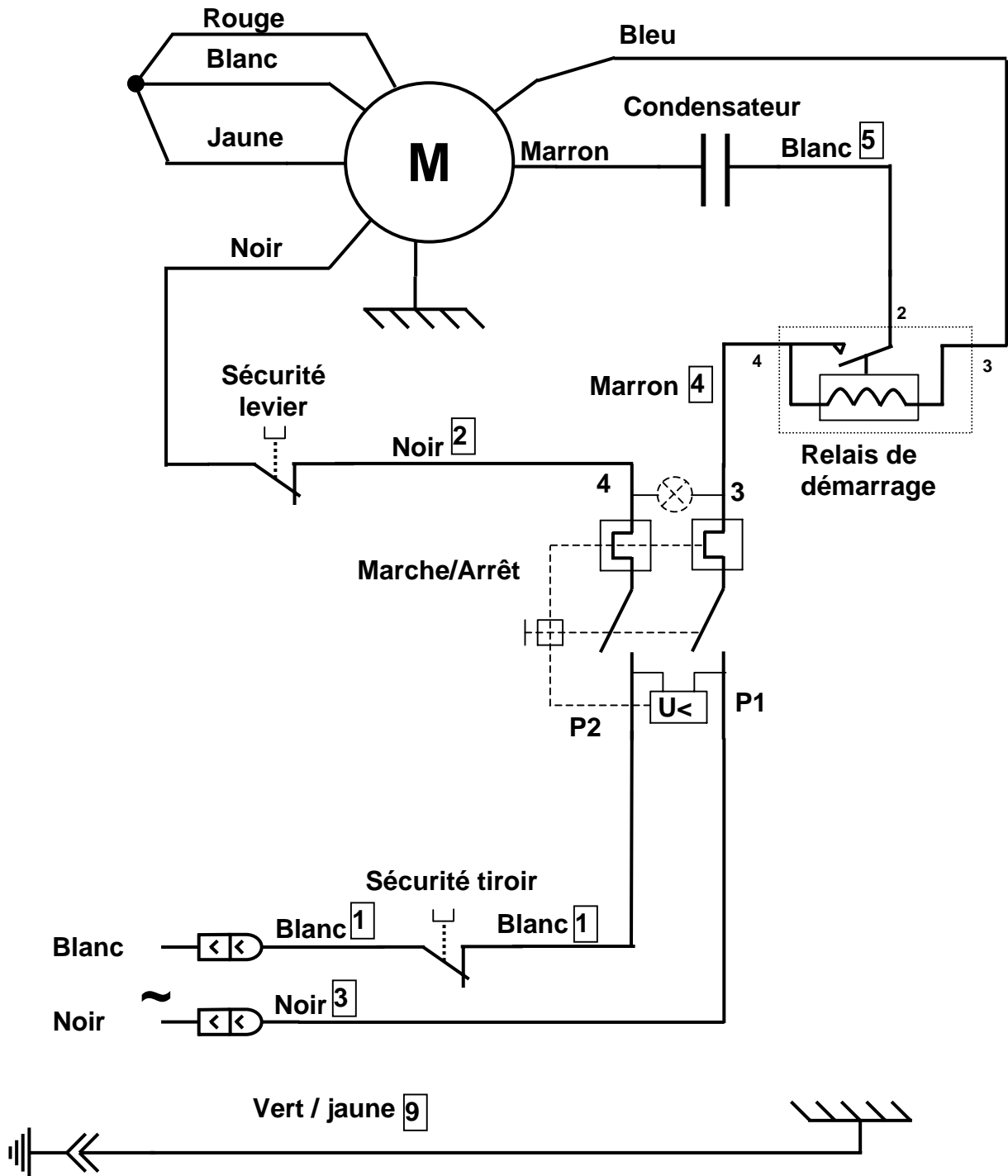

## TRANSLATION CHART FOR ELECTRICAL COMPONENTS

F	GB
Condensateur	Capacitor
Protecteur thermique	Thermals cut-out
Relais de démarrage	Starter relay
Marche/Arrêt	On/Off Switch
Micro-interrupteur	Micro-Switch

## TRANSLATION CHART FOR WIRE COLORS

F	GB
JAUNE	YELLOW
BLANC	WHITE
NOIR	BLACK
BLEU	BLUE
ROUGE	RED
MARRON	BROWN
ORANGE	ORANGE
VERT / JAUNE	GREEN / YELLOW

## TRANSLATION CHART FOR COMPONENTS

REP	Designation
1	Drawer to catch the food
2	Slideway to support drawer
3	Chute to insert the food
4	Lever
5	On-off switch
6	Complete disc
7	Locking screw for the disc
8	Spacer
9	Key
10	Fastening screw for the ice crusher knife
11	Ice crusher knife
12	Ice crusher knife support
13	Capacitor
14	Seal
15	Locking pin for the chute