

***KTM* POWERPARTS** **INFORMATION**

REMUS HEADER
REMUS SLIP-ON SILENCER



76505908000
76505999000

07.2015
3.213.418



KTM AG
5230 Mattighofen, Austria
www.ktm.com



3 DEUTSCH

Wir freuen uns, dass Sie sich für dieses Produkt entschieden haben.

Unser hochwertiges Qualitätsprodukt ist rennerprobt und wurde speziell für sportliche Herausforderungen entwickelt. Eine korrekte Montage des Produktes ist unerlässlich, um ein Maximum an Sicherheit und Funktionalität gewährleisten zu können. Bitte befolgen Sie daher die Montageanleitung oder wenden Sie sich an Ihren autorisierten Fachhändler.

Für falsche Montage oder Verwendung dieses Produktes kann der (Quasi-)Hersteller bzw. Lieferant nicht zur Verantwortung gezogen werden.
Vielen Dank.

7 ENGLISH

Thank you for choosing this product.

Our high quality product has been tested under racing conditions and was developed specifically for use in sports activities. Correct installation of the product is essential to ensure that a maximum degree of safety and functionality is achieved. Therefore, please follow the installation instructions or contact your authorized dealer.

The (quasi) manufacturer or supplier cannot be held responsible for products that are incorrectly mounted or inappropriately used.
Thank you.

11 ITALIANO

Grazie per aver scelto questo prodotto.

Questo nostro prodotto di pregiata qualità è collaudato nelle competizioni ed è stato sviluppato specificamente per gare sportive. Il montaggio corretto del prodotto è fondamentale per garantirne la massima sicurezza e funzionalità. Rispetti quindi le istruzioni di montaggio o rivolgerti al proprio concessionario autorizzato.

Il produttore (detentore del marchio)/fornitore non può essere considerato responsabile per un montaggio o impiego errato del presente prodotto.
Vi ringraziamo per l'attenzione!

15 FRANÇAIS

Merci d'avoir porté votre choix sur ce produit.

Notre produit de haute qualité est éprouvé pour les compétitions et a été conçu spécialement pour un usage sportif. Un montage approprié du produit est indispensable pour garantir une sécurité et une fonctionnalité maximales du véhicule. C'est pourquoi nous vous invitons à suivre scrupuleusement le manuel de montage ou à vous adresser à votre revendeur agréé.

En cas de montage ou d'utilisation non conformes de ce produit, le (quasi) constructeur ou le fournisseur déclinent toute responsabilité.
Merci !

19 ESPAÑOL

Le agradecemos que se haya decidido por este producto.

Este producto de alta calidad está probado para la competición y se ha desarrollado específicamente para las exigencias de este deporte. Para poder garantizar los máximos niveles de seguridad y funcionalidad, es imprescindible que el producto se monte correctamente. Por este motivo, es muy importante que siga las instrucciones del manual de montaje o que se ponga en contacto con su concesionario autorizado.

El (cuasi) fabricante y el proveedor de este producto no se harán responsables del montaje y el uso incorrectos.
¡Muchas gracias!

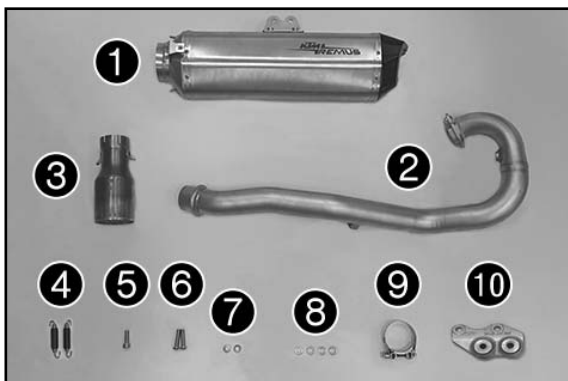

Lieferumfang

- 1x Enddämpfer ①
- 1x Krümmer ②
- 1x Kat ③
- 2x Feder ④
- 1x Schraube M8x30 ⑤
- 2x Schraube M8x35 ⑥
- 2x Federring M8 ⑦
- 4x Scheibe M8 ⑧
- 1x Schraubschelle ⑨
- 1x Halter ⑩
- 2x Blechmutter M8
- 1x Distanzscheibe

! VORSICHT

Diese Anlage darf nur in Kombination mit dem speziellen REMUS EFI-Mapping verbaut und betrieben werden. Das Mapping muss unbedingt vor dem erstmaligem Betrieb bei Deinem Vertragshändler installiert werden!



Warnung
Verbrennungsgefahr

Die Auspuffanlage wird beim Betrieb des Fahrzeugs sehr heiß.
- Auspuffanlage abkühlen lassen. Heiße Teile nicht berühren.

Vorarbeit

- Sitzbank abnehmen (s. Bedienungsanleitung).
- Seitenverkleidung abnehmen (s. Bedienungsanleitung).

Krümmer und Enddämpfer ausbauen

- Kabelbinder ⑪ entfernen.
- Steckerverbindung ⑫ der Lambdasonde freilegen und trennen.
- Kabel der Lambdasonde ausfädeln.
- Schrauben ⑬ entfernen.
- Auspuffhitzeschutzblech entfernen.

- Muttern ⑭ des Krümmers entfernen.

HINWEIS

Distanzbuchse nicht verlieren.

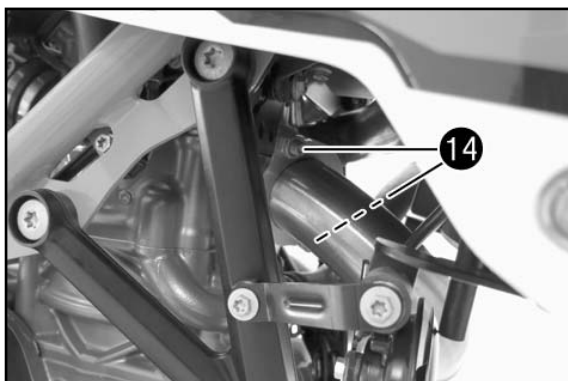
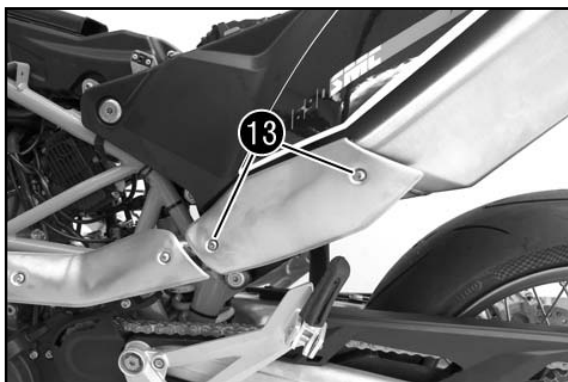
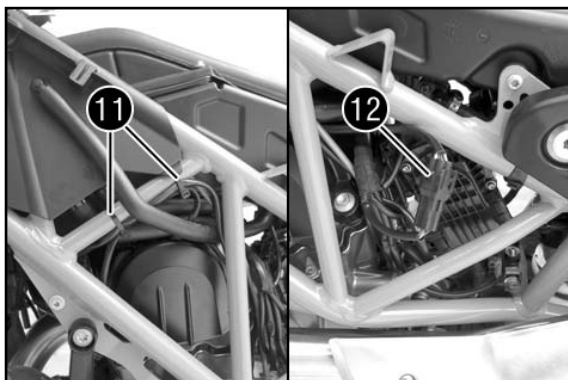

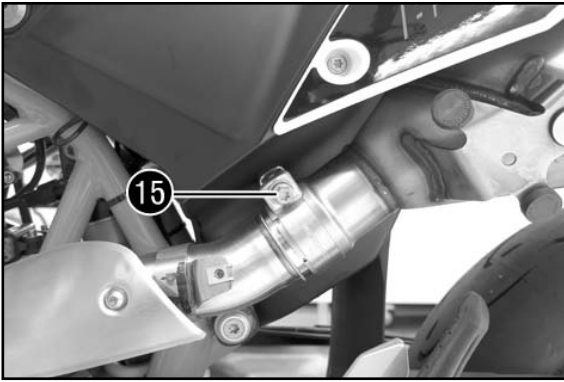

- Schraubenschelle 15 lösen.

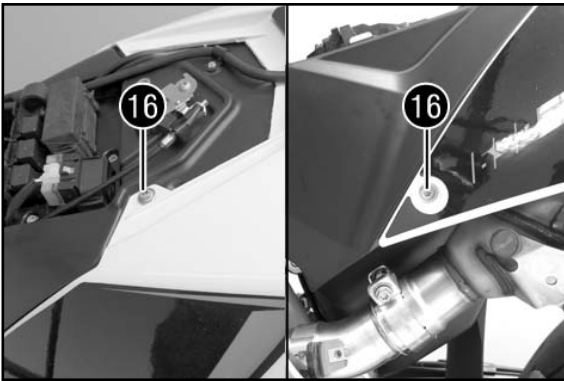

- Schrauben 16 entfernen.
- Heckverkleidung anheben.

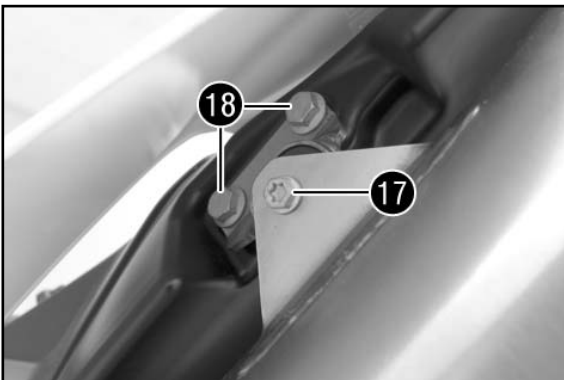

- Schraube 17 entfernen.
- Enddämpfer abnehmen.
- Schrauben 18 entfernen.
- Halter abnehmen.

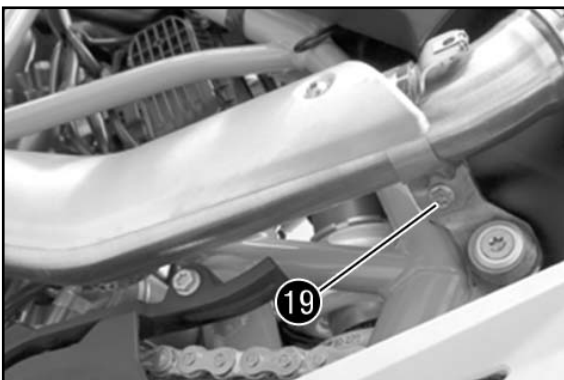

- Schraube 19 entfernen.
- Krümmer mit Auspuffhitzeschutzblech abnehmen.

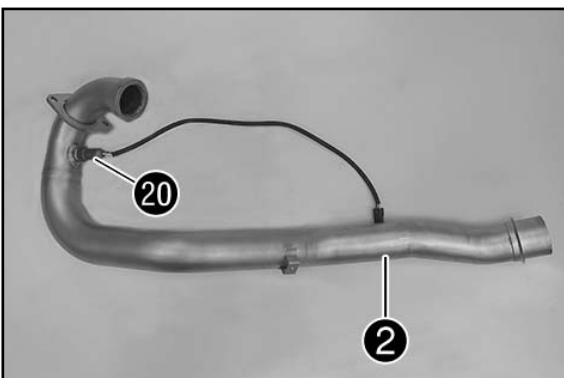

Montage

- Lambdasonde 20 vom Original-Krümmer entfernen.
- Lambdasonde 20 am Krümmer 2 (Lieferumfang) montieren und mit 25 Nm (Kupferpaste) festziehen.

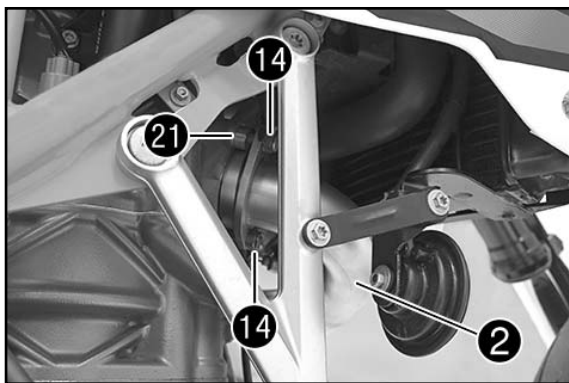

- Krümmer ② positionieren.
- Distanzbuchse ②① positionieren.
- Muttern ①④ montieren und mit 25 Nm (Kupferpaste) festziehen.

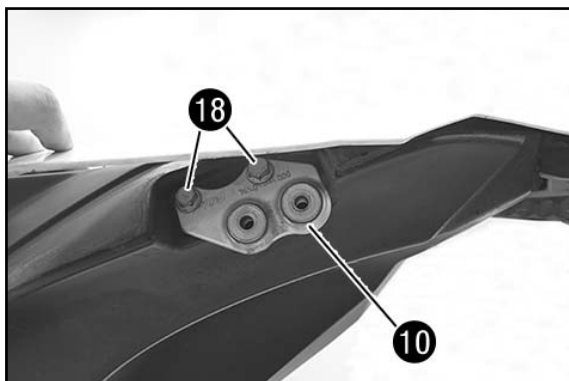

- Halter ⑩ (Lieferumfang) positionieren.
- Schrauben ①⑧ montieren und mit 25 Nm festziehen.

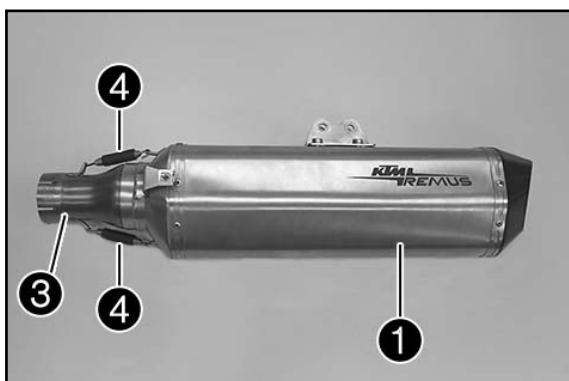

- Kat ③ (Lieferumfang) am Enddämpfer ① (Lieferumfang) montieren.
- Federn ④ (Lieferumfang) montieren.

Federhaken 503.05.017.000

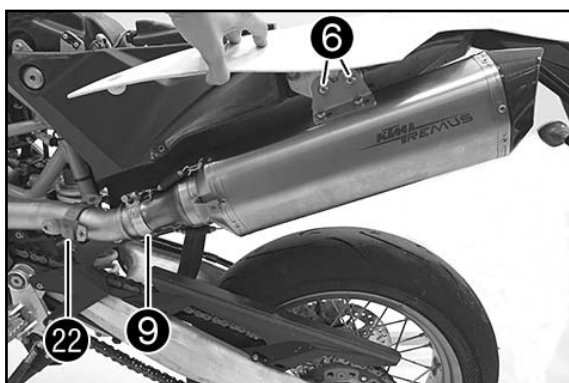

- Schraubschelle ⑨ (Lieferumfang) montieren, aber noch nicht festziehen.
- Enddämpfer montieren.
- Schrauben ⑥ mit Federringen ⑦ und Scheiben ⑧ (alles Lieferumfang) montieren und mit 25 Nm festziehen.

HINWEIS

Anschließend die 4 Schrauben des vormontierten Halters am Enddämpfer ebenfalls mit 25 Nm festziehen.

- Schraubschelle ⑨ positionieren und mit 12 Nm (Kupferpaste) festziehen.

- Original-Halteschelle ②② am Krümmer montieren.

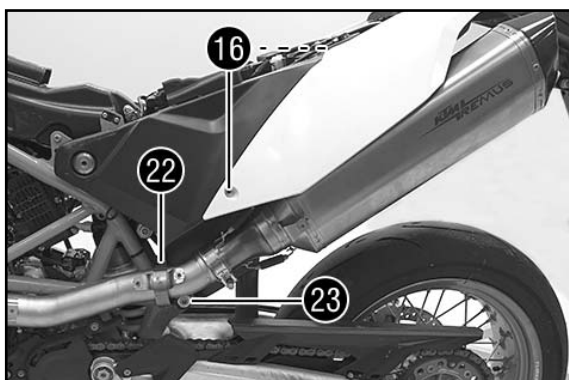

- Heckverkleidung positionieren.
- Schrauben ①⑥ montieren und mit 5 Nm festziehen.
- Halteschelle ②② mit Schraube ⑤, Scheibe ⑥ und Distanzscheibe (alles Lieferumfang) montieren und mit 12 Nm (Kupferpaste) festziehen.

HINWEIS

Zur leichteren Montage der Halteschelle, Schraube ②③ entfernen.

Anzugsdrehmoment Schraube Kraftstofftank unten:
25 Nm (Loctite 243)

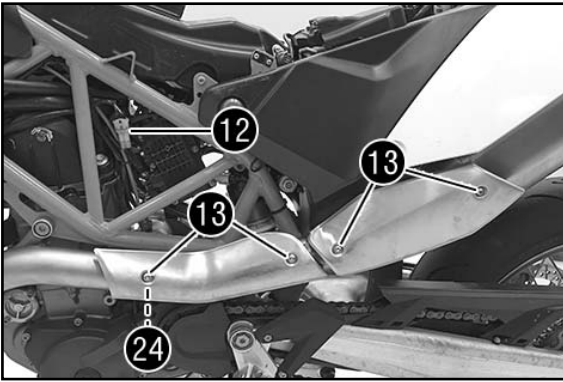

- Original-Auspuffhitzeschutzbleche positionieren.
- Schrauben 13 montieren und mit 8 Nm (Loctite 243) festziehen.

HINWEIS

Blechmutter 24 vom Lieferumfang verwenden.

- Steckerverbindung 12 der Lambdasonde zusammenstecken. Kabel spannungsfrei verlegen und mit Kabelbinder sichern.



Nacharbeit

- Seitenverkleidung montieren (s. Bedienungsanleitung).
- Sitzbank montieren (s. Bedienungsanleitung).

! VORSICHT

Beim erstmaligen Betrieb des Enddämpfers ist die Motordrehzahl für ca. 5 Minuten niedrig zu halten, um den Enddämpfer gleichmäßig zu erwärmen. Nur so kann der Dämmstoff seinen vollen Wirkungsgrad erreichen und die geforderte Lautstärke einhalten!

Endmontage

Stellen Sie sicher, dass der Schalldämpfer keine anderen Teile des Motorrades berührt. Fettrückstände mit einem weichen Tuch, besprüht mit Mehrzweckschmiermittel entfernen. Das Reinigen verhindert, dass sich Flecken auf der Oberfläche einbrennen. Verwenden Sie keine aggressiven chemischen Reiniger.

Prüfen Sie die Funktion der Bremsen und der Aufhängung. Stellen Sie sicher, dass alle Schrauben angezogen sind. Falls die Auspuffanlage die Verkleidung oder andere Teile berührt, wiederholen Sie die Justierung oder kontaktieren Sie Ihren Vertrags-händler!

Es ist normal, wenn beim ersten Betrieb der Auspuffanlage weißer Rauch aus dem Schalldämpfer kommt! Abschließend gesamte Auspuffanlage auf Dichtheit prüfen. Stehen Sie beim ersten Betrieb nicht hinter dem Auspuff!

Wartung der Auspuffanlage

Reinigung mit einem Mehrzweckschmiermittelspray. Ein Wechsel der Farbe der Auspuffanlage ist aufgrund der hohen Temperatur normal. Die Abnutzung des Dämmmaterials des Schalldämpfers hängt von der Art des Motors und des Fahrstils ab. Setzen Sie sich mit Ihrem Händler in Verbindung, wenn sichtbare Änderungen auf der Außenhülle des Schalldämpfers auftreten oder der Geräuschpegel erhöht ist. Überprüfen Sie periodisch, dass alle Schrauben genügend angezogen sind und die Federn korrekt sitzen.



Scope of supply

- 1x main silencer ①
- 1x manifold ②
- 1x cat ③
- 2x springs ④
- 1x screw M8x30 ⑤
- 2x screws M8x35 ⑥
- 2x spring rings M8 ⑦
- 4x washers M8 ⑧
- 1x screw clamp ⑨
- 1x holder ⑩
- 2x speed nut M8
- 1x spacer washer

! ATTENTION

This unit may only be installed and operated in combination with the special REMUS EFI mapping. The mapping must be installed by your authorized dealer before initial operation.



Warning
Danger of burns

The exhaust system becomes very hot during operation.
- Let the exhaust system cool down. Do not touch hot parts.

Preparatory work

- Take off the seat (see the Owner's Manual).
- Take off the side cover (see the Owner's Manual).

Remove manifold and main silencer

- Remove cable tie ⑪ .
- Expose and disconnect plug-in connector ⑫ of the lambda sensor.
- Feed out the cable of the lambda sensor.
- Remove screws ⑬ .
- Remove the exhaust heat shield.

- Remove nuts ⑭ of the manifold.

NOTE

Do not misplace the spacer.

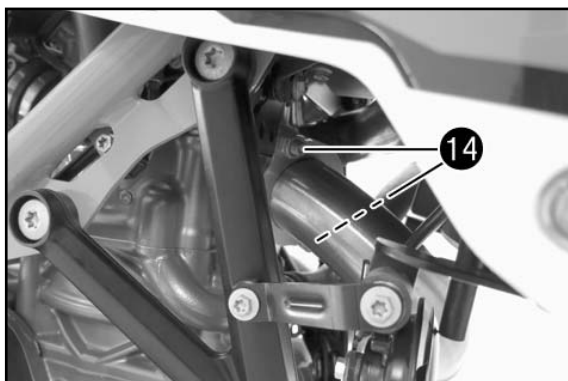
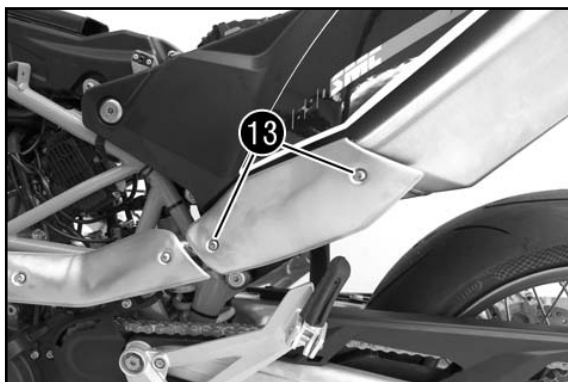
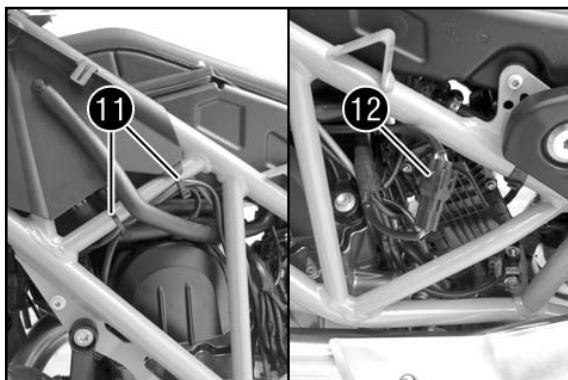

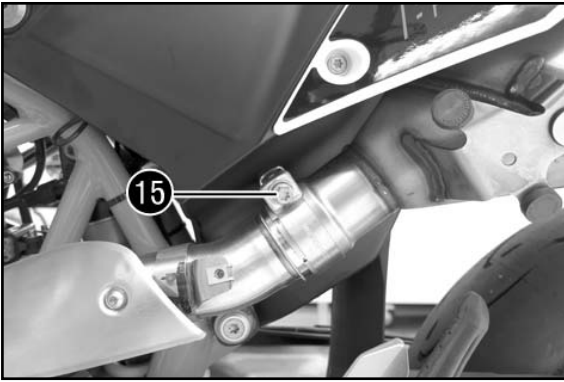

- Release screw clamp 15 .

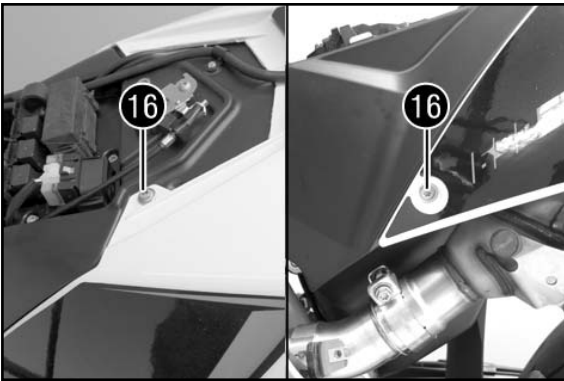

- Remove screws 16 .
- Lift the rear fairing.

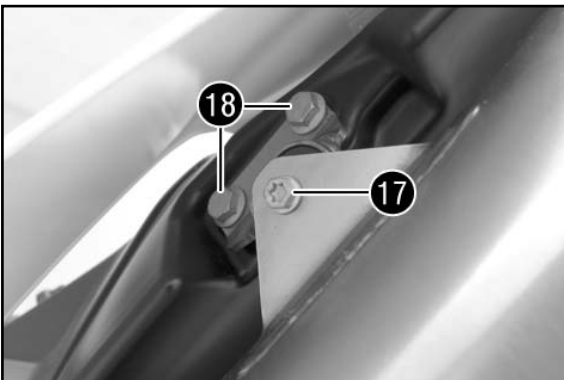

- Remove screw 17 .
- Take off the main silencer.
- Remove screws 18 .
- Remove the holder.

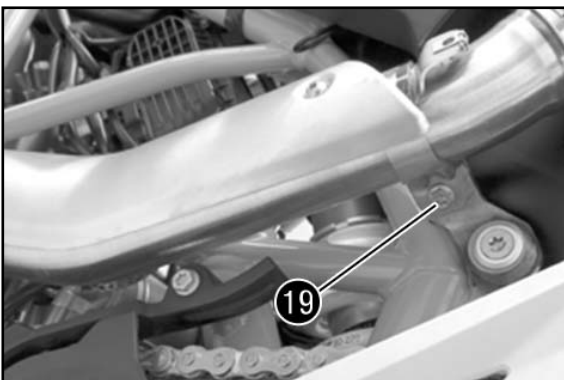

- Remove screw 19 .
- Take off the manifold with the exhaust heat shield.

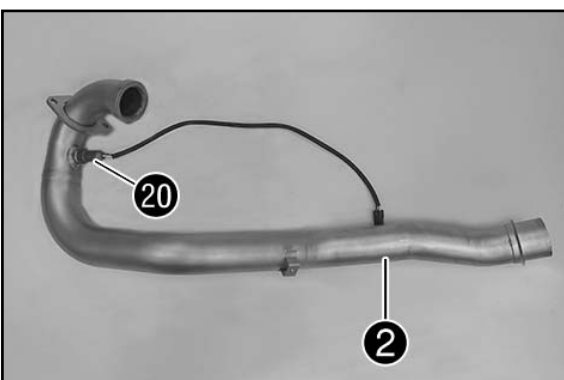

Assembly

- Remove lambda sensor 20 from original manifold.
- Mount lambda sensor 20 on manifold 2 (included) and tighten to 25 Nm (copper paste).

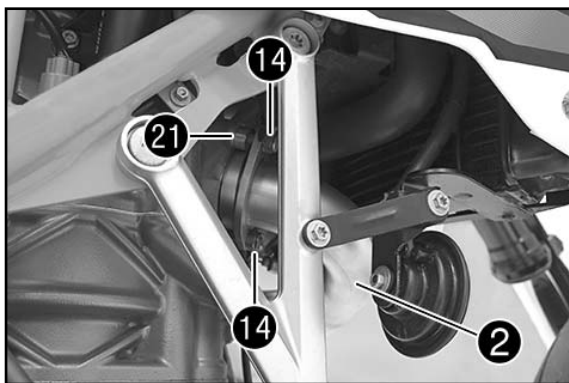

- Position manifold ②.
- Position spacer ②①.
- Mount nuts ①④ and tighten to 25 Nm (copper paste).

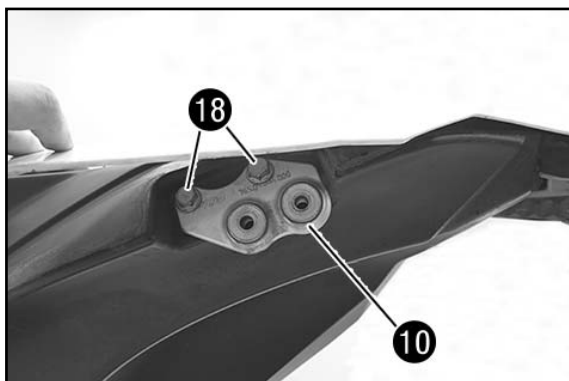

- Position holder ①⑩ (included).
- Mount screws ①⑧ and tighten to 25 Nm.

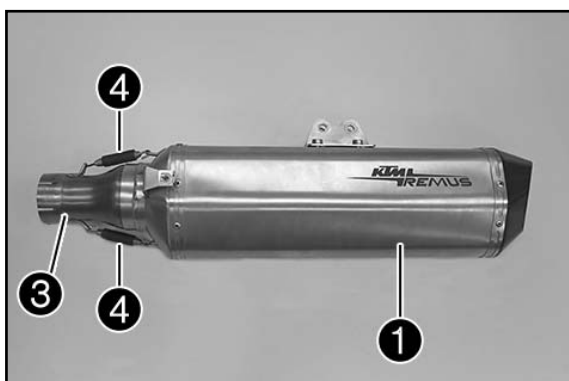

- Mount cat ③ (included) on main silencer ① (included).
- Mount springs ④ (included).

Spring hook 503.05.017.000

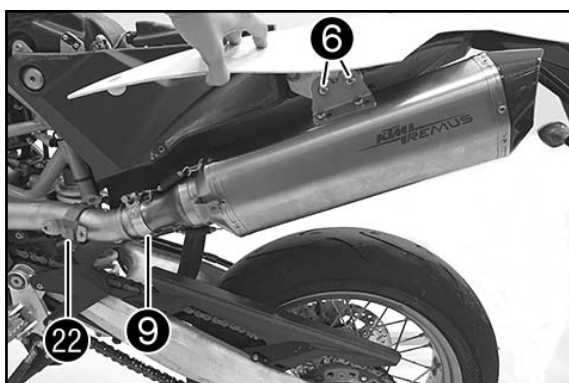

- Mount screw clamp ⑨ (included) but do not tighten yet.
- Mount the main silencer.
- Mount screws ⑥ with spring rings ⑦ and washers ⑧ (included) and tighten to 25 Nm.

NOTE

Then tighten the 4 screws on the preassembled holder on the main silencer to 25 Nm.

- Position screw clamp ⑨ and tighten to 12 Nm (copper paste).

- Mount original retaining clamp ②② on the manifold.

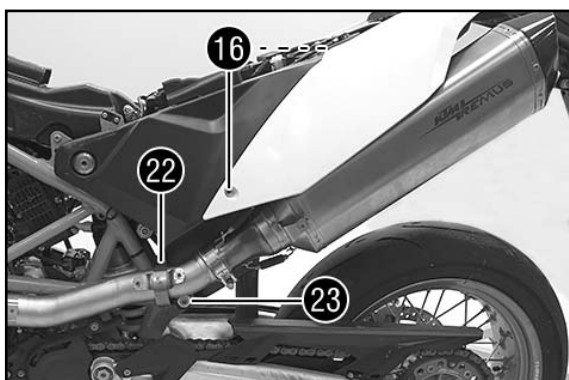

- Position the rear fairing.
- Mount screws ①⑥ and tighten to 5 Nm.
- Mount retaining clamp ②② with screw ⑤, washer ⑧ and spacer washer (all included) and tighten to 12 Nm (copper paste).

NOTE

To make it easier to mount the retaining clamp, remove screw ②③.

Tightening torque of screw, fuel tank, bottom:
25 Nm (Loctite 243)

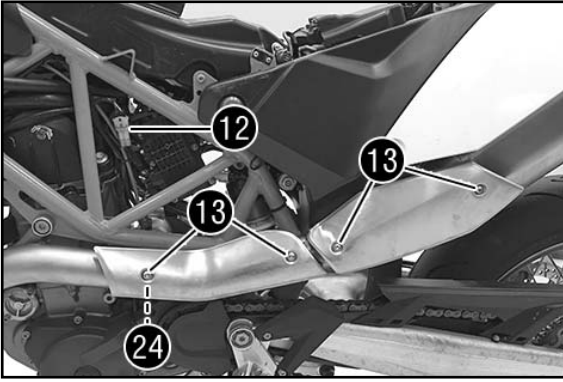

- Position the original exhaust heat shield.
- Mount screws 13 and tighten to 8 Nm (Loctite 243).

NOTE

Use speed nut 24 from scope of supply.

- Connect plug-in connector 12 of the lambda sensor. Route the cable without tension and secure with cable tie.



Final steps

- Mount the side cover (see Owner's Manual).
- Mount the seat (see the Owner's Manual).

! ATTENTION

When you first use the main silencer, keep the engine speed low for about 5 minutes to warm the main silencer evenly. This is the only way to ensure that the rock wool will have full effect and keep noise down to the required level!

Final steps

Make sure that the silencer is not touching any other parts of the motorcycle. Remove all grease residue with a soft cloth sprayed with multi-purpose lubricant. Cleaning prevents stains from baking onto the surface. Do not use aggressive chemical cleaners.

Test the function of the brakes and suspension. Make sure that all screws are tightened. If the exhaust system is touching the trim or other parts, readjust the unit or contact your authorized dealer.

When the exhaust system is first put into operation, it is normal for white smoke to be emitted by the silencer. Finally, check for leaks in the whole exhaust system. Do not stand behind the exhaust when it is being used for the first time.

Maintaining the exhaust system

Clean using a multi-purpose lubricant spray. A change in color of the exhaust system is normal due to the high temperatures. Wear and tear to the sound insulation material of the silencer depends on the type of engine and driving style. Contact your dealer in the event of visible changes to the outer sleeve of the silencer or if the noise level is raised. Check periodically that all screws are tightened sufficiently and that the springs are seated correctly.

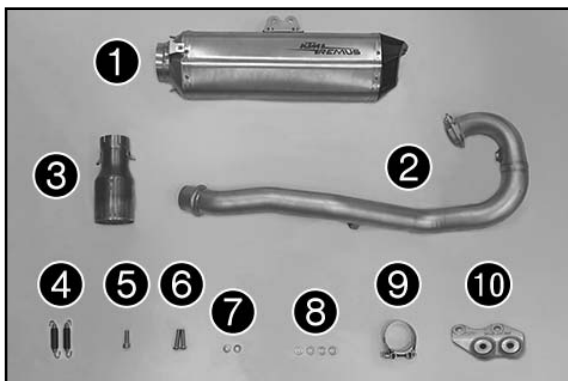

Materiale fornito

- N. 1 silenziatore ①
- N. 1 collettore ②
- N. 1 catalizzatore ③
- N. 2 molle ④
- N. 1 vite M8x30 ⑤
- N. 2 viti M8x35 ⑥
- N. 2 anelli elastici M8 ⑦
- N. 4 rondelle M8 ⑧
- N. 1 fascetta a vite ⑨
- N. 1 supporto ⑩
- N. 2 dadi per lamiera M8
- N. 1 rondella distanziale

! AVVERTIMENTO

Questo impianto può essere utilizzato e montato soltanto in abbinamento alla speciale mappatura EFI REMUS. La mappatura deve essere tassativamente installata dal proprio rivenditore prima del primo utilizzo!



Avvertenza

Pericolo di ustione

Durante il funzionamento, l'impianto di scarico del veicolo raggiunge temperature molto alte.

- Far raffreddare l'impianto di scarico. Non toccare i componenti che scottano.

Operazione preliminare

- Rimuovere la sella (v. il manuale d'uso).
- Rimuovere la fiancatina (v. il manuale d'uso).

Smontaggio del collettore e del silenziatore

- Rimuovere la fascetta serracavi ⑪.
- Scoprire e scollegare il connettore ⑫ della sonda lambda.
- Sfilare il cavo della sonda lambda.

- Rimuovere le viti ⑬.
- Rimuovere la lamiera termoisolante dello scarico.

- Rimuovere i dadi ⑭ del collettore.

NOTA

Prestare attenzione a non perdere la bussola distanziale.

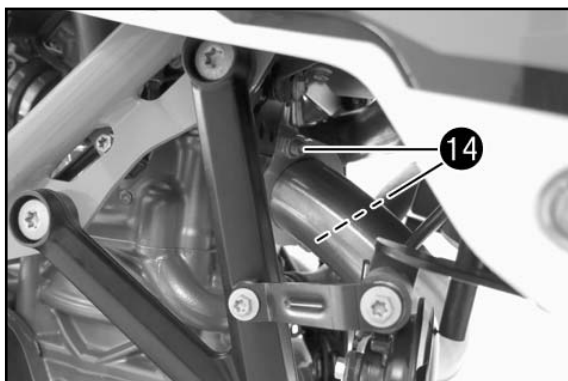
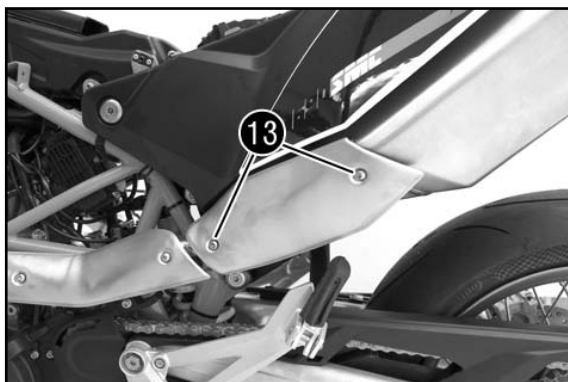
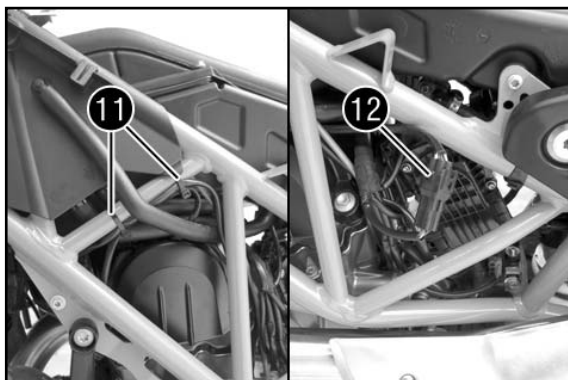

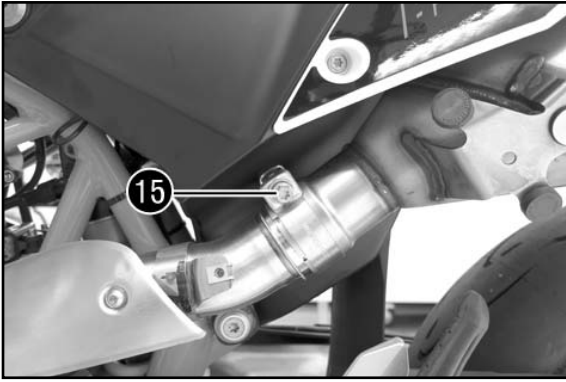

- Allentare la fascetta a vite 15.

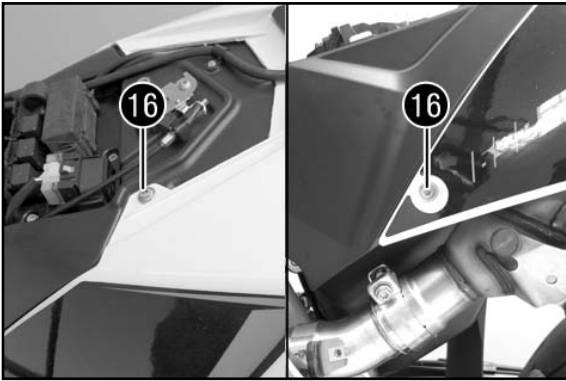

- Rimuovere le viti 16.
- Sollevare la carena posteriore.

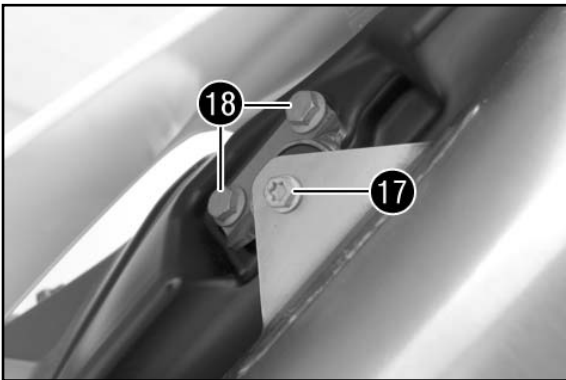

- Rimuovere la vite 17.
- Rimuovere il silenziatore.
- Rimuovere le viti 18.
- Rimuovere il supporto.

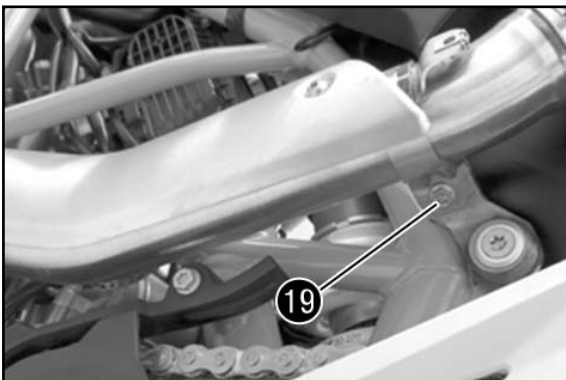

- Rimuovere la vite 19.
- Rimuovere il collettore con la lamiera termoisolante dello scarico.

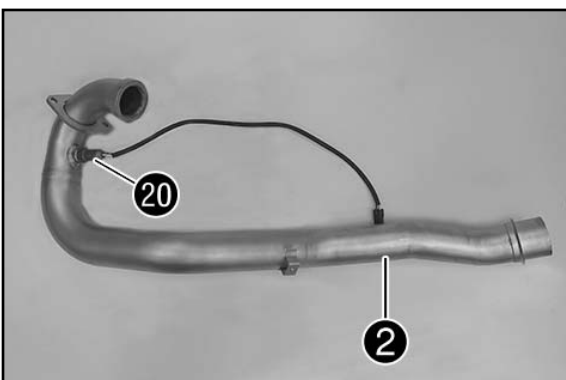

Montaggio

- Rimuovere la sonda lambda 20 dal collettore originale.
- Montare la sonda lambda 20 sul collettore 2 (in dotazione) e serrare a 25 Nm (pasta al rame).

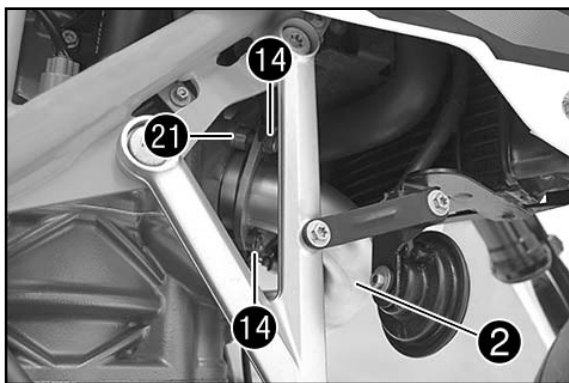

- Posizionare il collettore ②.
- Posizionare la bussola distanziale ②①.
- Montare i dadi ①④ e serrarli a 25 Nm (pasta al rame).

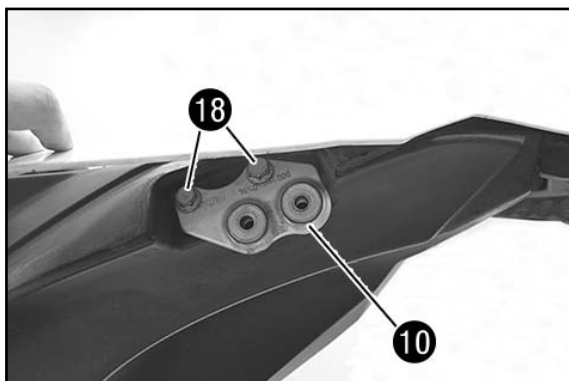

- Posizionare il supporto ①⑩ (in dotazione).
- Montare le viti ①⑧ e serrarle a 25 Nm.

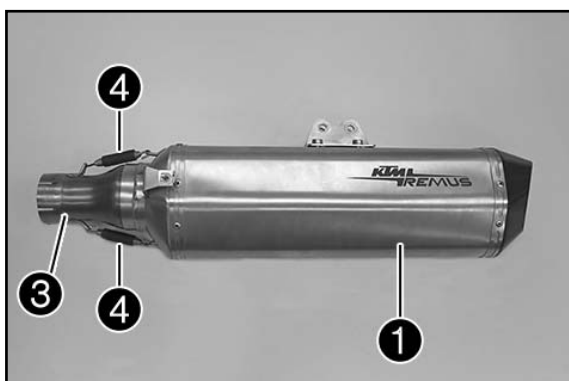

- Montare il catalizzatore ③ (in dotazione) sul silenziatore ① (in dotazione).
- Montare le molle ④ (in dotazione).

Tira molle 503.05.017.000

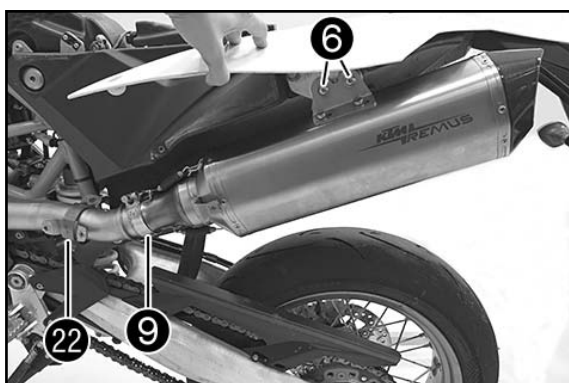

- Montare la fascetta a vite ⑥ (in dotazione), ma non serrarla ancora.
- Montare il silenziatore.
- Montare le viti ⑥ con gli anelli elastici ⑦ e le rondelle ⑧ (tutto in dotazione) e serrare a 25 Nm.

NOTA

Serrare quindi anche le 4 viti del supporto premontato sul silenziatore a 25 Nm.

- Posizionare la fascetta a vite ⑥ e serrare a 12 Nm (pasta al rame).
- Montare la fascetta di ritegno originale ②② sul collettore.

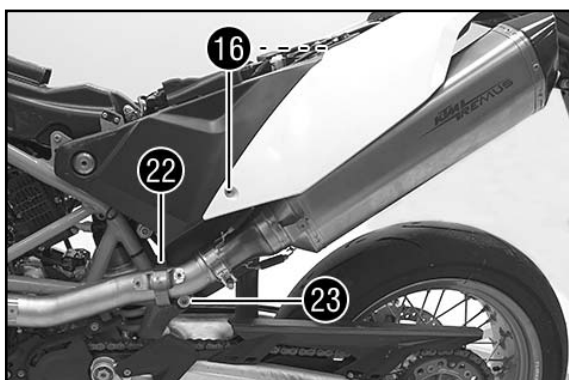

- Posizionare la carena posteriore.
- Montare le viti ①⑥ e serrarle a 5 Nm.
- Montare la fascetta di ritegno ②② con la vite ⑤, la rondella ③ e la rondella distanziale (tutto in dotazione) e serrare a 12 Nm (pasta al rame).

NOTA

Per montare più agevolmente la fascetta di ritegno, rimuovere la vite ②③.

Coppia di serraggio vite serbatoio carburante inferiore:
25 Nm (Loctite 243)

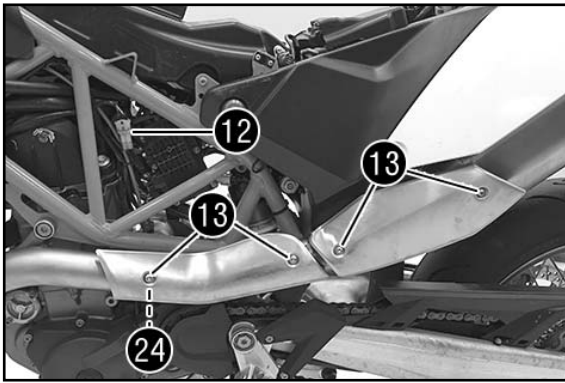

- Posizionare le lamiere termoisolanti dello scarico originali.
- Montare le viti 13 e serrarle a 8 Nm (Loctite 243).

NOTA

Utilizzare il dado per lamiera 24 in dotazione.

- Collegare il connettore 12 della sonda lambda. Posizionare il cavo in modo che non sia in tensione e assicurarlo con una fascetta serracavi.



Operazione conclusiva

- Montare la fiancatina (v. manuale d'uso).
- Montare la sella (v. il manuale d'uso).

! AVVERTIMENTO

Durante la prima messa in funzione del silenziatore, mantenere basso il regime del motore per circa 5 minuti, al fine di far riscaldare in modo uniforme il silenziatore. Solo così il materiale isolante può raggiungere la massima efficienza e contenere la rumorosità ai valori desiderati!

Montaggio finale

Assicurarsi che il silenziatore non tocchi altri componenti della motocicletta. Rimuovere eventuali residui di grasso con un panno morbido su cui sia stato spruzzato un lubrificante multiuso. La pulizia impedisce alle macchie di rimanere impresse sulla superficie. Non utilizzare prodotti chimici aggressivi.

Verificare il corretto funzionamento dei freni e della sospensione. Assicurarsi che tutte le viti siano ben serrate. Se l'impianto di scarico tocca il rivestimento o altri componenti, ripetere la regolazione oppure contattare il proprio rivenditore!

È normale che, durante il primo funzionamento dell'impianto di scarico, fuoriesca fumo bianco dal silenziatore! Al termine controllare la tenuta dell'intero impianto di scarico. Al momento della prima accensione, non sostare dietro lo scarico!

Manutenzione dell'impianto di scarico

Pulire con uno spray lubrificante multiuso.

A causa dell'alta temperatura, è normale che l'impianto di scarico cambi colore.

Il grado di usura del materiale isolante del silenziatore dipende dal tipo di motore e dallo stile di guida. Contattare il proprio concessionario nel caso in cui si notino modifiche visibili sul rivestimento esterno del silenziatore o se il livello di rumorosità dovesse risultare troppo alto. Controllare periodicamente che tutte le viti siano ben avvitate e che le molle siano correttamente in sede.



Contenu de la livraison

- 1x silencieux arrière ①
- 1x collecteur ②
- 1x Kat ③
- 2x ressorts ④
- 1x vis M8x30 ⑤
- 2x vis M8x35 ⑥
- 2x bagues de réglage M8 ⑦
- 4x rondelles M8 ⑧
- 1x collier de serrage ⑨
- 1x support ⑩
- 2x écrous en tôle M8
- 1x rondelle d'écartement

! ATTENTION

Le système ne peut être monté et utilisé qu'en liaison avec le Mapping EFI Remus spécial. Le Mapping doit impérativement être installé chez le concessionnaire avant la première utilisation !



Avertissement

Risque de brûlures

Pendant le fonctionnement du véhicule, l'échappement devient très chaud.

- Laisser l'échappement refroidir. Ne pas toucher les pièces brûlantes.

Travaux préalables

- Déposer la selle (voir le manuel d'utilisation).
- Retirer l'habillage latéral (voir manuel d'utilisation).

Déposer le collecteur et le silencieux arrière

- Retirer le serre-câble ⑪.
- Dégager le connecteur ⑫ de la sonde lambda et le débrancher.
- Débrancher le câble de la sonde lambda.

- Retirer les vis ⑬.
- Retirer la tôle de la plaque de protection thermique d'échappement.

- Retirer les écrous ⑭ du collecteur.

REMARQUE

Ne pas perdre la douille-entretoise.

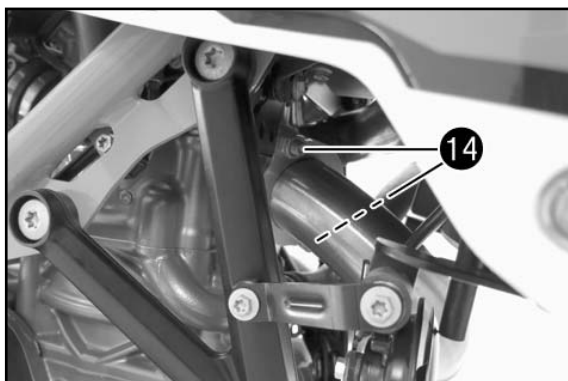
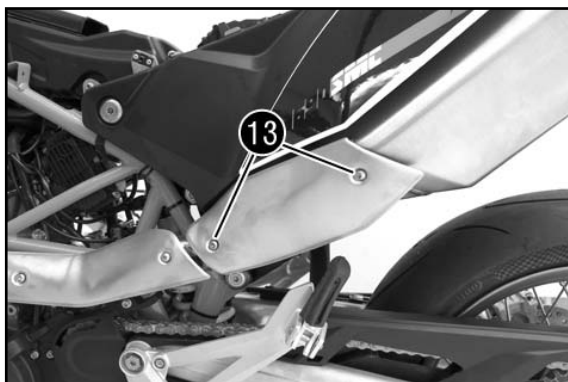
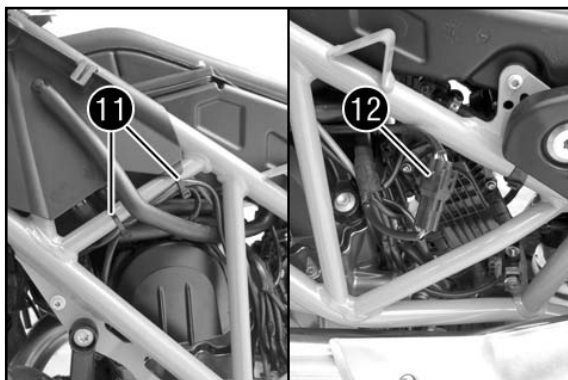

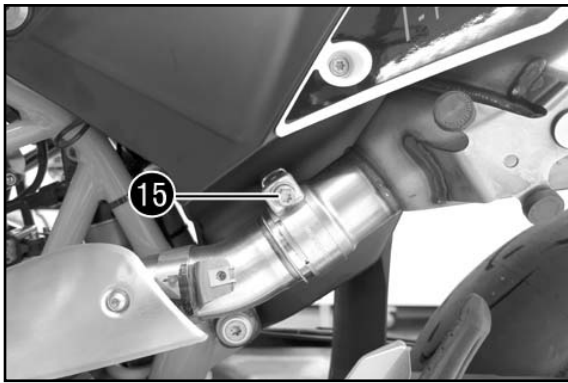

- Desserrer **15** le collier de serrage.

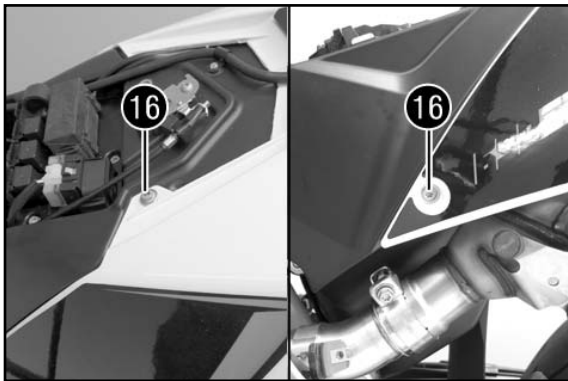

- Retirer les vis **16**.
- Soulever l'habillage arrière.

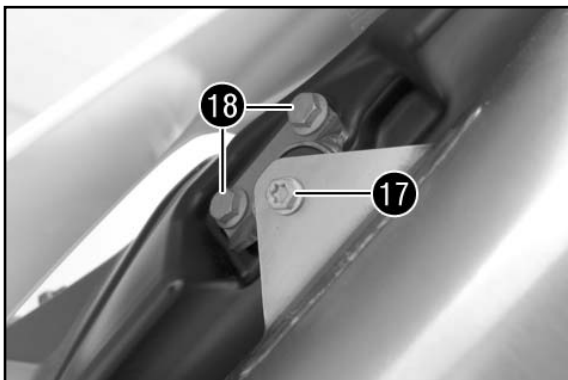

- Retirer la vis **17**.
- Déposer le silencieux arrière.
- Retirer les vis **18**.
- Retirer le support.

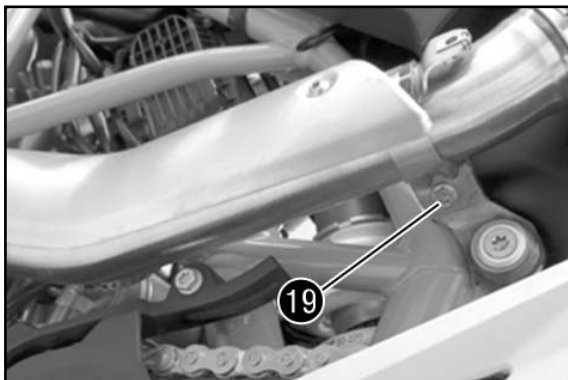

- Retirer la vis **19**.
- Retirer le collecteur avec la plaque de protection thermique d'échappement.

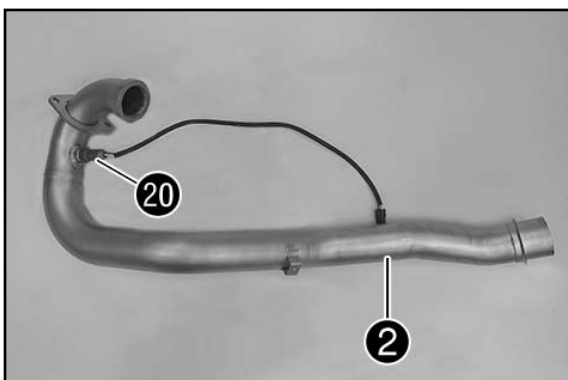

Montage

- Retirer la sonde lambda **20** du collecteur d'origine.
- Mettre en place la sonde lambda **20** sur le collecteur **2** (fourni) et serrer à 25 Nm (pâte de cuivre).

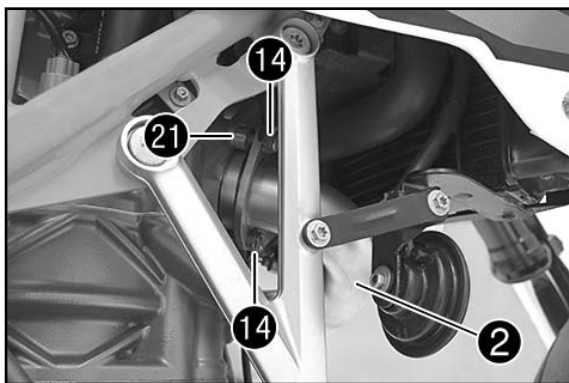

- Placer le collecteur ②.
- Placer ②① la douille d'entretoise.
- Mettre en place les écrous ⑭ et serrer à 25 Nm (pâte de cuivre).

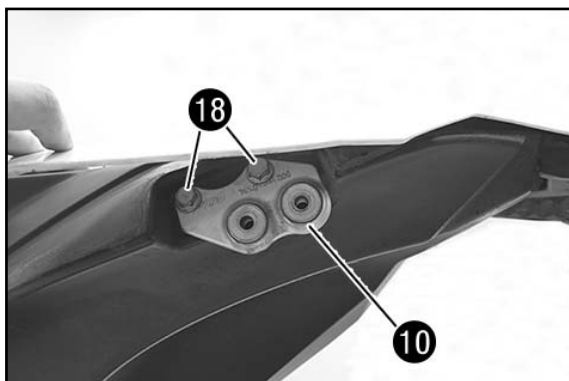

- Placer le support ⑩ (fourni).
- Mettre en place les vis ⑱ et serrer à 25 Nm.



- Mettre en place le Kat ③ (fourni) sur le silencieux arrière ① (fourni).
- Mettre en place les ressorts ④ (fournis).

Crochets à ressort 503.05.017.000

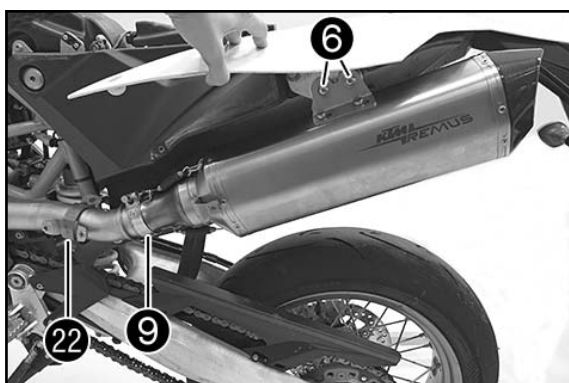

- Mettre en place le collier de serrage ⑨ (fourni) sans le serrer.
- Monter le silencieux arrière.
- Mettre en place les vis ⑥ avec bagues de réglage ⑦ et rondelles ⑧ (toutes ces pièces sont fournies) et serrer à 25 Nm.

REMARQUE

Serrer également ensuite les 4 vis du support prémonté sur le silencieux arrière à 25 Nm.

- Mettre en place le collier de serrage ⑨ et serrer à 12 Nm (pâte de cuivre).

- Mettre en place le collier de maintien d'origine ⑳ sur le collecteur.

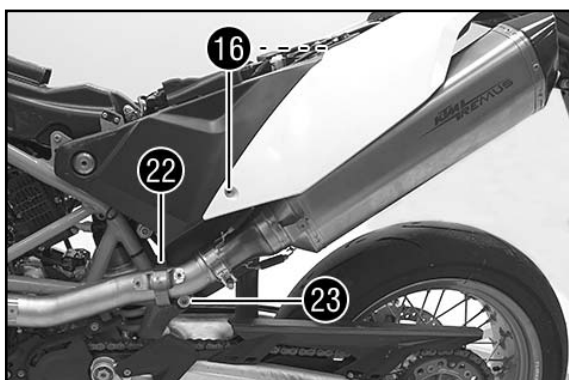

- Placer l'habillage arrière.
- Mettre en place les vis ⑰ et serrer à 5 Nm.
- Mettre en place le collier de maintien ㉒ avec vis ⑤ et rondelle d'écartement ③ (tous fournis) et serrer à 12 Nm (pâte de cuivre).

REMARQUE

Pour faciliter le montage du collier de maintien, retirer la vis ㉓.

Couple de serrage des vis du bas du réservoir de carburant : 25 Nm (Loctite 243)

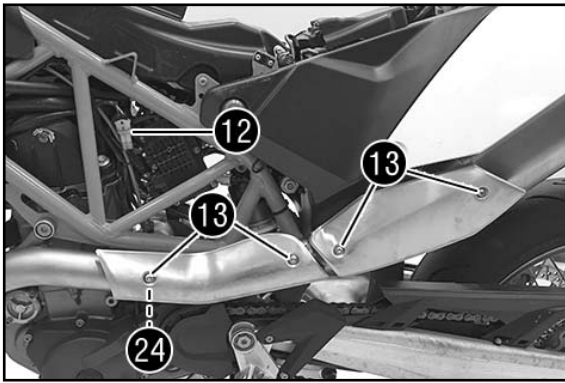

- Placer les plaques de protection thermique d'échappement d'origine.
- Mettre en place les vis 13 et serrer à 8 Nm (Loctite 243).

REMARQUE

Utiliser l'écrou en tôle 24 fourni.

- Brancher le connecteur 12 de la sonde lambda. Poser le câble de manière à ce qu'il ne soit soumis à aucune contrainte et le fixer à l'aide d'un serre-câble.



Travaux ultérieurs

- Mettre en place l'habillage latéral (voir manuel d'utilisation).
- Poser la selle (voir le manuel d'utilisation).

! ATTENTION

Lors de la première utilisation du silencieux arrière, laisser tourner le moteur au ralenti pendant 5 minutes environ pour réchauffer le silencieux arrière uniformément. Cette précaution est nécessaire pour que la laine de roche atteigne son degré d'efficacité maximal et que les niveaux d'émission sonore prescrits soient respectés!

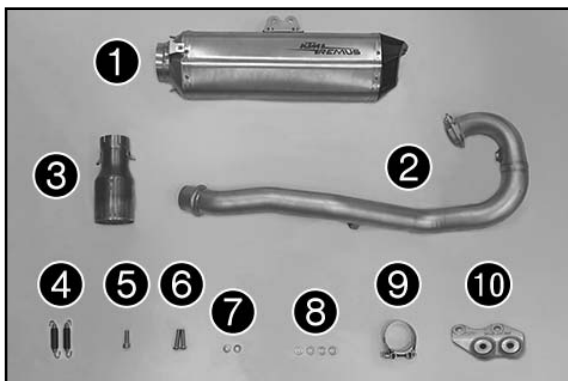

Volumen de suministro

- 1x silenciador ❶
- 1x colector ❷
- 1x catalizador ❸
- 2x muelles ❹
- 1x tornillo M8x30 ❺
- 2x tornillos M8x35 ❻
- 2x anillos elásticos M8 ❼
- 4x arandelas M8 ❽
- 1x abrazadera de tornillo ❾
- 1x soporte ❿
- 2x tuercas para chapa M8
- 1x arandela distanciadora

! AVISO

Esta instalación solo puede montarse y operarse en combinación con el mapping EFI especial de REMUS. El mapping debe instalarse sin falta en su concesionario antes de utilizarse por primera vez.



Advertencia

Peligro de quemaduras

El equipo de escape alcanza temperaturas muy elevadas durante el funcionamiento del vehículo.

- Dejar enfriar el equipo de escape. No tocar las piezas calientes.

Trabajos previos

- Quitar el asiento (véase el manual de instrucciones).
- Quitar el carenado lateral (véase el manual de instrucciones).

Desmontar el colector y el silenciador

- Retirar la cinta sujetacables ❶❶.
- Soltar y desenchufar el conector ❶❷ de la sonda lambda.
- Sacar el cable de la sonda lambda.
- Retirar los tornillos ❶❸.
- Retirar la chapa de protección térmica del sistema de escape.

- Retirar las tuercas ❶❹ del colector.

ADVERTENCIA

Tener cuidado de no perder el casquillo distanciador.

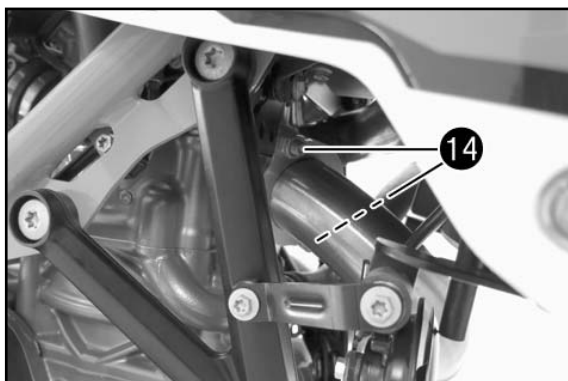
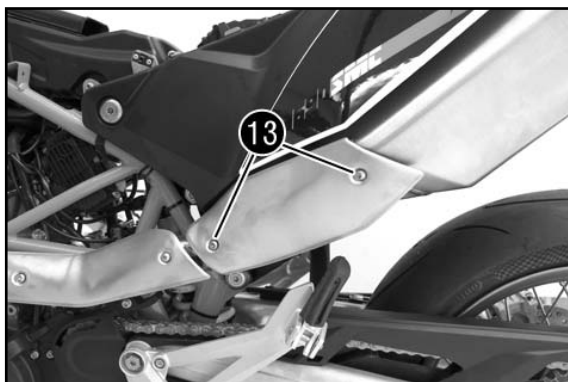
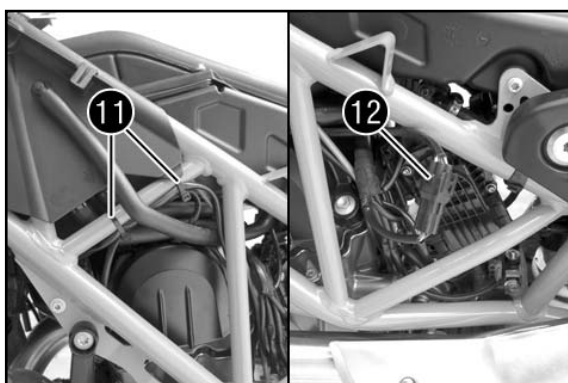

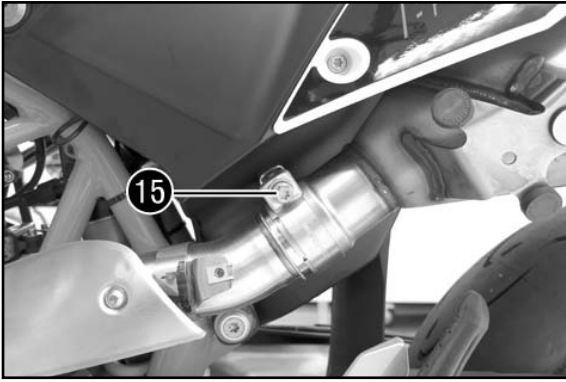

- Soltar la abrazadera de tornillo 15.

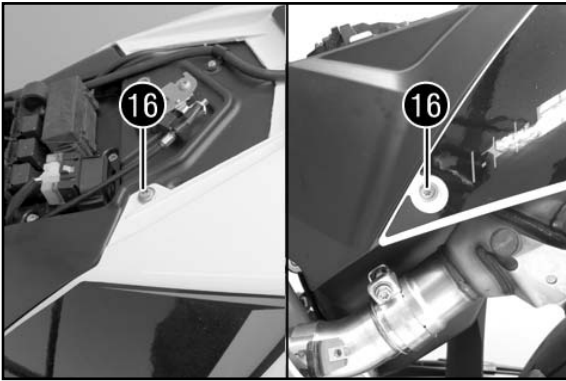

- Retirar los tornillos 16.
- Levantar el carenado trasero.

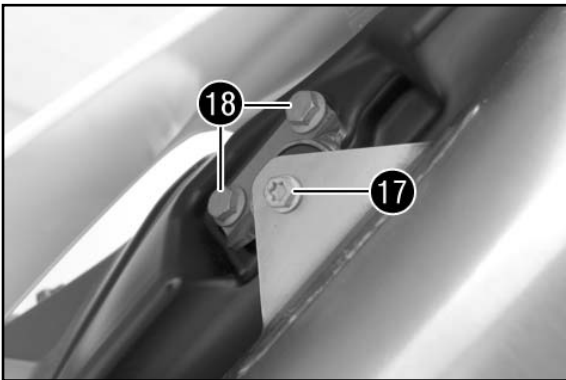

- Retirar el tornillo 17.
- Retirar el silenciador.
- Retirar los tornillos 18.
- Quitar el soporte.

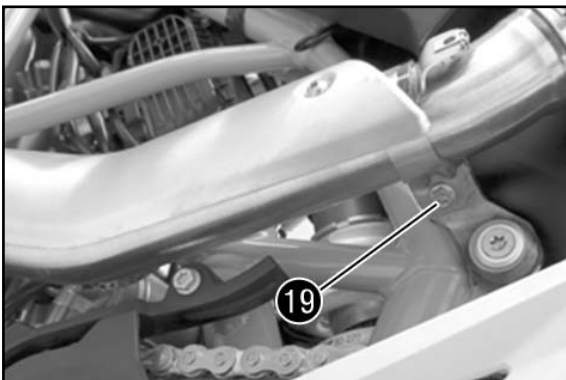

- Retirar el tornillo 19.
- Quitar el colector con la chapa de protección térmica del sistema de escape.

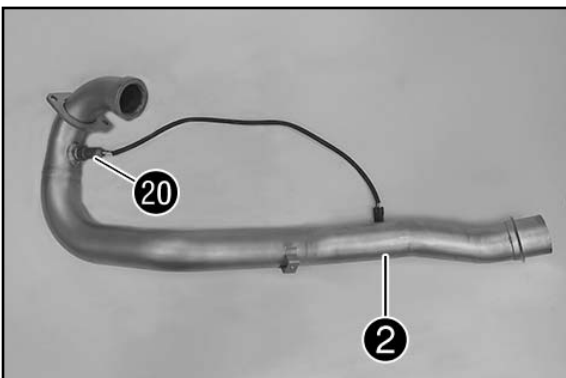

Montaje

- Retirar la sonda lambda 20 del colector original.
- Montar la sonda lambda 20 en el colector 2 (volumen de suministro) y apretarla a 25 Nm (engrasada con pasta de cobre).

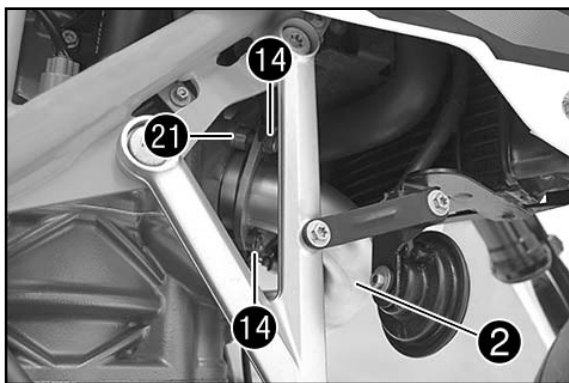

- Colocar el colector ②.
- Colocar el casquillo distanciador ②①.
- Montar las tuercas ①④ y apretarlas a 25 Nm (engrasadas con pasta de cobre).

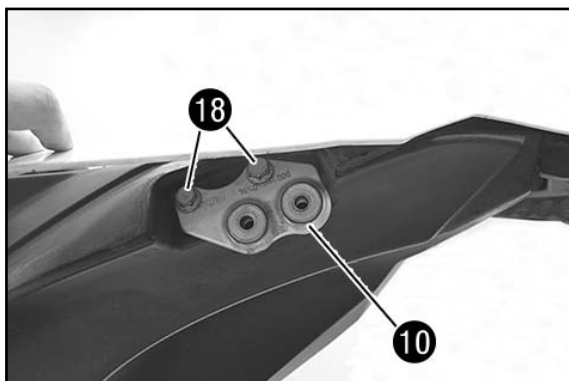

- Colocar el soporte ①⑩ (volumen de suministro).
- Montar los tornillos ①⑧ y apretarlos a 25 Nm.

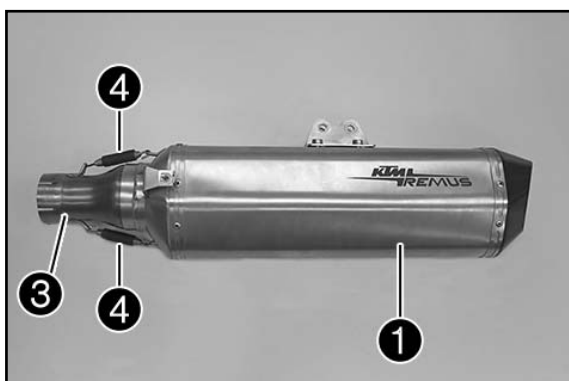

- Montar el catalizador ③ (volumen de suministro) en el silenciador ① (volumen de suministro).
- Montar los muelles ④ (volumen de suministro).

Gancho para muelles 503.05.017.000

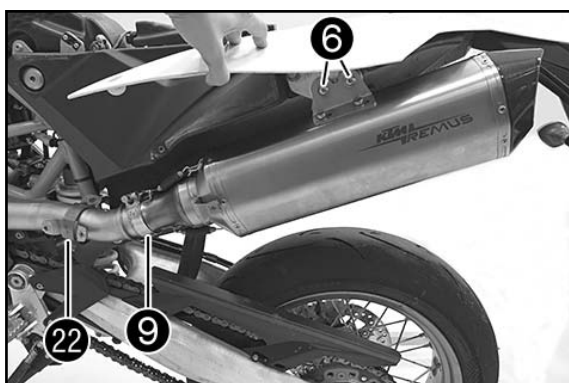

- Montar la abrazadera de tornillo ⑨ (volumen de suministro), pero no apretarla todavía.
- Montar el silenciador.
- Montar los tornillos ⑥ con los anillos elásticos ⑦ y las arandelas ⑧ (todo incluido en el volumen de suministro) y apretarlos a 25 Nm.

ADVERTENCIA

A continuación, apretar los 4 tornillos del soporte premontado en el silenciador también a 25 Nm.

- Colocar la abrazadera de tornillo ⑨ y apretarla a 12 Nm (engrasada con pasta de cobre).

- Montar la abrazadera de sujeción original ②② en el colector.

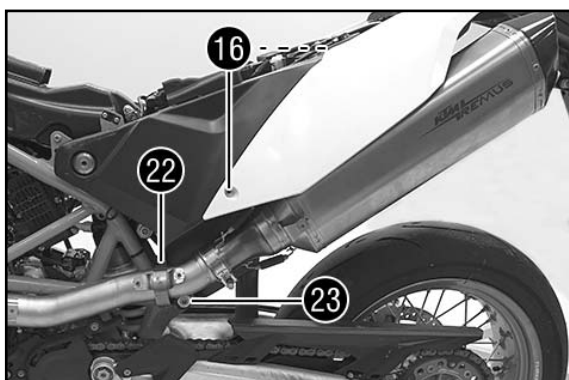

- Posicionar el carenado trasero.
- Montar los tornillos ①⑥ y apretarlos a 5 Nm.
- Montar la abrazadera de sujeción ②② con el tornillo ⑤, la arandela ③ y la arandela distanciadora (todo incluido en el volumen de suministro) y apretarla a 12 Nm (engrasada con pasta de cobre).

ADVERTENCIA

Para facilitar el montaje de la abrazadera de sujeción, retirar el tornillo ②③.

Par de apriete del tornillo del depósito de combustible inferior:
25 Nm (Loctite 243)

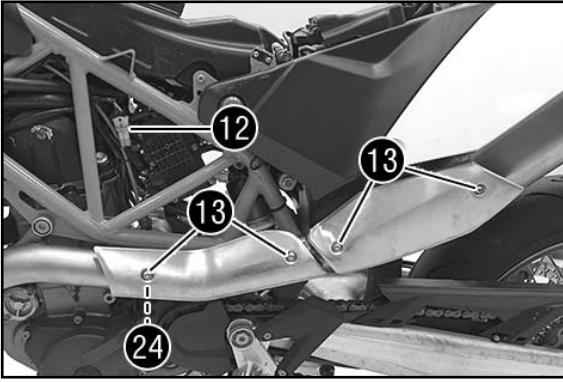

- Colocar la chapa de protección térmica del sistema de escape original.
- Montar los tornillos 13 y apretarlos a 8 Nm (Loctite 243).

ADVERTENCIA

Utilizar la tuerca para chapa 24 del volumen de suministro.

- Enchufar el conector 12 de la sonda lambda. Tender el cable sin tensiones y asegurarlo con cinta sujetacables.



Trabajos posteriores

- Montar el carenado lateral (véase el manual de instrucciones).
- Montar el asiento (véase el manual de instrucciones).

! AVISO

La primera vez que se utilice el silenciador, hay que mantener las revoluciones del motor a un régimen bajo durante aproximadamente 5 minutos para que el silenciador se caliente de forma uniforme. Esta es la única forma de que el material insonorizante alcance un rendimiento óptimo y se cumplan los niveles acústicos prescritos.